



Quick Installation Guide

ASW015K-TH/ASW020K-TH/ASW025K-TH
ASW29.9K-TH/ASW030K-TH



Android



iOS

1 General Information

This quick installation guide should be read together with the user manual. In case of doubt and uncertainties, the content in the user manual takes precedence over the content in this guide.

The contents of this guide may be updated or revised due to on-going product development and continuous improvement. The information in this guide is subject to change without notice. The latest version of this document and the user manual for installation, commissioning, configuration and decommissioning are to be found in PDF format at www.solplanet.net.

2 Safety

2.1 Intended use

The product is a transformerless hybrid inverter with four MPP trackers and one or two battery inputs that feeds the direct current of the PV array into the connected battery or converts it to grid-compliant three-phase current and then feeds it into onsite loads and the utility grid.

The product has a backup function that can continue to supply selected circuits with power from the battery or PV array in the event of a grid fault.

The product is intended for indoor and outdoor applications.

The product must only be connected with PV modules of protection class II (in accordance with IEC 61730, application class A).

The product is not equipped with an integrated transformer and therefore has no galvanic isolation. The product must not be operated with PV modules which require functional grounding of either the positive or negative PV conductors. This can cause the product to be irreparably damaged. The product may be operated with PV modules with frames that require protective earthing.

All components must remain within their permitted operating ranges and their installation requirements at all times.

Use the product only in accordance with the information provided in this guide, the user manual and with the locally applicable standards and directives. Any other application may cause personal injury or damage to property.

The product must only be operated in connection with an intrinsically safe lithium-ion battery approved by Solplanet. The entire battery voltage range must be completely within the permissible input voltage range of the product. The latest version of the Solplanet battery compatibility list can be found in PDF format at www.solplanet.net.

The product must only be used in countries for which it is approved by Solplanet and the grid operator.

The type label must be permanently attached to the product and must be in a legible condition.

This document does not replace any regional, state, provincial, federal or national laws, regulations or standards that apply to the installation, electrical safety and use of the product.

2.2 Important safety instructions

The product has been designed and tested strictly according to the international safety requirements. As with all electrical or electronical devices, there are residual risks despite careful construction. To prevent personal injury and property damage and to ensure long-term operation of the product, read this section carefully and observe all safety information at all times.

DANGER

Danger to life due to high voltages of the PV array or the battery!

The DC cables connected to the battery, or the PV array may be live. Touching the DC conductors or associated live components can cause lethal electric shocks. Disconnecting the DC connectors from the product under load, an electric arc may expose the user to electric shock and burns.

- Do not touch non-insulated cable ends.
- Do not touch the DC conductors without isolating all sources of energy.
- Do not touch any live components of the product.
- Do not open the product.
- Observe all safety information of the battery manufacturer.
- All work on the product must only be carried out by qualified personnel who have read and fully understood all safety information contained in this document and the user manual.

- Disconnect the product from all voltage and energy sources and ensure it cannot be reconnected before working on the product.
- Wear suitable personal protective equipment for all work on the product.

DANGER

Danger to life due to electric shock when touching live components in backup mode!

Regardless of the AC breaker and the PV switch of the inverter being switched off or disconnected, the parts of the system may still be live when the battery is providing power during backup mode.

- Do not open the product.
- Disconnect the product from all voltage and energy sources and ensure it can not be reconnected before working on the product.

DANGER

Danger to life due to fire or explosion when batteries are fully discharged!

A fire may occur due to incorrect charging of fully discharged batteries. This can result in death or serious injury.

- Ensure the battery is not fully discharged before commissioning the system.
- Contact the battery manufacturer before proceeding if the battery is fully discharged.

DANGER

Danger to life due to burns caused by electric arcs through short-circuit currents!

Short-circuit currents in the battery can cause heat accumulation and electric arcs if the battery is short circuited or wrongly installed. Heat accumulation and electric arcs may result in lethal injuries due to burns.

- Disconnect the battery from all voltages sources prior to performing any work on the battery.
- Only use properly insulated tools to prevent accidental electric shock or short circuits during installation.
- Observe all safety information of the battery manufacturer.

DANGER

Danger to life due to electric shock when touching live system components in case of a ground fault!

If a ground fault occurs, parts of the system may still be live. Touching live parts and cables may result in death or lethal injuries due to electric shock.

- Disconnect the product from voltage and energy sources and ensure it cannot be reconnected before working on the device.
- Handle PV module cables only by its insulation.
- Do not touch any parts of the substructure or frame of the PV array.
- Do not connect PV strings with ground faults to the product.

WARNING

Danger to life due to risk of fatal electric shock from measuring device damage caused by overvoltage!

Overvoltage can damage a measuring device and result in voltage being present in the enclosure of the measuring device. Touching the live enclosure of the measuring device results in death or lethal injuries due to electric shock.

- Only use measuring devices with a measurement span equal to or higher than the voltage rating of the product.

CAUTION

Risk of burns due to high temperature.

Some parts of the enclosure can become hot during operation.

- During operation, do not touch any parts other than the enclosure lid of the product.

CAUTION

Risk of injury due to weight of product.

Injuries may result if the product is incorrectly handled or dropped while being transported or mounted.

- Transport and lift the product carefully. Take the weight of the product into account.
- Wear suitable personal protective equipment for all work on the product.

2.3 Symbols on the label



Beware of a danger zone!

This symbol indicates that the product must be additionally grounded if additional grounding or equipotential bonding is required at the installation site.



Beware of high voltage and operating current!

The inverter operates at high voltage and current. Work on the inverter must only be carried out by skilled and authorized electricians.



Beware of hot surfaces!

The inverter can become hot during operation. Avoid contact during operation.



WEEE designation

Do not dispose of the product together with the household waste but in accordance with the disposal regulations for electronic waste applicable in the country of installation.



CE marking

The product complies with the requirements of the applicable EU directives.



Certification mark

The product has been tested by TÜV and received the quality certification mark.



RCM (Regulatory Compliance Mark)

The product complies with the requirements of the applicable Australian standards.

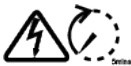

Capacitor discharge

Danger to life due to high voltages in the inverter. Do not touch live parts for 5 minutes after disconnection from the power sources.



Observe the documentation

Observe all documentation supplied with the product.

3 System Wiring Diagram

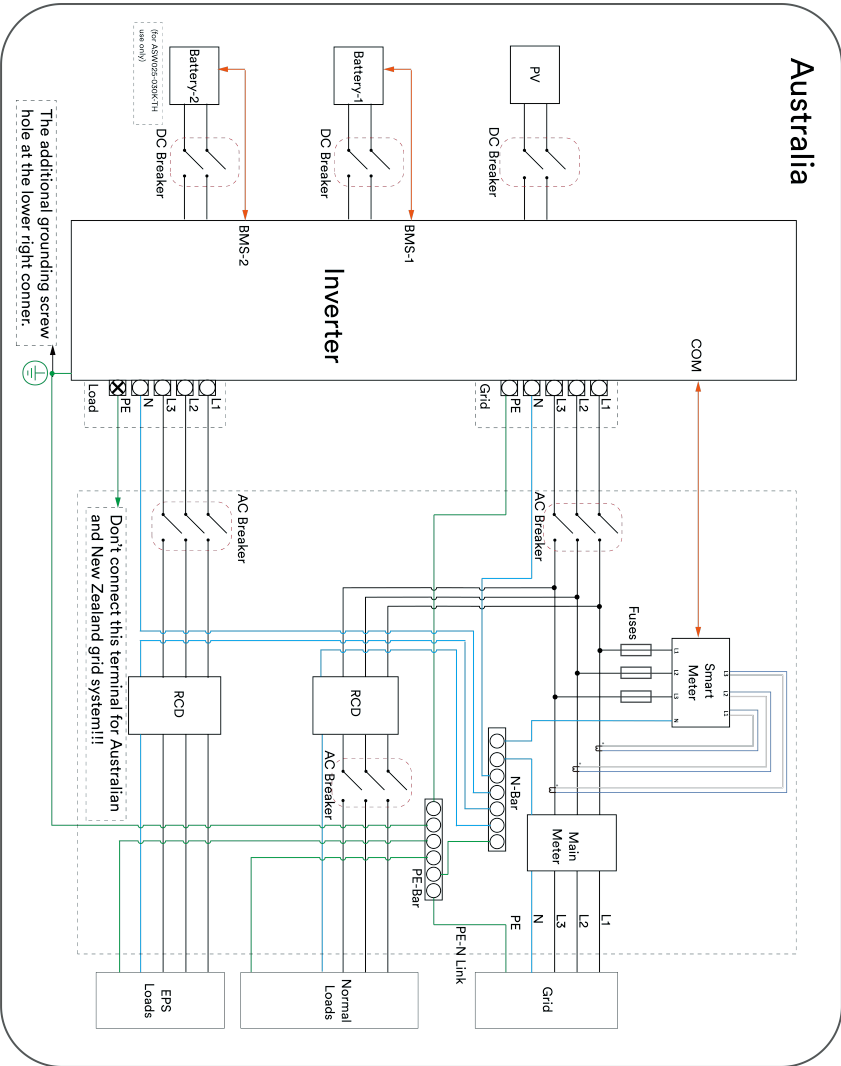

Europe

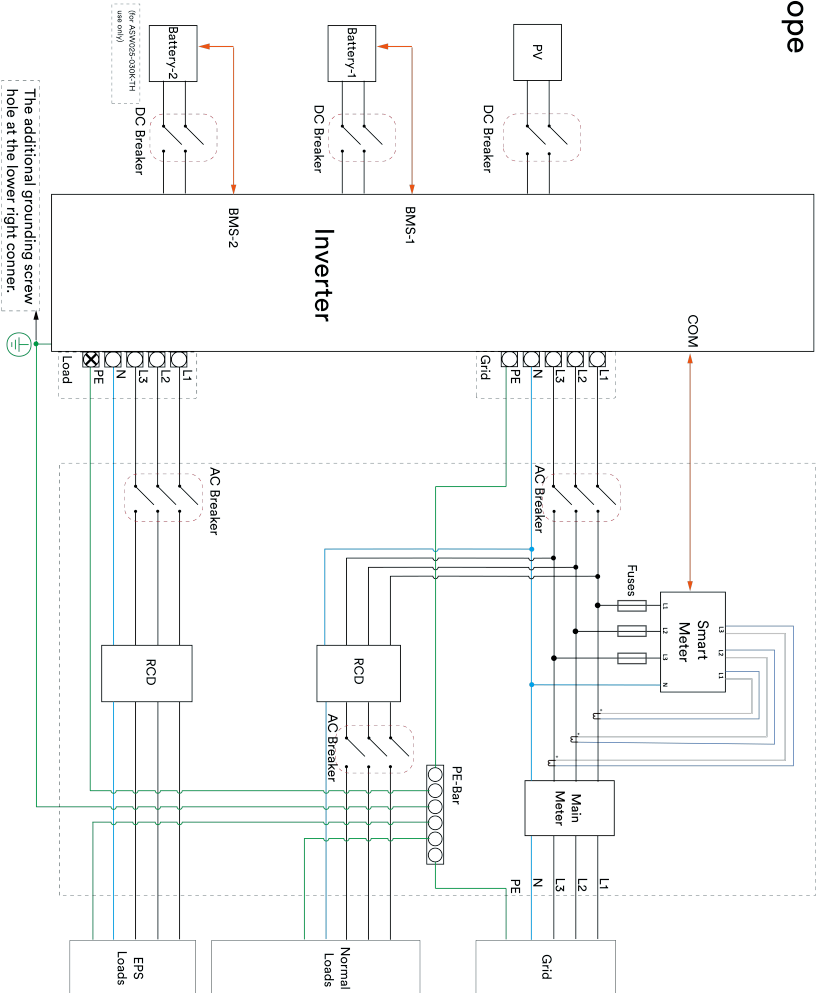

The wiring of a basic application as an example for grid connected systems without special requirements is shown below:

3.1 Wiring diagram for a single-unit system :

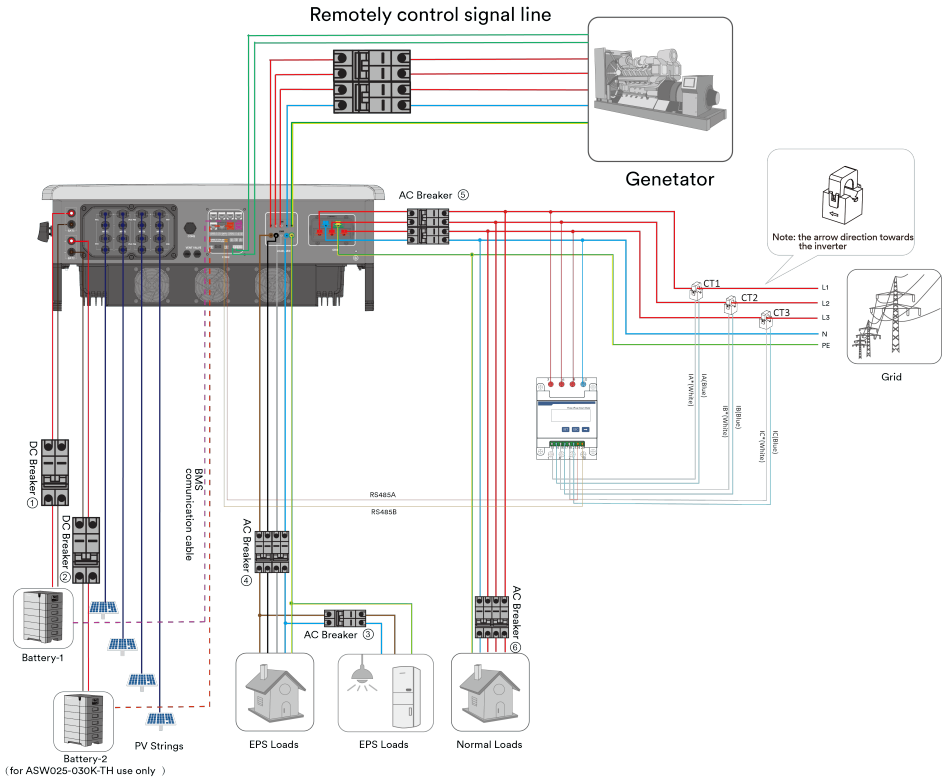

Note: 1. Enabling is required when using the generator; 2. The generator dry contact start control signal relay contact is 250V/1Amax.

Breaker No.	ASW015K-TH	ASW020K-TH	ASW025K-TH	ASW29.9K-TH	ASW030K-TH
1	63 A/1000 V DC Breaker		63 A/1000 V DC Breaker		
2	/	/			
3	63 A/400 V AC Breaker		100 A/400 V AC Breaker		
4	80 A/400 V AC Breaker				
5					
6	Dependent on the normal loads which should be checked by an installer				

3.2 Wiring diagram of grid-connected and parallel-operated system

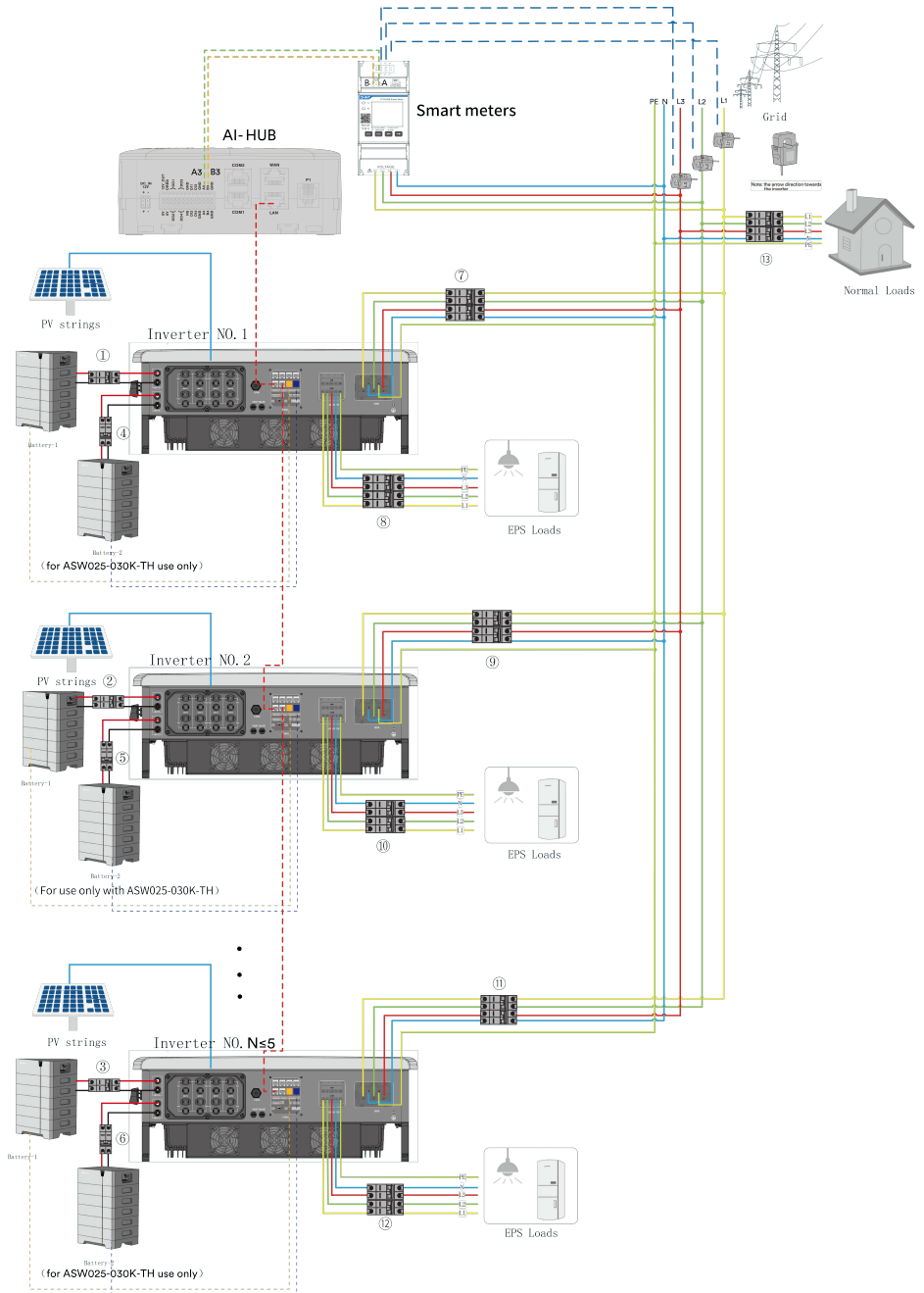

3.3 Wiring diagram of EPS parallel system

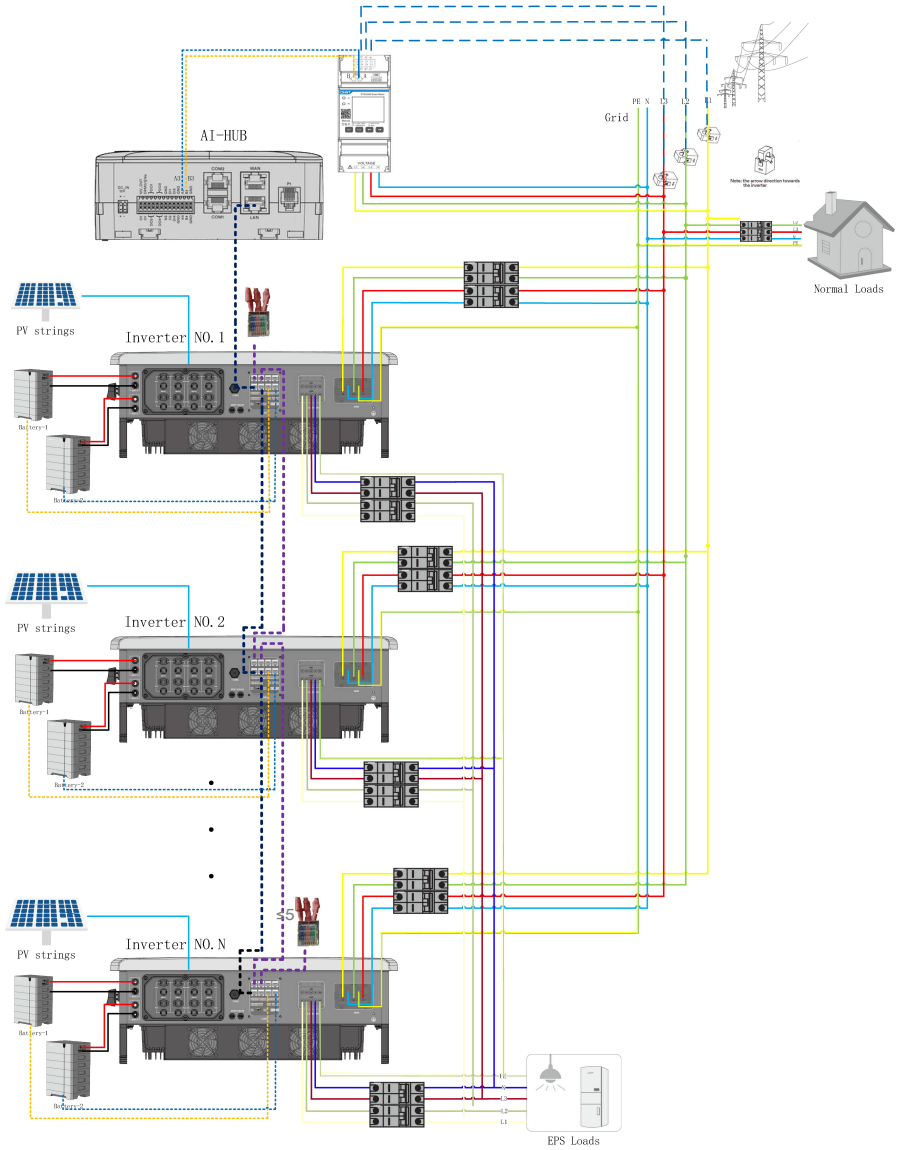

The terminating resistor is included in the AI-HUB packaging box.

4 EU Declaration of Conformity

Within the scope of the EU directives

- Radio Equipment Directive 2014/53/EU (L 153/62-106. May 22. 2014) (RED)
- Restriction of the use of certain hazardous substances 2011/65/EU (L 174/88, June 8, 2011) and 2015/863/EU (L 137/10, March 31,2015) (RoHS)



AISWEI Technology Co., Ltd. confirms herewith that the products described in this document are in compliance with the fundamental requirements and other relevant provisions of the above mentioned directives. The entire EU Declaration of Conformity can be found at www.solplanet.net.

5 Overview

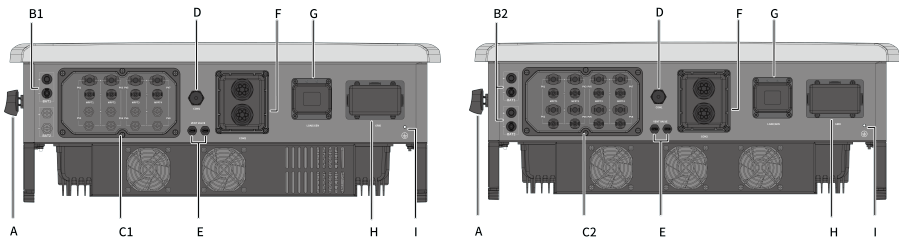

ASW015-020K-TH (left)

ASW025-030K-TH (right)

Object	Description
A	DC-Switch
B1/2	Battery Connector Ports
C1/2	PV Input
D	Ai-Dongle Port
E	Ventilation valve port
F	Communication Ports
G	Diesel Generator Connector Port (Reserved)
	EPS Load Connector Port
H	AC Connector Port
I	Additional Grounding Screw

6 Scope of Delivery

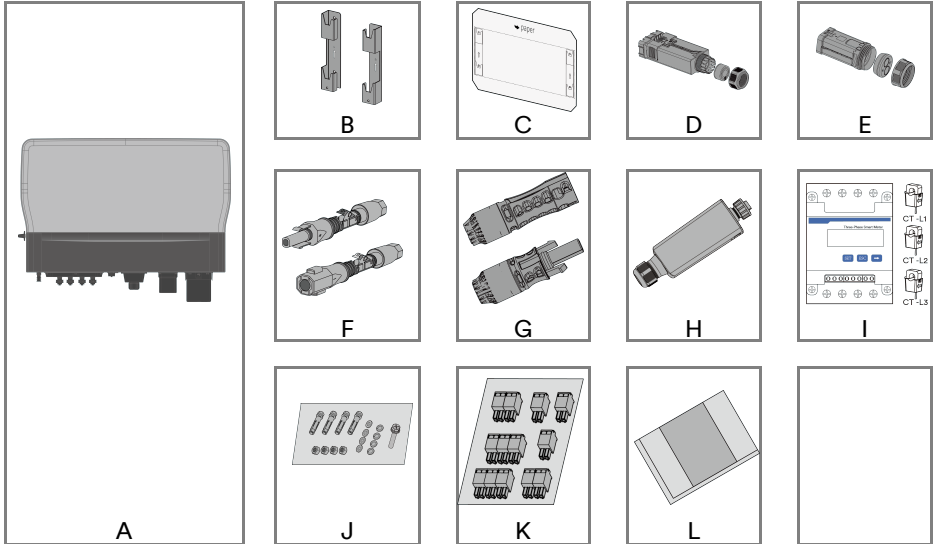

Object	Description	Quantity	
A	Inverter	1	
B	Mounting Bracket	1	
C	Mounting Bracket Template	1	
D	AC Connector	1	
E	Diesel Generator Connector (Reserved)	1	
	EPS Load Connector		
F	DC Connector(pair, positive & negative)	ASW015-020K-TH	4
		ASW025-030K-TH	8
G	Battery Connector(pair, positive & negative)	ASW015-020K-TH	1
		ASW025-030K-TH	2
H	Ai-Dongle	1	
I	Smart Meter (CTs included)	1	
J	Fastener Package	1	
K	Communication Terminal Package	1	
L	Document package	1	

7 Solplanet App

7.1 Brief introduction

The Solplanet App is an Android and iOS App which is used to set up and commission the inverter and connect it to the Solplanet cloud.

7.2 Download and install

Scan the following QR code which directs to the Google Playstore or Apple App Store, download and install the Solplanet App according to the prompt information.



8 Mounting Environment

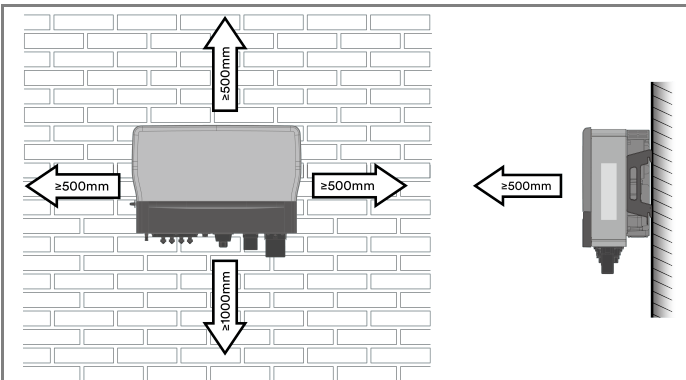
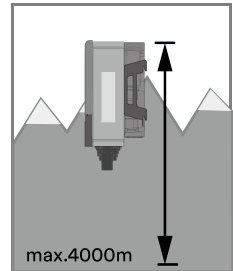
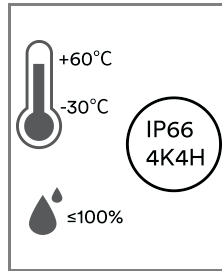
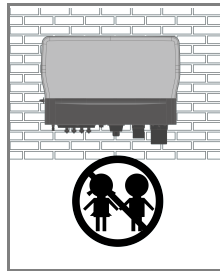
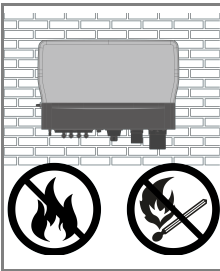
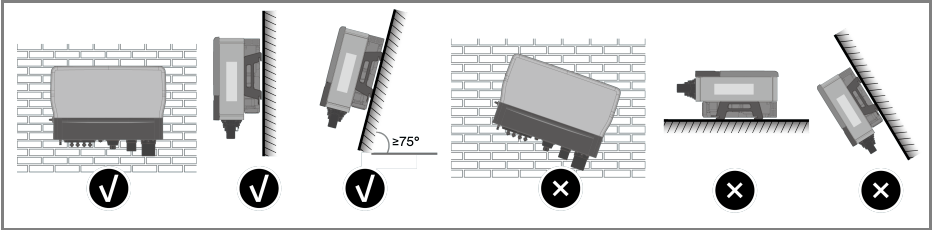
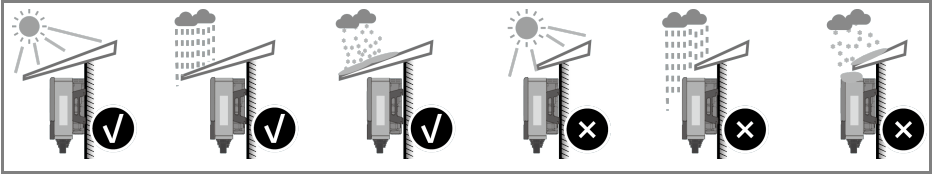

9 Dimensions

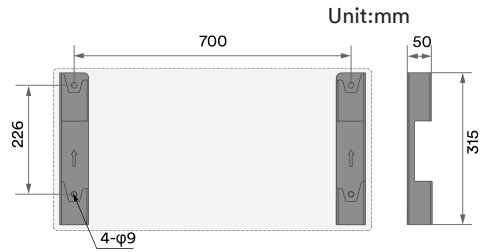
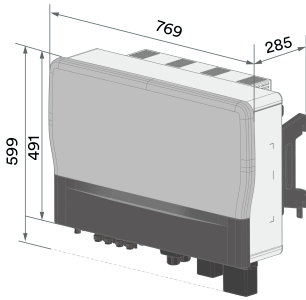

10 Mounting

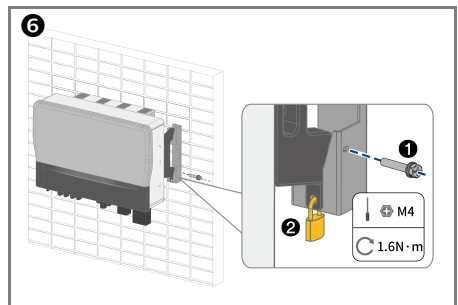
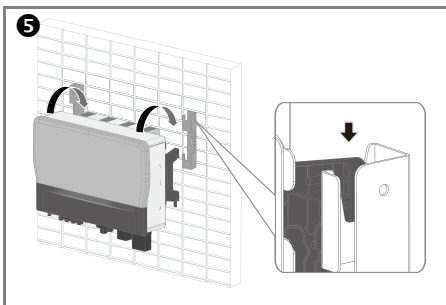
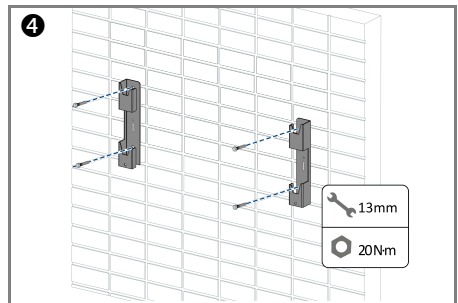
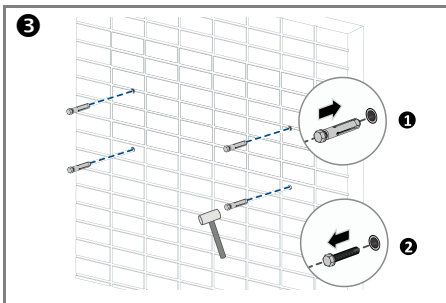
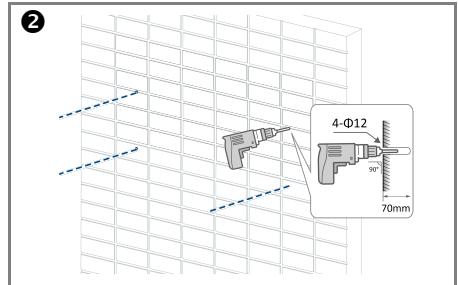
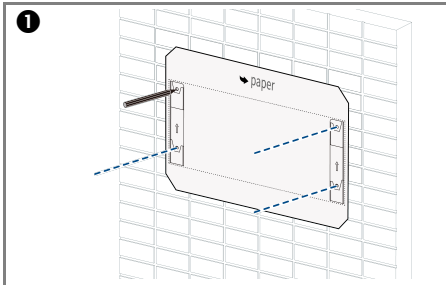

11 Secondary Protective Grounding

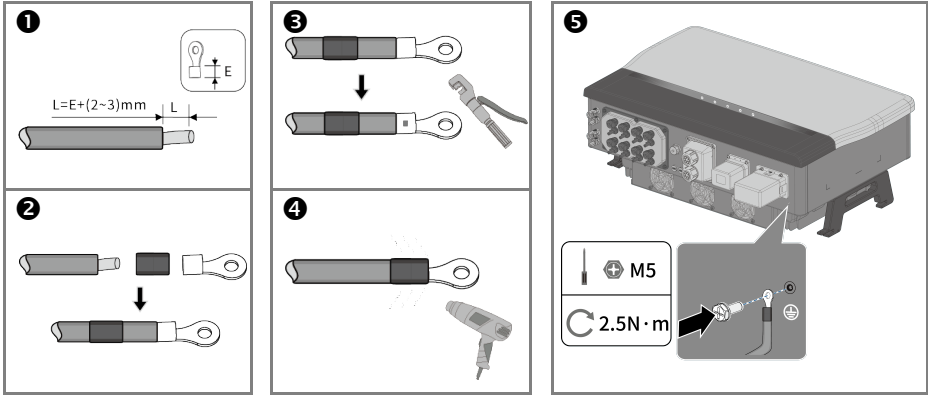

12 AC Connection

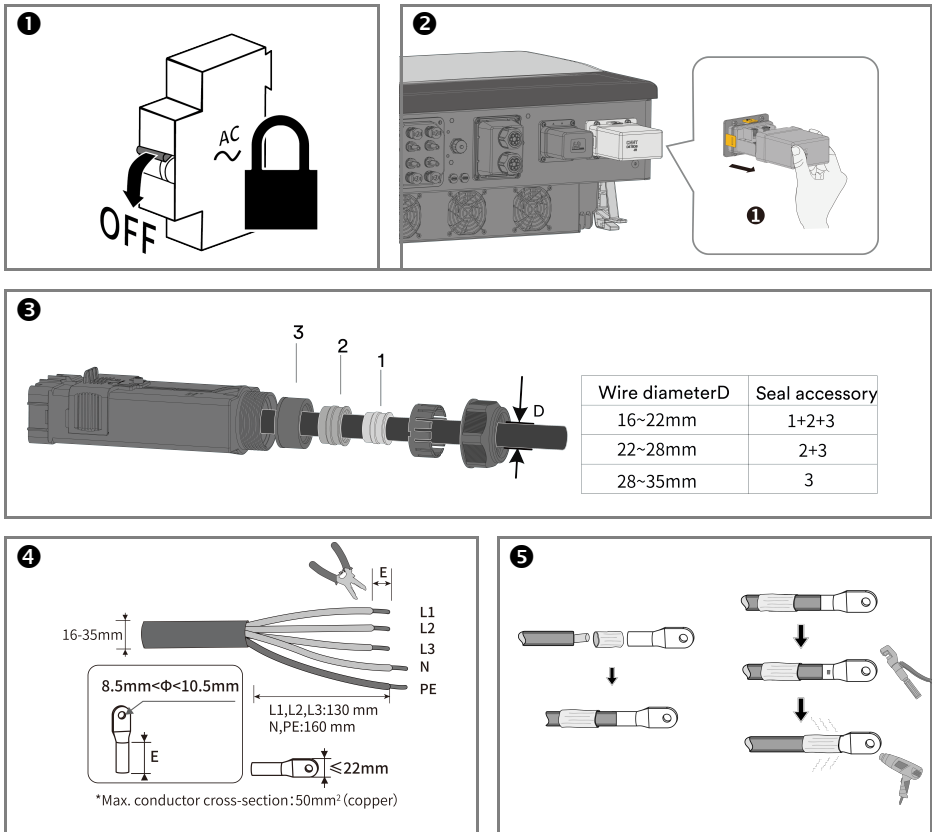

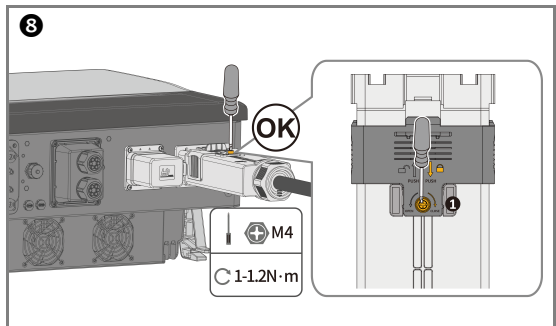
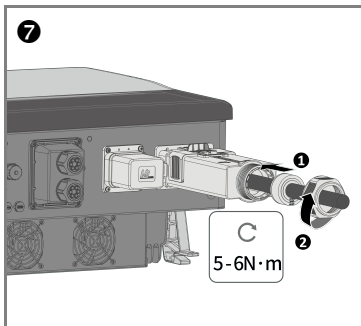
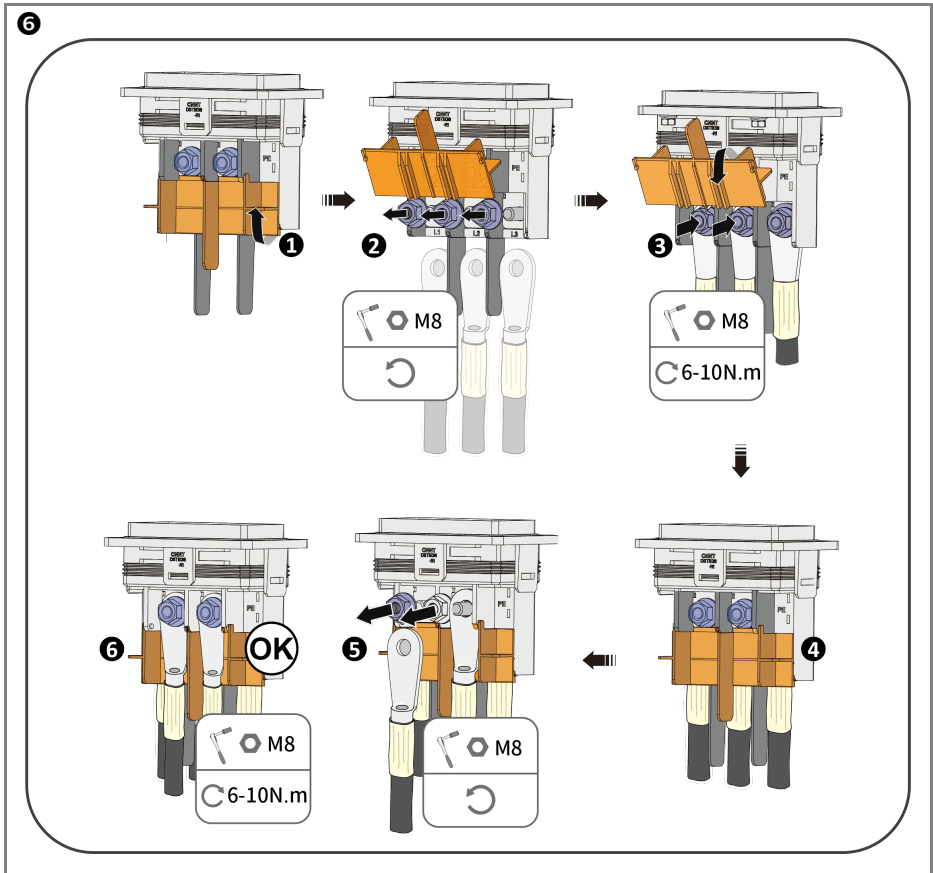



- The AC connector at customer side has to be tightened and sealed properly regardless if there is no grid connection.

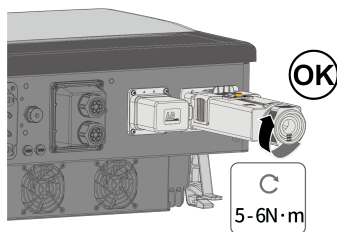

13 EPS Load / Diesel Generator Connection

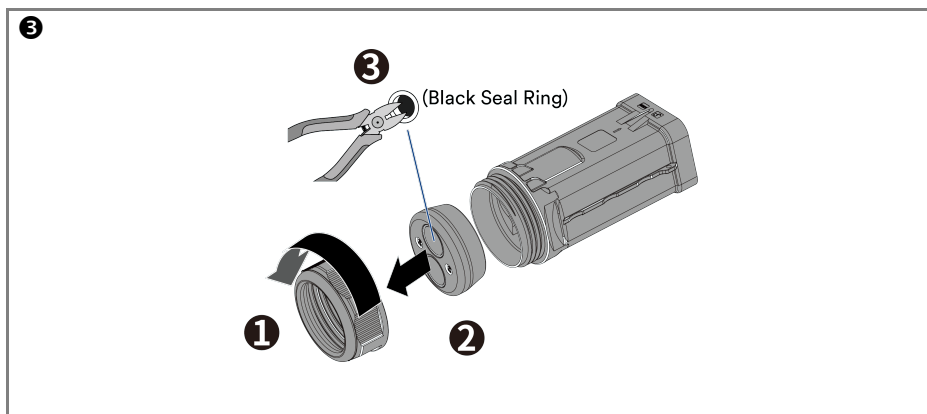
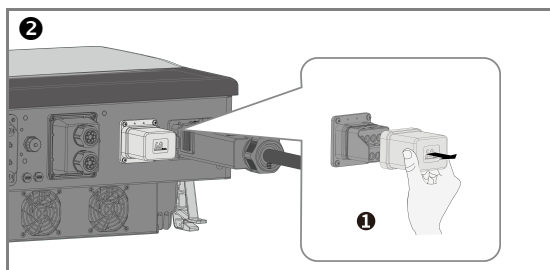
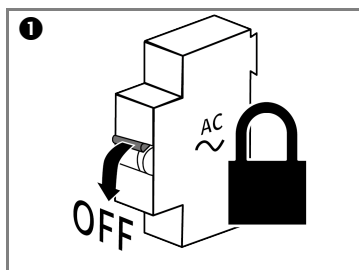

4

TYPE 1

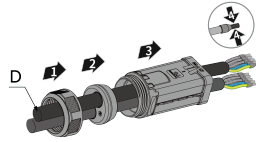

Seal accessory option(mm)						
D	12.3-14.8	14.8-17.3	17.3-19.8	19.8-22.3	22.3-24.8	24.8-27.3
	Black	Red	Orange	Blue	Light Gray	Dark Grey

5

TYPE 2

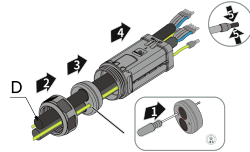
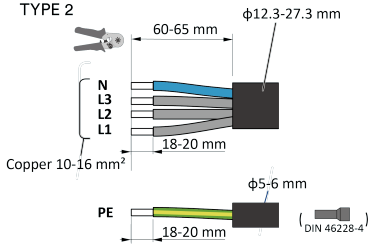

Seal accessory option(mm)						
D	12.3-14.8	14.8-17.3	17.3-19.8	19.8-22.3	22.3-24.8	24.8-27.3
	Black	Red	Orange	Blue	Light Gray	Dark Grey

6

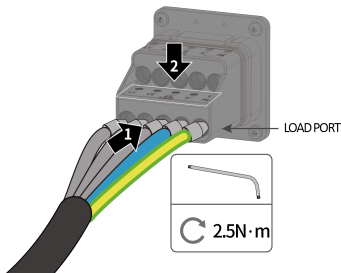

7

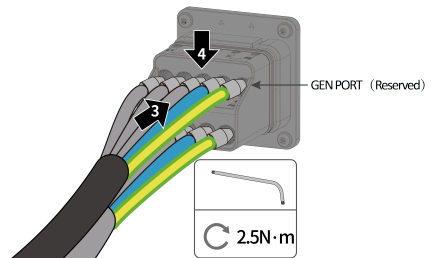

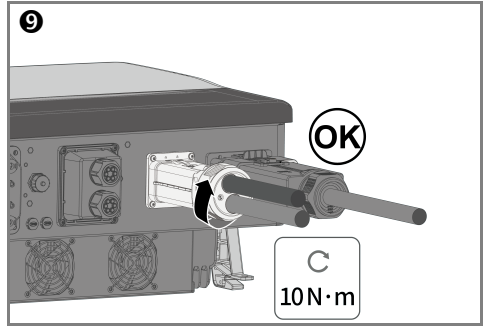
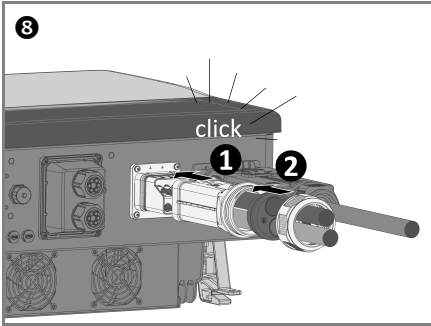

- The connector has to be tightened and sealed properly regardless if there is no load or diesel generator connected.

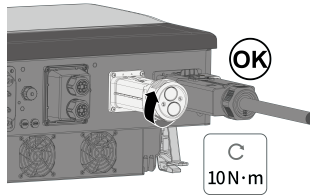

14 PV Connection

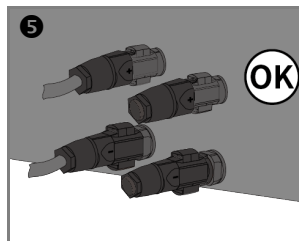
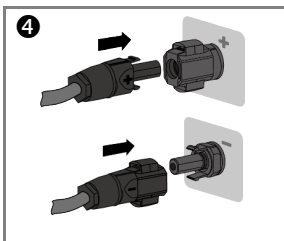
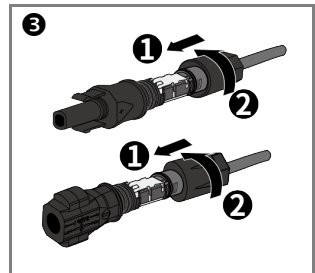
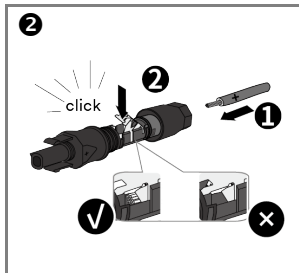
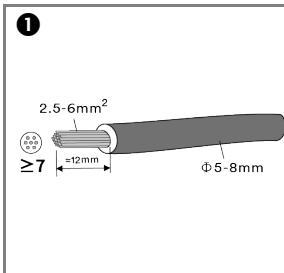

15 Battery Connection

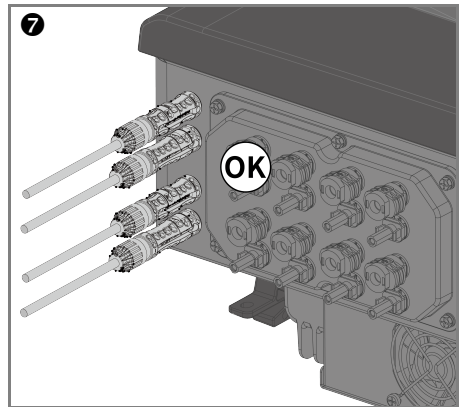
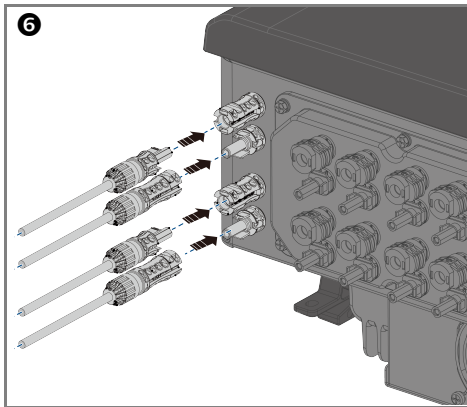
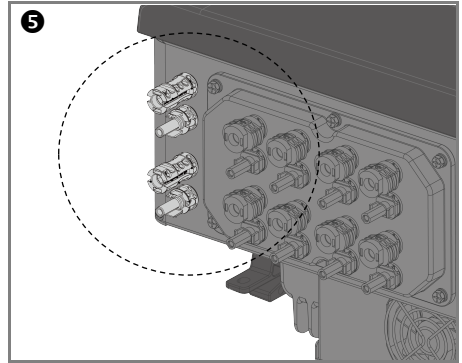
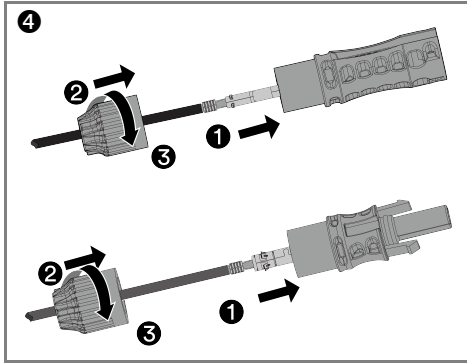
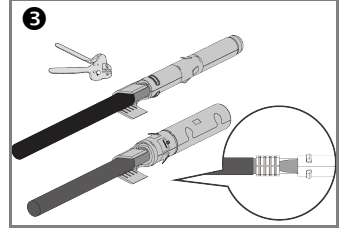
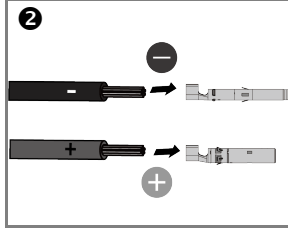
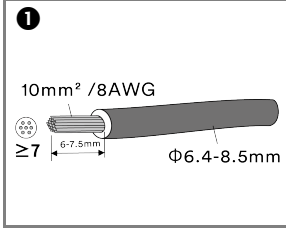

16 Communication Setup

16.1 Communication interfaces

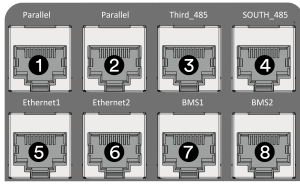

No.	PCB.No.	Description	Terminal	PIN definition							
				1	2	3	4	5	6	7	8
①/②	CN409/CN410	Parallel(Reserved)	COM1/2	RS485A _PARA	RS485B _PARA	X	RS485A _SYNC	RS485B _SYNC	X	CANBH _PARA	CANBL _PARA
③	CN407	Third_485	COM3	RS485A	RS485B	GND	X	X	X	X	X
④	CN408	SOUTH_485 (Reserved)	COM4	RS485A	RS485B	GND	X	X	X	X	X
⑤/⑥	CN421/CN422	Ethernet(Reserved)	COM5/6	TX+	TX-	RX+	X	X	RX-	X	GND
⑦	CN402	BMS1	COM7	X	GND	X	CANH	CANL	X	X	X
⑧	CN407	BMS2	COM8	X	GND	X	CANH	CANL	X	X	X

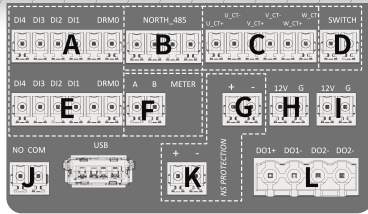
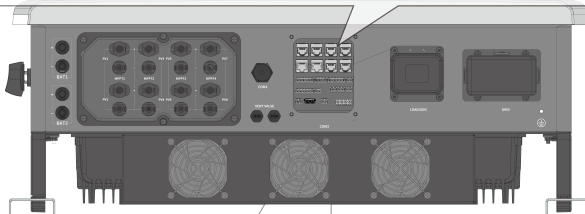

No.	PCB.No.	Description	Terminal	PIN definition					
				1	2	3	4	5	6
A/E	CN405/CN408	DI*4/DRMO	6pin	Ripple Control Receiver Device				DRMS Device	
				DI_4	DI_3	DI_2	DI_1	REF GEN/0	Com LOAD/0or GND
B	CN414	North_485 (Reserved)	4pin	RS485A	RS485B	GND	\	\	
C	CN406	CT (Reserved)	6pin	Current Transformer L1		Current Transformer L2		Current Transformer L3	
				Red	Black	Red	Black	Red	Black
D	CN411	ON/OFF	2pin	DI	GND	\	\	\	
F	CN413	Meter	2pin	RS485A	RS485B	\	\	\	
G/K	CN416/CN412	NS protection	2pin	NS-Protection (network and system protection) Device		\	\	\	
				Positive	Negative	\	\	\	
H/I	CN404/CN415	External output_12V	2pin	Selv_12V	GND	\	\	\	
J	CN420	AI-HUB_DI (Reserved)	2pin	DI	GND	\	\	\	
L	CN401	DO1/DO2 (Reserved)	4pin	Multifunctional Relay					
				DO1			DO2		
				A	B	A	B	\	\

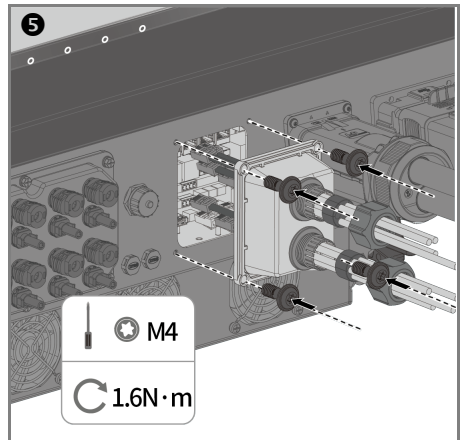
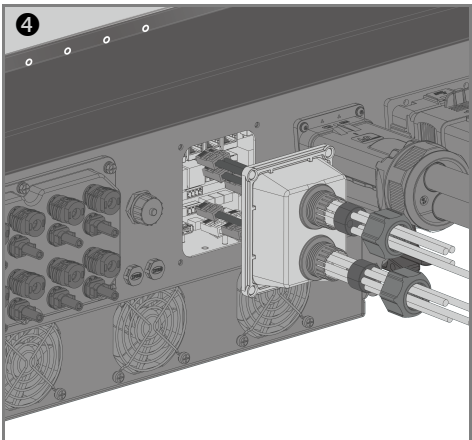
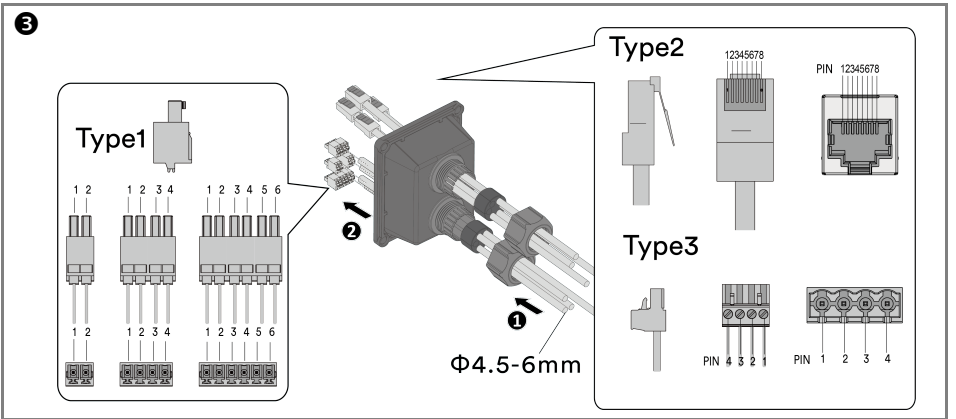
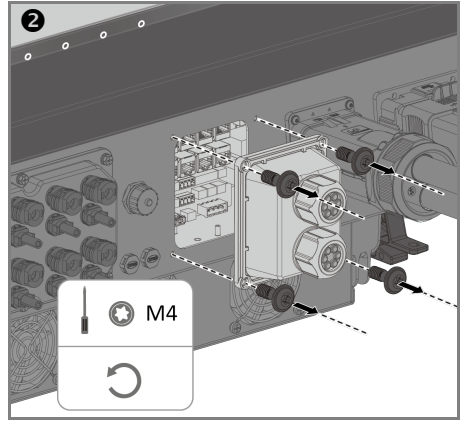
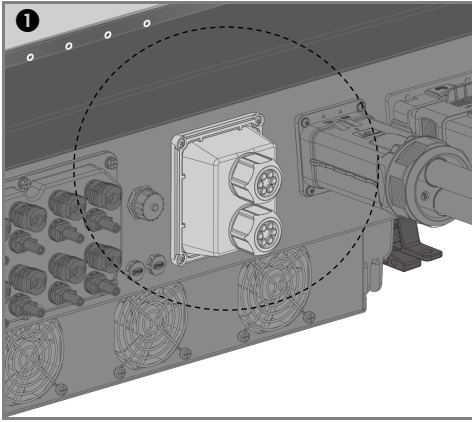

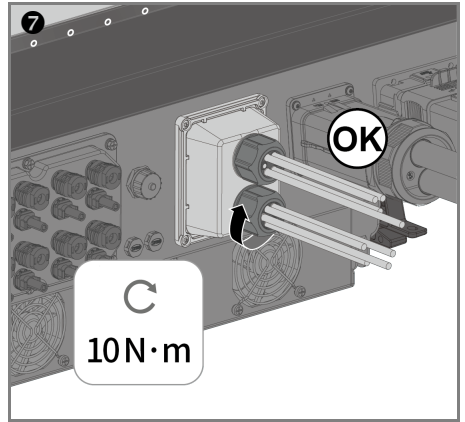
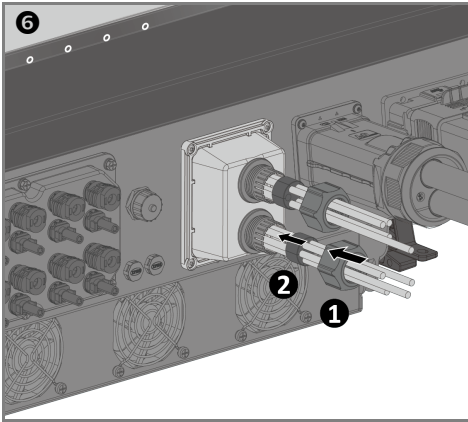

16.1.1 Ripple control connection

Position	PIN	Assignment
1		DI_4
2		DI_3
3		DI_2
4		DI_1
5		REF GEN/0
6		COM LOAD/0or GND

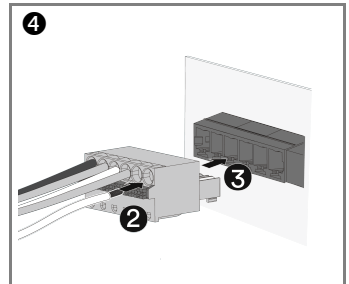
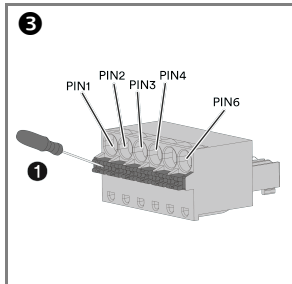
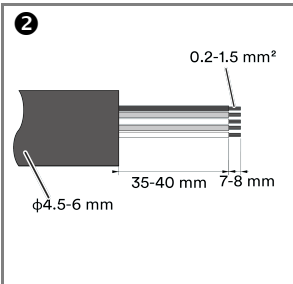

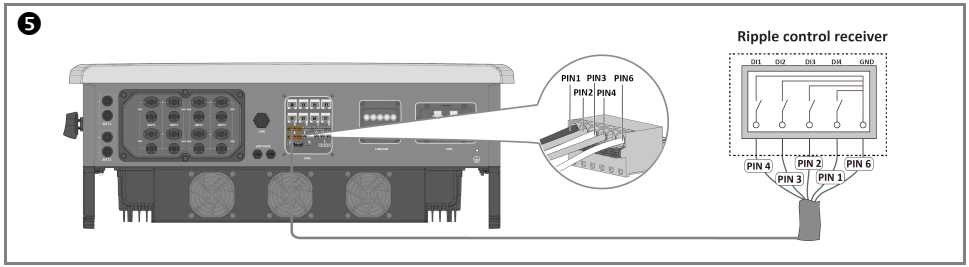

16.1.2 NS protection connection

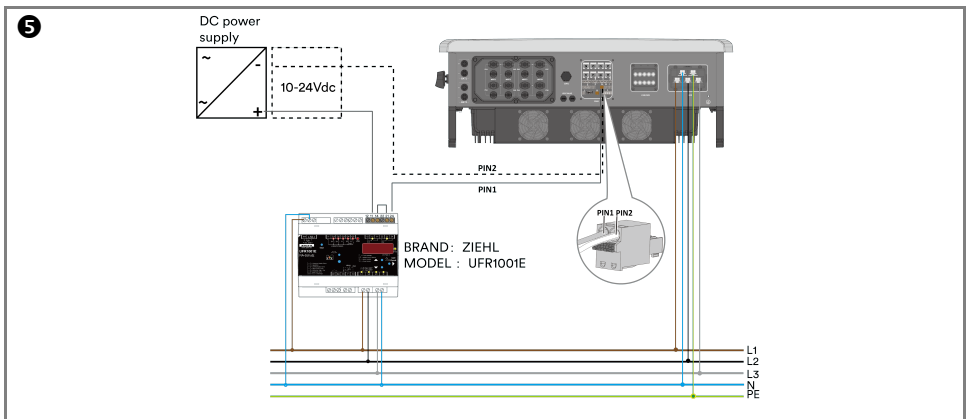
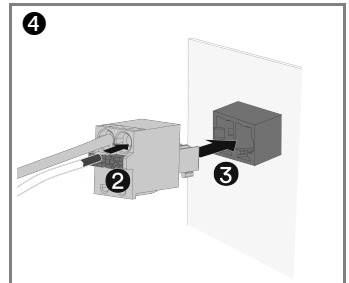
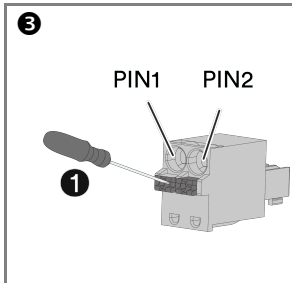
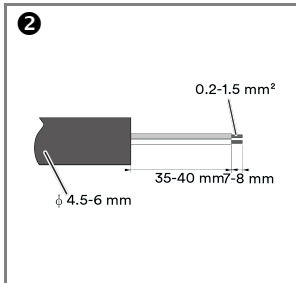
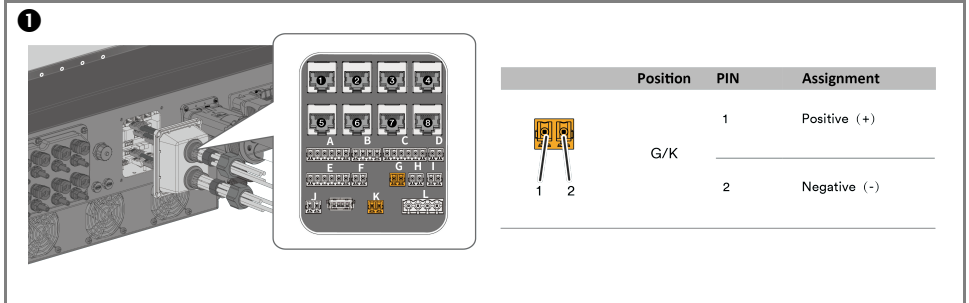



- Indicative only, please refer to the NS protection device user manual for correct wiring.

16.1.3 Smart meter connection

1

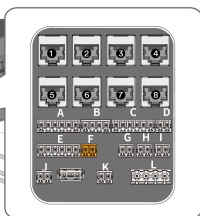
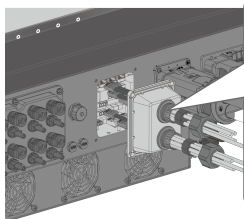

Position	PIN	Assignment
F	1	RS485A
	2	RS485B

2

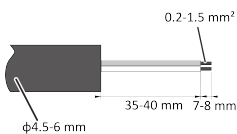

3

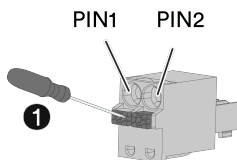

4

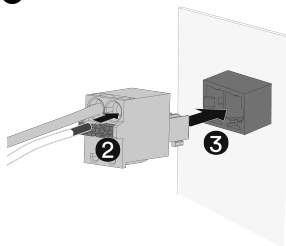

5

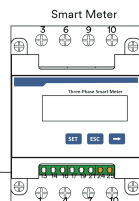
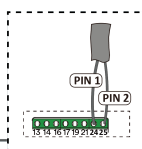
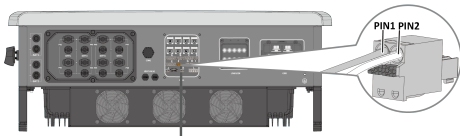

6

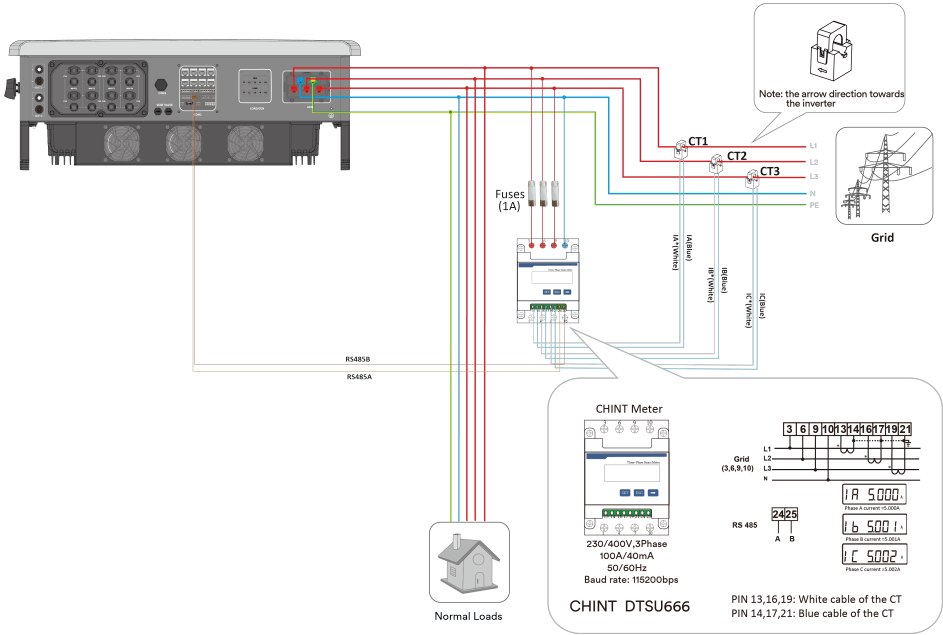

If using a dongle for wiring, refer to the diagram above.

If using an AI-HUB, connect the meter communication line to HUB A3/B3.

16.1.4 BMS Connection

1

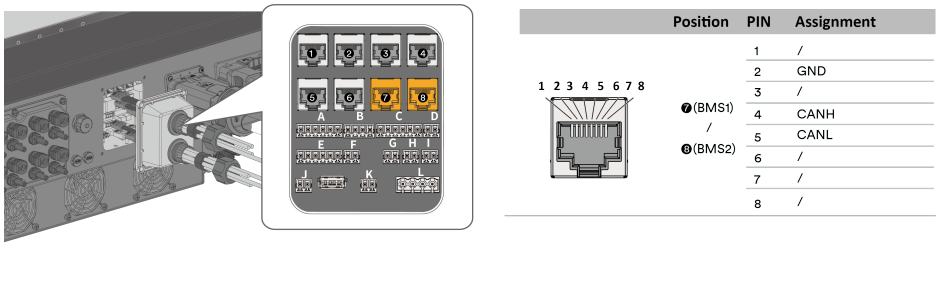

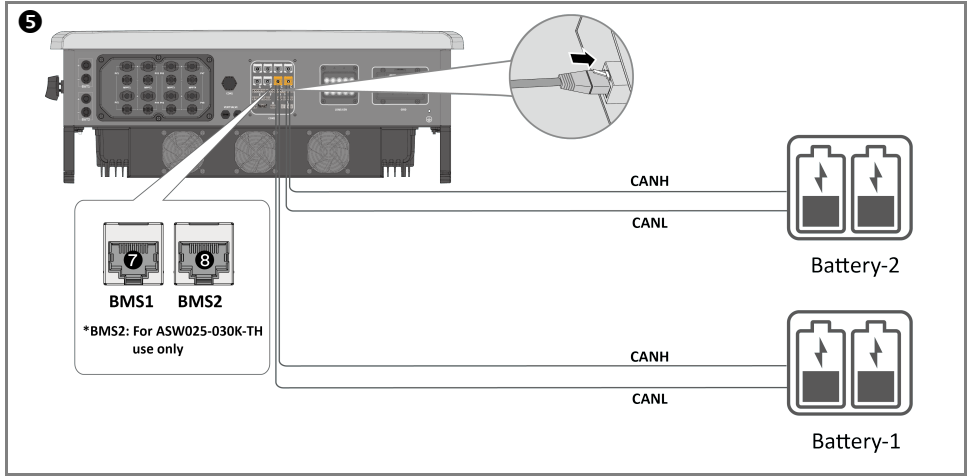

16.2 Ai-Dongle connection

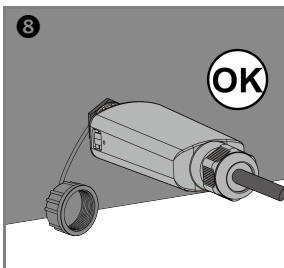
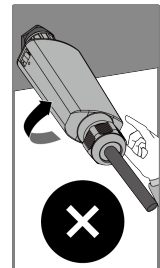
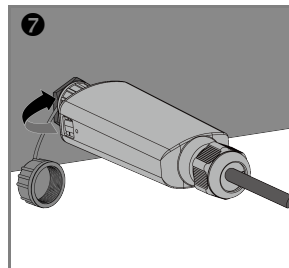
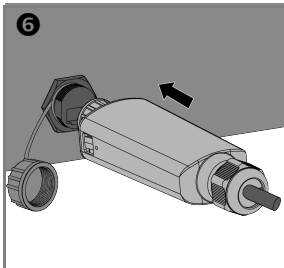
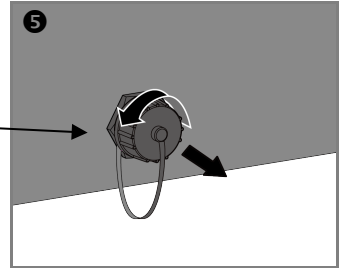
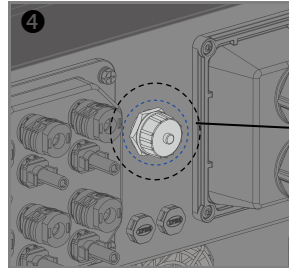
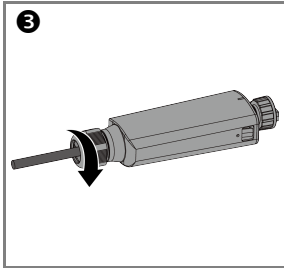
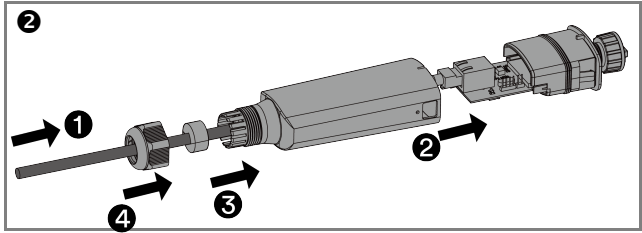
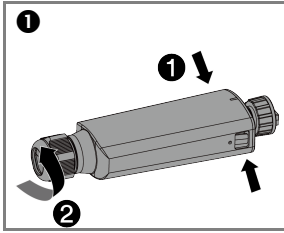

17 Contact

Please contact our Service Department if you have any technical questions about our products.

- The following information is needed to provide necessary assistance:
- Inverter model
- Inverter serial number
- Photovoltaic module model
- Photovoltaic modules quantity and string arrangement connected to each MPPT
- Fault code
- Installation location

EMEA

Service email: service.EMEA@solplanet.net

APAC

Service email: service.APAC@solplanet.net

LATAM

Service email: service.LATAM@solplanet.net

Aiswei Greater China

Service email: service.china@aiswei-tech.com

Hotline: +86 400 801 9996

Taiwan

Service email: service.taiwan@aiswei-tech.com

Hotline: +886 809089212

<https://solplanet.net/contact-us>



AISWEI Technology Co., Ltd.

Web: www.solplanet.net

Add.: No. 18, Alley 600, Nanchezhan Road, Huangpu District,
Shanghai, China



PN: 540-300767-03