



ASW05kH /06kH /08kH /10kH /12kH -T2-DG
ASW08kH /10kH /12kH /15kH-T3-DG

Three phase hybrid inverter

User Manual

Contents

1	General information.....	4
1.1	About this document	4
1.2	Product validity.....	4
1.3	Target group.....	4
1.4	Symbols.....	5
2	Safety	6
2.1	Intended use.....	6
2.2	Important safety instructions	6
2.3	Symbols on the label.....	9
3	Unpacking and storage	10
3.1	Scope of delivery	10
3.2	Product storage	11
4	Inverter overview	12
4.1	Product description	12
4.2	Dimensions	13
4.3	LED indicator.....	13
4.4	Supported grid types	14
4.5	Interfaces and functions	14
4.6	Basic system solution.....	17
4.7	Energy Management.....	20
4.8	Parallel System.....	27
5	Mounting.....	34
5.1	Requirements for mounting	34
5.2	Taking out and moving the product	35
5.3	Mounting.....	35
6	Electrical connection	38
6.1	Connection Interface description.....	38
6.2	Connecting additional grounding.....	39
6.3	Grid cable connection.....	40
6.4	EPS Load cable connection.....	44
6.5	Generator cable connection.....	48
6.6	DC connection.....	51
6.7	Battery connection	58
6.8	Ai-Dongle connection	60
6.9	Communication equipment connection	62
7	Commissioning and operating	72
7.1	Inspection before commissioning	72
7.2	Commissioning procedure.....	72
8	Solplanet APP.....	73

8.1	Brief introduction.....	73
8.2	Download and install.....	73
8.3	Create an account	73
8.4	Create a plant.....	74
8.5	Setting parameters	81
8.6	Parallel parameter setting and using	100
8.7	Activated Arc-fault Circuit Interrupter (AFCI).....	103
8.8	Digital output and Heat pump settings.....	105
8.9	AC-couple	107
9	Decommissioning the product	110
9.1	Disconnecting the inverter from voltage sources	110
9.2	Dismantling the inverter.....	112
10	Technical data	113
10.1	ASW05 kH/06kH/08kH/10kH/12kH-T2-DG	113
10.2	ASW08kH/10kH/12kH/15kH-T3-DG.....	115
10.3	General data	116
10.4	Protective device	117
11	Troubleshooting.....	118
12	Maintenance.....	120
12.1	Cleaning the contacts of the DC switch.....	120
12.2	Cleaning air inlet and outlet.....	120
12.3	Fan maintenance	120
13	Recycling and disposal.....	121
14	EU declaration of conformity	122
15	Service and warranty	122
16	Contact.....	123

1 General information

1.1 About this document

This document describes the mounting, installation, commissioning, configuration, operation, troubleshooting and decommissioning of the product as well as the operation of the product user interface.

You will find the latest version of this document and further information on the product in PDF format at www.solplanet.net.

It is recommended that this document is stored in an appropriate location and be available at all times.

1.2 Product validity

This document is valid for the following models:

- ASW05kH/06kH /08kH /10kH /12kH -T2-DG
- ASW08kH /10kH /12kH /15kH -T3-DG

1.3 Target group

This document is intended for qualified persons who must perform the tasks exactly as described in this user manual.

All installation work must be performed by appropriately trained and qualified persons.

Qualified persons must possess the following skills:

- Knowledge of how an inverter works and is operated.
- Knowledge of how batteries work and are operated.
- Training in how to deal with the dangers and risks associated with installing, repairing and using electrical devices, batteries and installations.
- Training in the installation and commissioning of electrical devices.
- Knowledge of all applicable laws, standards and directives.
- Knowledge of and compliance with this document and all safety information.

1.4 Symbols

DANGER

Indicates a hazardous situation which, if not avoided, will result in death or serious injury.

WARNING

Indicates a hazardous situation which, if not avoided, could result in death or serious injury.

CAUTION

Indicates a hazardous situation which, if not avoided, could result in minor or moderate injury.

NOTICE

Indicates a situation which, if not avoided, can result in property damage.



Information that is important for a specific topic or goal, however not related to safety.

2 Safety

2.1 Intended use

The product is a transformerless hybrid inverter with 2 or 3 MPP trackers and a battery connection that feeds the direct current of the PV array into the connected battery or converts it to grid-compliant three-phase current and then feeds it into the utility grid. The product also can convert the DC current supplied by the battery into grid-compliant three-phase current. A diesel generator interface is included to charge batteries and to supply the load. The product supports bi-directional AC power flow which allows the batteries to be charged by grid supplied AC current.

- The product has a backup function that can continue to supply selected circuits with power from the battery or PV system in the event of a grid fault.
- The product also can convert the direct current supplied by the battery into grid-compliant three phase current.
- The product is intended for indoor and outdoor applications.
- The product must only be connected with PV modules of protection class II (in accordance with IEC 61730, application class A).
- The product is not equipped with an integrated transformer and therefore has no galvanic isolation. The product must not be operated with PV modules which require functional grounding of either the positive or negative PV conductors. This can cause the product to be irreparably damaged. The product may be operated with PV modules with frames that require protective earthing.
- All components must remain within their permitted operating ranges and their installation requirements at all times.
- Use the product only in accordance with the information provided in the user manual and with the locally applicable standards and directives. Any other application may cause personal injury or damage to property.
- The product must only be operated in connection with an intrinsically safe lithium-ion battery approved by Solplanet. The entire battery voltage range must be completely within the permissible input voltage range of the product.
- The product must only be used in countries for which it is approved by Solplanet and the grid operator.
- Knowledge of all applicable laws, standards and directives.
- Knowledge of and compliance with this document and all safety information.
- The type label must be permanently attached to the product and must be in a legible condition.
- This document does not replace any regional, state, provincial, federal or national laws, regulations or standards that apply to the installation, electrical safety and use of the product.

2.2 Important safety instructions

The product has been designed and tested strictly according to the international safety requirements. As with all electrical or electronical devices, there are residual risks despite careful construction. To prevent personal injury and property damage and to ensure long-term operation of the product, read this section carefully and observe all safety information at all times.



Danger to life due to high voltages of the PV array or the battery!

The DC cables connected to the battery or the PV array may be live. Touching the DC conductors or the live components can cause lethal electric shocks. If you disconnect the DC connectors from the product under load, an electric arc may occur

leading to electric shock and burns.

- Do not touch non-insulated cable ends.
- Do not touch the DC conductors.
- Do not touch any live components of the product.
- Do not open the product.
- Observe all safety information provided by the battery manufacturer.
- All work on the product must only be carried out by qualified personnel who have read and fully understood all safety information contained in this document and the user manual.
- Disconnect the product from all voltage and energy sources and ensure it cannot be reconnected before working on the product.
- Wear suitable personal protective equipment for all work on the product.

DANGER

Danger to life due to electric shock when touching live components in backup mode!

Despite the AC breaker and the PV switch of the inverter being disconnected, parts of the system may still be live when the battery is switched on due to backup mode.

- Do not open the product.
- Disconnect the product from all voltage and energy sources and ensure it can not be reconnected before working on the product.

DANGER

Danger to life due to fire or explosion when batteries are fully discharged!

Danger to life due to fire or explosion when batteries are fully discharged.

- Ensure that the battery is not fully discharged before commissioning the system.
- Contact the battery manufacturer for further information if the battery is fully discharged.

DANGER

Danger to life due to burns caused by electric arcs through short-circuit currents!

Short-circuit currents in the battery can cause heat accumulation and electric arcs if the battery is short circuited or incorrectly installed. Heat accumulation and electric arcs may result in lethal injuries due to burns.

- Disconnect the battery from all voltages sources prior to performing any work on the battery.
- Only use properly insulated tools to prevent accidental electric shock or short circuits during installation.
- Observe all safety information of the battery manufacturer.

DANGER

Danger to life due to electric shock when touching live system components in case of a ground fault!

If a ground fault occurs, parts of the system may still be live. Touching live parts and cables may result in death or lethal injuries due to electric shock.

- Disconnect the product from voltage and energy sources and ensure it cannot be reconnected before working on the device.
- Only touch the cables of the PV modules on their insulation.
- Do not touch any parts of the substructure or frame of the PV array.
- Do not connect PV strings with ground faults to the product.

WARNING

Danger to life due to electric shock from destruction of the measuring device due to overvoltage !

Overvoltage can damage a measuring device and result in voltage being present in the enclosure of the measuring device. Touching the live enclosure of the measuring device results in death or lethal injuries due to electric shock.

- Only use measuring devices with a measurement span higher than the DC input voltage range

CAUTION

Risk of burns due to high temperature!

Some parts of the enclosure can become hot during operation.

- During operation, do not touch any parts other than the enclosure lid of the product.

CAUTION

Risk of injury due to weight of product!

Injuries may result if the product is lifted incorrectly or dropped while being transported or mounted.

- Transport and lift the product carefully. Take the weight of the product into account.
- Wear suitable personal protective equipment for all work on the product.

NOTICE

Damage to the inverter due to electrostatic discharge.

Internal components of the inverter can be irreparably damaged by electrostatic discharge.

- Ground yourself appropriately before touching any component.



The country grid code set must be set correctly.

If you select a country grid code set which is not valid for your country and purpose, it can cause a disturbance within the PV system and lead to problems with the grid operator. When selecting the country grid code set, you must always observe the locally applicable standards and directives as well as the properties of the PV system (e.g., PV system size, grid-connection point).

- If you are not sure which standards and directives are valid for your country or purpose, contact the grid operator.

2.3 Symbols on the label



Beware of a danger zone!

This symbol indicates that the product must be additionally grounded if additional grounding or equipotential bonding is required at the installation site.



Beware of high voltage and operating current!

The inverter operates at a high voltage and current. Work on the product must only be carried out by skilled and authorized personnel.



Beware of hot surfaces!

The inverter can get hot during operation. Avoid contact during operation.



WEEE Designation

Do not dispose of the product together with household waste. Dispose the product in accordance with local disposal regulations for electronic waste.



CE marking

The product complies with the requirements of the applicable EU directives.



Certification mark

The product has been tested by TUV and obtained the quality certification mark.



RCM Mark

The product complies with the requirements of the applicable Australian standards.



Capacitor discharge

Danger to life due to high voltages in the inverter. Do not touch live parts for at least 10 minutes after disconnection from the power sources.



Observe the documentation

Read and understand all documentation supplied with the product.

3 Unpacking and storage

3.1 Scope of delivery

Check the scope of delivery for completeness and any visible external damage. Contact your distributor if the scope of delivery is incomplete or damaged.

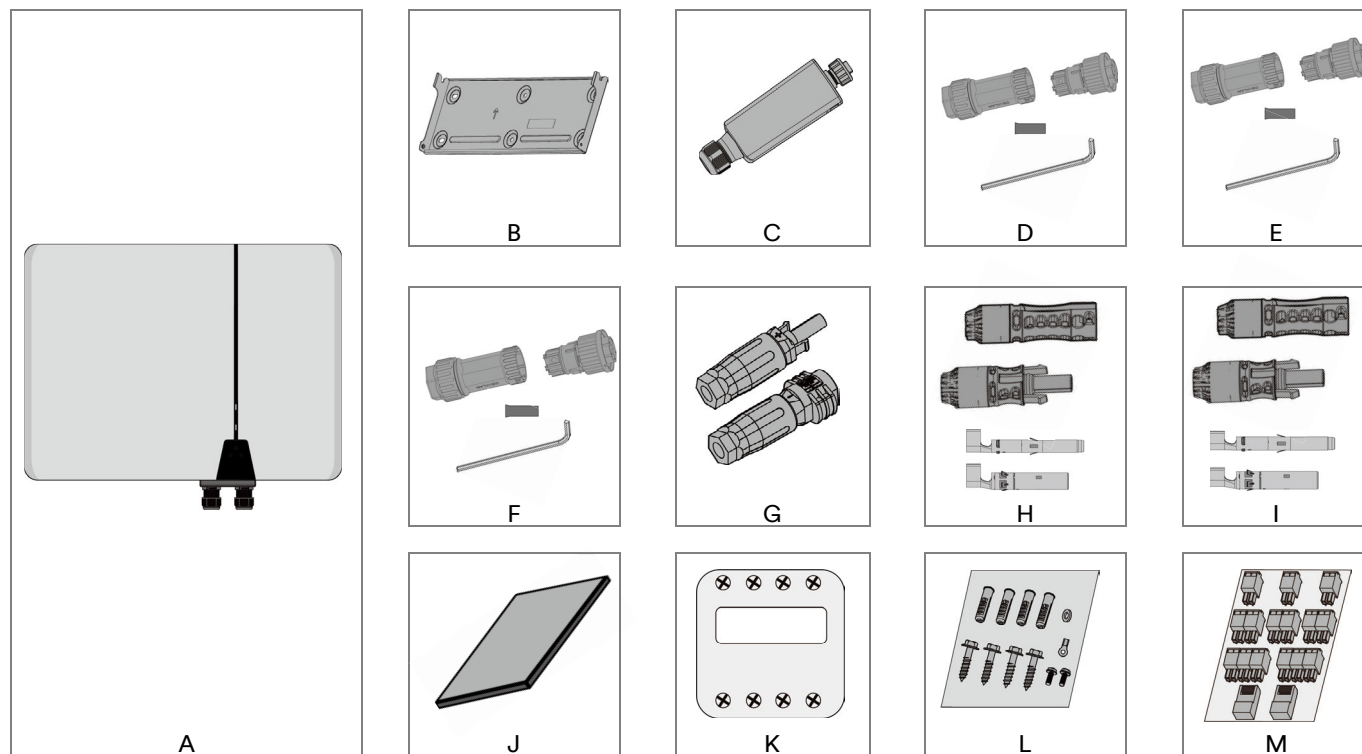

Object	Description	Type/Quantity		
A	Inverter	1		
B	Mounting bracket	1		
C	Ai-Dongle	1		
D	GRID connector (black)	1		
	Tubular terminal	5		
	Hex Key S=2.5	1		
E	EPS Load connector (blue)	1		
	Tubular terminal	5		
	Hex Key S=2.5	1		
F	Diesel generator connector (red)	1		
	Tubular terminal	5		
	Hex Key S=2.5	1		
G	DC connector	PV-C3F-S 2.5-6(+)-1386381	ASW05-12KH-T2-DG	2
		PV-C3M-S 2.5-6(-)-1386384	ASW08-15KH-T3-DG	3
H	Battery connector	Socket: PV-KBT4-EVO ST/6I		1
		Plug: PV-KST4-EVO ST/6I		1
	Crimp contact (6mm ²)	PV-BP4-EVO 2/6		1
		PV-SP4-EVO 2/6		1
I	Battery connector	Socket: PV-KBT4-EVO ST/10II		1

		Plug: PV-KST4-EVO ST/10II	1
	Crimp contact (10mm ²)	PV-BP4-EVO 2/10	1
		PV-SP4-EVO 2/10	1
J	Document	1	
K	Smart meter	1	
L	Fastener package	1	
M	Communication terminal package	1	

3.2 Product storage

Suitable storage is required if the inverter is not installed immediately:

- Store the inverter in the original packing case.
- The storage temperature must be between -30°C to +70°C, and the storage relative humidity must be between 0 and 100%, non-condensing.
- The packing with the inverter shall not be tilted or inverted.
- The product must be fully inspected and tested by professionals(Refer to section 1.3) before it can be put into operation, if it has been stored for half a year or more.

4 Inverter overview

4.1 Product description

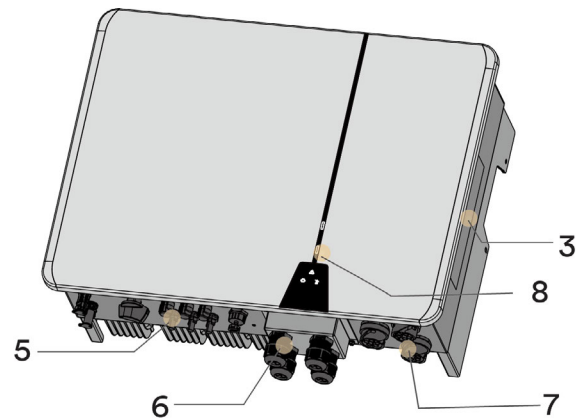
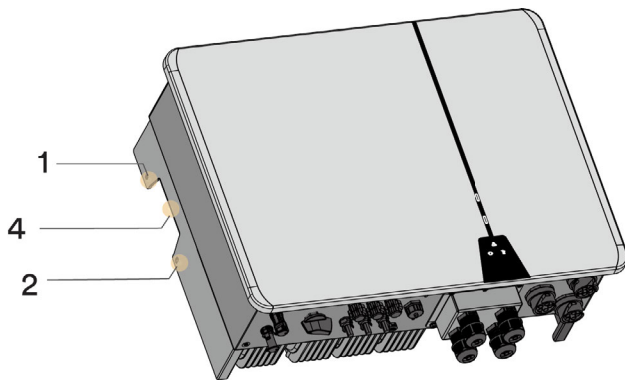

ASW05-12kH-T2-T3-DG

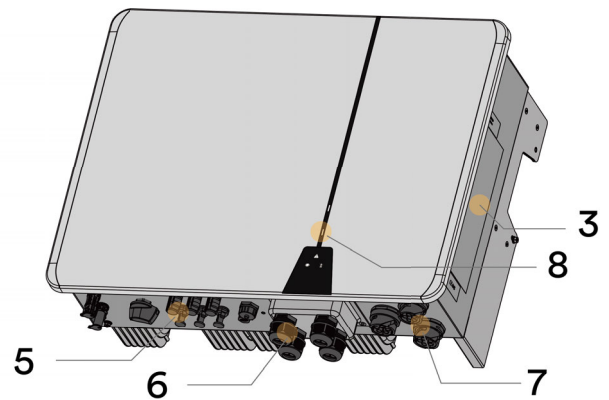
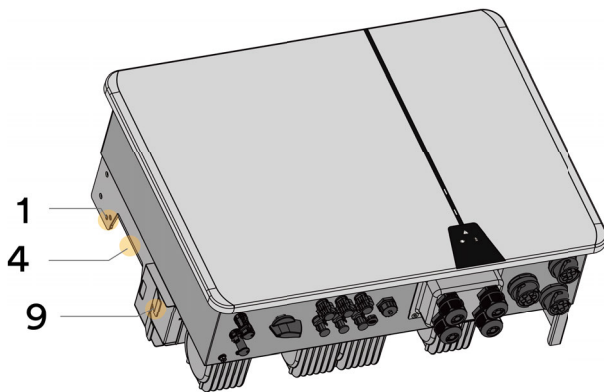

ASW15kH-T3-DG

The main difference in appearance between ASW15KH-T3-DG and ASW0-12KH-T2-T3-DG is the addition of a set of external fans.

Figure shown here is for reference only. The actual product received may differ!

Object	Name	Description
1	Mounting flanges	Used for mounting the inverter onto the mounting bracket
2	Inverter fixed point	Two points, used for the fixed connection between the inverter and the mounting-bracket.
3	Labels	Warning symbols, nameplate, and QR code.
4	Handles	To grip and hang the inverter onto the mounting-bracket.
5	DC wiring area	DC switch, DC terminals and BAT terminals.
6	Communication wiring area	WIFI terminals and communication cover.
7	AC wiring area	GRID terminals, EPS Load terminals and GEN terminals.
8	Display area	LED indicator and display panel.
9	External fan assembly	It is used for the quick replacement of the external fan module.

4.2 Dimensions

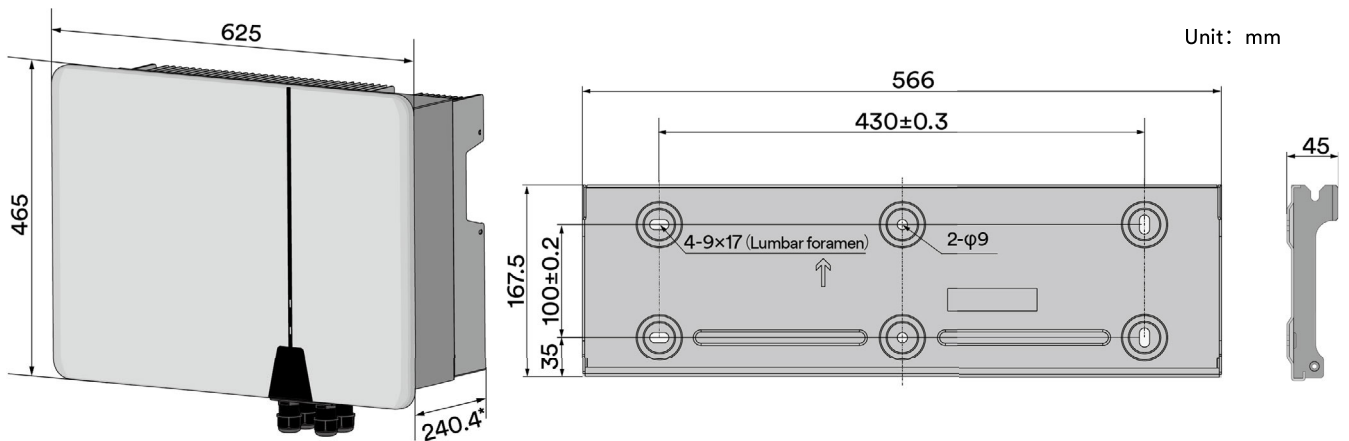

*ASW05-12kH-T2/T3 : 240.4mm

ASW15kH-T3 : 245mm

4.3 LED indicator

Function	LED	Description
SOLAR	Glowing	The product operates normally and the solar energy is available.
	Flashing	The product is self-checking automatically, or the firmware is updating.
	Off	The solar energy is not available.
BAT	Glowing	The product operates normally and the battery energy is available.
	Flashing	The product is self-checking automatically, or the firmware is updating, or the SOC of the battery is low.
	Off	The battery energy is not available.
ERR	Yellow Glowing	The communication with the Ai-Dongle has failed.
	Yellow Flashing	There is a warning fault, the warning message and the corresponding event number will be displayed on the product user interface.
	Red Glowing	There is an error fault. The Error message and the corresponding event number will be displayed on the product user interface.
	Off	The product is operating normally.
EPS	White Glowing	The EPS port of the product operates with the loads.
	White Flashing	The EPS port of the product operates without the loads.
	Red Glowing	The EPS port of the product has failed.
	Red Flashing	The EPS port of the product operates with overload.

	● Off	The EPS port of the product stop operation.
GRID	☀ White Glowing	The product connects to theis connected and feeding into the utilit Grid and feeds the solar energy into the utility grid.
	☀ White Flashing	The product doesn't connect to the grid and operates as an off-grid mode.
	☀ Red Glowing	The product disconnects from the Grid due to a fault.
	● Off	The product stop operation.

For safety reasons, EPS LED white flash when there is no load or when the load power is low.

4.4 Supported grid types

The grid network types supported by the product is TN-S, TN-C, TN-C-S, TT, as shown in the figure below:

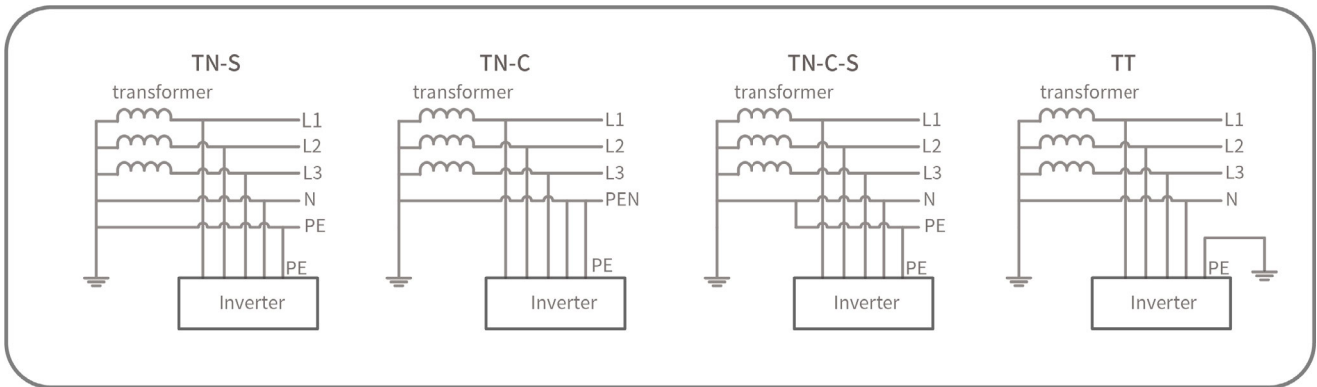

For the TT grid structure, the effective value of the voltage between the neutral wire and the ground wire must be less than 20 V.

4.5 Interfaces and functions

The product is equipped with the following interfaces and functions:

Ai-Dongle

The product is equipped with an Ai-Dongle as standard, which provides a user interface for configuring and monitoring the product. The Ai-Dongle can connect to the internet via WLAN or an ethernet cable. Solplanet communication products or a third-party monitoring device can be used if the Ai-Dongle is not connected.

RS485 Interface

The product equipped with several RS485 interfaces. Some RS485 interfaces are available via RJ45 ports and other RS485 interfaces are available via terminal blocks.

Terminal-5 and Terminal-6 ports (see section 6.9.1): Two RS485 interfaces are used for parallel operation of more than two inverters in a daisy chain. The data of all the slave inverters is communicated to the master inverter through the RS485 interfaces. The master inverter transfers the data to the internet via the Ai-Dongle.

RJ45-3 port (see section 6.9.1): This RS485 interface can be used to connect the inverter to a third-party monitoring device.

Terminal-2 (see section 6.9.1): This RS485 interface (Pin1 and Pin2) is used to connect to the smart meter. The supplied CT's are not required when the smart meter is installed.

RS485/CAN (Controller Area Network) Interface

The product is equipped with several RS485/CAN interfaces.

RJ45-4 port (see section 6.9.1): This interface is used to connect the BMS (Battery Management System) of the battery (see section 6.9.1). If the communication interface of the BMS is CAN interface, the pins for CAN interface can be chosen to connect.

RJ45-5 and RJ45-6 ports (see section 6.9.1): Two RS485/CAN interfaces used to the product parallel operation. The control information can be exchanged between the master inverter and the slave inverter through the RS485/CAN interfaces. Both the pins for RS485 interface and CAN interface shall be chosen to connect.

ETHERNET Interface

The product is equipped with an ethernet interface. The ETH interface connected through one RJ45-7 port (see section 6.9.1), and it supports TCP/IP communication protocol, which can be connected to router.

Modbus RTU

The product is equipped with a modbus interface. A third-party communication device complying with the with Solplanet Modbus protocol can be connected to the inverter.

Export power control

The product is equipped with export power limit function, so as to meet the requirements of some national standards or grid standards for limiting the output power at the grid connection point. The export power control solution measures the active power at the grid connection point and then uses this information to control the inverter's active power in order to prevent the inverter from exceeding the agreed export power limit.

The product is delivered with current transformers and a smart meter as standard. Either the current transformers or the smart meter (not both simultaneously) can be used to measure the export active power. The communication of the smart meter can be connected via RS485 (see section 6.9.1, Terminal 2).

The smart meter that can be used with this product must be approved by Solplanet. For more information about the smart meter, please contact Solplanet service.

Multifunction Relay

The product is equipped with two multifunction relays as standard. One of the relays can serve as a dry contact signal for controlling a diesel generator. When the diesel generator function in the Solplanet App is enabled and the diesel generator connection conditions are met, the open contact will switch to on (voltage free output). The second multifunction relay can be configured to operate in a specific system mode. For more information, please contact Solplanet service.

The communication interface for an external central grid protection device

The product is equipped with one communication interface (see section 6.9.1) to connect an external central grid protection device. For more information, please contact with Solplanet service.

Inverter demand response modes (DRED)

The product shall detect and initiate a response to all supported demand response commands according to the AS/NZS 4777.2 standard.

The product only supports the demand response mode DRM0. When selecting VDE 4105 in the Grid code setting, the function of ENWA 14a can be realized. The interaction with a demand response enabling device (DRED) can be connected to terminal block 3 (see section 6.9.1). Pin 5 and Pin 6 of the terminal block 3 represents the REF GEN/0 and COM LOAD/0.

Ripple control receiver interface

The product is equipped with one interface to connect a Ripple Control Receiver device (see section 6.9.1).

Current transformer interface

The current transformers can be used to measure the active power at the of grid connection point. The three current transformers can be connected to terminal block 4 (See section 6.9.1).

EPS/Back-up function

The inverter has back-up function which acts as an emergency power supply (EPS). The back-up function ensures that the inverter continues to provide three phase power to supply emergency loads in the event

of a utility grid failure ,via the EPS output. Power is provided by the battery and the PV array.

During back-up mode, battery can continue to be charged from PV array.

As soon as the utility grid is available again, the product will automatically re-connect to the grid and resume supplying power to the loads connected on the grid side.

Earth fault alarm

This product complies with IEC 62109-2 clause 13.9 for earth fault alarm monitoring. If an earth fault alarm occurs, the red color LED indicator will light up. At the same time, the error code 38 will be sent to the Solplanet Cloud.

4.6 Basic system solution

The product is a high-quality inverter which can convert solar energy to AC energy and store energy into battery. The product can be used to optimize self-consumption, store energy in the battery for future use or feed into public grid. A diesel generator interface allows a generator to charge batteries and power the loads connected to the EPS port.

The basic application of this product as follow:

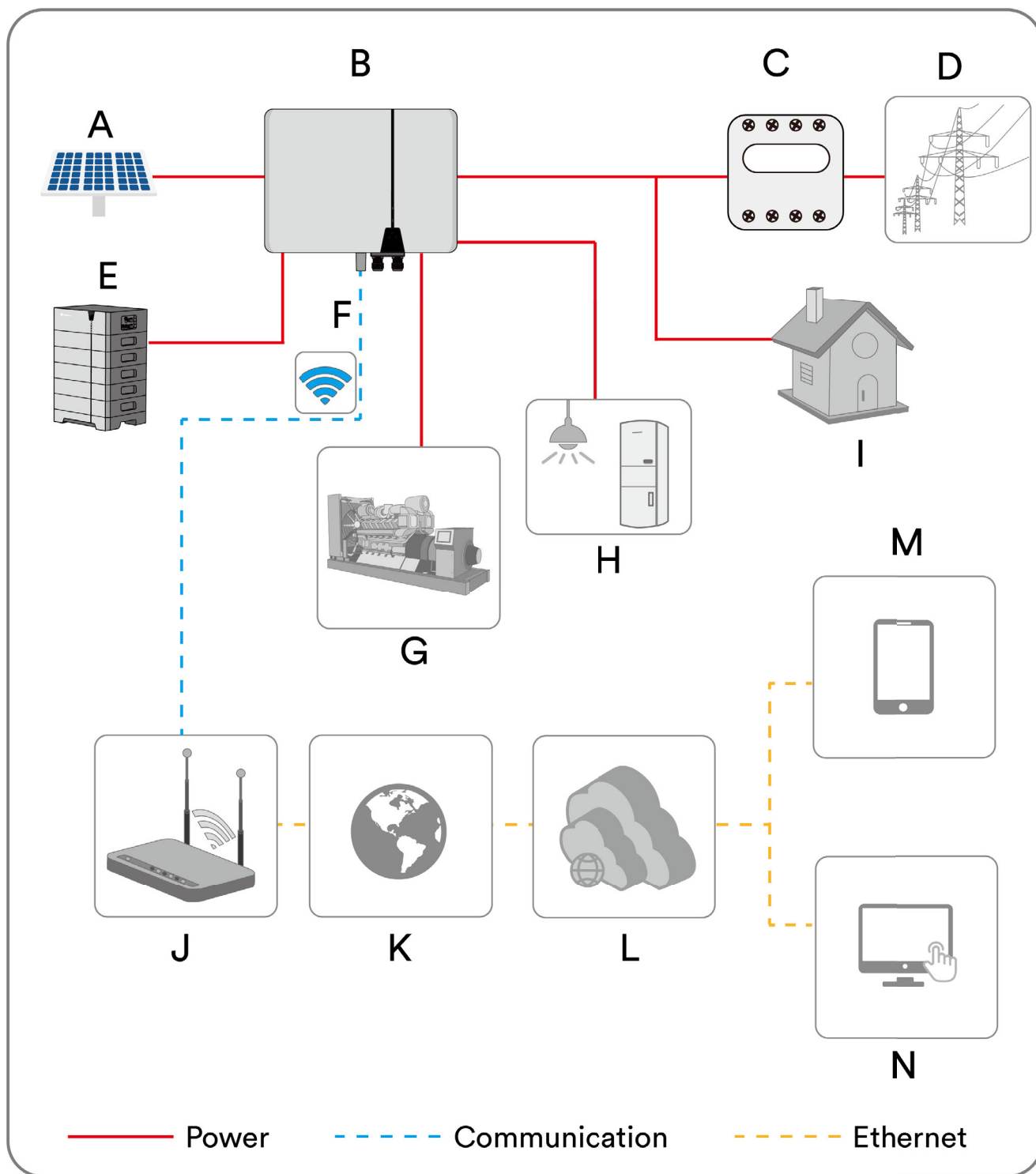

Object	Description	Remark
A	PV array	The product can connect to monocrystalline and polycrystalline silicon based PV modules and thin-film modules that require no functional grounding.
B	Hybrid inverter	ASW 5~12kH-T2-DG and ASW8~15 kH-T3-DG series products.
C	Smart meter	The smart meter measures the power at the point of connection. The smart meter also can be replaced by three current transformers which connect directly to inverter.
D	Utility grid	The product can connect to TN and TT grid network types.
E	Battery system	The product must only be operated in connection with an intrinsically safe lithium-ion battery system approved by Solplanet.
F	Ai-Dongle	The Ai-Dongle supports ethernet and WLAN communication. It is not recommended to use both communication methods at the same time.
G	Diesel generator	The product can connect to diesel generator. Batteries can be charged and EPS loads can be supplied by the diesel generator.
H	EPS Load	The EPS loads directly connect to the EPS port of the inverter. The EPS loads can be supplied by power by the inverter when there is a grid failure.
I	Normal load	The normal load directly connected to the utility grid. The normal load will not be supplied with power when there is a grid failure.
J	Router	The product can connect to router via Wi-Fi or an ethernet cable.
K	Internet	The inverter and battery data is sent to the Solplanet Cloud via the Internet.
L	Cloud server	The inverter and battery data is stored on the Solplanet cloud server.
M	Smart Mobile Device	The Solplanet app can be installed on a smart mobile device to view the PV plant information.
N	Computer	The inverter and battery data can also be viewed via a computer which is logged into the Solplanet cloud desktop web application.

The system diagram of this product as follow:

For Australia and New Zealand, the neutral cable of the On-grid side and EPS side must be connected together according to the wiring rules AS/NZS 3000, otherwise the EPS function will not work.

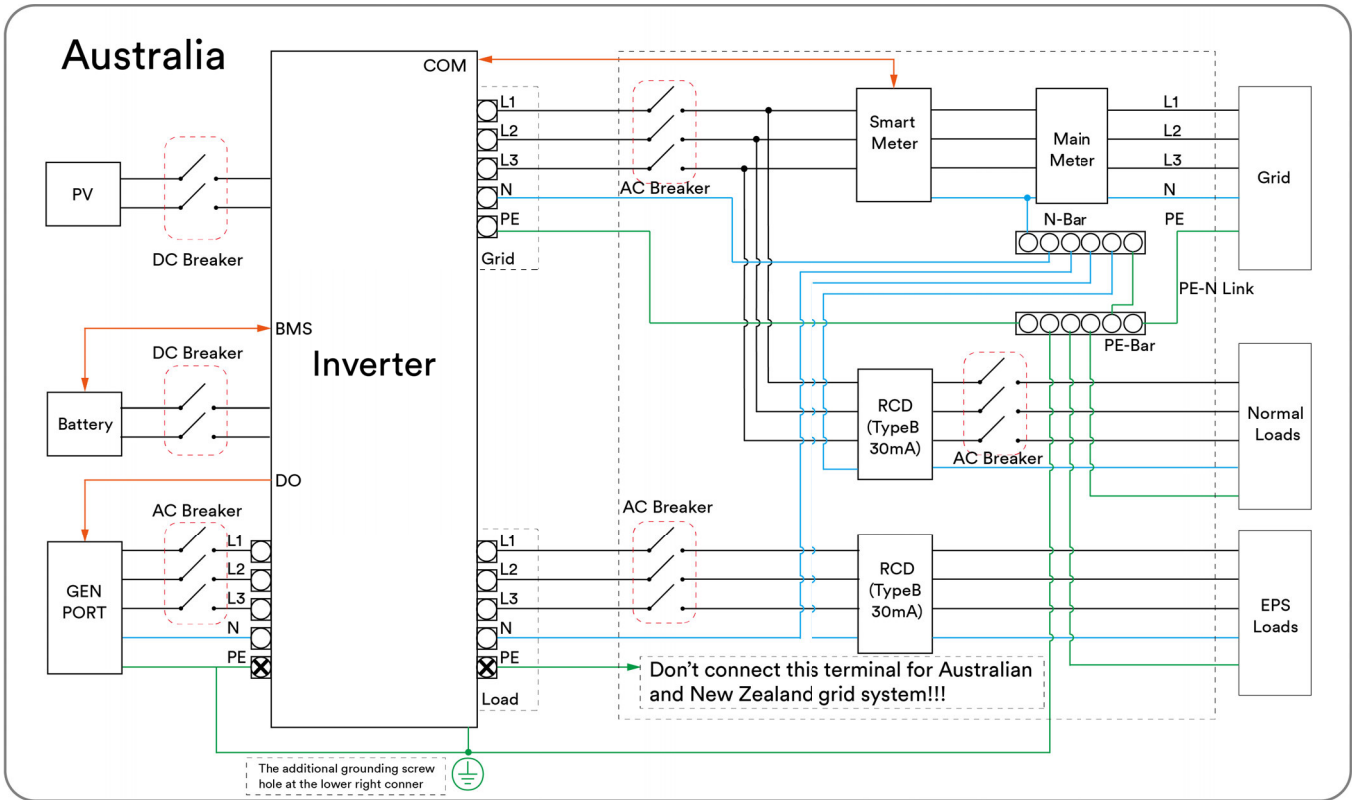

For other countries, the following diagram is an example for grid systems without special requirement on wiring connection.

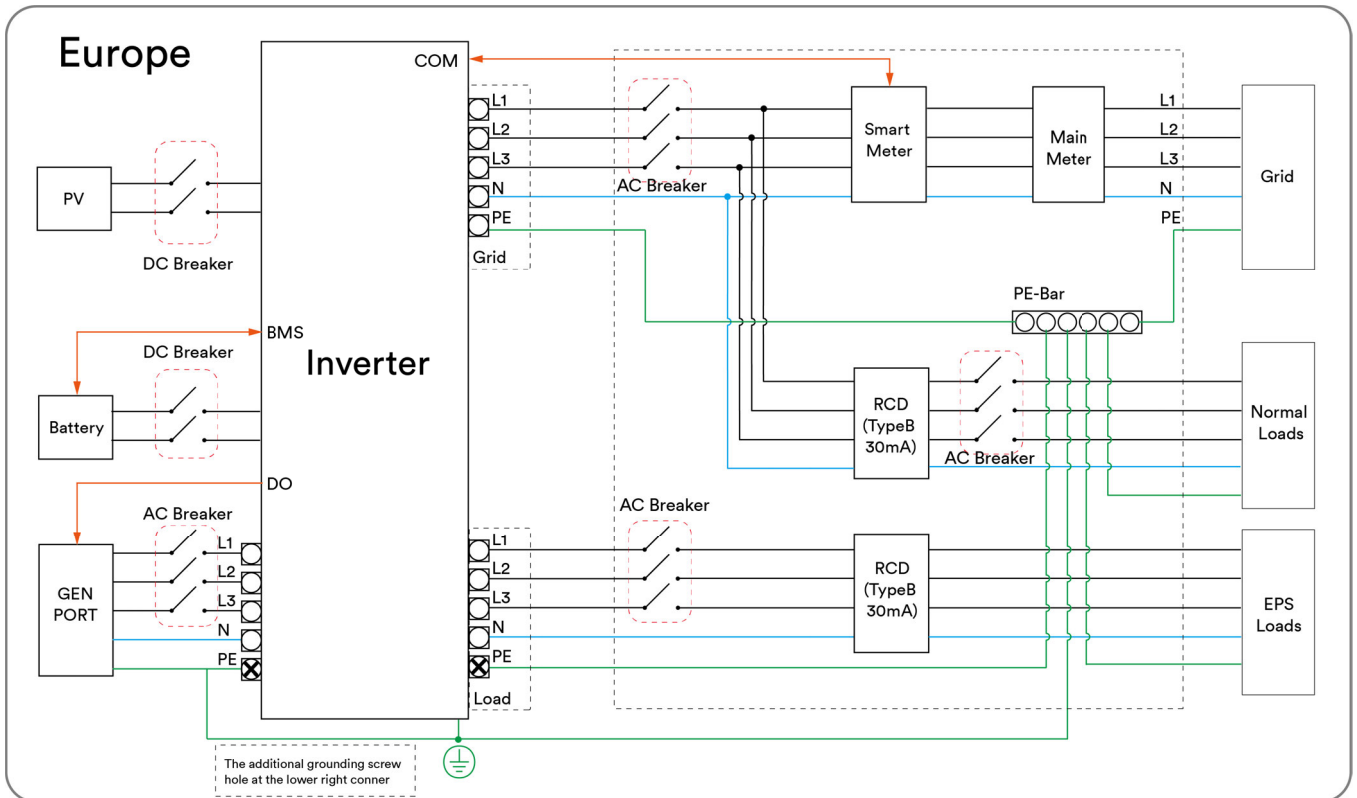

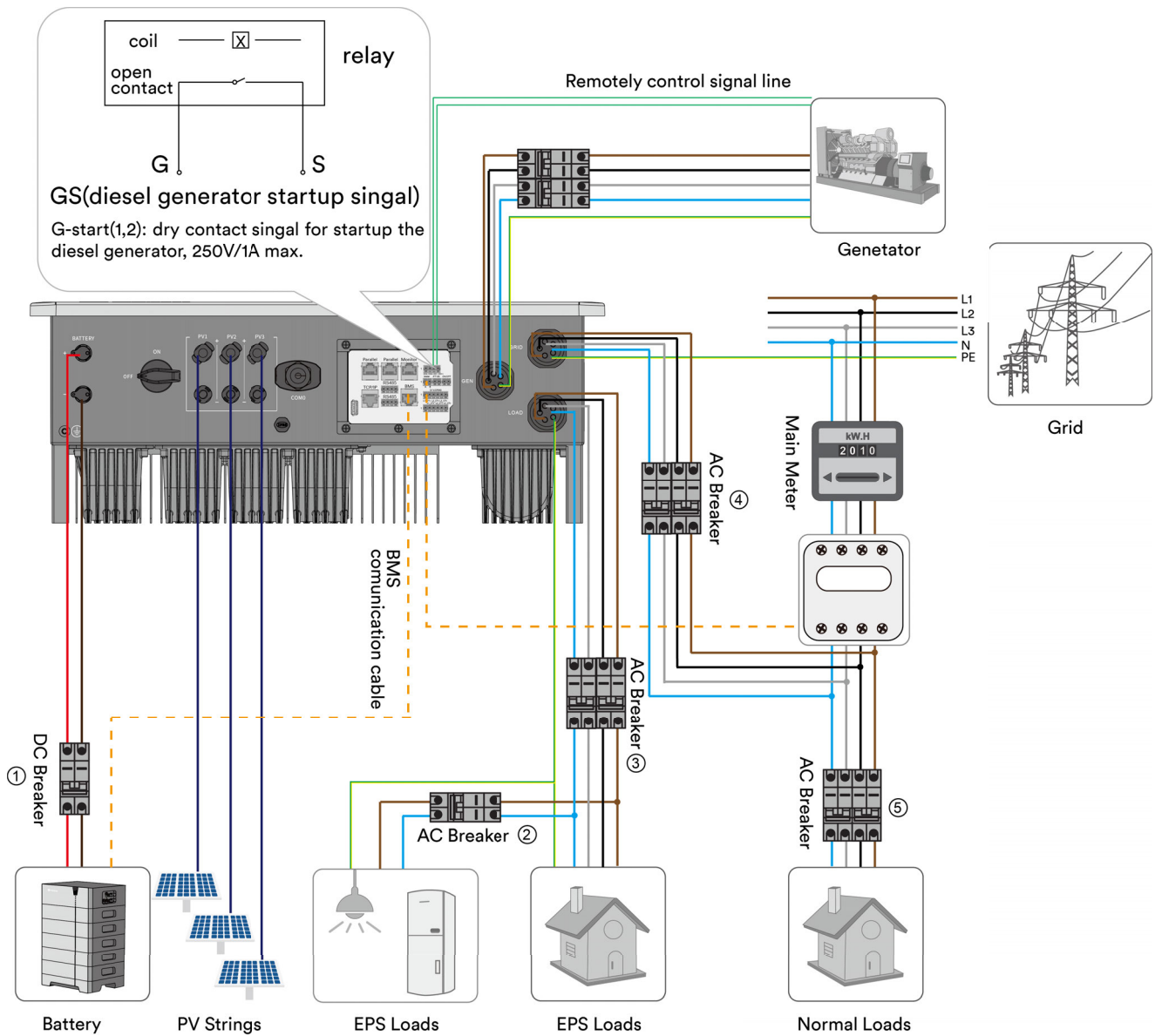

	5kW	6kW	8kW	10kW	12kW/15kW
1	63Amax/600v DC Breaker				
2					
3	20A/400V AC Breaker	25A/400V AC Breaker	32A/400V AC Breaker	32A/400V AC Breaker	40A/400V AC Breaker
4					
5	Depends on household				

4.7 Energy Management

The energy management mode depends on PV energy and the user's preference. There are four energy management modes that can be chosen.

Self-Consumption mode

Self-consumption prioritises the supply of the local load with PV and battery energy to resulting in an increase of the self-consumption and self-sufficiency rates. The Self-consumption mode normally relies on the smart meter or CT for power dispatching. However, when the communication or data of the smart meter or CT is lost, a warning of smart meter loss will be issued. At this point, the inverter will use the power at the grid port calculated by internal sampling to replace the power of

the smart meter or CT, completing the power dispatching.

The energy management during daytime:

Case 1: PV power generation is lower than the load power consumption and there is no available battery energy. The balance of load power, if any, is supplied from the grid.

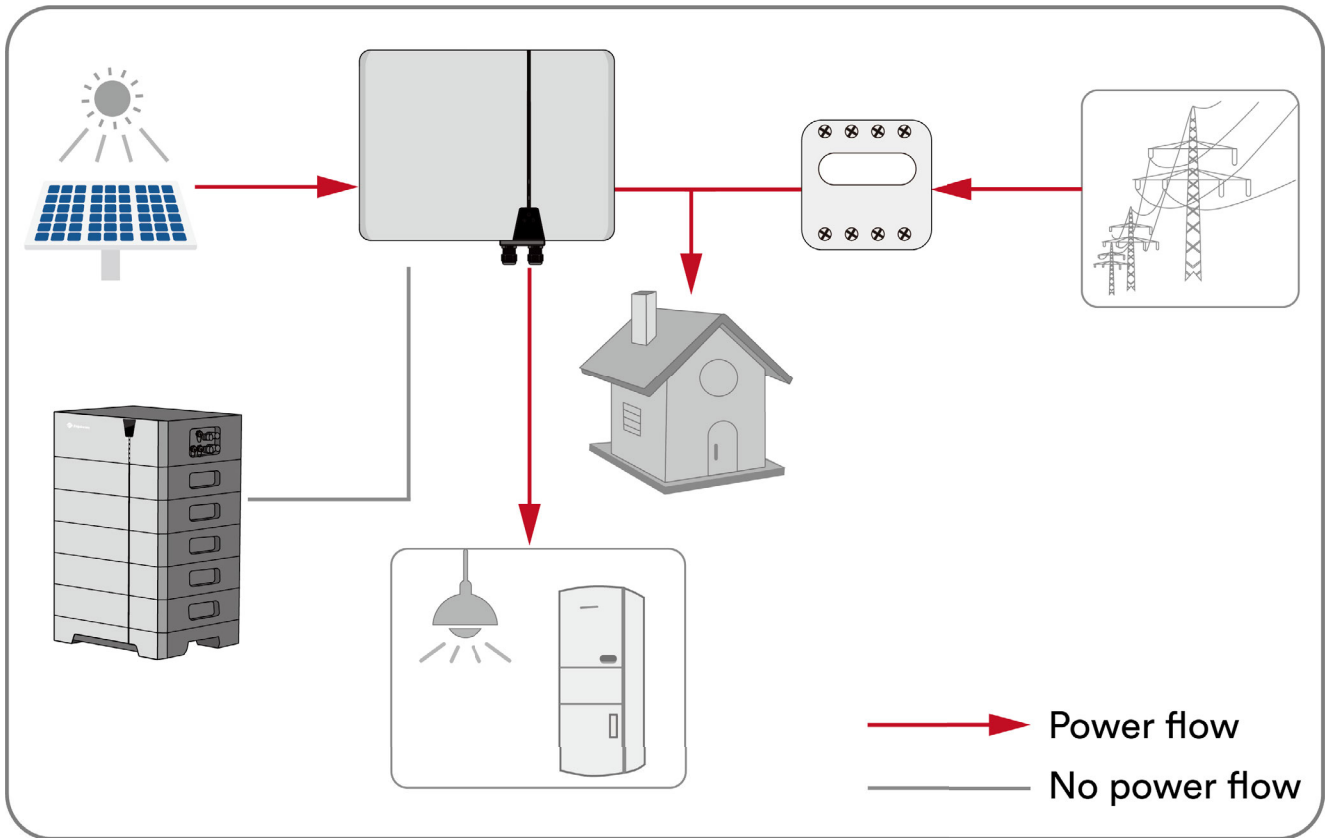

Case 2: PV power generation is lower than the load power consumption and there is available battery energy. The balance of load power, if any, is supplied from the grid.

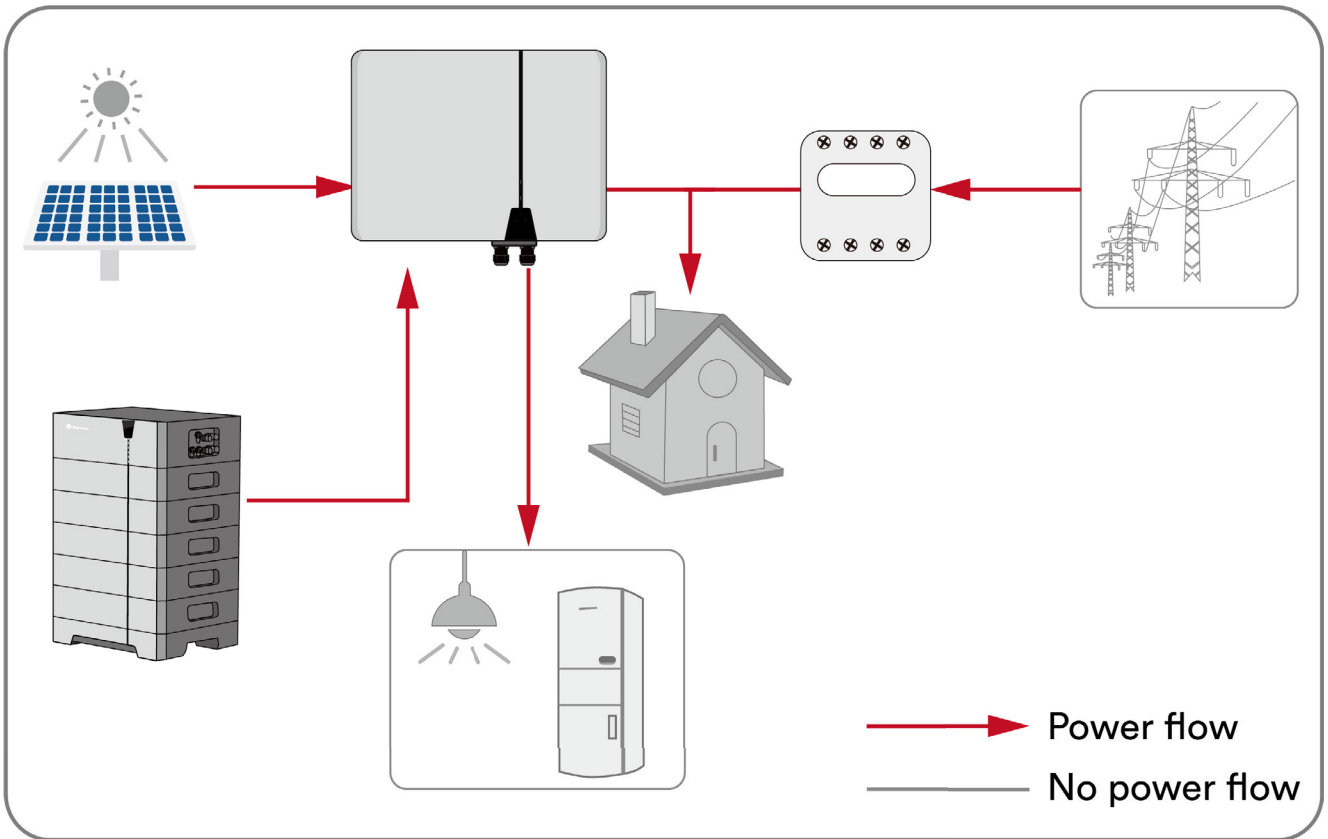

Case 3: PV power generation is larger than the load power consumption. Battery charging via PV energy is prioritised. PV energy is exported to the grid if it is greater than the load power consumption and when the battery is completely charged.

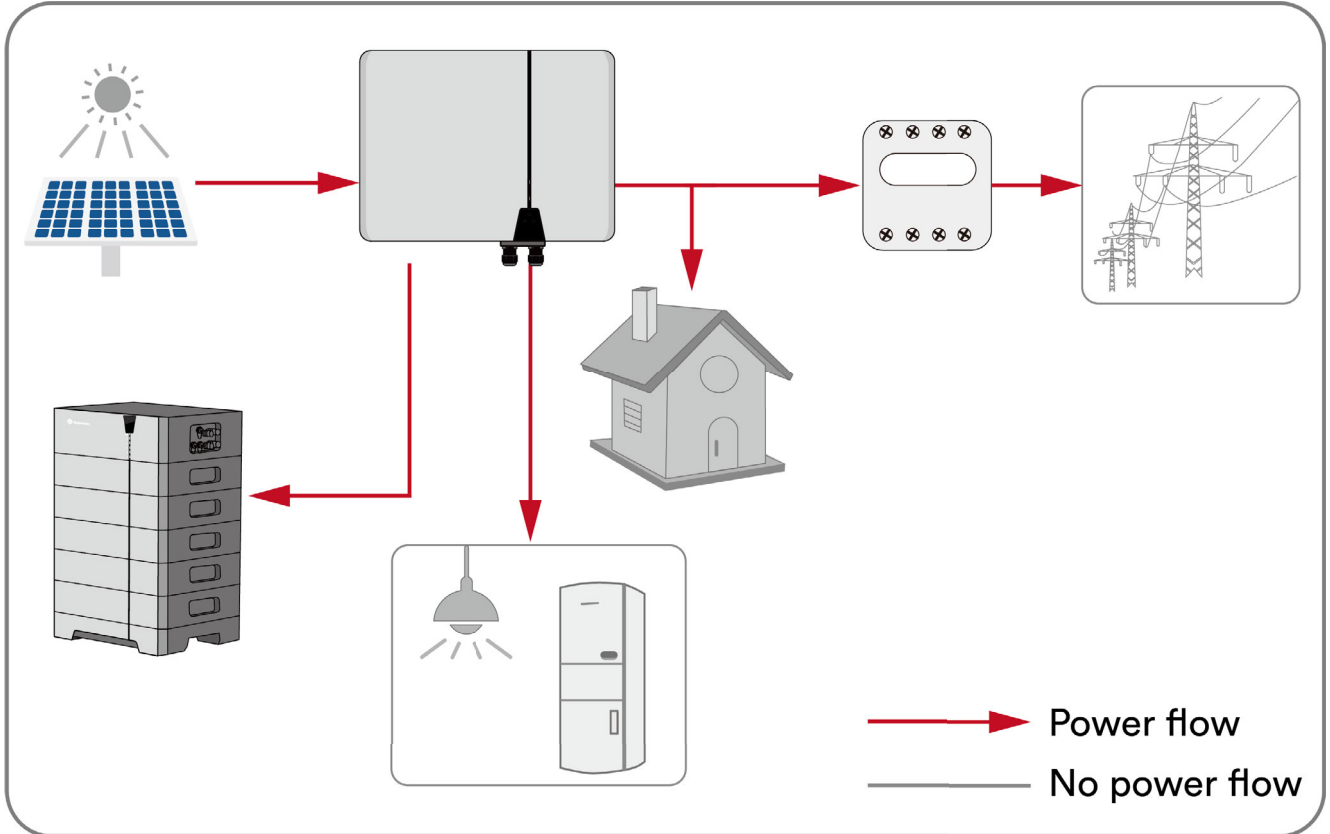

The energy management during night:

Case 1: Battery energy is available. The load power consumption will be supplied by the battery and the balance, if any, will be supplied by the grid.

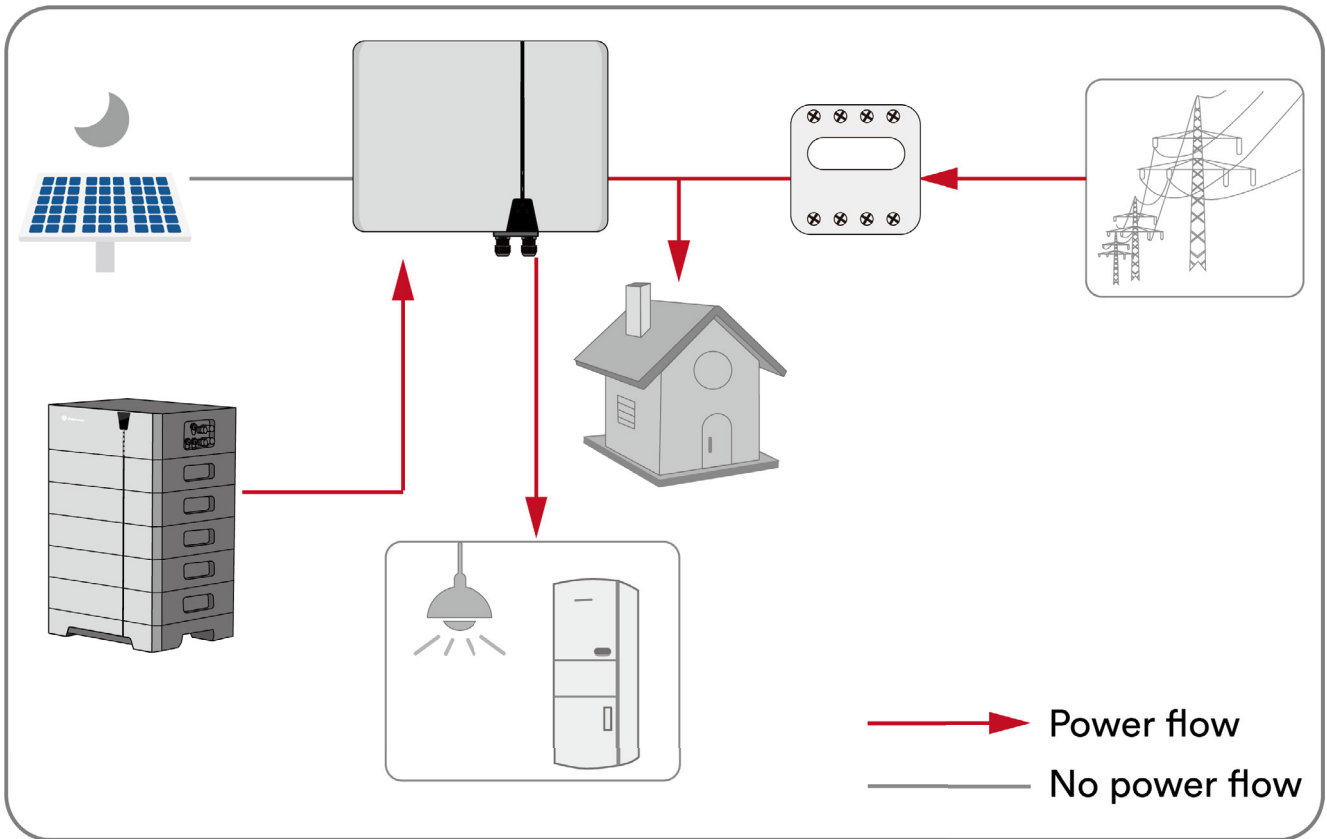

Case 2: Battery energy not available. The load power consumption will be supplied by the grid.

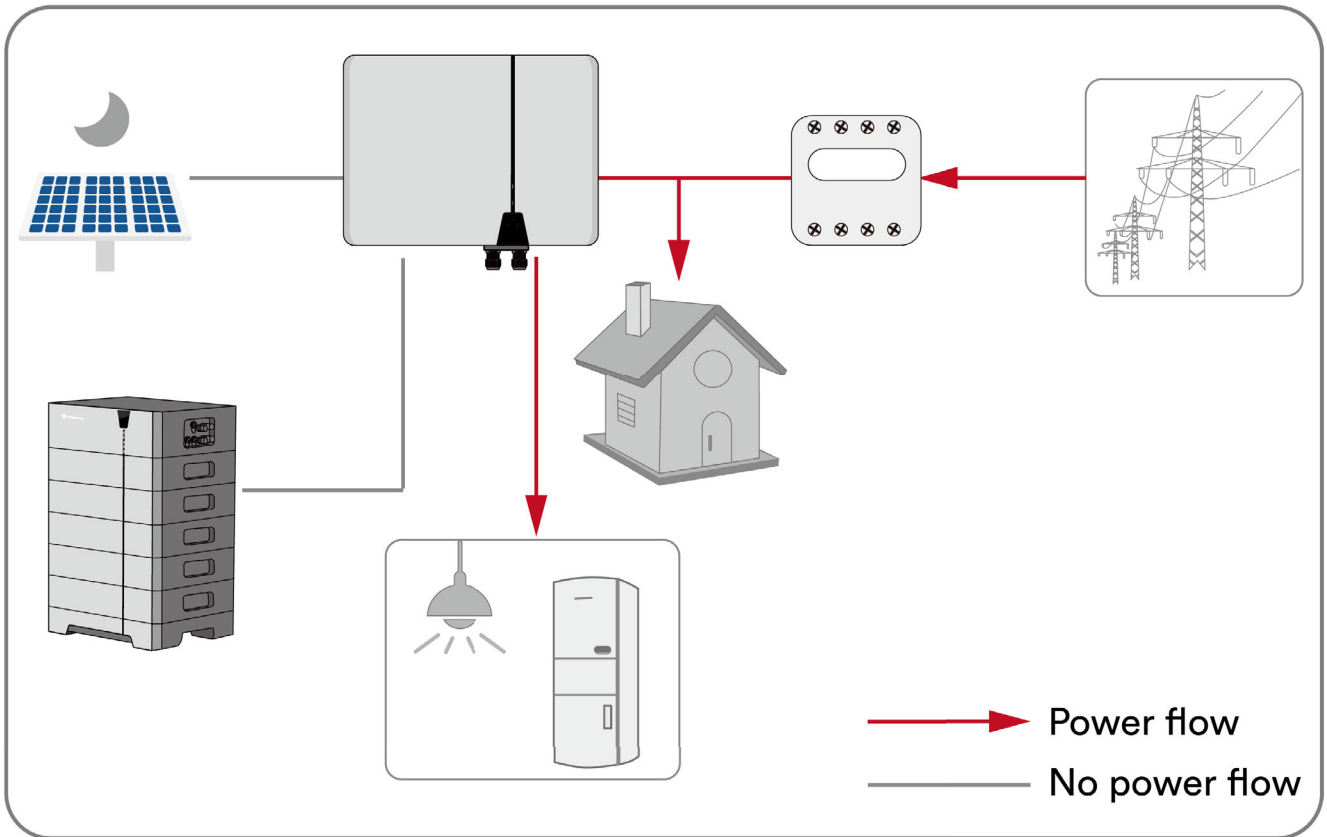

Reserve mode

The battery is regarded as a back-up energy storage device. PV power prioritises the charging of the battery if it is not completely charged. The battery discharges only during a loss of the utility grid..

Case 1: The battery is not completely charged. PV power will prioritise the charging of the battery.

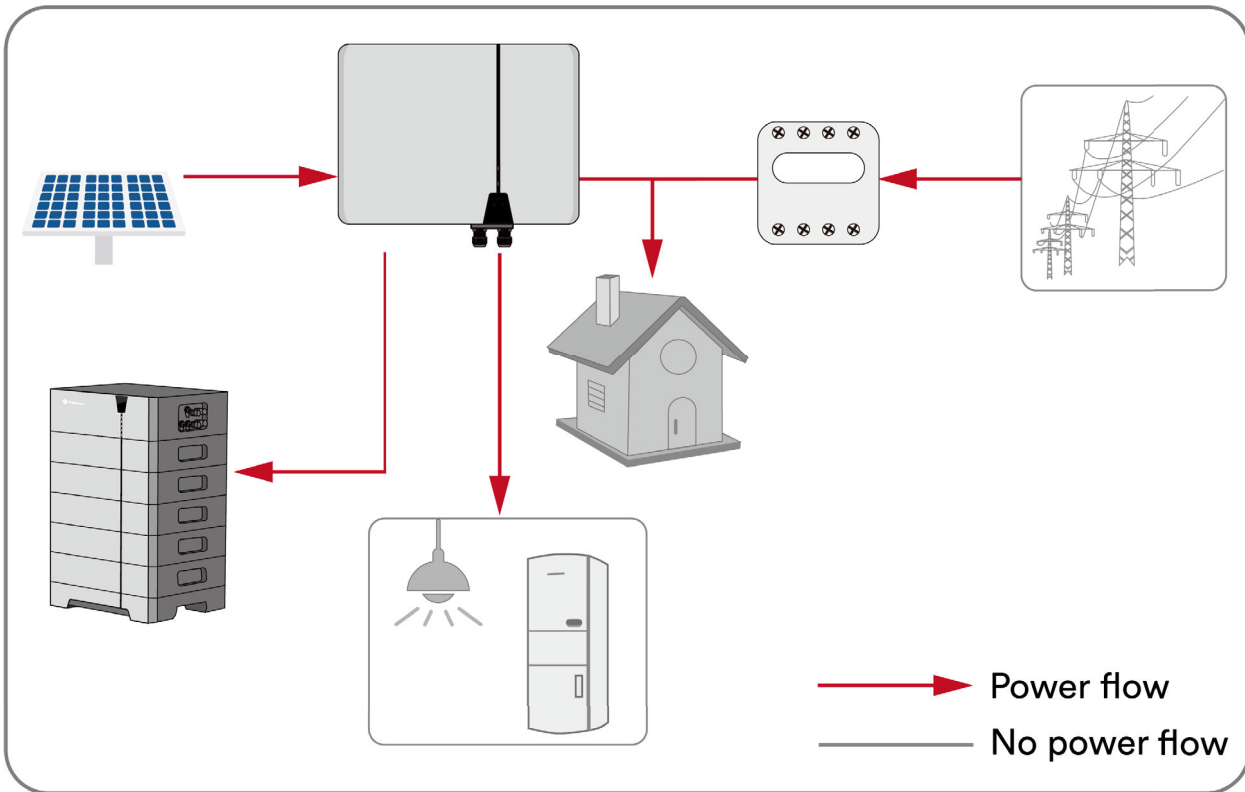

Case 2: The battery is completely charged, the load power consumption is supplied by excess PV power and the balance, if any, is supplied by the grid.

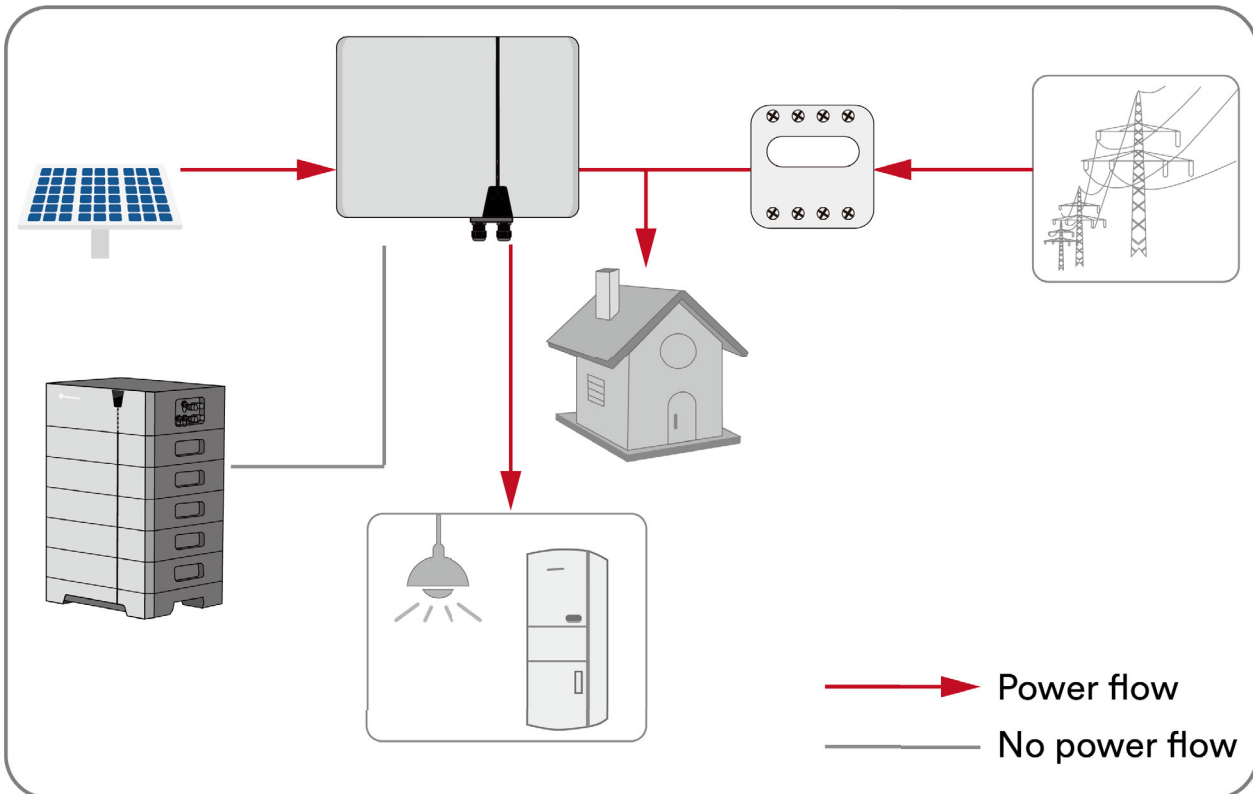

Case 3: The battery discharges when there is a loss of the utility grid.

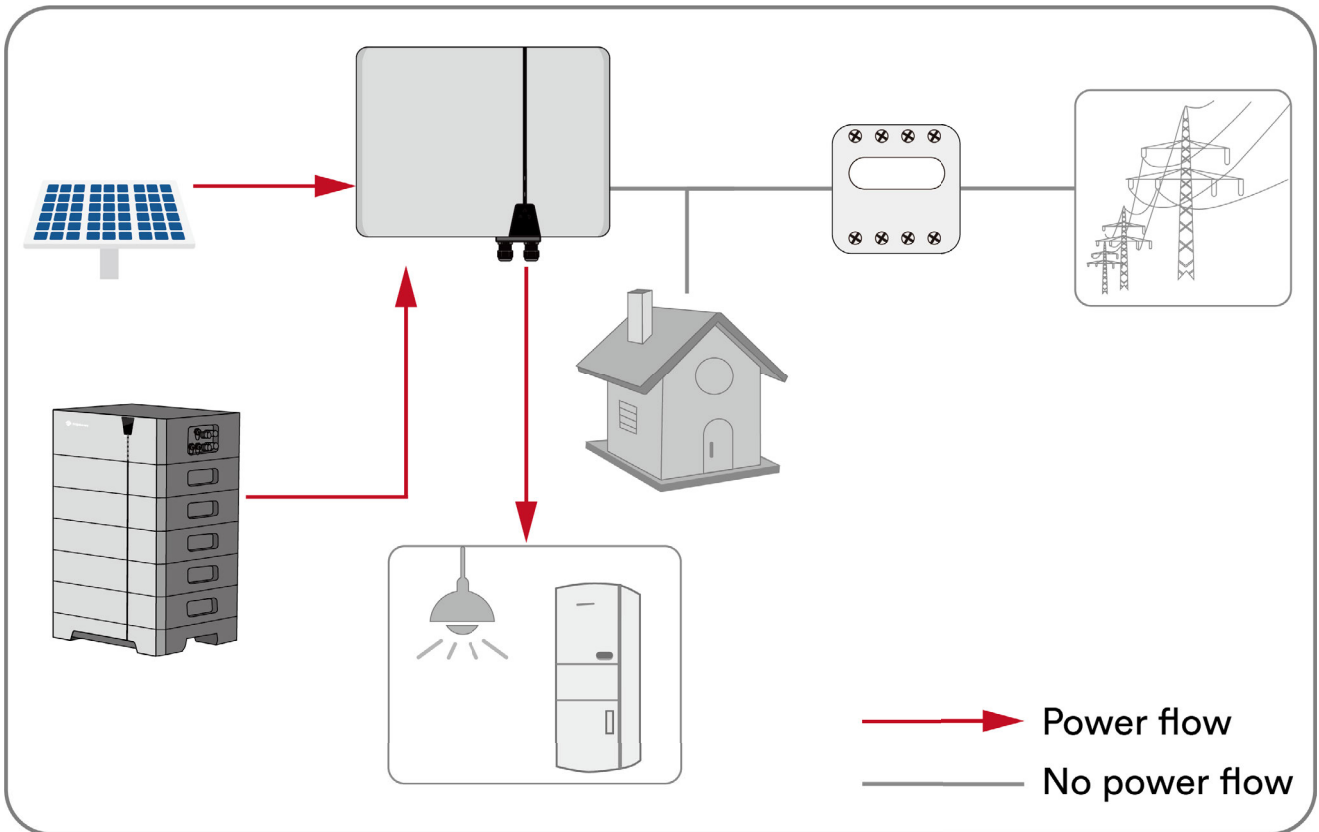

With Generator

A diesel generator is connected to the inverter. The inverter will send a command to start the generator when grid loss, the battery soc is too low and if PV energy can not support load.

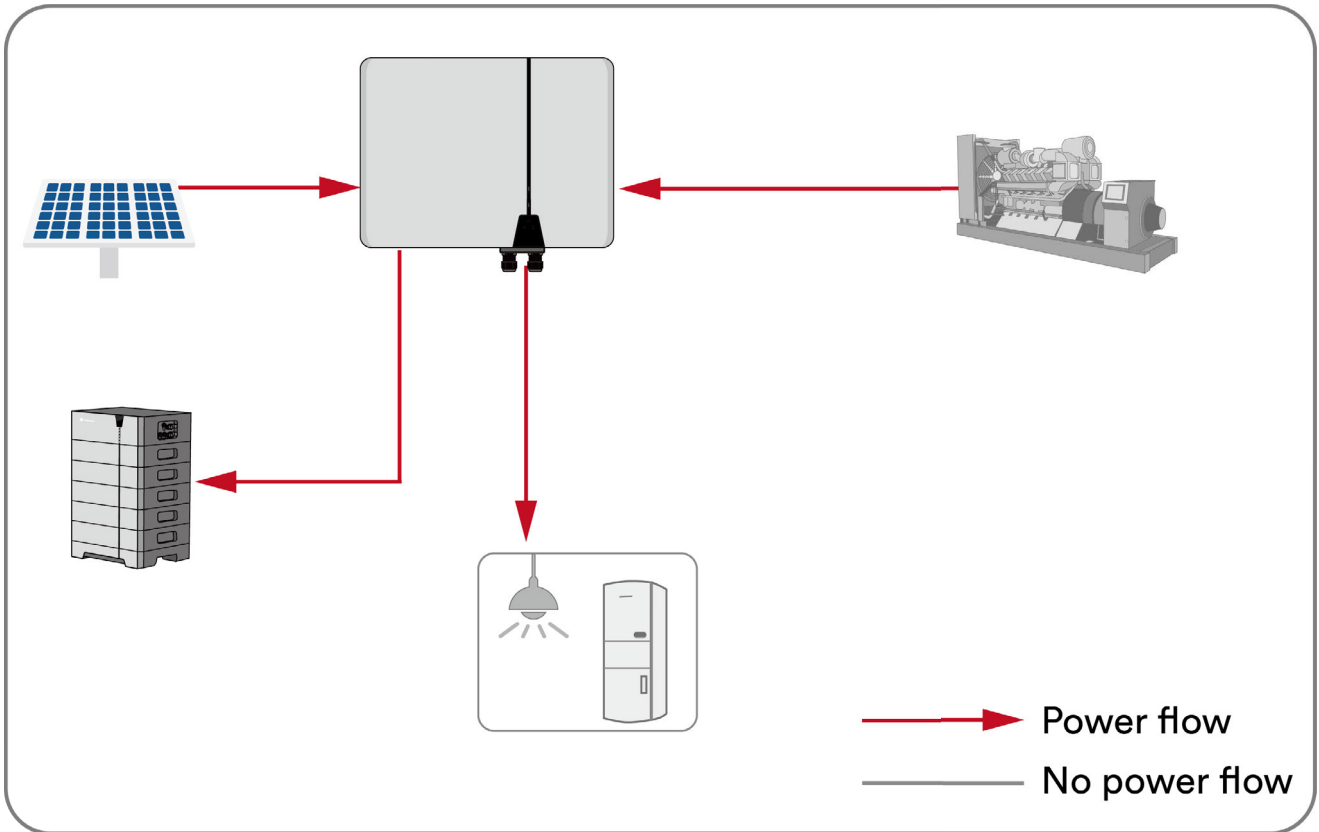

With Smart-load

When the household load is connected to the generator terminal, the system can determine whether to connect or disconnect the load of the port based on the battery SOC value set by the user.

The smart load mode mainly refers to the load that does not need continuous power supply in the customer's access home. The load can only be used when the customer thinks that the energy is sufficient. For example, when the SOC value of the battery is greater than the customer's set value, the energy of the grid, PV or battery can supply power to the smart load. The smart load is disconnected when the SOC value of the battery is less than the value set by the customer.

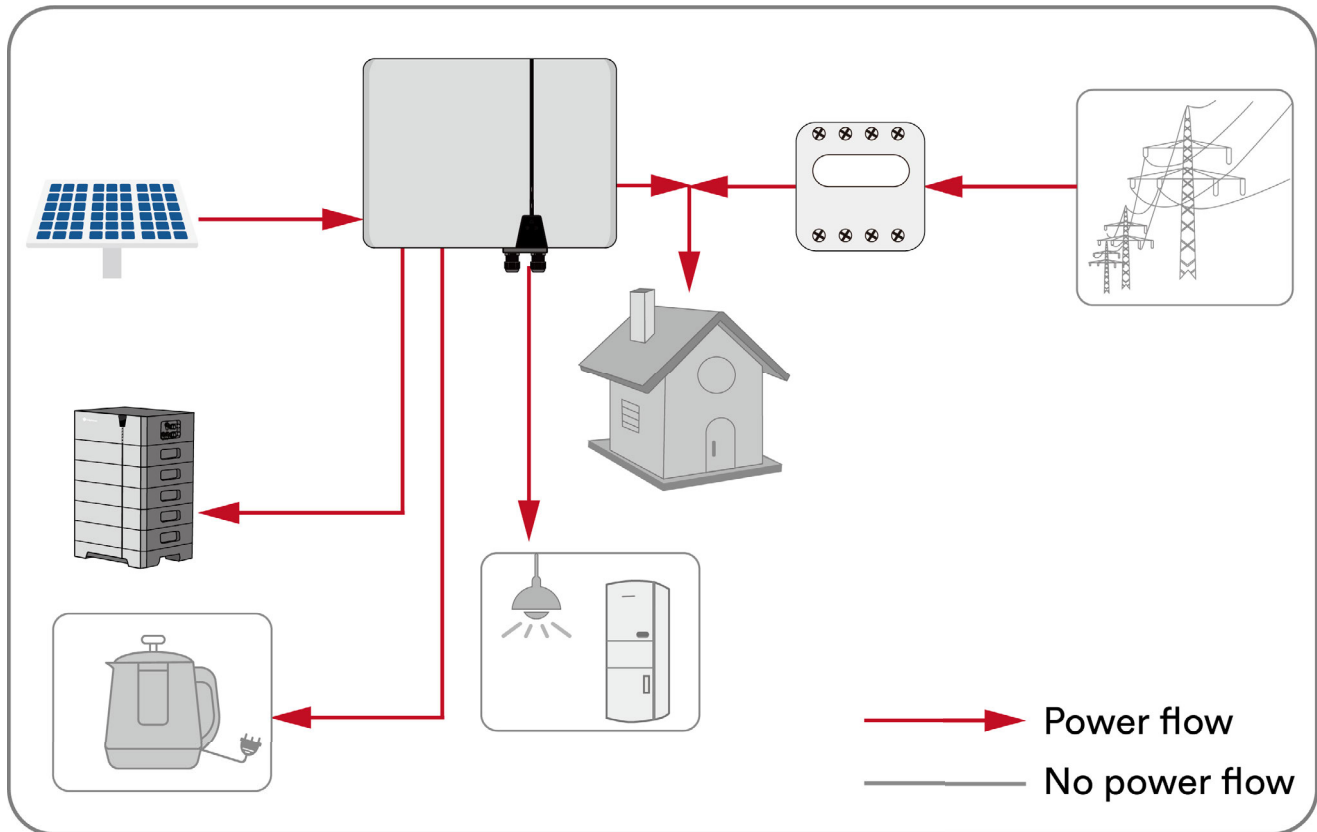

Off-grid mode

The product operates as a stand-alone inverter. Power is only supplied via the EPS port.

Custom mode

Users can manage the energy according to their own needs, and set daily regular charging and discharging schedules via the app. Outside of the schedules the system operates in self-consumption mode.

Time of use mode

If user chooses load first, then the inverter will operate in self-consumption mode when the grid charge is disabled. If grid charge is enabled then the inverter will operate in back-up mode (battery SOC below the set point) or self-consumption mode (battery SOC above the set point.)

If user chooses battery first, the PV power will first charge the battery when grid charge is disabled. If grid charge is enabled, the inverter will operate in back-up mode (when battery SOC is below the set point) or self-consumption mode (when battery SOC is above the set point).

4.8 Parallel System

The parallel function of ASW-15KH-T3-DG is under development, please contact solplanet before using parallel function.

4.8.1 Grid parallel

The hybrid inverter can operate as a parallel system. The system can even work when the utility grid is loss occasionally.

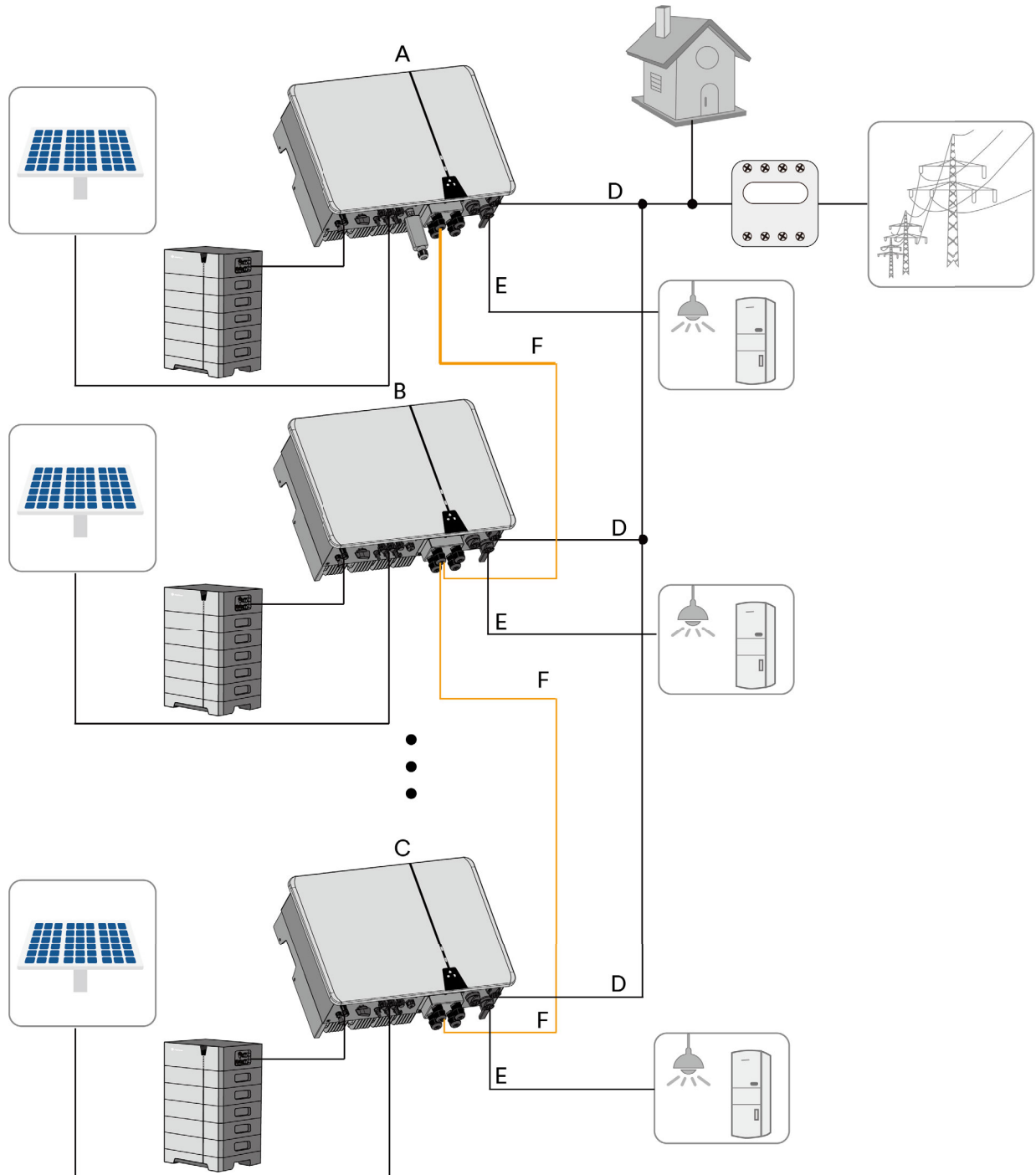

A Master Inverter	B Slaver Inverter 1	C Slaver Inverter N
-------------------	---------------------	---------------------

D Grid port	E EPS load port	F Communication cable
-------------	-----------------	-----------------------

Hybrid inverters with the same model can be connected in parallel in grid port. the EPS load should be independent of each inverter and the battery should be same model, show as follows.

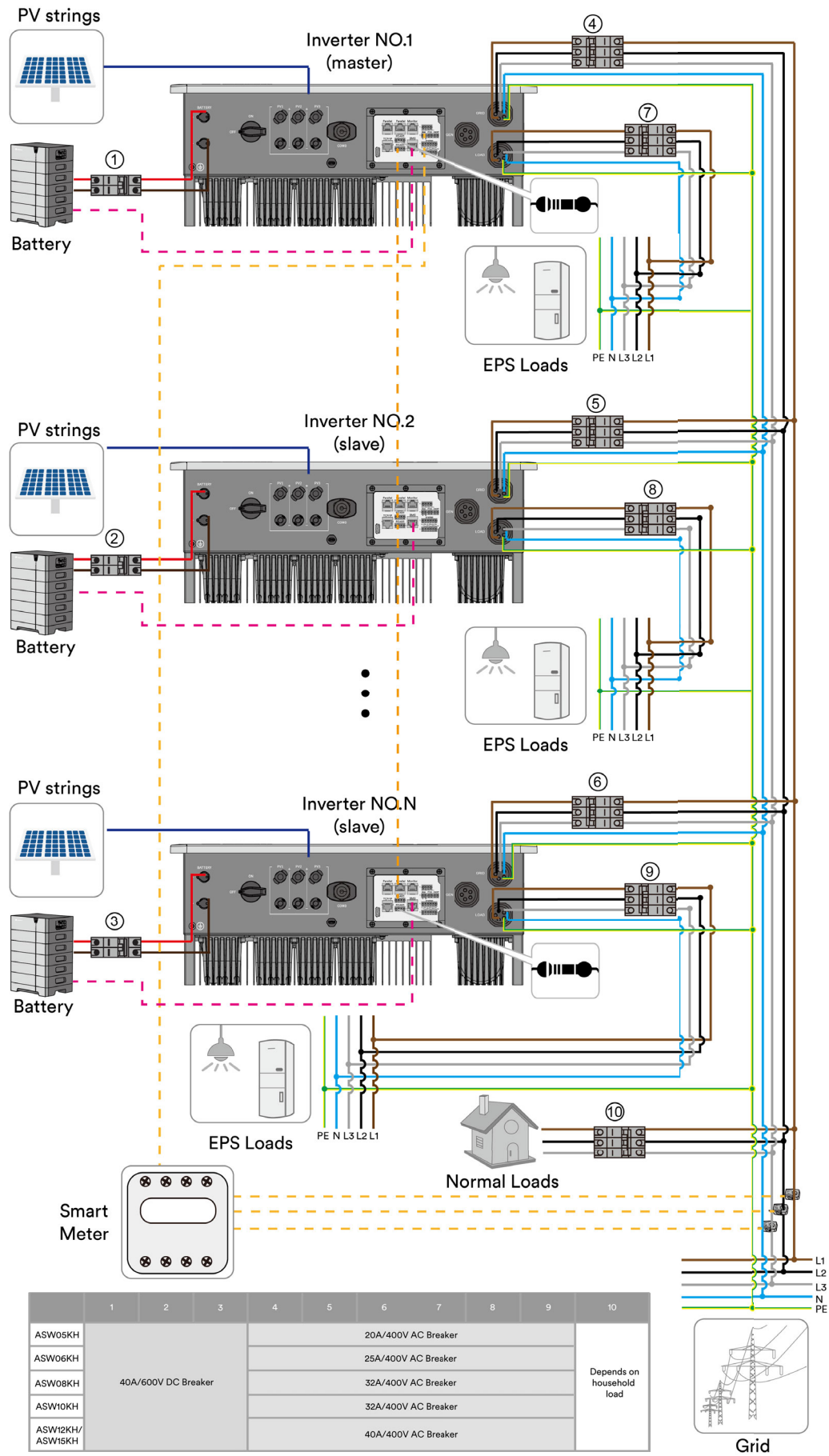

4.8.2 Grid and EPS parallel

There is another parallel solution: Grid and EPS parallel, which can support larger EPS load and can operate even when grid loss.

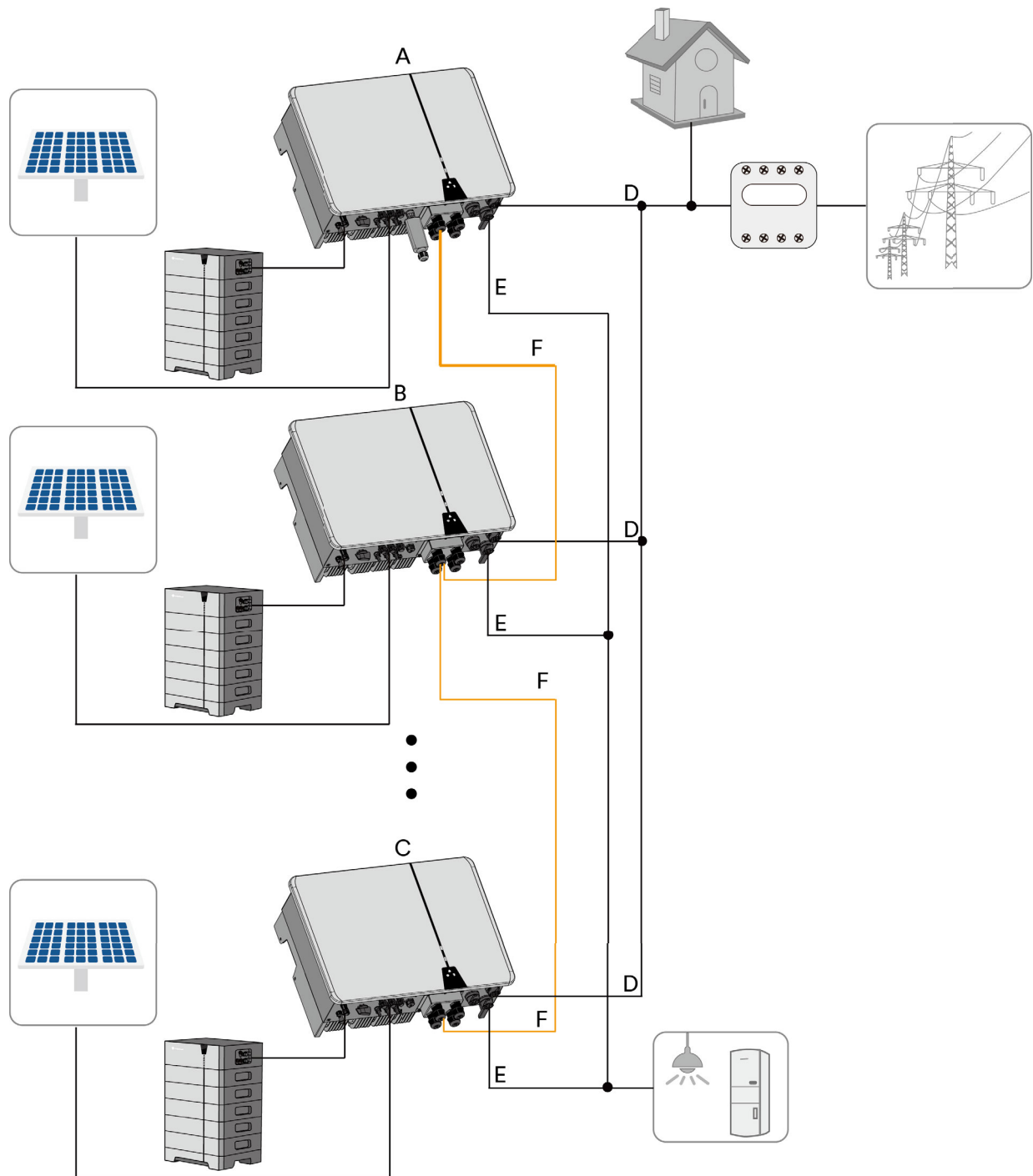

A Master Inverter	B Slaver Inverter 1	C Slaver Inverter N
D Grid port	E EPS load port	F Communication cable

Hybrid inverters with the same model can be connected in parallel in EPS port and grid port at the same time, the battery

should be same model, show as follows:

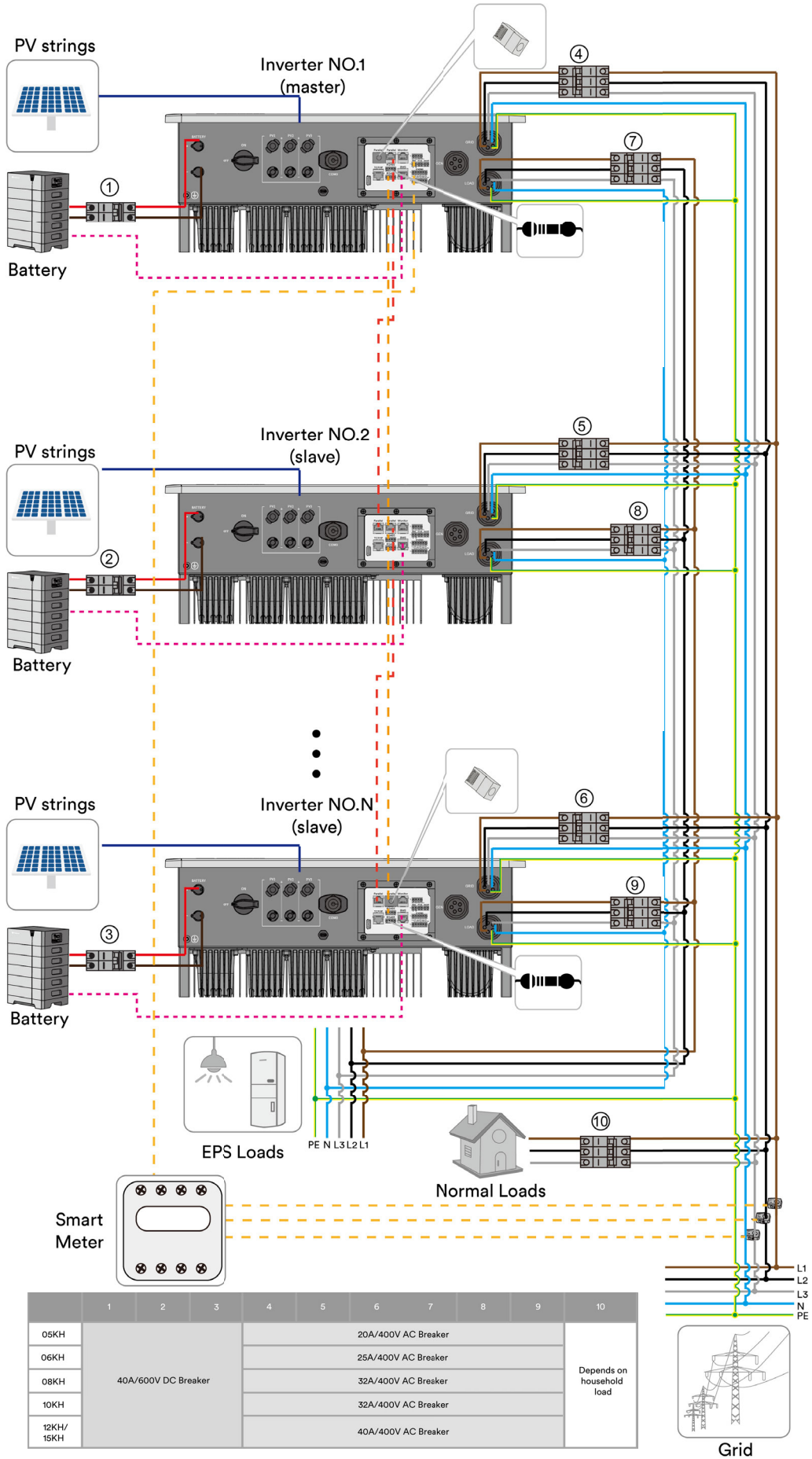

CAUTION

Risk of damage to the inverters!

Due to incorrect connection, the inverter will be permanently damaged

- The EPS phase sequence of all inverters in the parallel system must be completely consistent when **Multi machine EPS in parallel** enable, strongly recommend measure each PIN of EPS and Grid connector before commission, make sure the same phase PIN of master and slaver inverter is connected together.

The parallel system supports the following meters . Customer can install the different type meter which can meet AC bus current requirement. CT should not used in parallel system. The smart meter should connect as 3P4W wiring refer to smart meter User Manual. Recommend purchasing smart meter from Soplanet, some functions will be limited if purchased from other sources.

Manufacturer	Model	Max current	CTs
EASTRON	SDM630-Modbus V2/SDM630-M	100A	NA
EASTRON	SDM630MCT V2	250A	3*ESCT-T24 250A/1A
EASTRON	SDM630MCT 40mA	120A	3*ESCT-TA16 120A/40mA
CHINT	(PV)DTSU666 3x230/400V 5(80)A 4P	80A	NA
CHINT	(PV)DTSU666 3*220/380V 250A/50mA 4P Modbus	250A	3*CT NCTK-24 250a/50mA

NOTICE

Damage to the inverter due to wiring error.

Parallel system wiring must be performed as required, otherwise the product will not work properly or even be damaged.

- The phase sequence of the grid-side wiring of all parallel inverters must be completely consistent. If EPS is parallel , the EPS phase sequence also must be completely consistent.
- The smart meter is connected to the AC bus, that is, when multiple units are running in parallel, the system share one smart meter, and the smart meter communication line is connected to the master inverter. The entire parallel system can only use one meter. The functions of RCR and NS-protection only need to be connected to the master inverter.
- Ai-dongle and smart meter must be connected to master inverter.
- Use Ethernet cables for inverter communication to connect multiple inverters in series. The length of a single Ethernet cable should less than 20m. The wire sequence is the same at both ends of the ethernet cable , The two communication cables cannot be confused. After the wiring is completed, the empty communication ports of the first and last inverter are inserted into a RJ45 port terminal resistance in the accessory bag.
- Select the battery type in the APP of master inverter. The process steps are the same as the single inverter settings. Please refer to Chapter 8.4.
- **Multi machine EPS in parallel** in APP is for Grid and EPS parallel function , for Grid parallel function, this option must be “off”.
- The inverters in a parallel system can be left unconnected to the battery. But in EPS parallel mode, the Master inverter must be connected to the battery.

NOTICE

Adding inverters or deleting inverters in the parallel system requires re-scanning the inverter (the network cable and 120ohm matching resistor are connected according to the inverter).

- Replace the master and slave inverters on the premise that both the inverters in the parallel system are good: cut off all inverter power, move the stick and meter terminal to new master inverter, and connect the Ethernet cable and 120ohm matching resistor along with the new master inverter, and then power on, wait until the green light on the stick is always on, click to scan the inverter. After the new system is scanned out, the replacement is completed.
- When the master inverter of the parallel system is broken and all inverters are powered off, replace the master inverter: power off all the inverter, move the stick and meter to new master inverter, the Ethernet cable and 120ohm matching resistor are also connected with the replacement of the master inverter, and then all power on, wait for the green light on the stick to turn on, click to scan the inverter. After the new system is scanned out,. At this time, the replacement is completed.

NOTICE

In a parallel system, if NS-protection is triggered when the system is working off-grid mode and an exception occurs after the system recovers, need to rescan the parallel system with the app.

5 Mounting

5.1 Requirements for mounting

DANGER

Danger to life due to fire or explosion !

Despite careful construction, electrical devices can cause fires. This can result in death or serious injury.

- Do not mount the product in areas containing highly flammable materials or gases.
- Do not mount the inverter in areas where there is a risk of explosion.
- The ambient temperature below 40°C is recommended to ensure optimal operation.
- A solid support surface must be available (e.g., concrete or masonry). Ensure that the installation surface is solid enough to bear four times the weight of the inverter. When mounted on drywall or similar materials, the product emits audible vibrations during operation.
- The mounting location must be inaccessible to children.
- The mounting location should be freely and safely accessible at all times without the need for any auxiliary equipment (such as scaffolding or lifting platforms). Non-fulfillment of these criteria may restrict servicing.
- The mounting location must not be exposed to direct solar irradiation. If the product is exposed to direct solar irradiation, the exterior plastic components may age prematurely and overheating might occur. When becoming too hot, the product reduces its power output to avoid overheating.

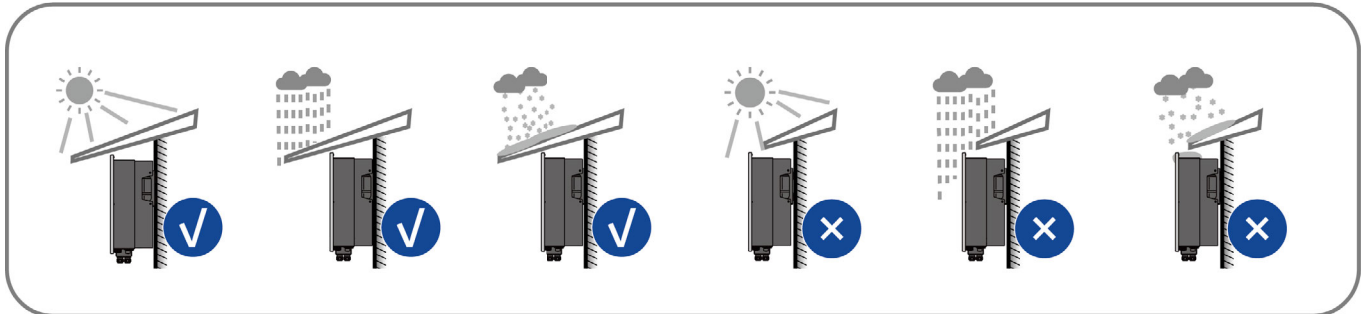

- Never install the inverter horizontally, or with a forward / backward tilt or even upside down. Horizontal installation can result in damage to the inverter.

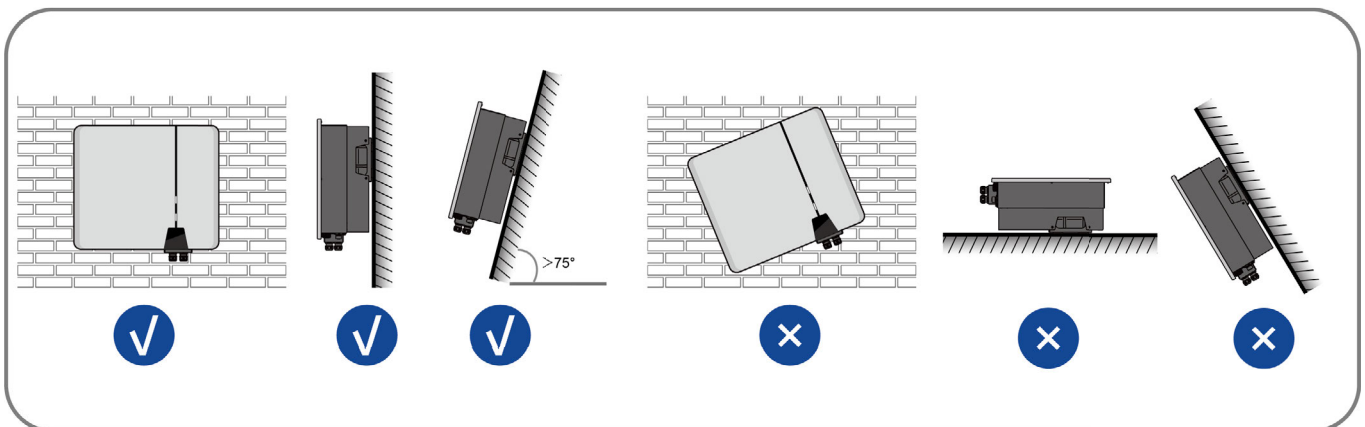

- Maintain the recommended clearances to other walls as well as to other inverters or objects.

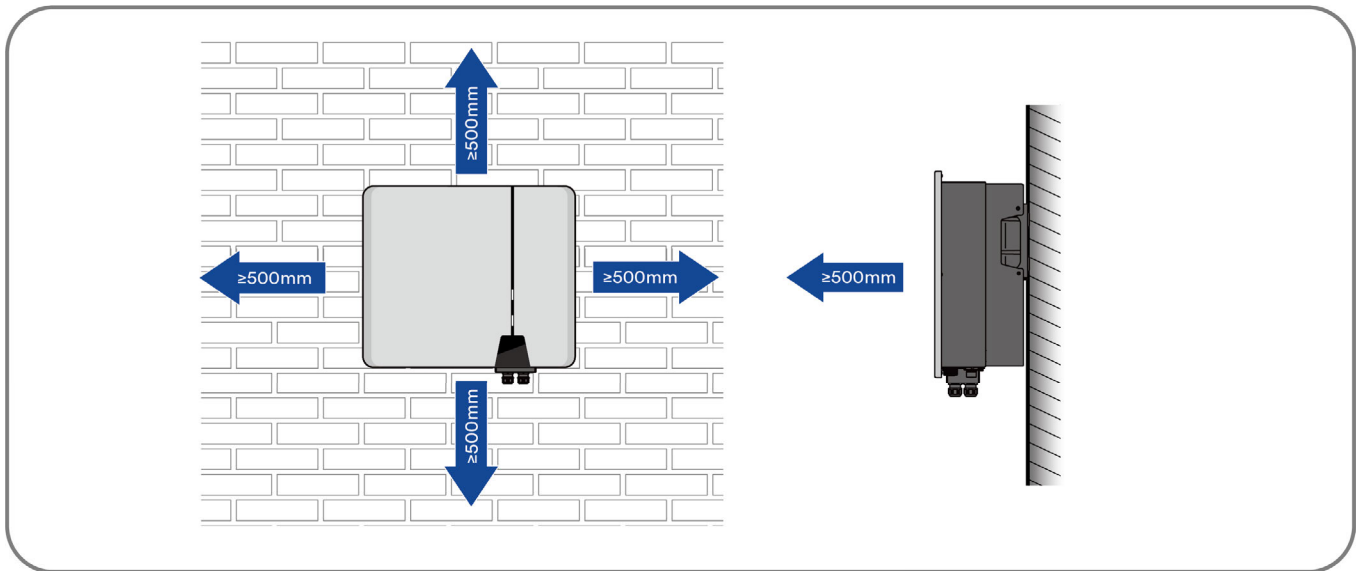

- In case of multiple inverters, reserve specific clearance between the inverters.

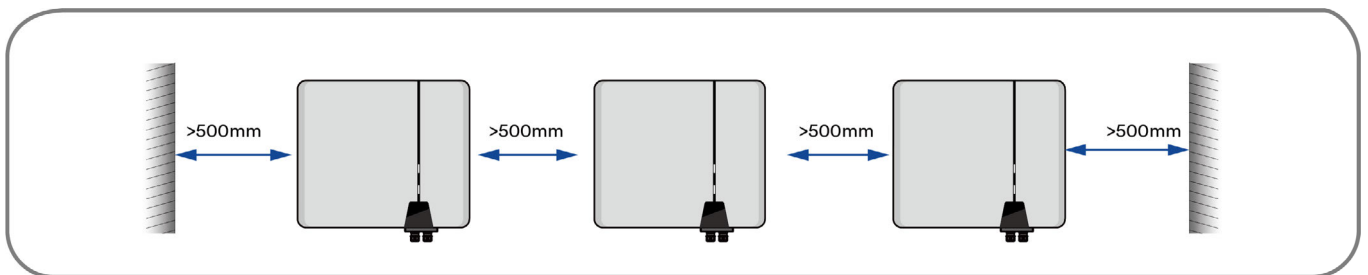

The product should be mounted such that the LED signals can be recognised and read without difficulty.

The DC switch of the product must always be freely accessible.

5.2 Taking out and moving the product

Open the inverter carton, take the inverter out of the packaging and place at the designated installation location.

⚠ CAUTION

Risk of injury due to the weight of the product!

The net weight of this product is over 26 kg. If the inverter is lifted incorrectly during the installation, it may fall down and cause injury or result in equipment damage.

- Transport and lift the product carefully. Take the weight of the product into account.
- Wear suitable personal protective equipment for all work on the product.

5.3 Mounting

Step 1: Align the mounting-bracket horizontally on the wall with the arrow upwards. Mark the position of the drill hole. Set the wall mounting bracket aside and drill the marked holes with a diameter of 10mm. The depth of the holes should be approximately 70 mm. Maintain the hammer drill bit perpendicular to the wall to avoid drilling at an incline.

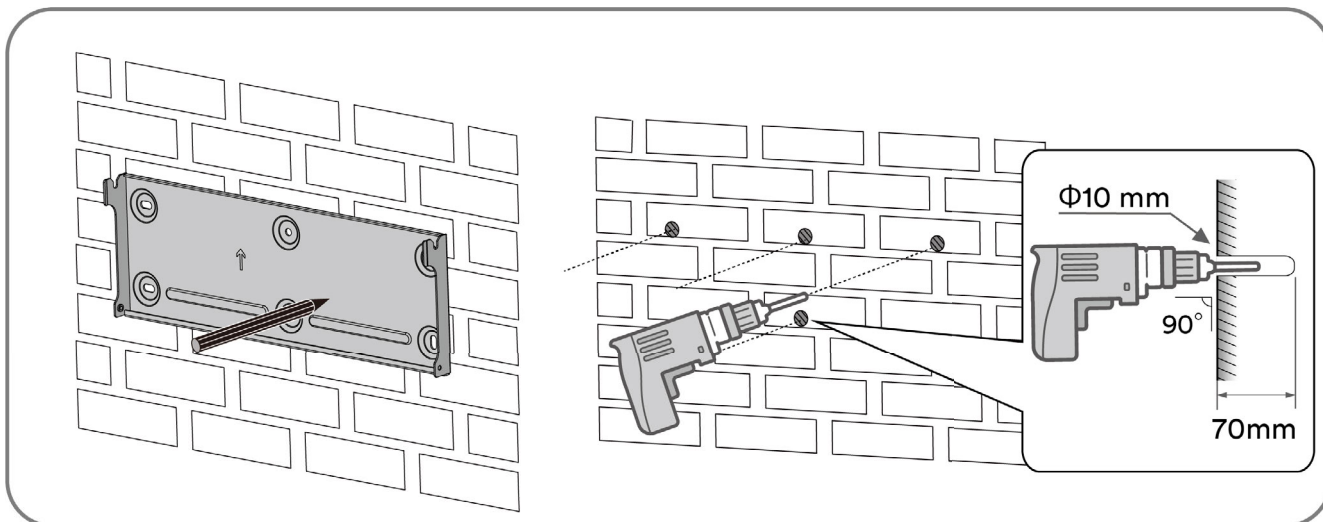

Step 2: Gently hammer the plastic wall plugs into the drilled hole.

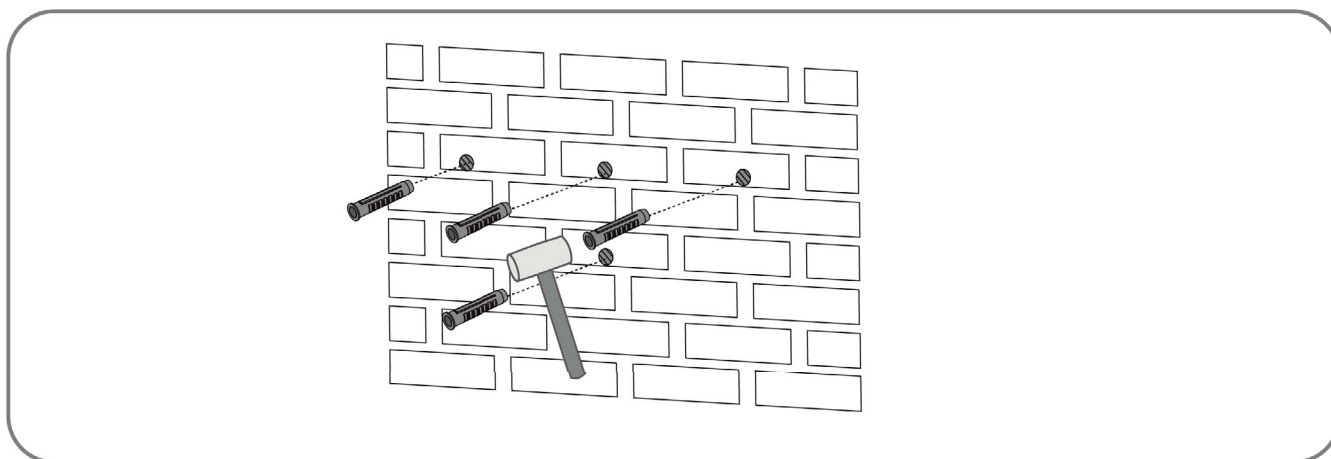

Step 3: Align the mounting-bracket with the hole positions and use the supplied screws to secure the mounting bracket onto the wall.

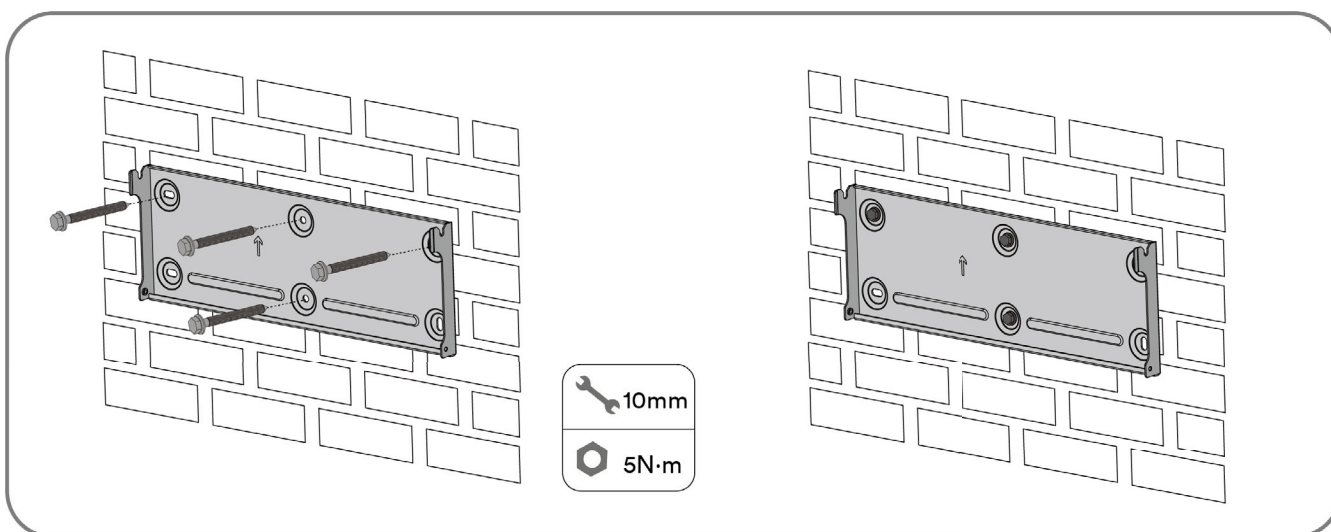

Step 4: Lift and hang the inverter onto the mounting-bracket and ensure that the mounting flanges fit securely into the mounting-bracket.

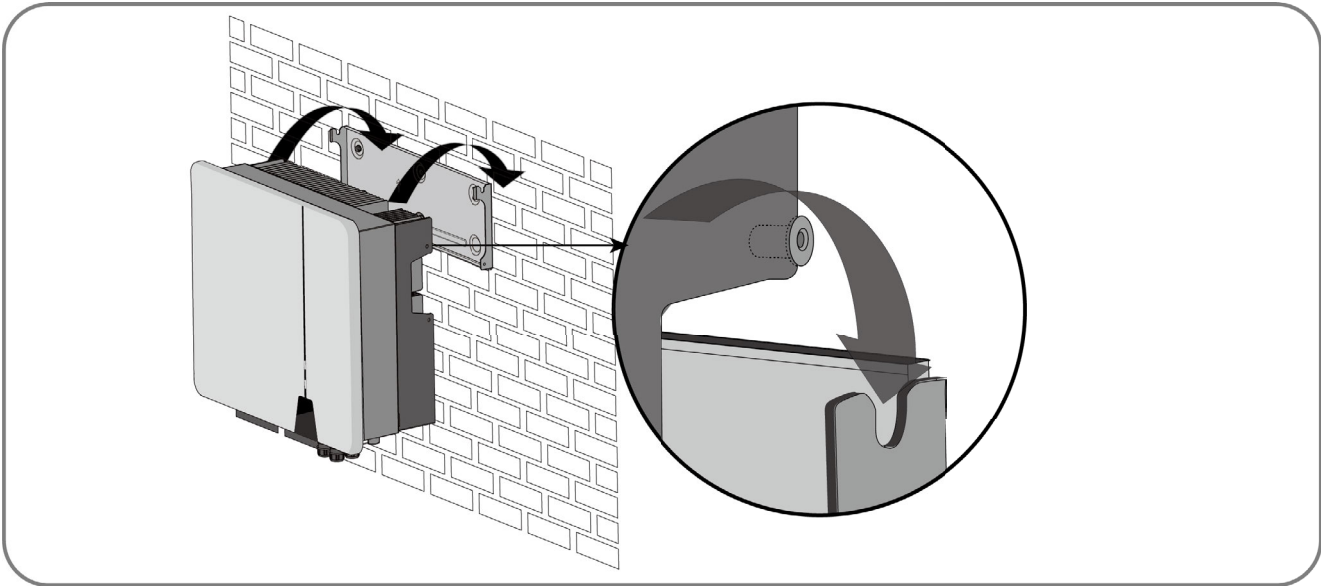

Step 5: Fix the inverter with screws.

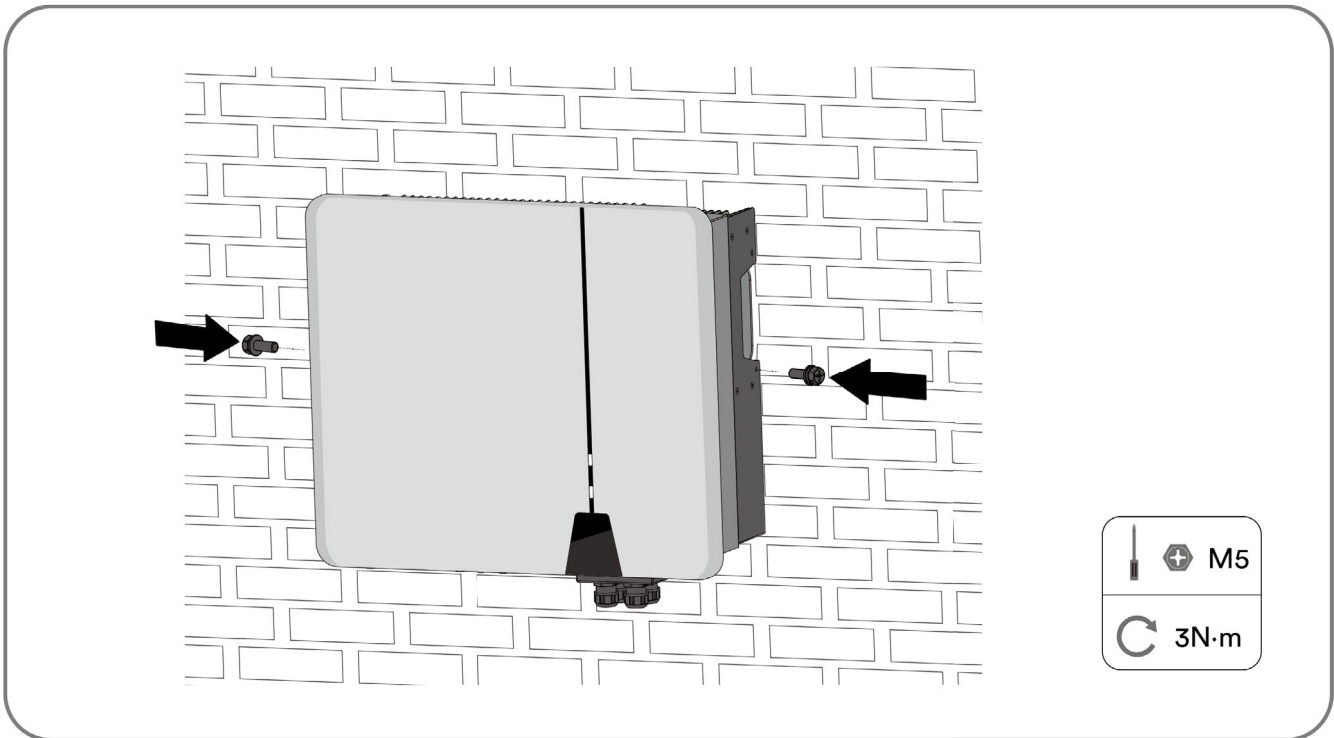

Installation complete.

6 Electrical connection

6.1 Connection Interface description

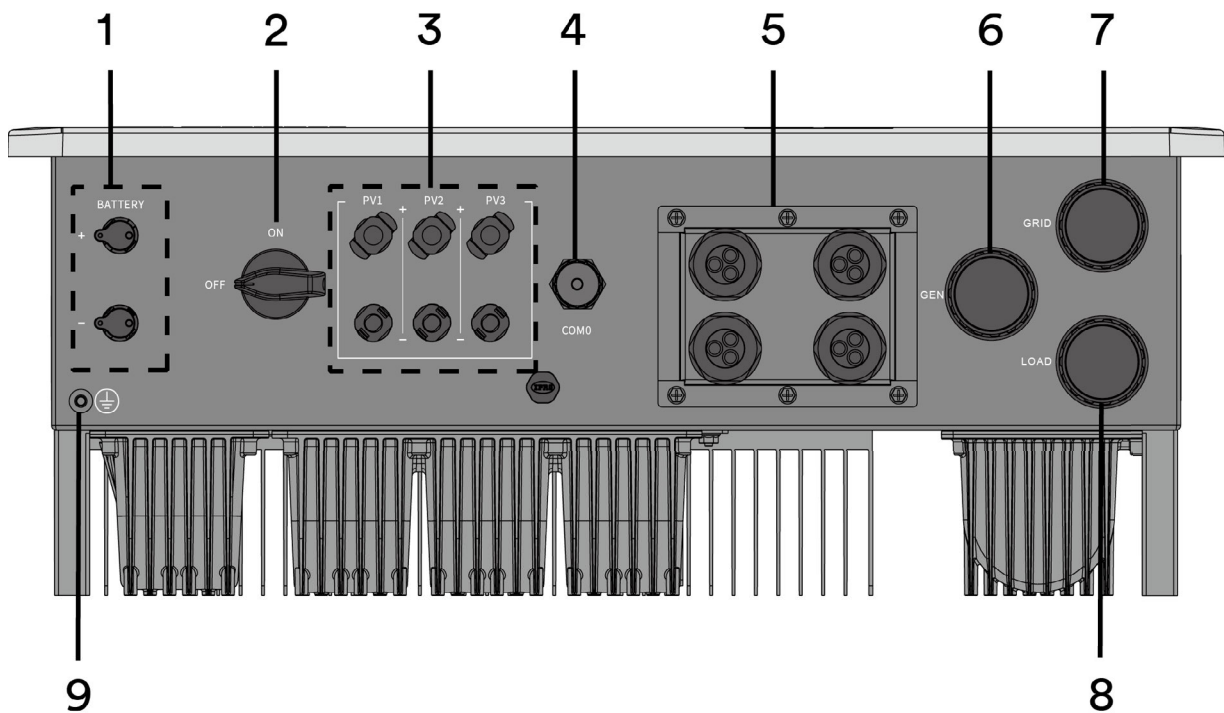

Figure shown here is for reference only. The actual product received may differ!

Object	Description
1	Battery connection terminals
2	DC-switch
3	PV Input
4	Ai-Dongle connector
5	Communication interface
6	GEN connector
7	AC connector
8	EPS Load connector
9	Additional grounding screw

6.2 Connecting additional grounding

The inverter is equipped with a residual current monitoring unit (RCMU). The RCMU monitoring device detects when there is no grounding conductor connected and disconnects the inverter from the utility grid if this is the case. Hence the product does not require an additional grounding or equipotential bonding when operating.

If the grounding conductor monitoring function is deactivated or the additional grounding is required by locally standard, you can connect additional grounding to the inverter.

Requirements for the secondary protection ground cable:

Item	Description	Note
1	Screw	M5, supplied
2	OT/DT terminal	M5, supplied
3	Yellow and green ground cable	Same as the PE wire in the AC cable.

Procedure:

Step 1: Strip the grounding cable insulation. Insert the stripped part of the grounding cable into the ring terminal lug and crimp using a crimping tool.

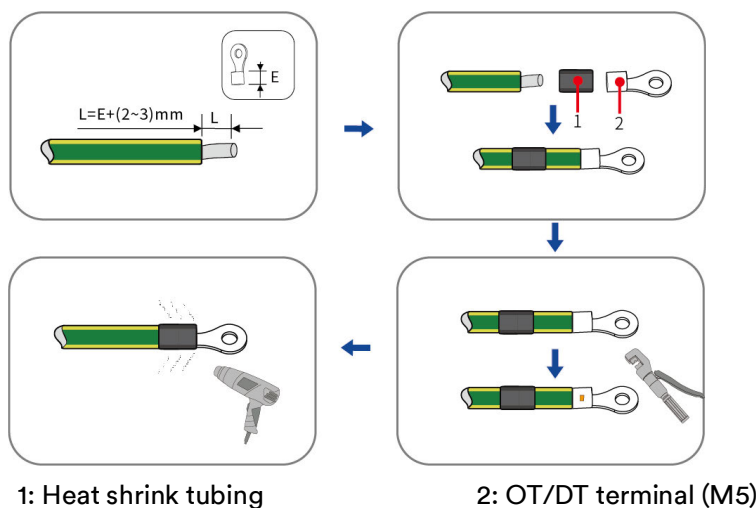

Step 2: Remove the screw on the ground terminal, insert the screw through the OT/DT terminal, and lock the terminal using a wrench.

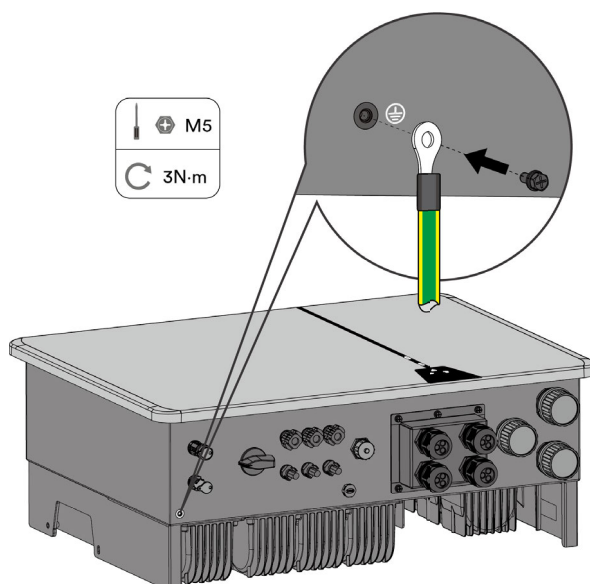

Step 3: Apply paint to the grounding terminal to ensure corrosion resistance.

Installation Complete.

6.3 Grid cable connection

6.3.1 Requirements for the Grid connection

Cable Requirements

The cable must be dimensioned in accordance with the local and national directives for the dimensioning of cables. The requirements for the minimum wire size derive from these directives. Examples of factors influencing cable dimensioning are: nominal AC current, type of cable, routing method, cable bundling, ambient temperature and maximum desired line losses.

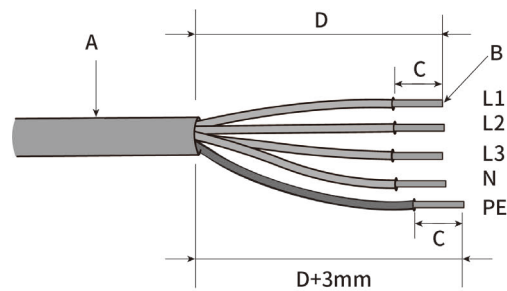

Item	Description	Value
A	External diameter	12.5...17.5 mm
B	Copper cable conductor cross-section	4~10 mm ²
C	Insulation stripping length	10 mm
D	Sheath stripping length	40 mm

Residual current protection

The product is equipped with an integrated universal current-sensitive residual current monitoring unit inside. Hence the product does not require an external residual-current device when operating.



If local regulations require the use of a residual-current device, please install a type A residual-current protection device with a protection limit of not less than 300 mA.

Overvoltage category

The inverter can be used in grids of overvoltage category III or lower in accordance with IEC 60664-1. That means that the product can be permanently connected to the grid-connection point of a building. In case of installations with long outdoor cable route, additional measures to reduce overvoltage category IV to overvoltage category III are required.

AC circuit breaker

In PV systems with multiple inverters, protect each inverter with a separate circuit breaker. This will prevent residual voltage being present at the corresponding cable after disconnection.

No consumer load should be applied between AC circuit breaker and the inverter.

The selection of the AC circuit breaker rating is dependent on the wiring design (wire cross-section area), cable type, wiring method, ambient temperature, inverter current rating, etc. Derating of the AC circuit breaker rating may be necessary due to

self-heating or if exposed to heat.

The maximum output current and the maximum output overcurrent protection of the inverters can be found in section 10 “Technical data”.

Grounding conductor monitoring

The inverter is equipped with a grounding conductor monitoring device. This grounding conductor monitoring device detects when there is no grounding conductor connected and disconnects the inverter from the utility grid if this is the case. Depending on the installation site and grid configuration, it may be advisable to deactivate the grounding conductor monitoring. This is necessary, for example, in an IT system if there is no neutral conductor present and you intend to install the inverter between two line conductors. If you are uncertain about this, contact your grid operator or Solplanet.



Safety in accordance with IEC 62109 when the grounding conductor monitoring is deactivated.

In order to guarantee safety in accordance with IEC 62109 when the grounding conductor monitoring is deactivated, carry out the following measure.

- Connect additional grounding that has at least the same cross-section as the connected grounding conductor to the AC cable. This prevents touch current in the event of the grounding conductor on the AC cable failing.

6.3.2 Assembling the grid connectors

Step 1: Switch off the miniature circuit-breaker or the switch of all energy sources and secure it against being inadvertently switched back on.

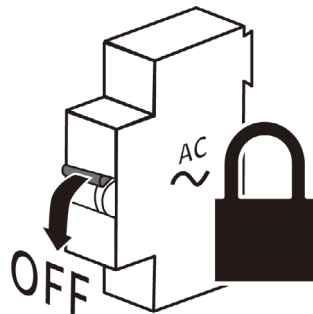

Step 2: Separate the AC grid connector.

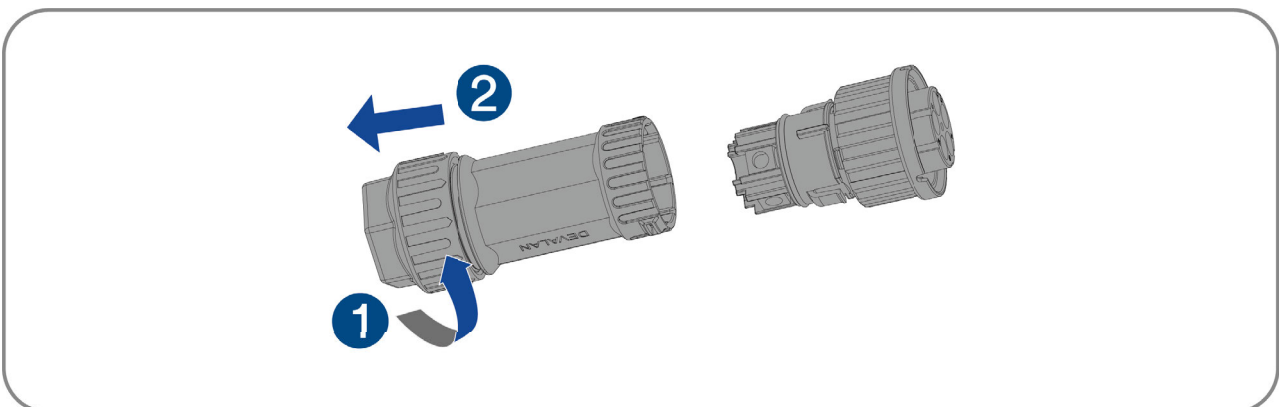

Step 3: Crimp the AC cable (when using multi-strand cable) with bootlace ferrules using appropriate crimping tools.

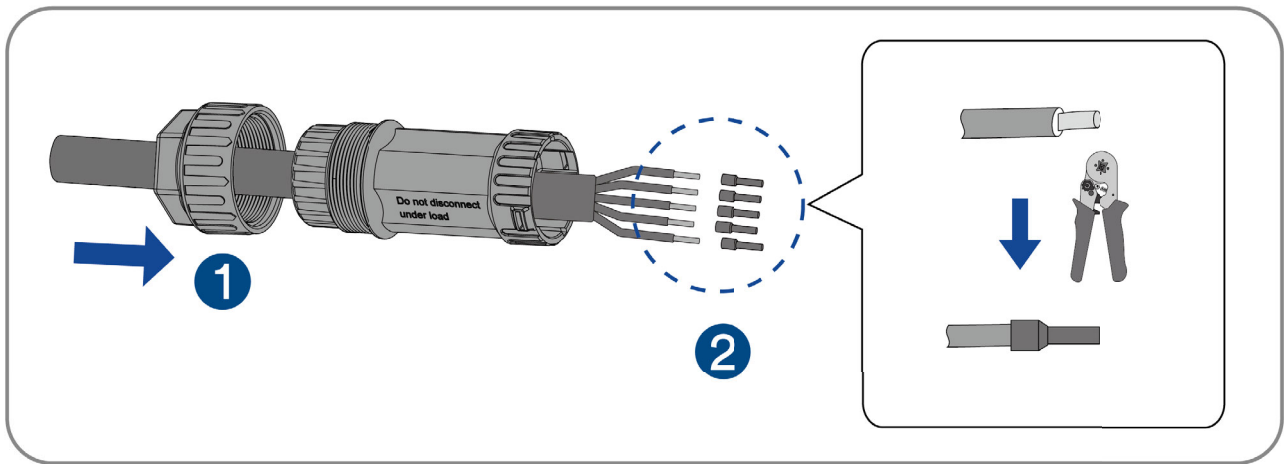

Crimping tool selection and crimping requirements are shown in the following figure:

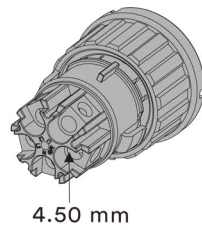

4 mm ²	6 mm ²	4 mm ²	4 mm ²	6 mm ²	4 mm ²
↓	↓	↓	↓	↓	↓
4.5 mm	4.09 mm	3.38 mm	3.64 mm	3.92 mm	3.10 mm
✗	✓	✓	✓	✓	✓

Step 4: Insert the cables into the terminal holes in turn according to the phase sequence marked on the pipe head, and then lock each cable with the terminal using a hexagonal screwdriver and screw the torque 1.2+/-0.1N·m..

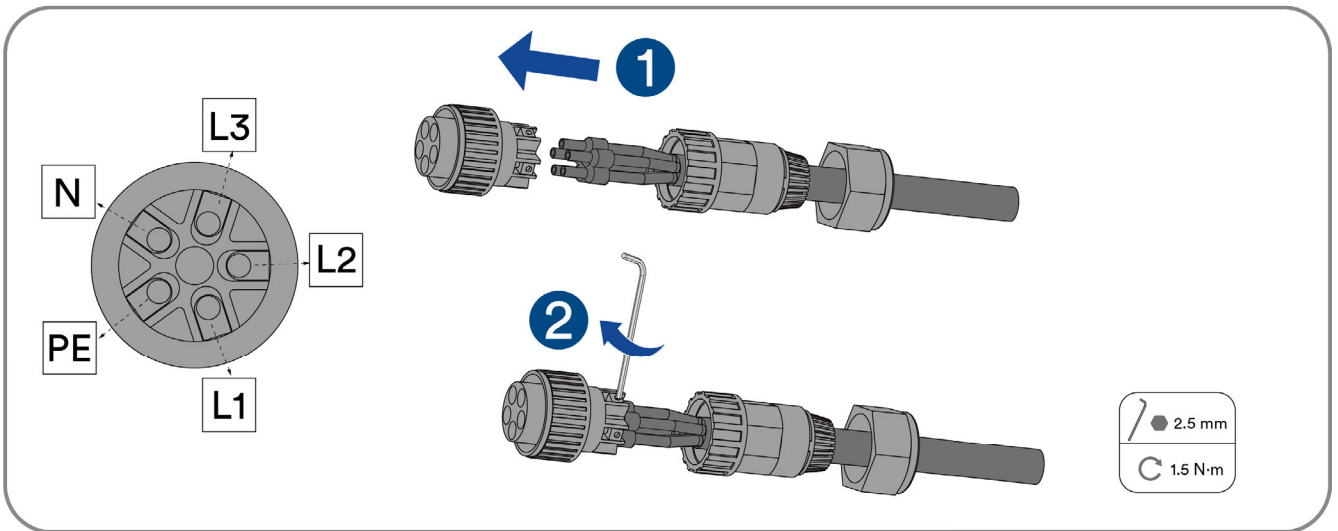

Step 5: Insert the main body into the terminal hear clasp and a “click” sound should be heard when done correctly.

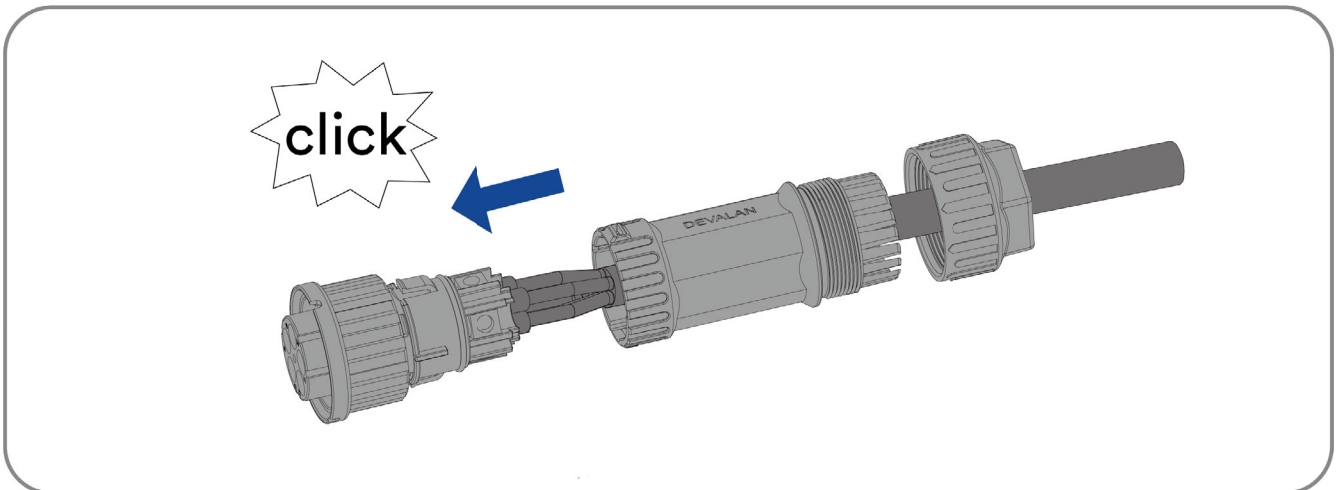

Step 6: Tighten the nut with an open-ended wrench (torque 2.5 ± 0.5 N·m).

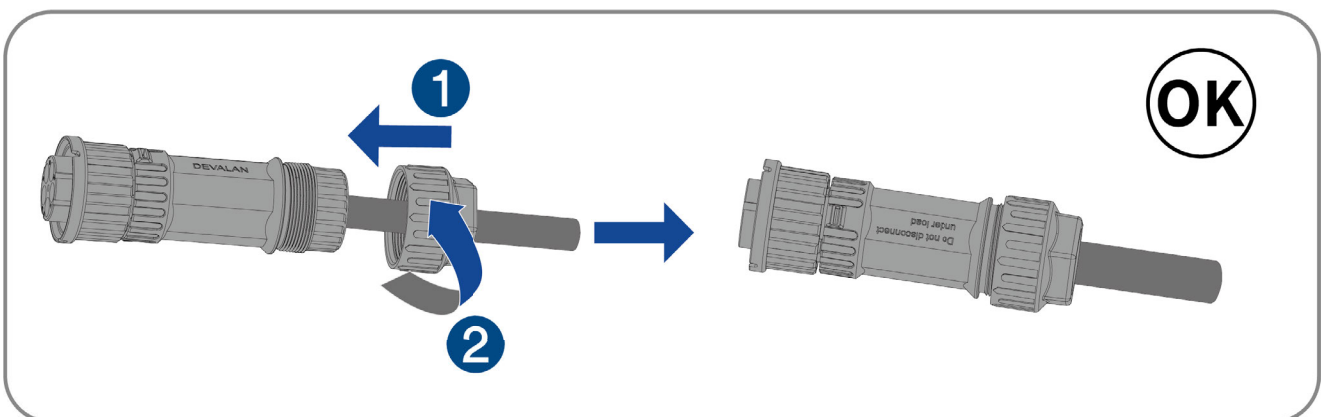

6.3.3. Connecting the grid connector

Step 1: Remove the dust cover.

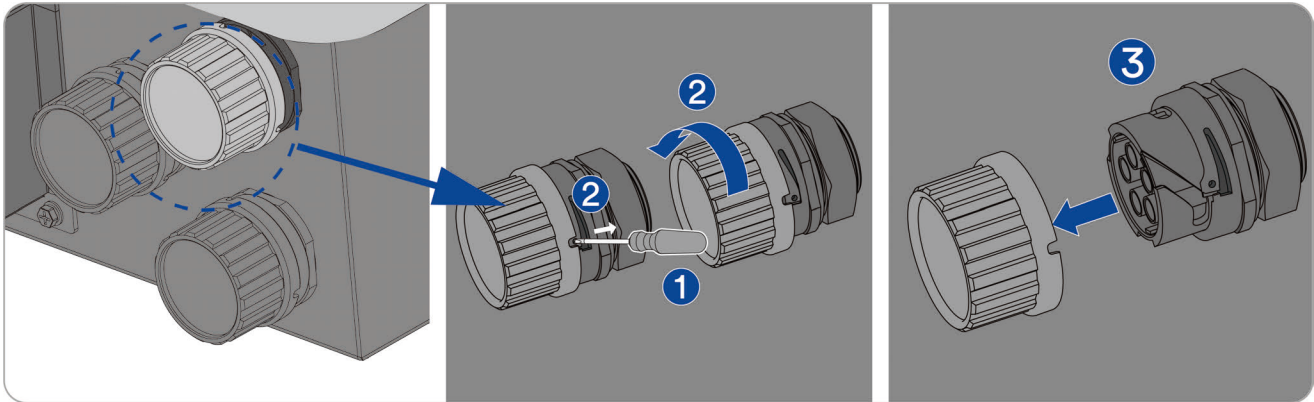

Step 2: Connect the AC plug into the connector, a “click” sound should be heard when done correctly..

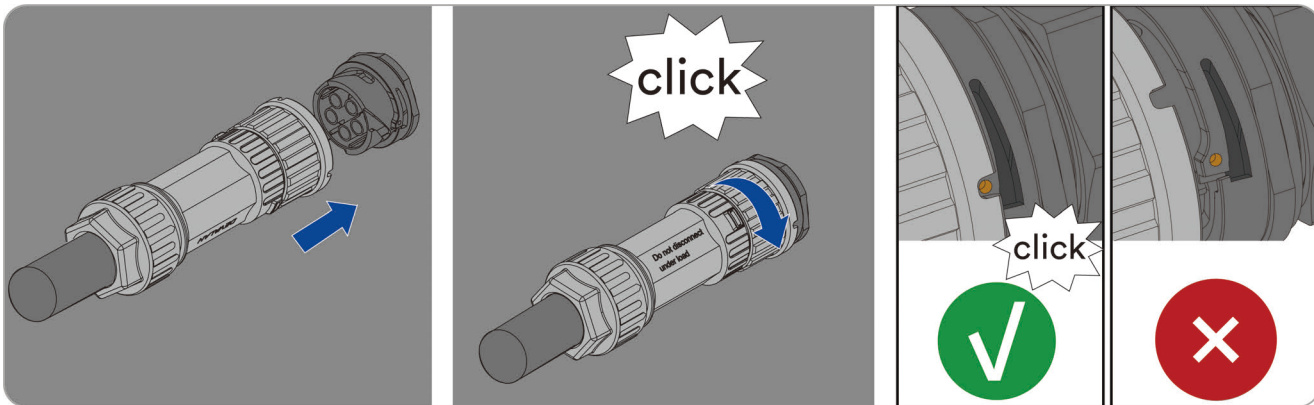

Complete the installation.

6.4 EPS Load cable connection

6.4.1 Requirements for the EPS Load connection

For EPS Load connection requirements, refer to “6.3.1 Grid Connection Requirements” for details.

6.4.2. Assembling the EPS Load connectors

Step 1: Switch off the miniature circuit-breaker or the switch of every energy sources and secure it against being inadvertently switched back on.

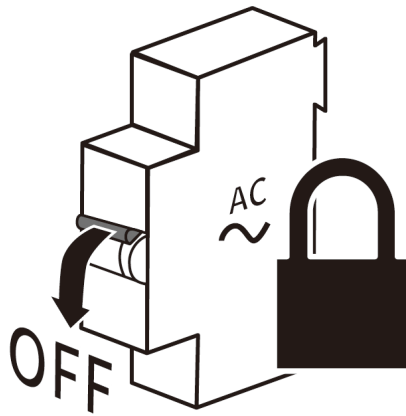

Step 2: Separate the EPS load connector.

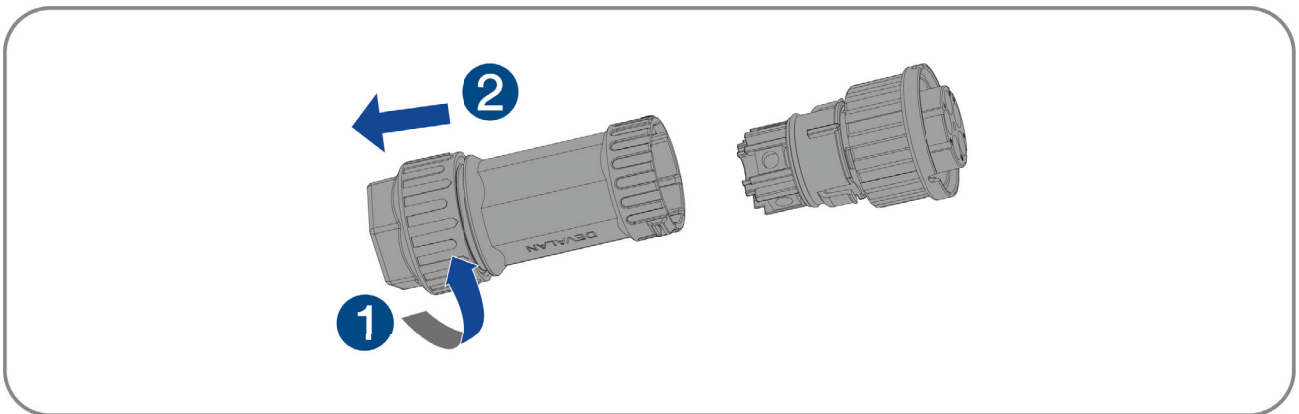

Step 3: Crimp the AC cable (when using multi-strand cable) with bootlace ferrules using appropriate crimping tools.

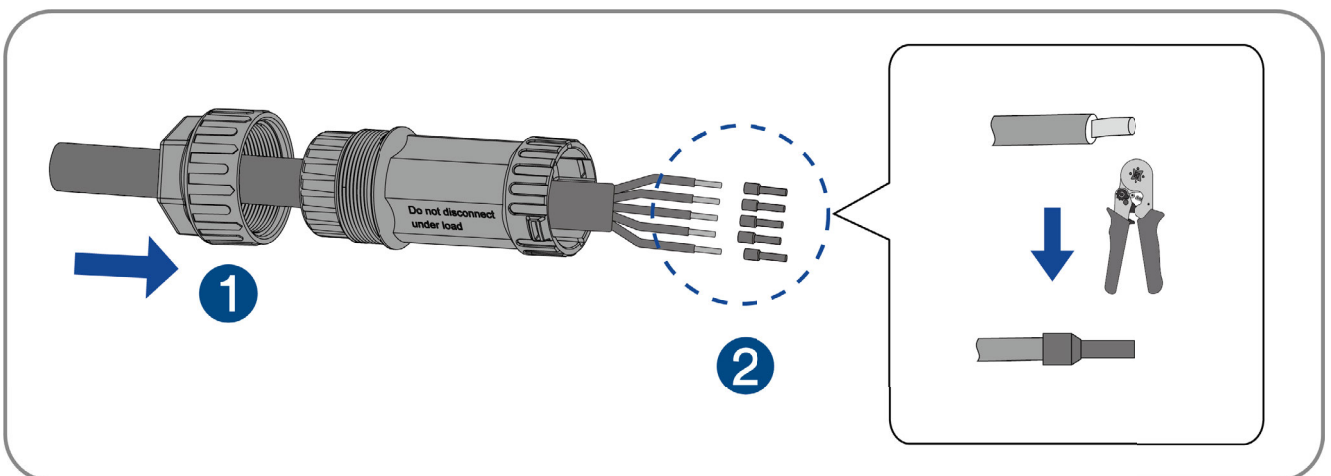

Crimping tool selection and crimping requirements are shown in the following figure:

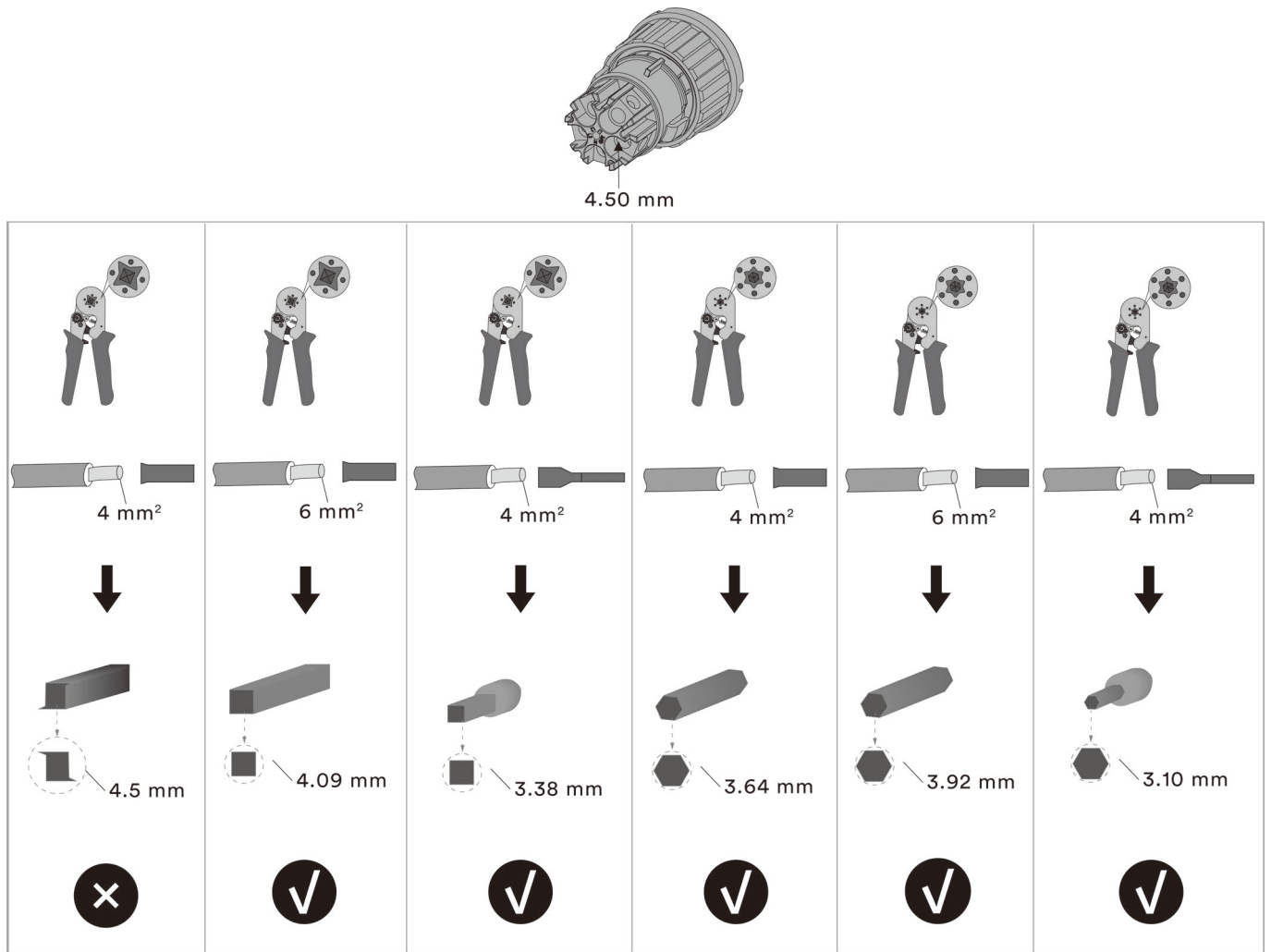

Step 4: Insert the cables into the terminal holes in turn according to the phase sequence marked on the pipe head, and then lock each cable with the terminal using a hexagonal screwdriver and screw the torque 1.2+/-0.1N·m.

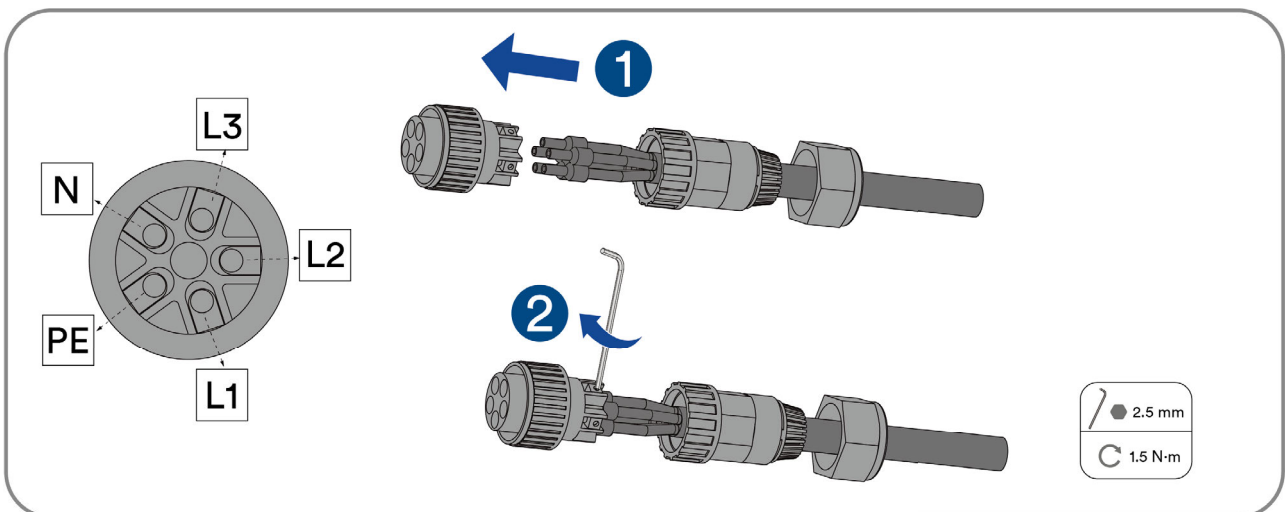

Step 5: Insert the main body into the terminal hear clasp and a “click” sound should be heard when done correctly.

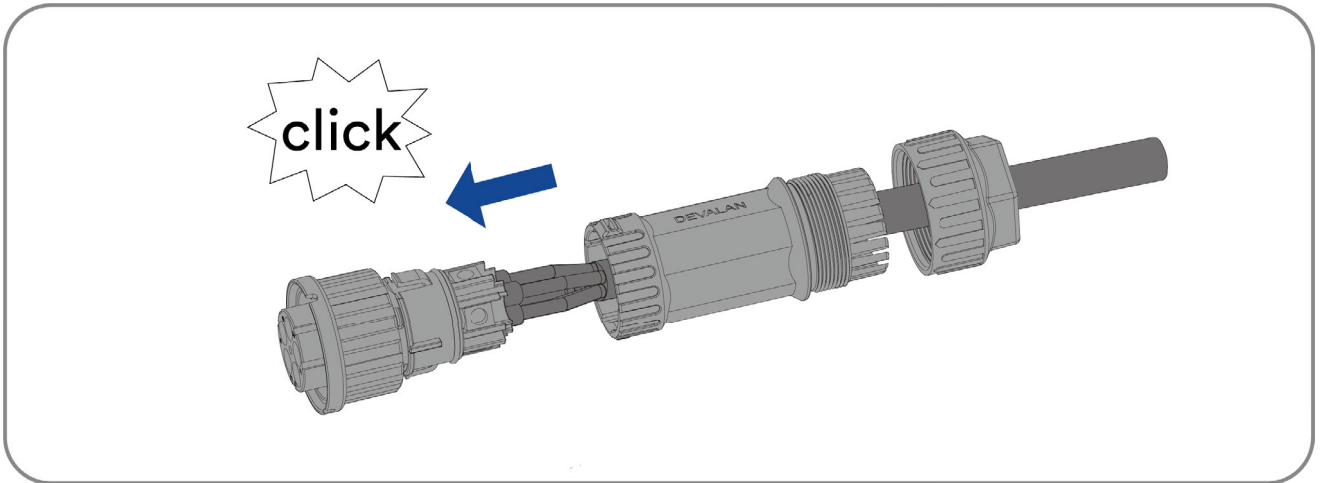

Step 6: Tighten the nut with an open-ended wrench (torque $2.5 \pm 0.5 \text{N}\cdot\text{m}$).

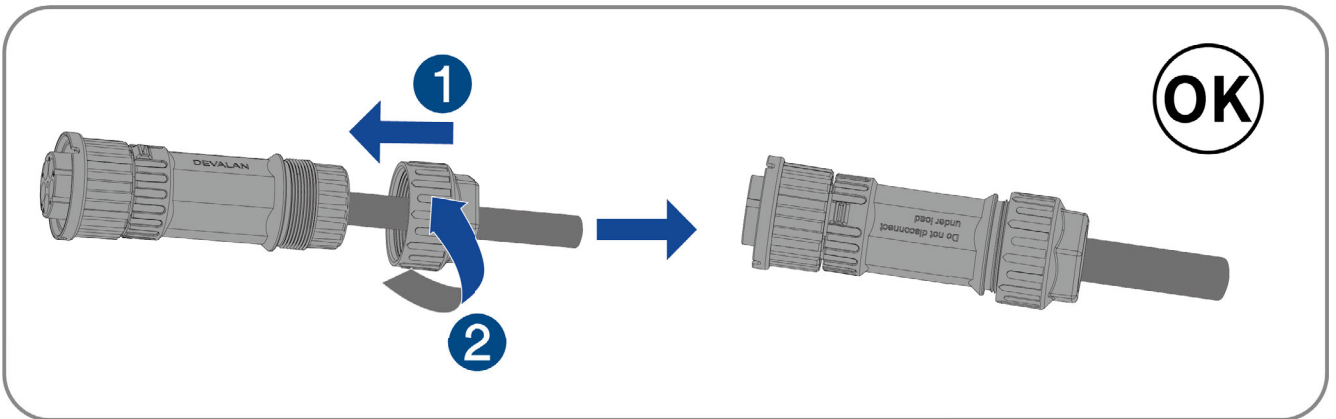

6.4.3 Connecting the EPS Load connectors

Step 1: Remove the dust cover.

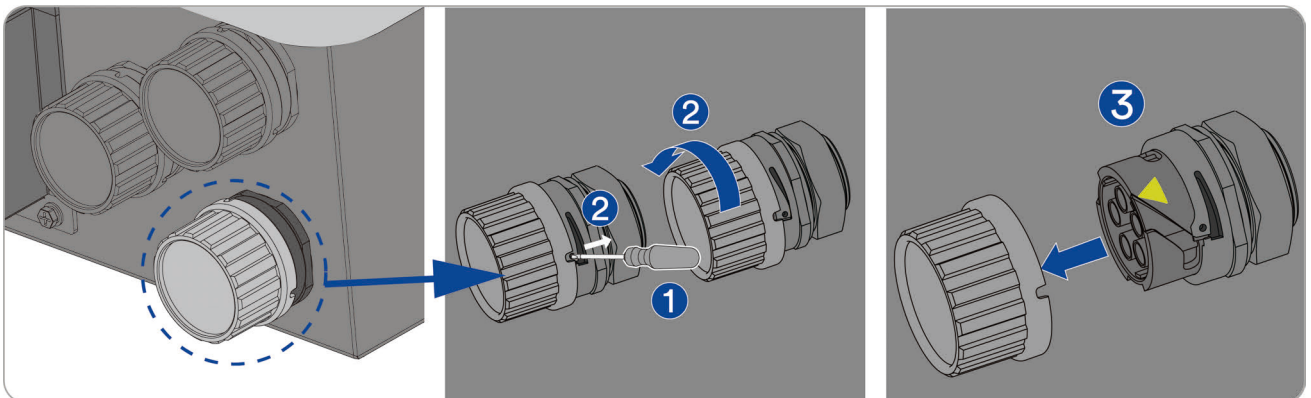

Step 2: The installation arrow indicates insertion the female connector, and hear the “click”

sound.

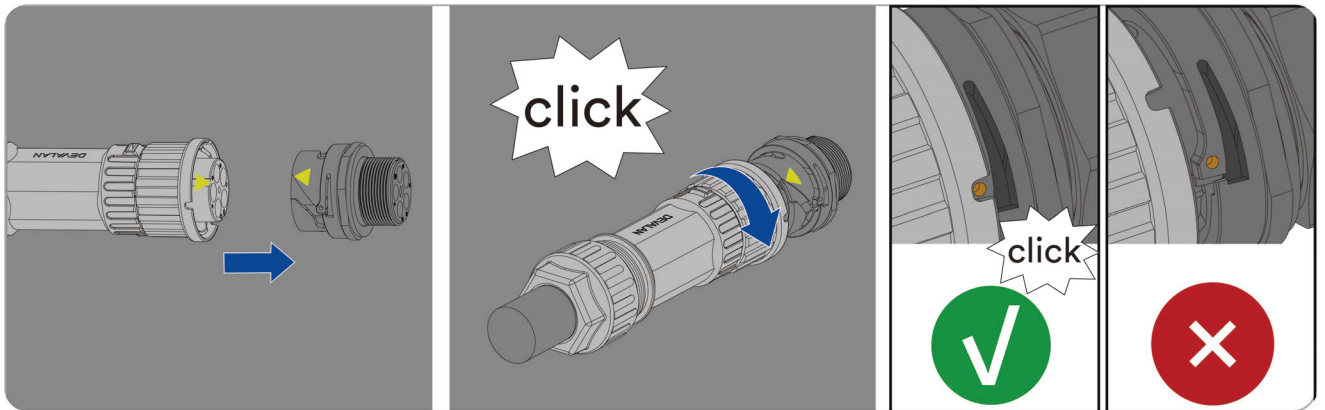

Complete the installation.

6.5 Generator cable connection

6.5.1 Requirements for the generator cable connection

For generator cable connection requirements, refer to “6.3.1 Grid Connection Requirements” for details.

6.5.2 Assembling the generator cable connectors

Step 1: Switch off the miniature circuit-breaker or the switch of every energy sources and secure it against being inadvertently switched back on.

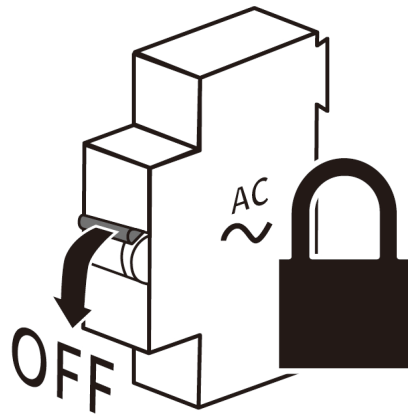

Step 2: separate the generator connector.

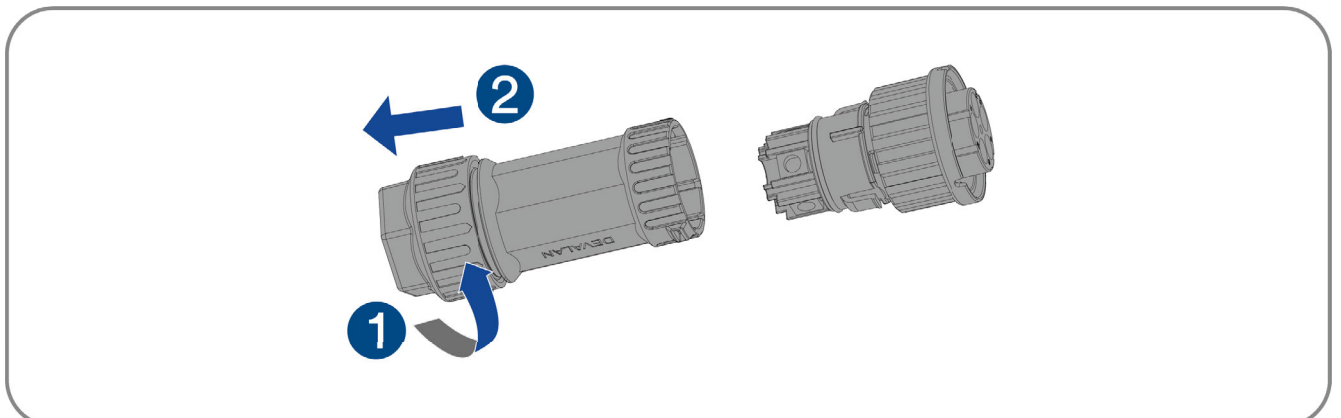

Step 3: Crimp the AC cable (when using multi-strand cable) with bootlace ferrules using appropriate crimping tools.

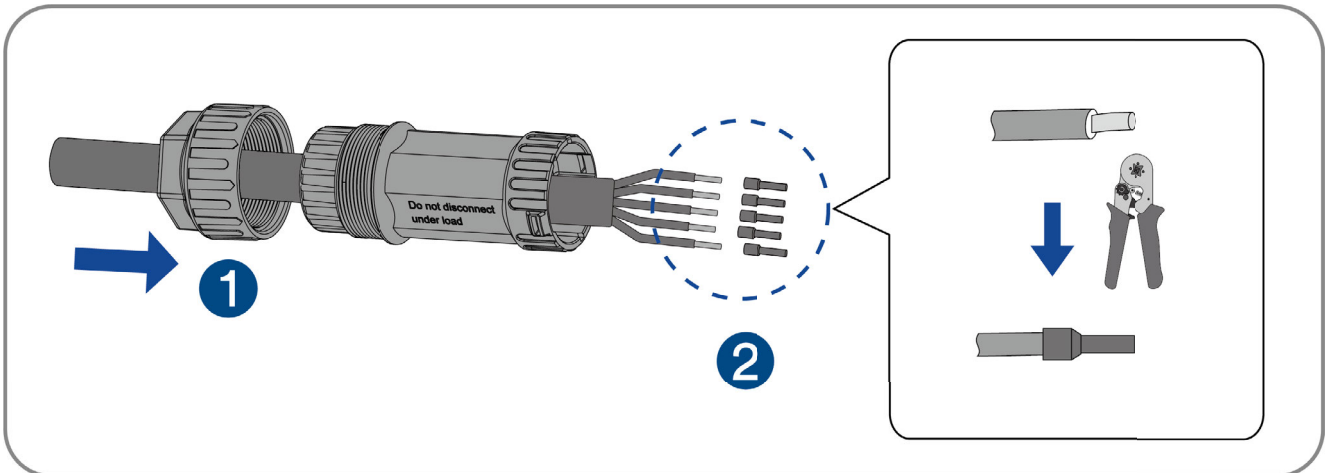

Crimping tool selection and crimping requirements are shown in the following figure:

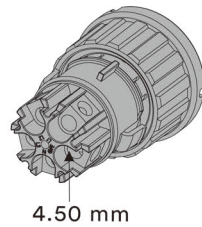

4 mm ²	6 mm ²	4 mm ²	4 mm ²	6 mm ²	4 mm ²
↓	↓	↓	↓	↓	↓
4.5 mm	4.09 mm	3.38 mm	3.64 mm	3.92 mm	3.10 mm
✗	✓	✓	✓	✓	✓

Step 4: Insert the cables into the terminal holes in turn according to the phase sequence marked on the pipe head, and then lock each cable with the terminal using a hexagonal screwdriver and screw the torque 1.2+/-0.1N·m.

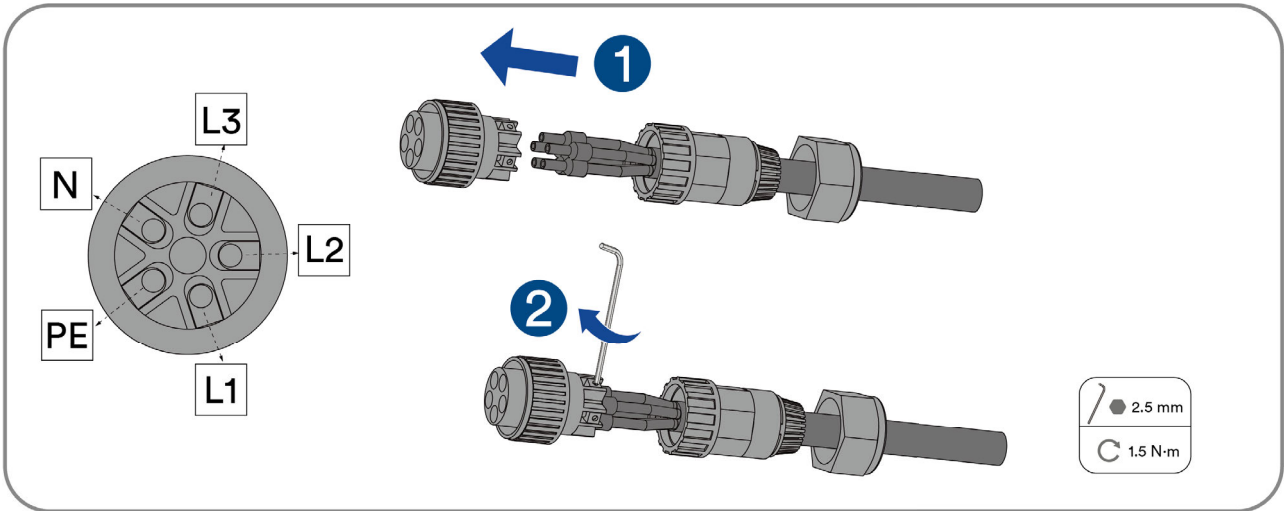

Step 5: Insert the main body into the terminal ear clasp and a “click” sound should be heard when done correctly.

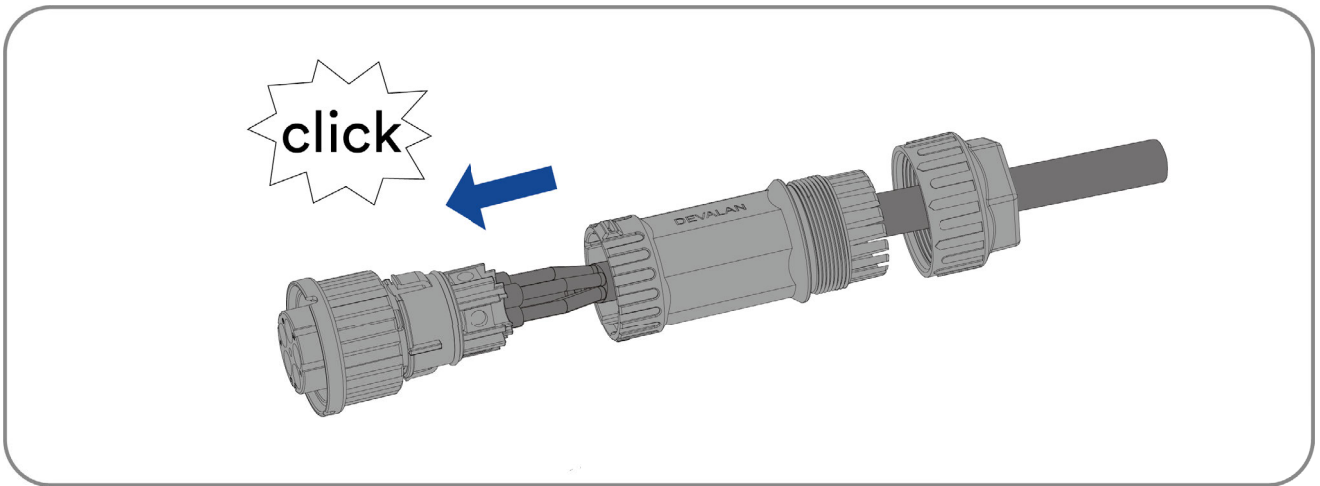

Step 6: Tighten the nut with an open-ended wrench (torque $2.5 \pm 0.5 \text{ N}\cdot\text{m}$).

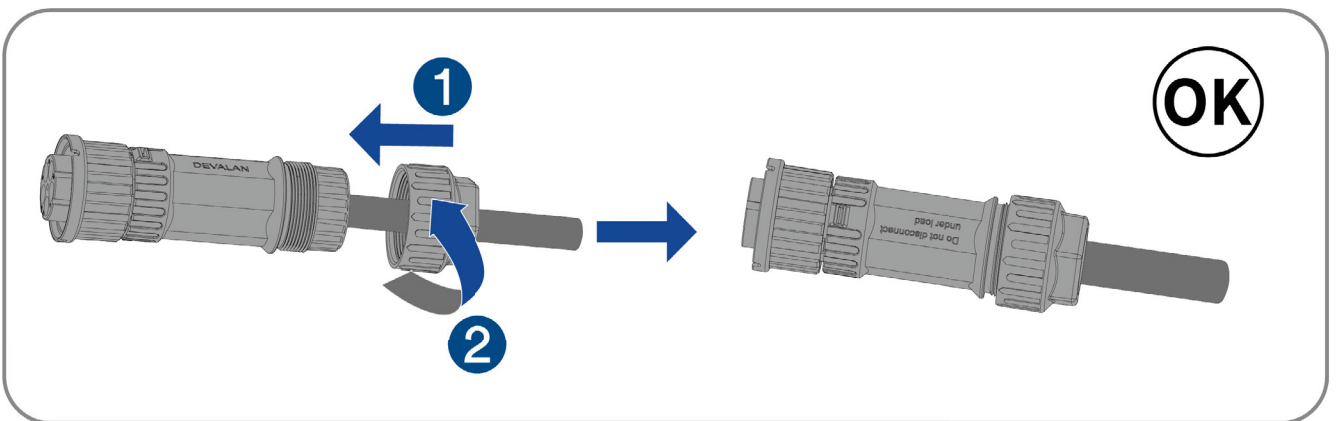

6.5.3. Connecting the generator cable connectors

Step 1: Remove the dust cover.

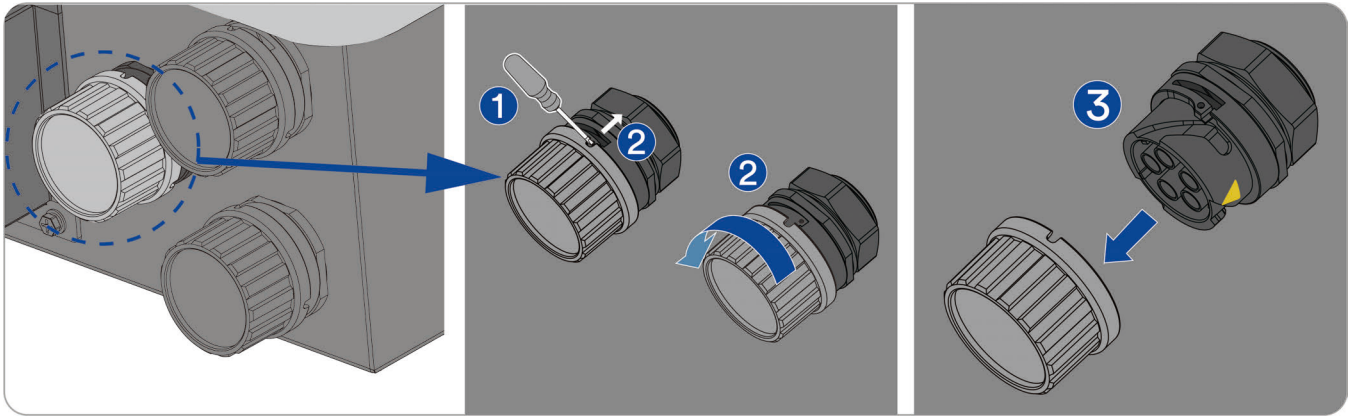

Step 2: The installation arrow indicates insertion the female connector, and hear the “click” sound.

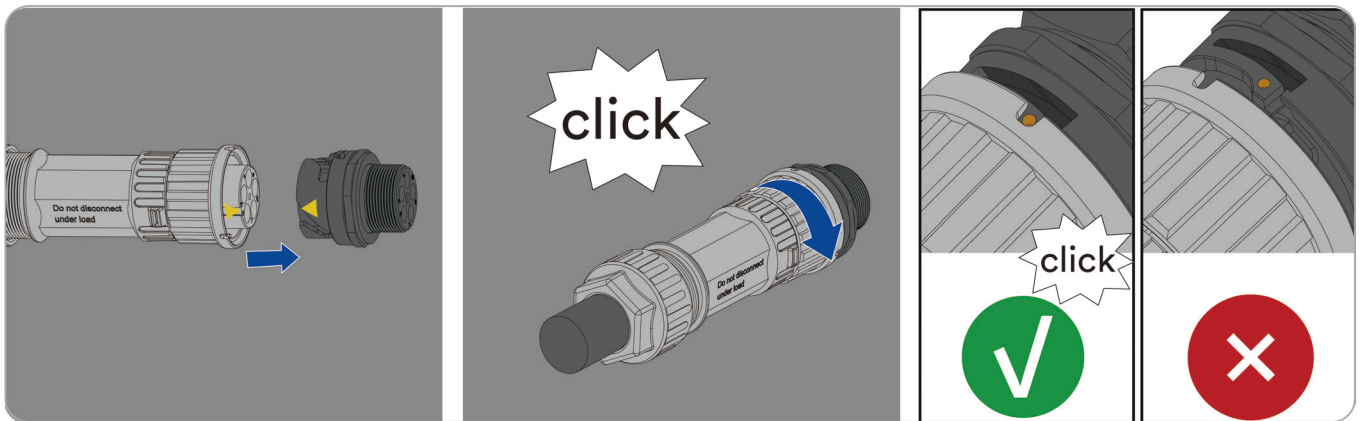

Complete the installation.

6.6 DC connection

6.6.1 Requirements for the DC connection

Requirements for the PV modules per input:

- All PV modules should be of the same type.
- All PV modules should be aligned and tilted identically.
- On the coldest day based on statistical records, the open-circuit voltage of the PV modules must never exceed the maximum input voltage of the inverter.
- The maximum input current per PV module must be maintained and must not exceed the through fault current of the DC connectors.
- The connection cables to the inverter must be equipped with the connectors included in the scope of delivery.
- The thresholds for the input voltage and the input current of the inverter must be adhered to.
- The positive connection cables of the PV modules must be equipped with the positive DC connectors. The negative connection cables of the PV modules must be equipped with the negative DC connectors.

6.6.2 Assembling the DC connectors

DANGER

Danger to life due to electric shock when live components or DC cables are touched !

When exposed to light, the PV modules generate high DC voltage which is present in the DC cables. Touching live DC cables results in death or lethal injuries due to electric shock.

- Do not touch non-insulated parts or cables.
- Disconnect the product from voltage sources and ensure it cannot be reconnected before working on the device.
- Wear suitable personal protective equipment for all work on the product.



For connection to the inverter, all PV module connection cable must be fitted with the DC connectors provided. There may be one of two different type DC connector shipped. Assemble the DC connectors as described in the following.

Type 1 DC connector:

Assemble the DC connectors as described below. Be sure to observe the correct polarity. The DC connectors are marked with the symbols “+” and “-”.

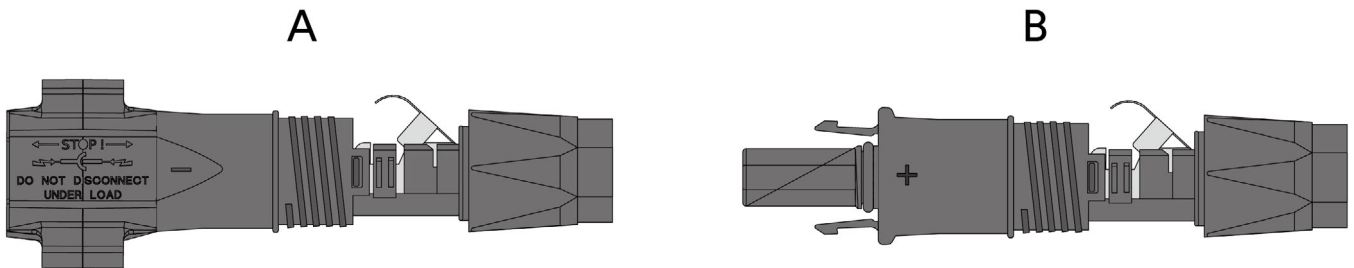

Cable requirements:

Item	Description	Value
1	Cable type	PV cable
2	External diameter	5-8 mm
3	Conductor cross-section	2.5-6 mm ²
4	Number of copper wires	At least 7
5	The rated voltage	≥1100v

Procedure:

Step 1: Strip 12 mm of cable insulation from the cable.

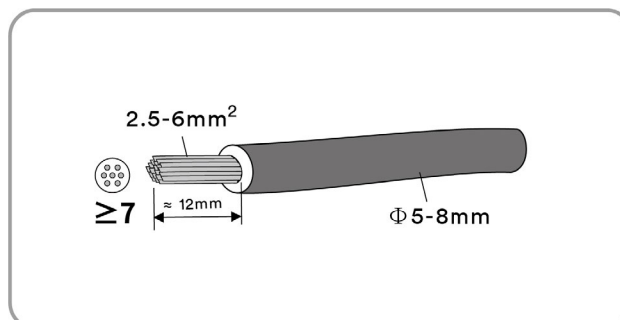

Step 2: Crimp the contacts with the corresponding cables and a “click” sound should be heard when done correctly.

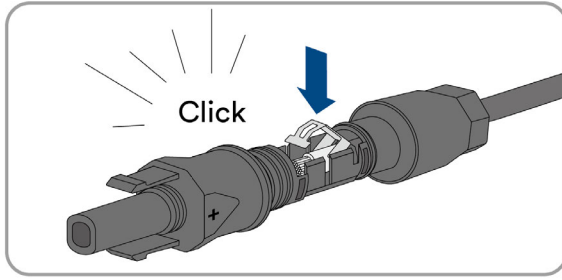
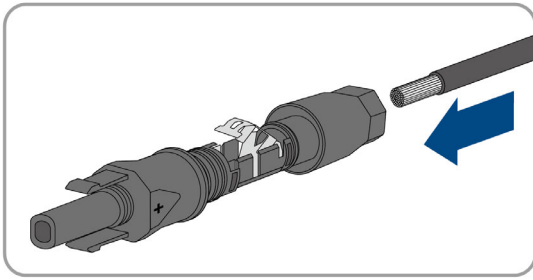

If the stranded wire is not visible in the chamber, the cable is not correctly inserted and the connector must be reassembled. To do this, the cable must be removed from the connector.

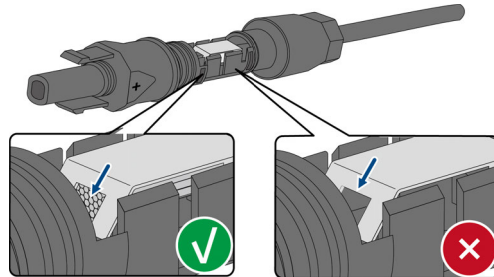

Release the clamping bracket. To do so, insert a screwdriver (blade width: 3.5mm) into the clamping bracket and pry the clamping bracket open.

Remove the cable and go back to step 2.

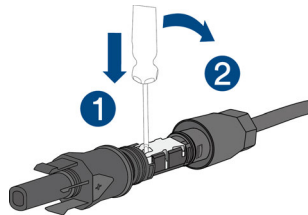

Step 3: Push the swivel nut up to the thread and tighten the swivel nut. (SW15, Torque: 2.0Nm)

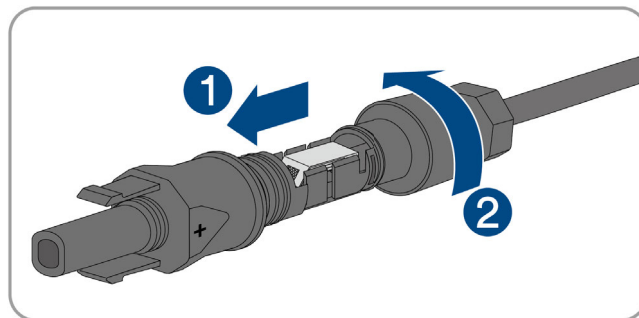

Type 2 DC connector:

Assemble the DC connectors as described in the following.

Assemble the DC connectors as described below. Be sure to observe the correct polarity. The DC connectors are marked with the symbols “+” and “-”.

A

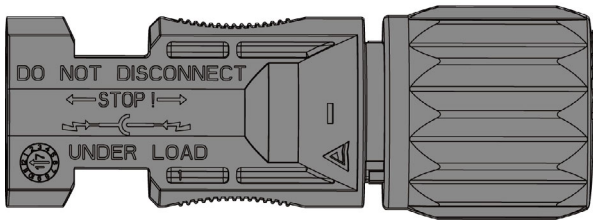

B

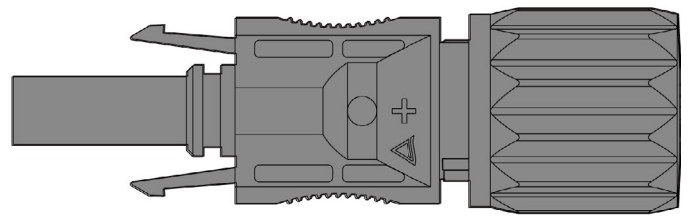

Cable requirements:

Item	Description	Value
1	Cable type	PV1-F, UL-ZKLA or USE2
2	External diameter	5-8 mm
3	Conductor cross-section	2.5-6 mm ²
4	Number of copper wires	At least 7
5	The rated voltage	≥1100v

Procedure:

Step 1: Strip 12 mm of cable insulation from the cable.

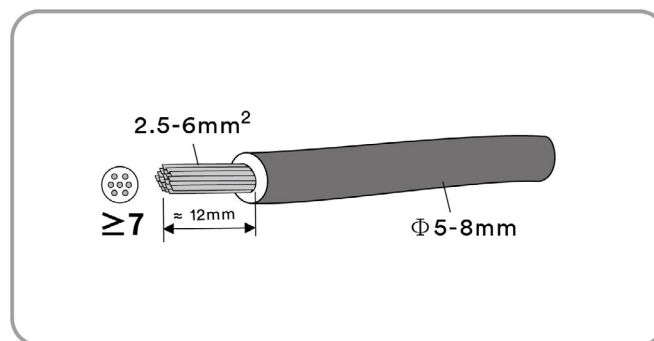

Step 2: Assemble the cable ends with the appropriate crimping tools..

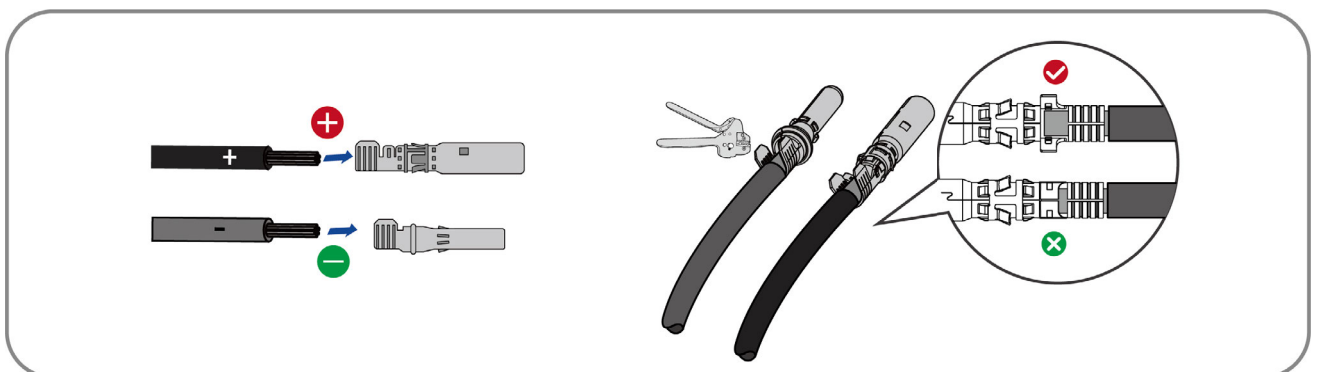

Step 3: Insert the cable through cable gland, and insert into the insulator until it snaps into place. Gently pull the cable backward to ensure firm connection. Tighten the cable gland and the insulator (Torque 2.5-3Nm).

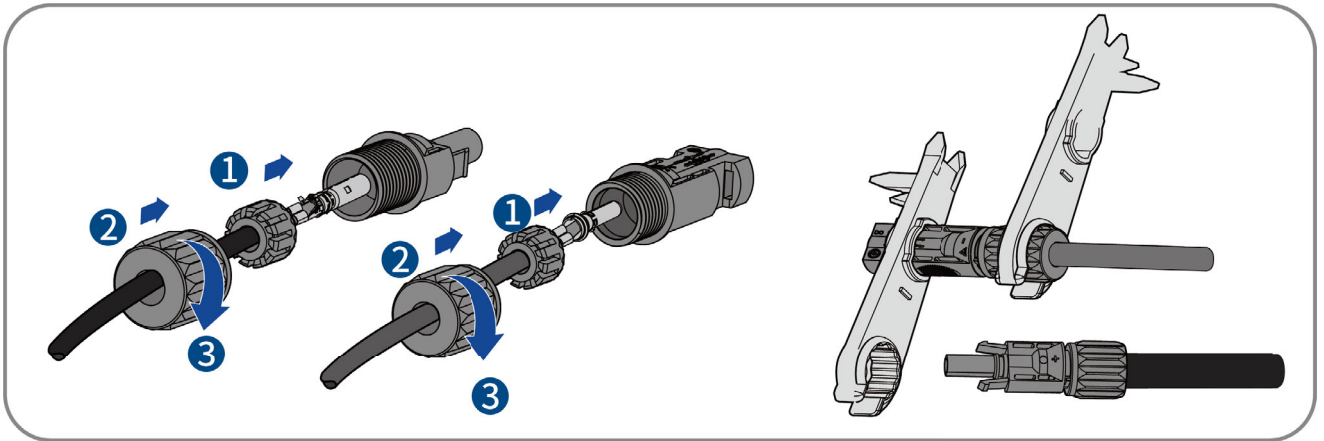

Step 4: Ensure that the cable is correctly positioned.

6.6.3 Connecting the PV module

DANGER

Danger to life due to high voltages in the inverter!

When exposed to light, the PV modules generate high DC voltage which is present in the DC cables. Touching live DC cables results in death or lethal injuries due to electric shock..

- Before connecting the PV array, ensure that the DC switch is switched off and that it cannot be reactivated.
- Do not disconnect the DC connectors under load.

NOTICE

The inverter can be destroyed by overvoltage!

If the voltage of the strings exceeds the maximum DC input voltage of the inverter, it can be destroyed due to overvoltage. All warranty claims become void.

- Do not connect strings with an open-circuit voltage greater than the maximum DC input voltage of the inverter.
- Check the design of the PV system.

Procedure:

Step 1: Ensure that the DC switch is switched off and ensure that it cannot be accidentally reconnected.

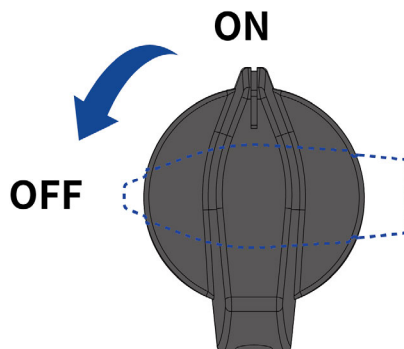

Step 2: Ensure that the DC switch is switched off and ensure that it cannot be accidentally reconnected.

Step 3: Ensure that there is no ground fault in the PV array.

Step 4: Check whether the DC connector has the correct polarity.

If the DC connector is equipped with a DC cable having the wrong polarity, the DC connector must be reassembled. The

DC cable must always have the same polarity as the DC connector.

Step 5: Ensure that the open-circuit voltage of the PV array does not exceed the maximum DC input voltage of the inverter.

Step 6: Connect the assembled DC connectors to the inverter until they audibly snap into place.

NOTICE

Do not operate the DC switch during the operation of the inverter, otherwise it will cause the inverter to stop or even damage the inverter.

Type 1 DC connector:

- Connect the assembled DC connectors to the inverter.

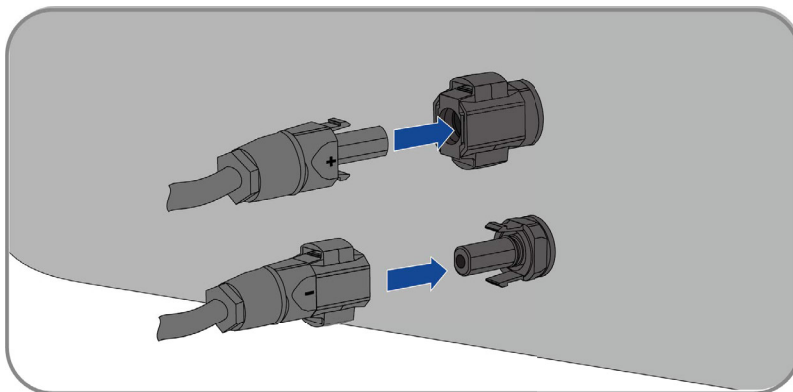

- For unused DC connectors, push down the clamping bracket and push the swivel nut up to the thread. Insert the DC connectors with sealing plugs into the corresponding DC inputs on the inverter.

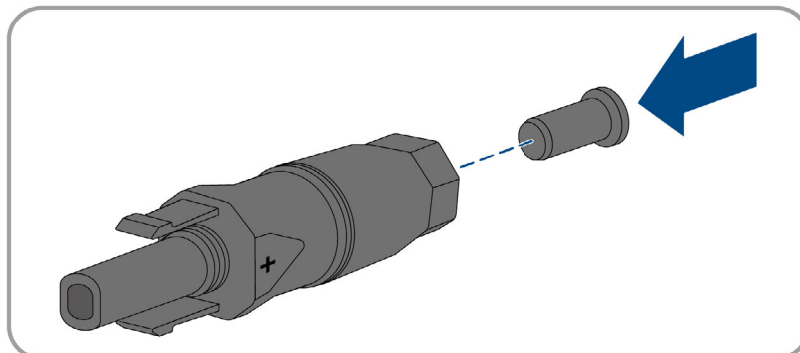
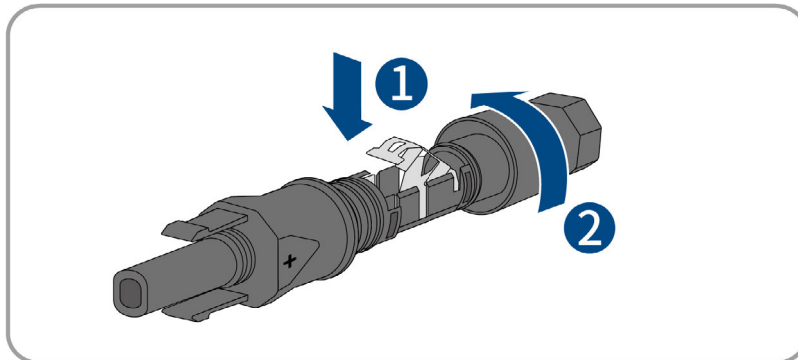

- Insert the DC connectors with sealing plugs into the corresponding DC inputs on the inverter.

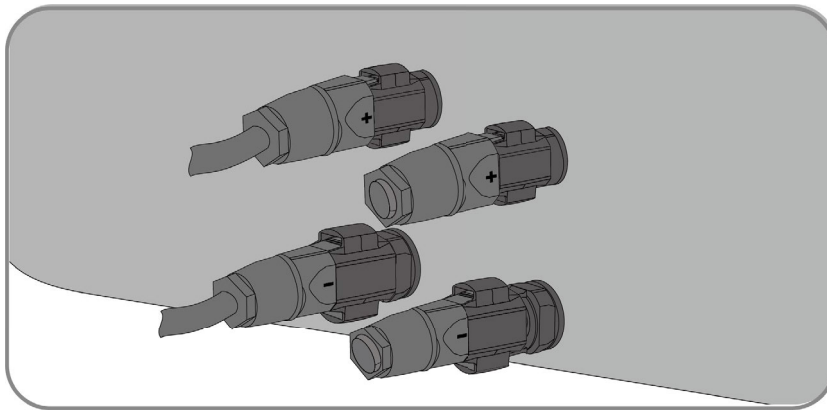

Type 2 DC connector:

- Connect the assembled DC connectors to the inverter.

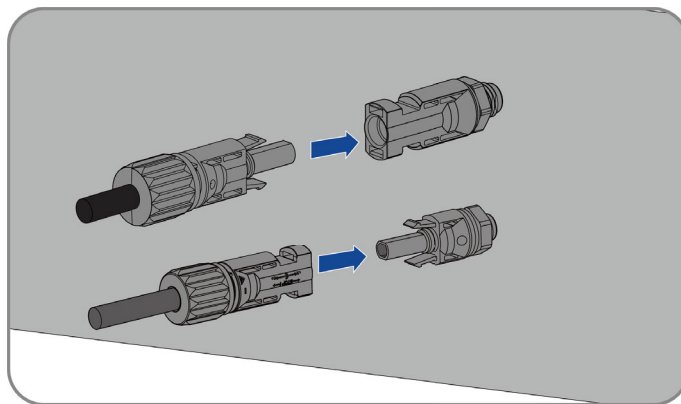

- For unused DC connectors, push down the clamping bracket and push the swivel nut up to the thread. Insert the DC connectors with sealing plugs into the corresponding DC inputs on the inverter.

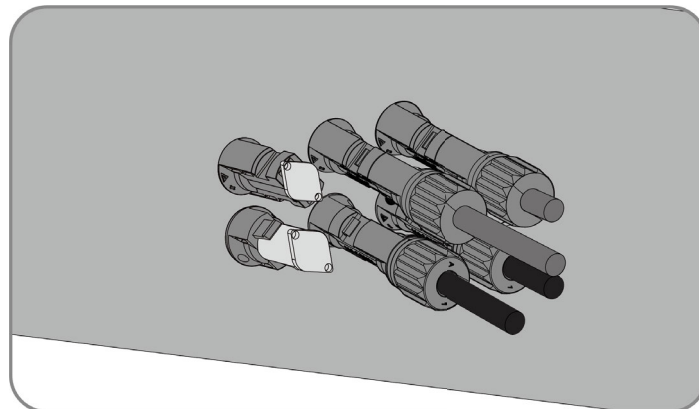



Check the positive and negative polarity of the PV strings, and connect the PV connectors to corresponding terminals only after ensuring polarity correctness. (The graph uses the type 2 connector as an example only.)

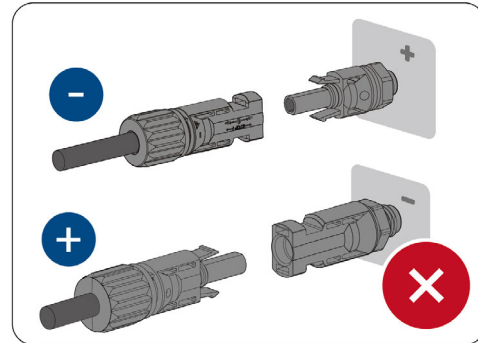
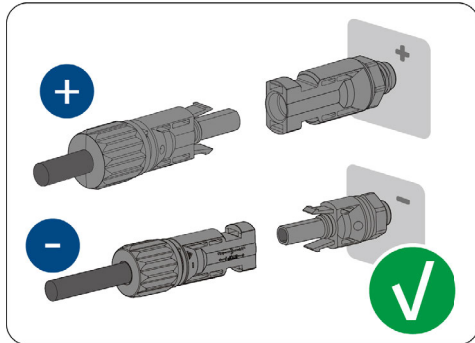

Step 7: Ensure that all DC connectors and the DC connectors with sealing plugs are securely in place.

Complete the installation.

6.7 Battery connection

6.7.1 Requirements for the Battery connection

Assemble the Battery connectors as described in the following section.

Before connecting the battery, it is important to make sure the battery is officially listed in the Hybrid-battery compatibility list, please download the list from the website: <https://solplanet.net/products/asw-5-12kH-T2-T3-series/>.

Assemble the battery connectors as described below. Be sure to observe the correct polarity. The Battery connectors are marked with the symbols “+” and “-”.

A

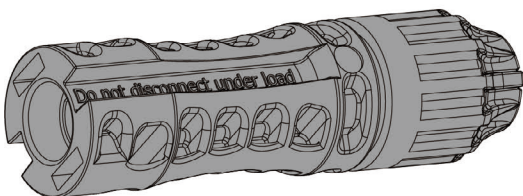

B

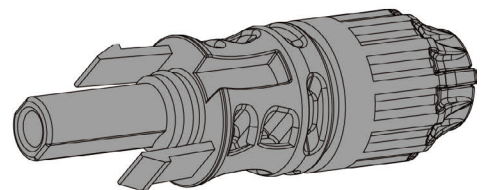

Cable requirements:

Item	Description	Value
1	External diameter	6.4-8.5 mm
2	Conductor cross-section	10 mm ² /8AWG
3	Number of copper wires	At least 7
4	The rated voltage	≥1100v
5	Cable length	≤20m

6.7.2 Assembling the Battery connectors

Procedure:

Step 1: Strip 6-7.5 mm of the cable insulation from the cable.

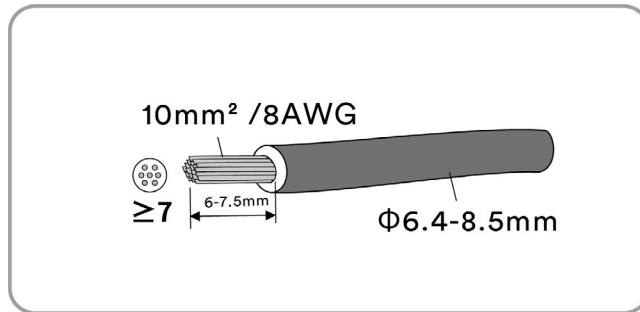

Step 2: Assemble the cable ends with the appropriate crimping tools.

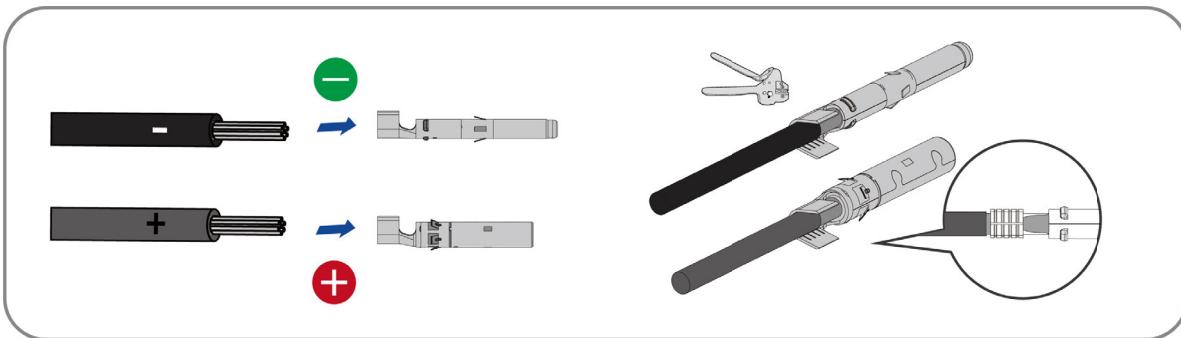

Step 3: Insert the cable through cable gland, and insert into the insulator until it snaps into place. Gently pull the cable backward to ensure firm connection. Tighten the cable gland and the insulator (Torque 4Nm).

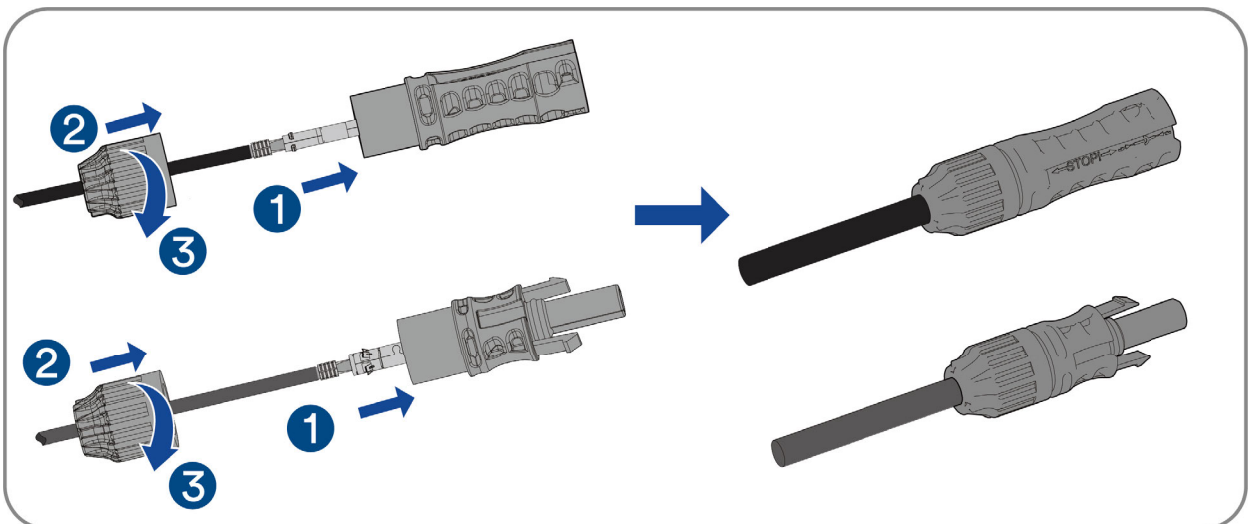

Step 4: Ensure that the cable is correctly positioned.

6.7.3 Connecting the battery connectors

Step 1: Remove the dust and waterproof cover of the BMS connector on the inverter and retain it.

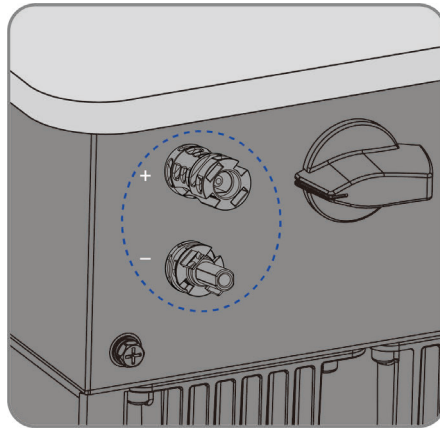

Step 2: Connect the assembled DC connectors to the inverter.

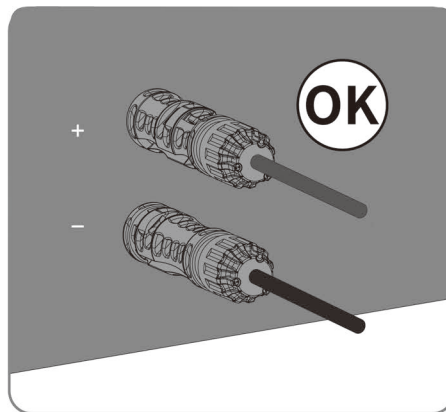
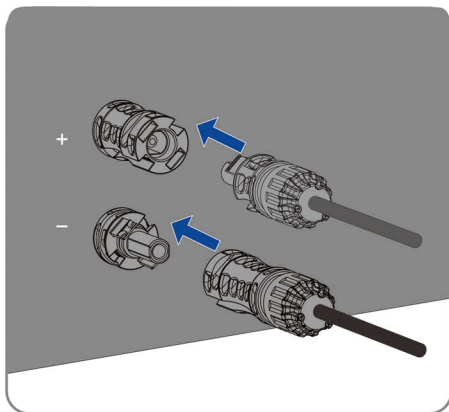

Complete the installation.

6.8Ai-Dongle connection

Procedure:

Step 1: Rotate the nut, take out the sealing ring, hold the locking structure, and take out the wiring terminal.

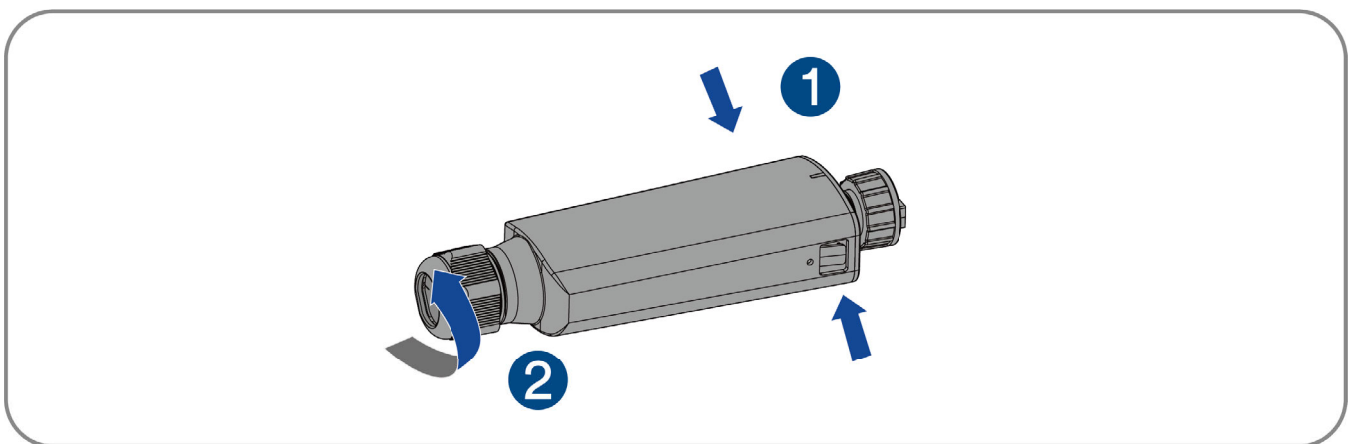

Step 2: Lock the communication cable to the wiring terminal according to the sequence shown in the following figure.

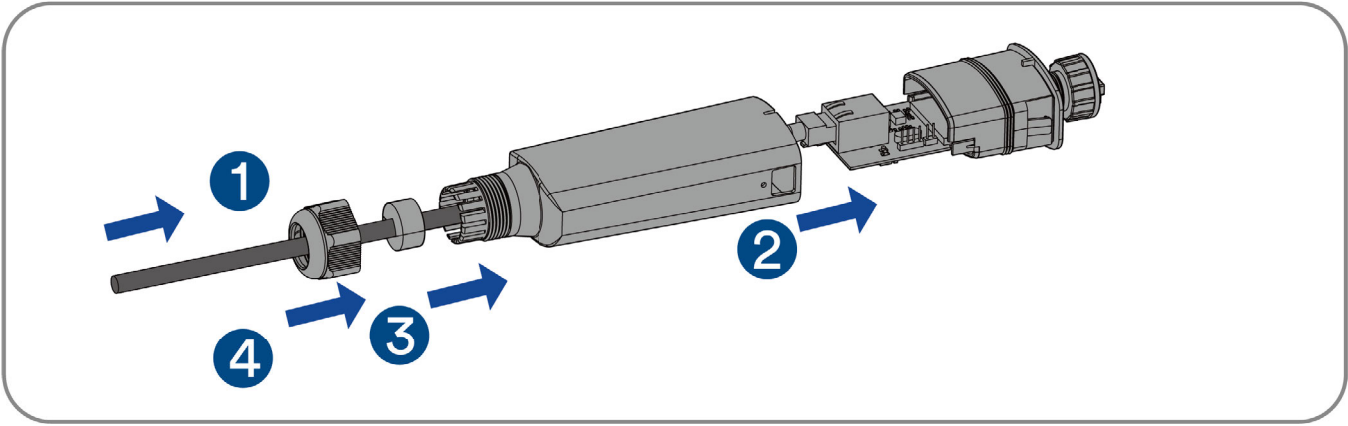

Step 3: Insert the wiring terminal into the sealing head, adjust the communication cable, insert the sealing ring, and lock nut.

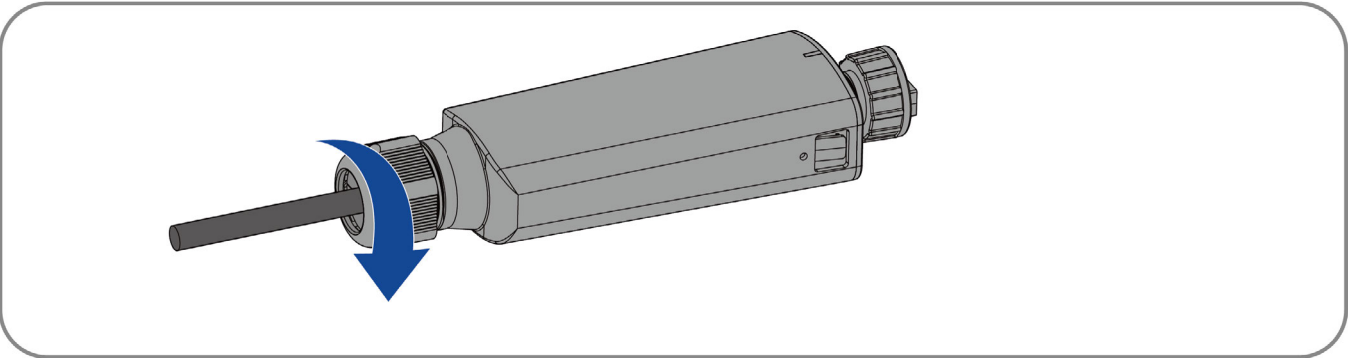

Step 4: Remove the dust and waterproof cover of the Ai-Dongle on the inverter and retain it.

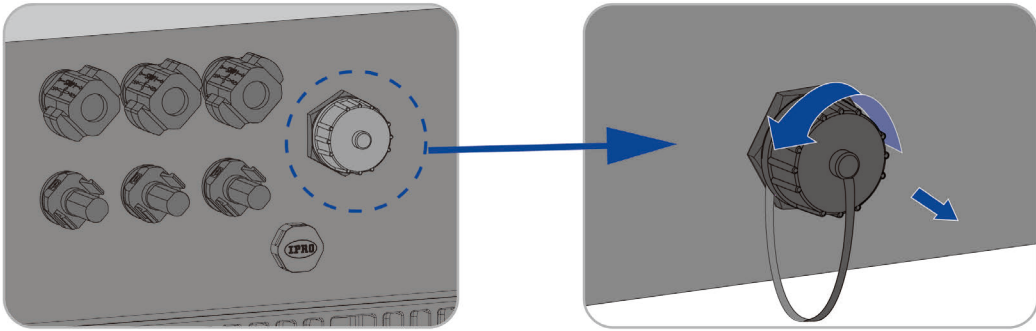

Step 5: Attach the Ai-Dongle to the connection port in place and tighten it into the port by hand with the nut in the modular. Make sure the modular is securely connected and the label on the modular can be seen.

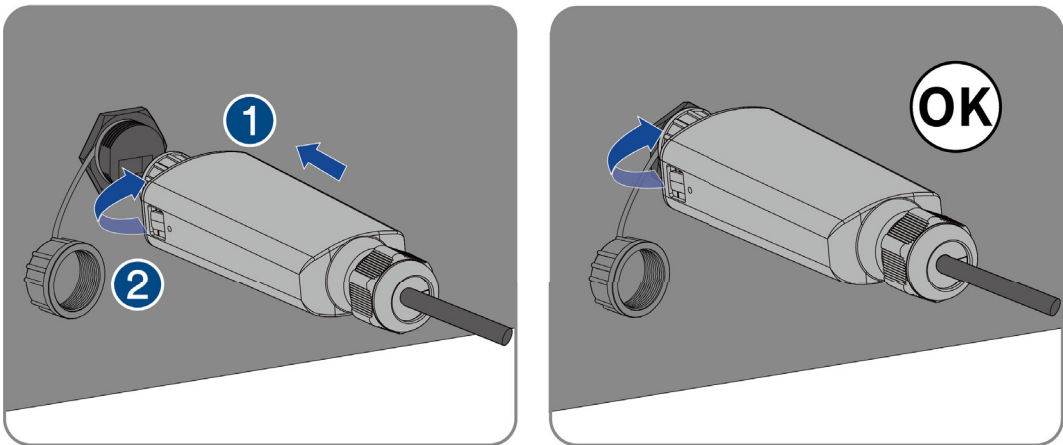

NOTICE

Rotating the body of the Ai-dongle will damage the Ai-dongle!

The Ai-dongle body is protected by locking nuts to protect the reliability of the connection. If it is rotated, the Ai-dongle may become damaged.

It can only be locked by a nut.

- Do not rotate the body of the Ai-dongle.

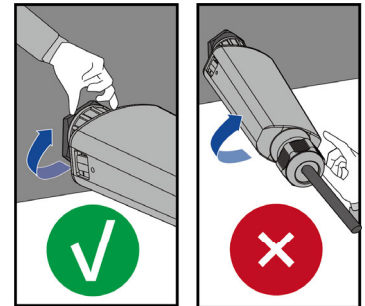

Complete the installation.

6.9 Communication equipment connection

6.9.1 Communication interface description

The inverter is equipped with a communication interface, which is used to connect communication cables such as lithium battery, electricity meter and parallel inverter. The interface configuration of the communication interface is shown in the following figure.

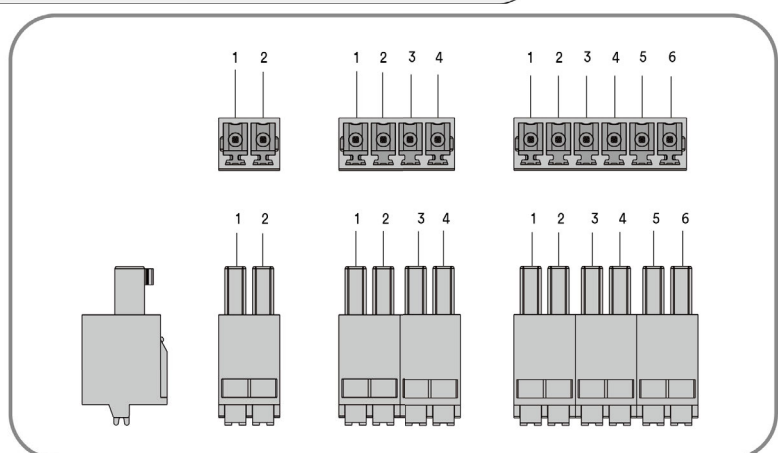
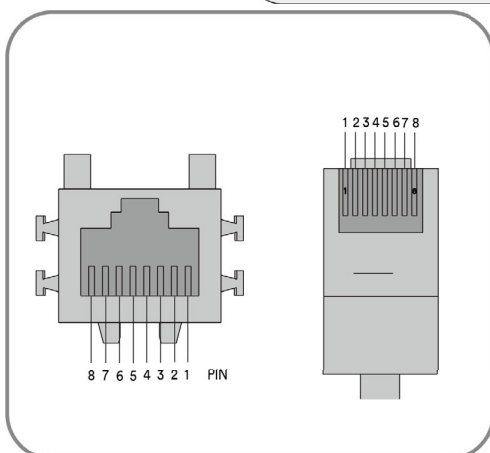
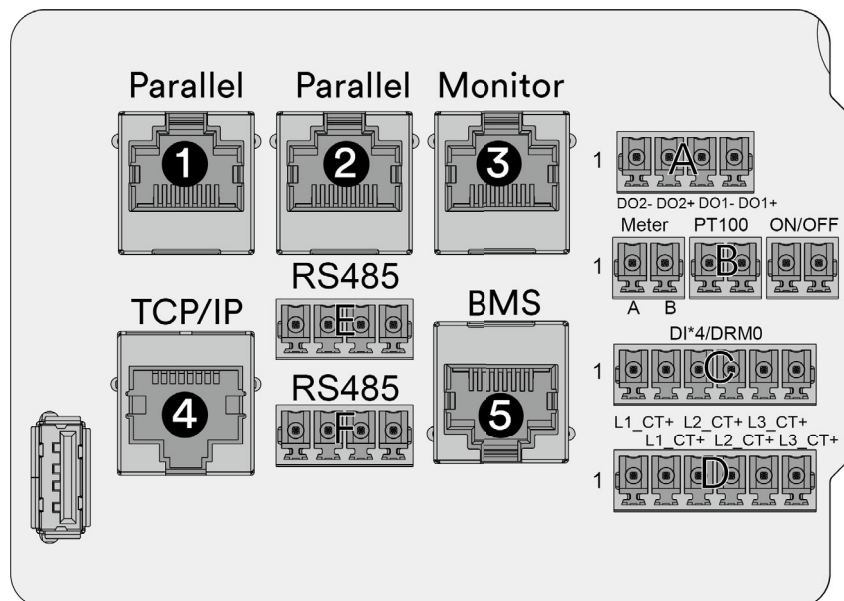

Object	Description	Terminal	PIN definition							
			1	2	3	4	5	6	7	8
④	TCP/IP	RJ-45	TX+	TX-	RX+	X	X	RX-	X	X
⑤	BMS	RJ-45	X	GND	X	CANAH	CANAL	X	X	X
③	Monitor	RJ-45	RS485A	RS485B	GND	X	X	X	X	X

Object	Description	Terminal	PIN definition					
			1	2	3	4	5	6
A	DO2/DO1	4pin	Multifunction Relay		Multifunction Relay/Generator startup signal Relay		\	
			A	B	A	B		
B	\	6pin	Smart Meter		\		NS-protection (network and system protection) Device	
			RS485A	RS485B	Positive	Negative		
C	DI*4/DRM0	6pin	Ripple Control Receiver Device				DRMS Device	
			DI_4	DI_3	DI_2	DI_1	REF GEN/0	COM LOAD/0 or GND
D	CT	6pin	Current Transformer L1		Current Transformer L2		Current Transformer L3	
			Red	Black	Red	Black	Red	Black
E*1	RS485	4pin	RS485A	RS485B	GND	/		
F*1	RS485	4pin	RS485A	RS485B	GND	/		

Com port	Description	Function
USB	USB port	Reserved
① ② E F	RS485 port	The RS485 interfaces used for the product parallel operation.
③	Monitor device	The PIN1、 PIN2 of RS485 interface used to connect the product to the third-party monitor device. If you don't want to use Ai-Dongle, the third party monitor device can be used.
⑤	BMS communication port	The RS-485/CAN interface used to connect the BMS (Battery Management System) of the battery. If the communication interface of the BMS is CAN interface, the pins for CAN interface can be chosen to connect.
A	Multifunction Relay/Generator startup signal Relay	The product comes standard with two multifunctional relays that can withstand up to 250V/1A. Multifunctional relays can be configured to operate in specific systems such as heat pump signal or generator startup signal. The generator startup signal is fixed to the Relay between Pin3 and Pin4. For more information, please contact AISWEI Services.
B	Smart Meter	Terminal 2 can be used to connect the smart meter and NS-protection

	NS-protection (network and system protection) Device	(network and system protection) device. The PIN definition is shown as above table.
C	Ripple control receiver device DRMs device	Terminal 3 can be used to connect the ripple control receiver and DRMs device. The PIN definition is shown as above table. Especially the PIN 6 (GND) is a common port for both devices. For DRM0 application, please connect PIN5 (REF GEN) and PIN6(COM LOAD). When selecting VDE 4105 in the Grid code setting, the function of ENWA 14a can be realized.
D	Current transformer	Terminal 4 can be used to connect three current transformers. The PIN definition is shown as above table.



The NS protection control signal requires 10-24V voltage.

6.9.2 Communication cable connection

Step 1: Remove the communication cover.

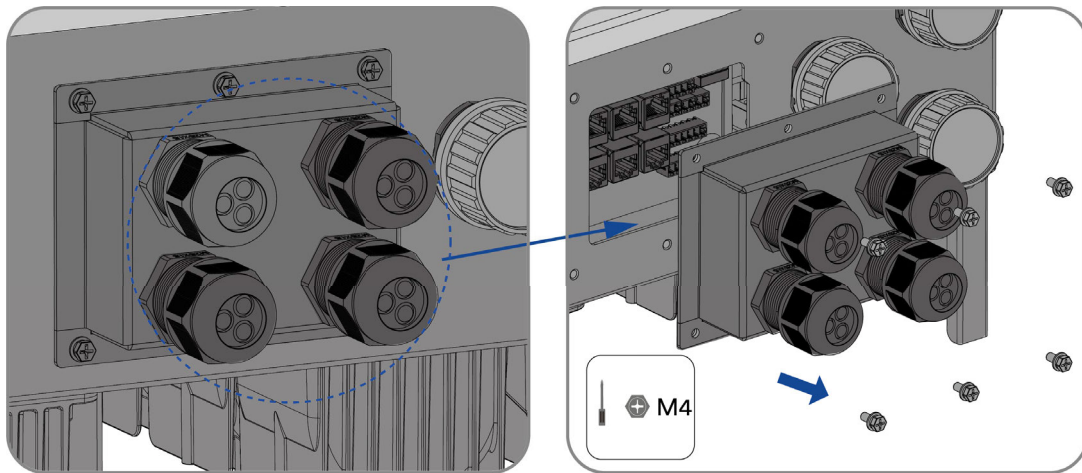

Step 2: Route the communication cable through the communication cover and crimp the wiring terminal.

The sequence of the crimping wires of the wiring terminals is shown in the following figure:

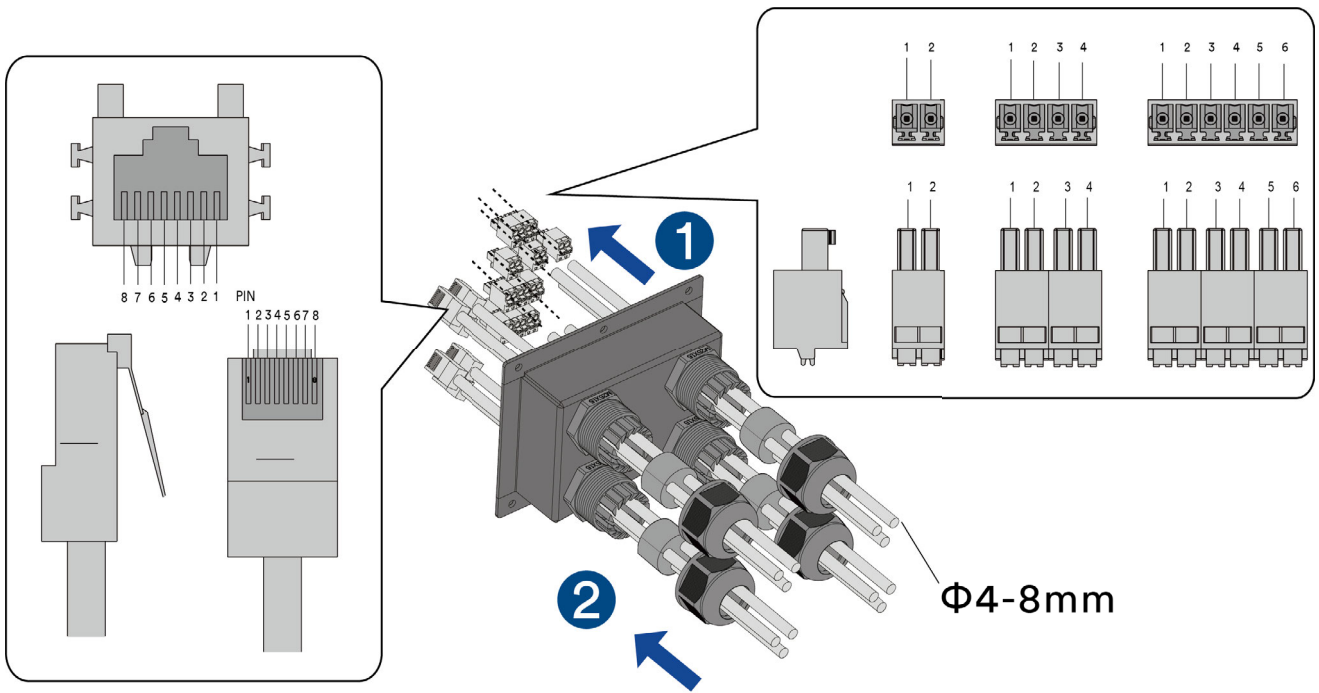

Step 3: Connect the communication cable crimped to the corresponding communication port.

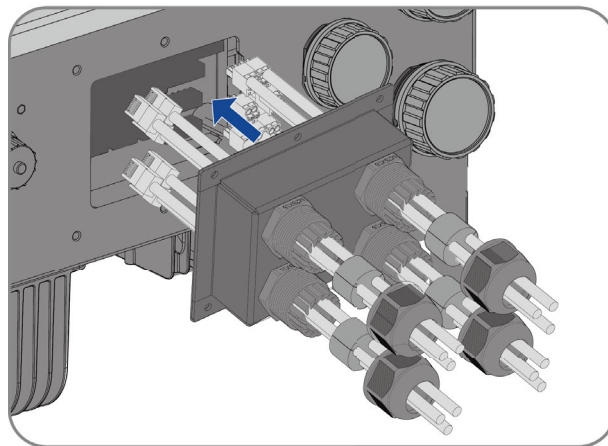

Step 4: Install the communication cover on the inverter.

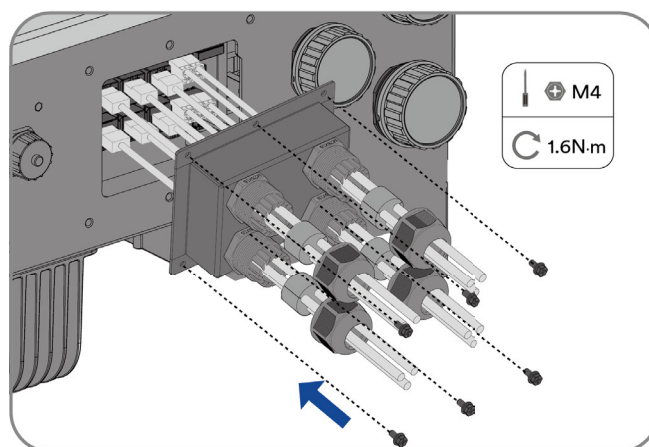

Step 5: Tighten the cable gland nuts.

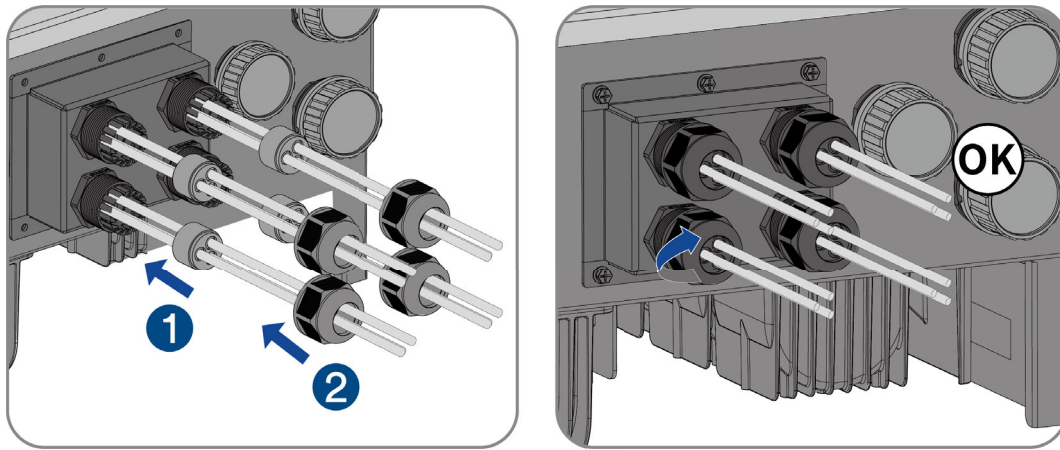

Complete the installation.

6.9.3 Ripple control receiver connection

The product is equipped with one interface (terminal block C) to connect a Ripple Control Receiver device. The Ripple control receiver device can be connected to terminal block C (pin1~pin4, pin6).

Position	PIN	Assignment
1	DL_4	
2	DI_3	
3	DI_2	
4	DL_1	
5	DRM 0	
6	GND	

Step 1: Remove the cable jacket and strip the wire insulation.

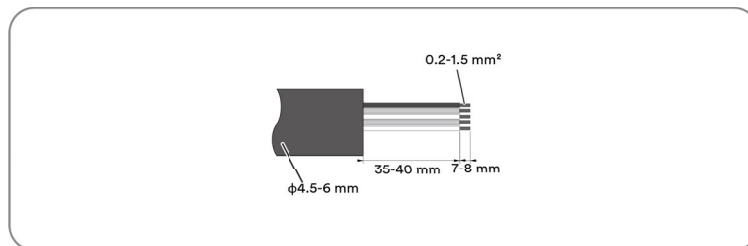

Step 2: Remove the push-in connector from the accessory pack. Insert the stripped wires into the push-in terminal connector.

Step 3: Insert the push-in connector into the connection panel and ensure the connection is secure.

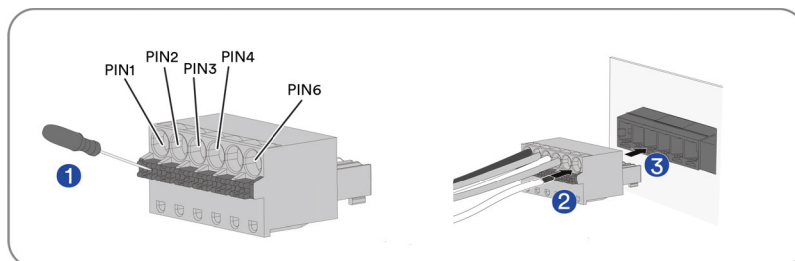

Step 4: Strip the insulation of the other end of the cable and terminate the wire into the terminal of the ripple control receiver according to the ripple control receiver requirements. Refer to the user manual of the ripple control receiver for further information.

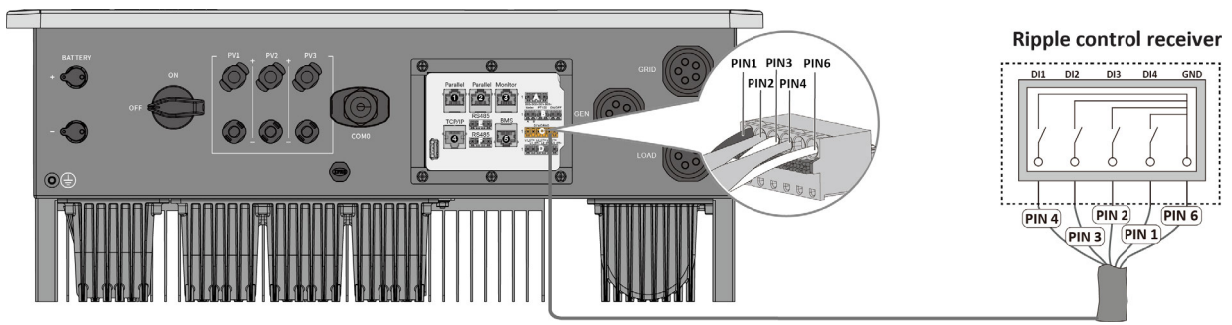

Installation completed.

6.9.4 NS protection connection

The product is equipped with one connection (terminal block B) for connection to an external central grid protection device.

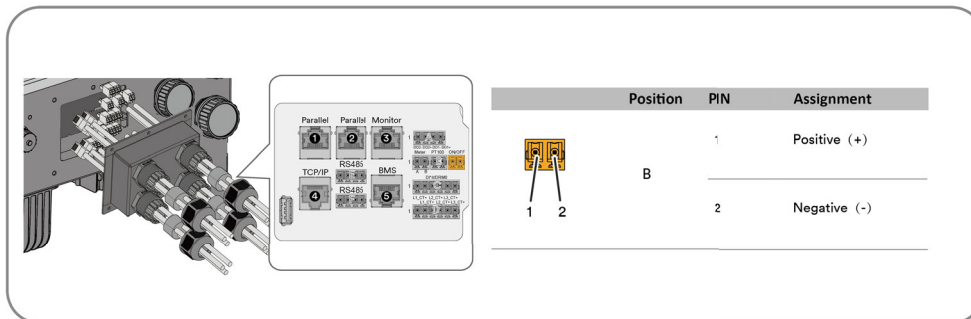

Step 1: Remove the cable jacket and strip the wire insulation.

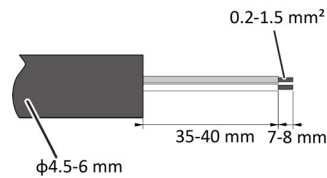

Step 2: Remove the push-in connector from the accessory pack. Insert the stripped wires into the push-in terminal terminals.

Step 3: Insert the push-in connector into the connection panel and ensure the connection is secure.

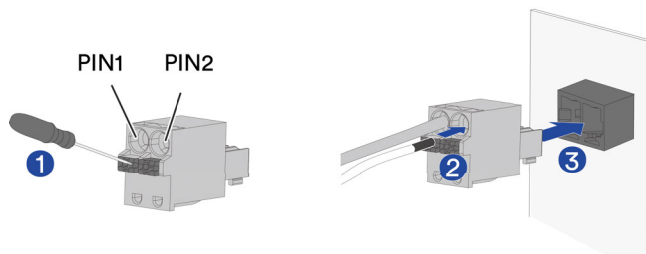

Step 4: Strip the insulation of the other end of the cable and terminate the wire into the terminal according to external protection device requirements. Refer to the user manual of the external protection device for further information.

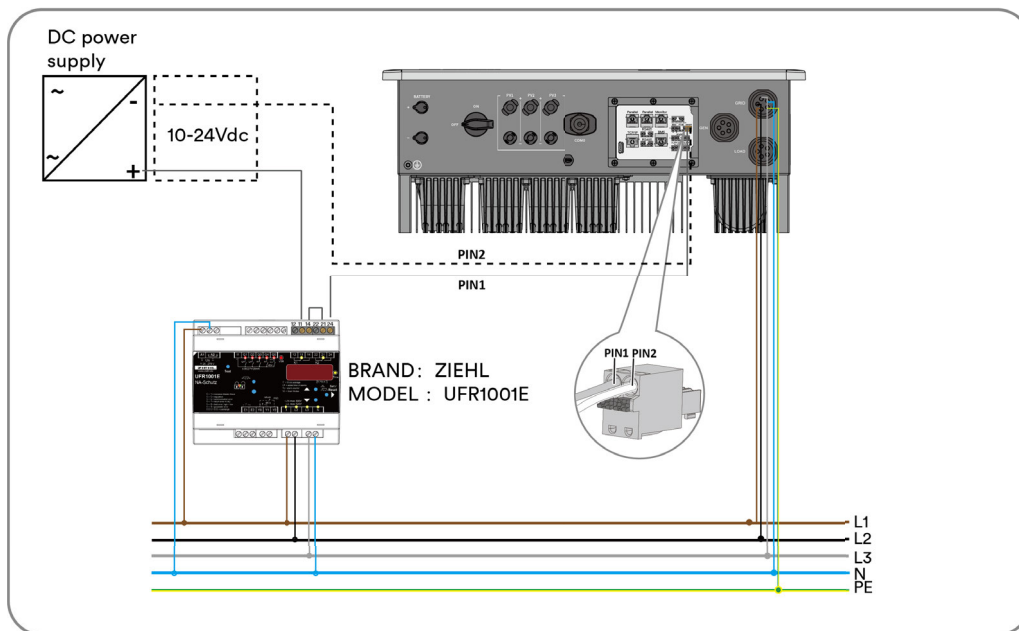

Installation completed.



The Figure above is as reference and the manual of the third party device should be consulted, as also the manuals of other brands.

6.9.5 Current Transformer connection

CT is an optional accessory.

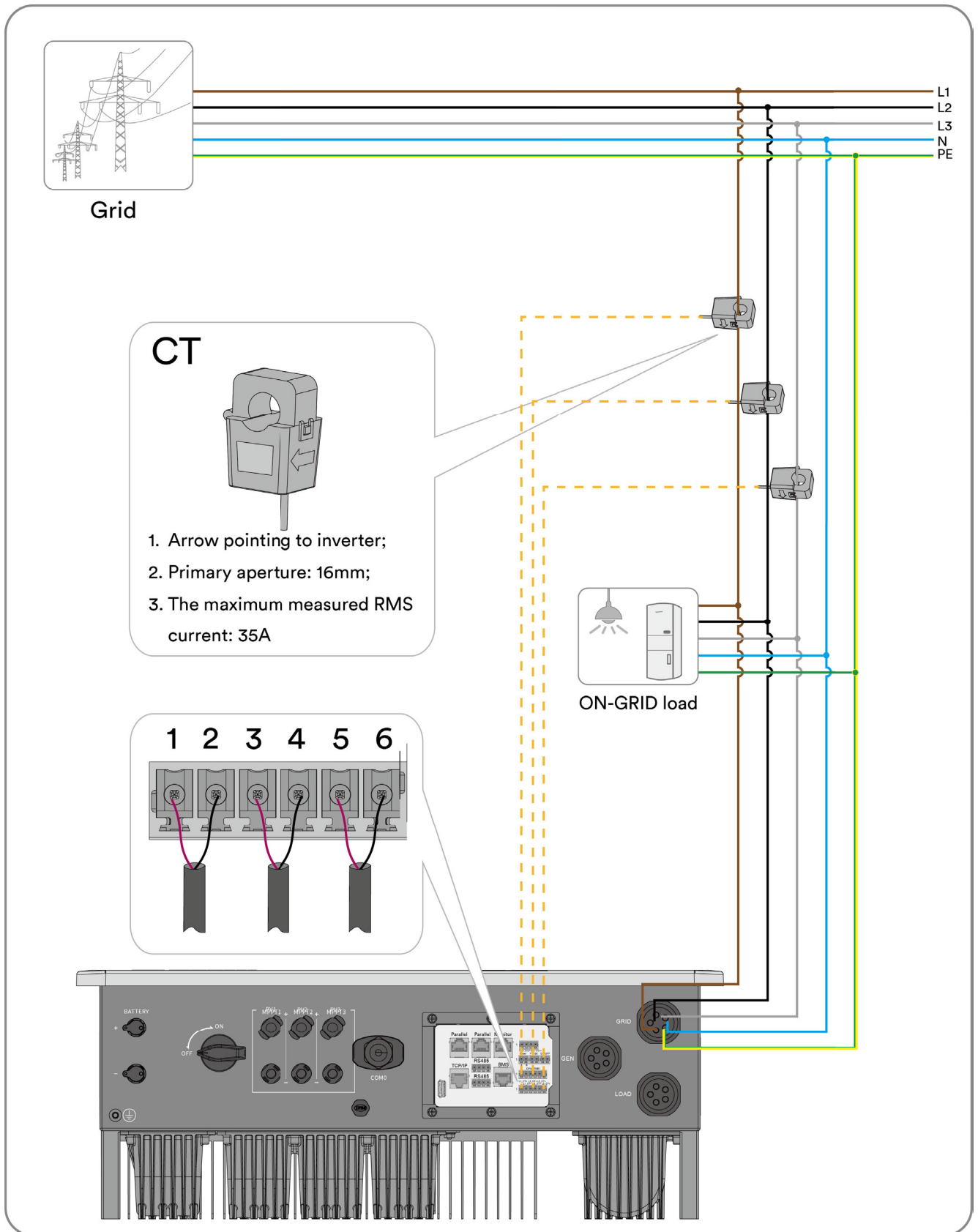

6.9.6 Smart meter connection (Eastron SDM630-Modbus V2)

The grid structure supported by the product is TN-S. For other grid types, please refer to 4.4.

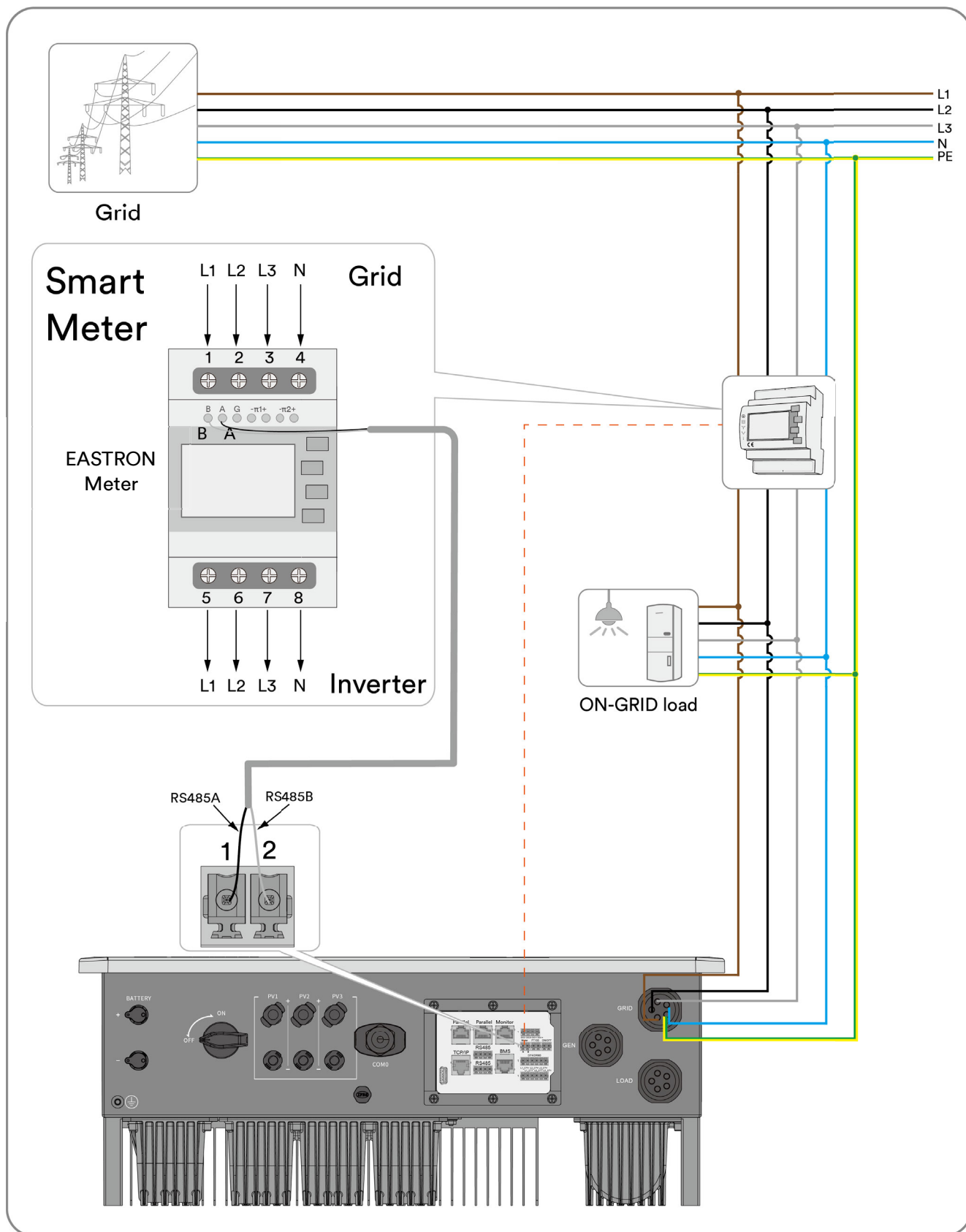

6.9.7 Smart meter connection (CHINT DTSU666)

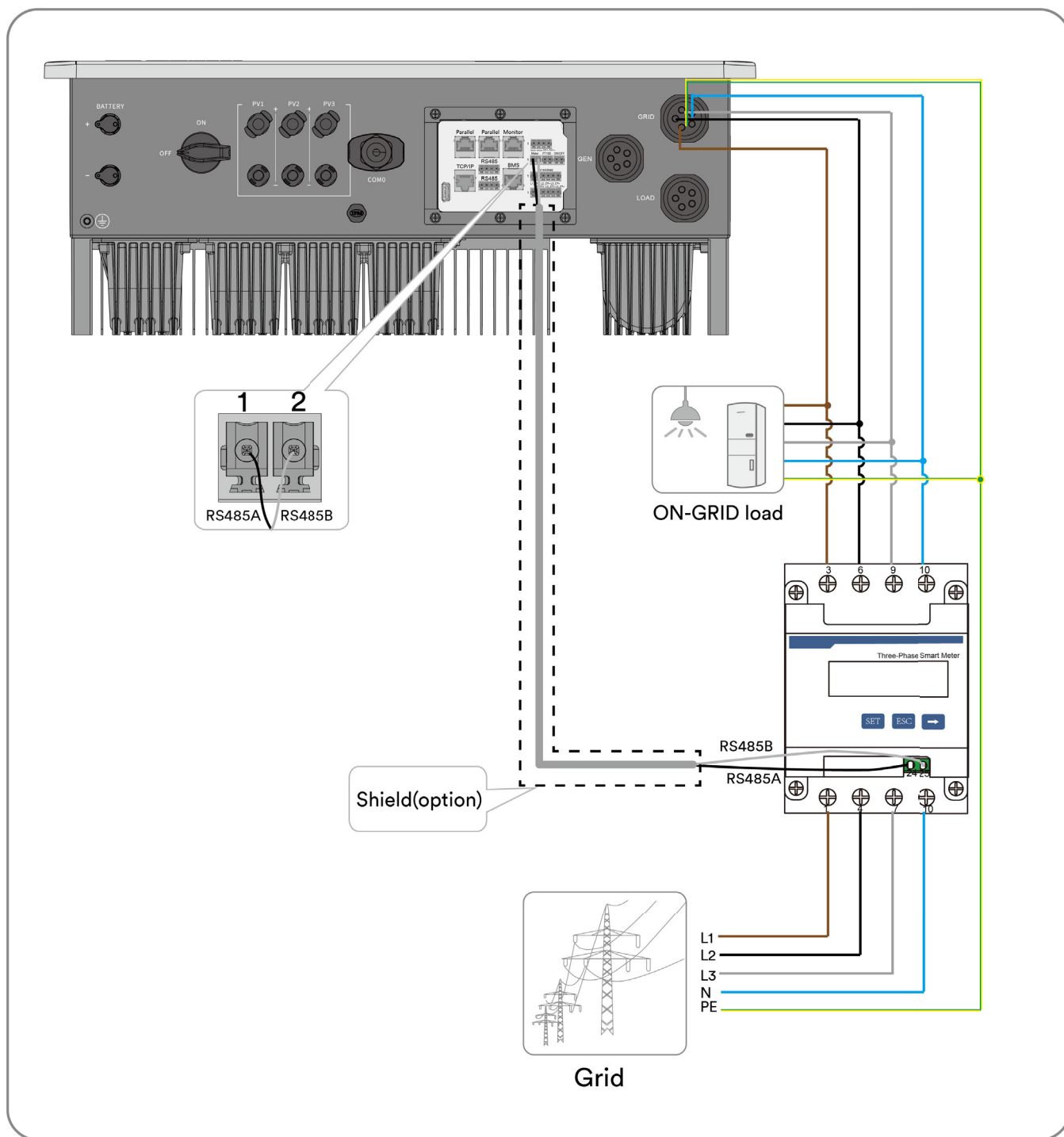

NOTICE

Only Eastron and CHINT meters are supported. Meter in the attachment bag is CHINT DTSU666 . Models that support EASTRON meters are EASTRON SDM630-Modbus V2 and EASTRON SDM630MCT V2 . Only meters provided by Soplanet can be used.

7 Commissioning and operating

7.1 Inspection before commissioning

CAUTION

Danger to life due to high voltages on DC conductors!

When exposed to sunlight, the PV array generates dangerous DC voltage which is present in the DC conductors. Touching the DC and AC conductors can lead to lethal electric shocks..

- Only touch the insulation of the DC cables.
- Only touch the insulation of the AC cables.
- Do not touch ungrounded PV modules and brackets.
- Wear personal protective equipment, such as insulating gloves.

Check the following items before starting the inverter:

- Make sure the inverter DC switch and external circuit breaker are disconnected.
- Make sure the inverter has been correctly mounted with wall bracket.
- Make sure nothing is left on the top of the inverter.
- Make sure the communication cable and AC connector have been correctly wired and tightened.
- Make sure the inverter's exposed metal surface has a ground connection.
- Make sure the DC voltage of the strings does not exceed the permitted limits of the inverter.
- Make sure the DC voltage has the correct polarity.
- Make sure that the insulation resistance to ground is greater than the insulation resistance protection value.
- Make sure the grid voltage at the point of connection of the inverter complies with the permitted value of the inverter.
- Make sure the AC circuit breaker complies with this manual and all applicable local standards.
- Make sure The phase sequence of the grid-side wiring of all parallel inverters is completely consistent. If EPS is parallel , the EPS phase sequence also must be completely consistent.

7.2 Commissioning procedure

If all of the items mentioned above meet the requirements, proceed as follows to start up the inverter for the first time.

Step 1: Turn the DC switch of the inverter to "ON" position and turn on the battery, keep the breakers on EPS and grid port to "OFF" position.

Step 2: Connect the inverter with soplant APP, For details, please refer to 8.4. Then set grid code, operation mode(refer to 4.7), meter or CT type, battery model and SOC limit refer to 8.4.

Step 3: Turn the breakers on EPS and grid port to "ON" position. If the irradiation and grid conditions meet requirements, the inverter will operate normally.

Step 4: Observe the LED indicator to ensure inverter operates normally, check the inverter and battery parameters in APP.

8 Solplanet APP

8.1 Brief introduction

The Solplanet App can establish communication connection to the inverter via the WLAN, there by achieving near-end maintenance on the inverter. Users can view inverter information and set parameters through the App.

8.2 Download and install

Scan the following QR code to download and install the App according to the prompt information.



Android



iOS

8.3 Create an account

If you do not have an account, you need to register a new account first.

Procedure:

Step 1: Open Solplanet App to enter the login screen, and tap “Do not have an account” to enter the next screen.

Step 2: The user groups “Business user” and “End user” need be selected according to your identity, and tap “Next step”.



The end user and the business user have the different permissions for setting parameters.

The end user only can set the parameter during commissioning. The business user has more permissions, but they need submit more identity authentication documents.

Step 3: Enter the right mobile phone number (Via SMS) or E-mail address (Via mail). And tap the “Send verification code”

Step 4: Enter the correct verification code to automatically enter the next page.

Step 5: Set the password and click “Register” to complete the registration.

8.4 Create a plant

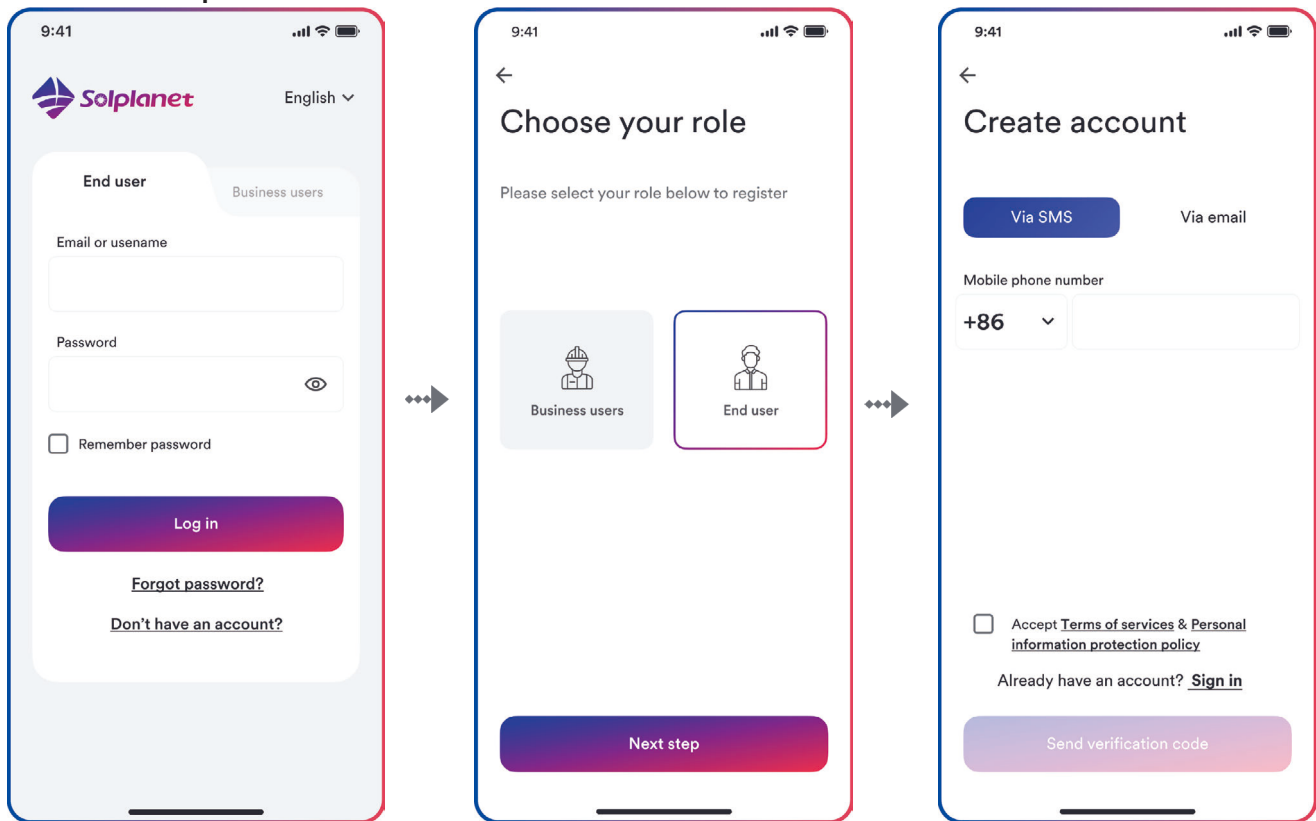

Step 1

Step 2

Step 3

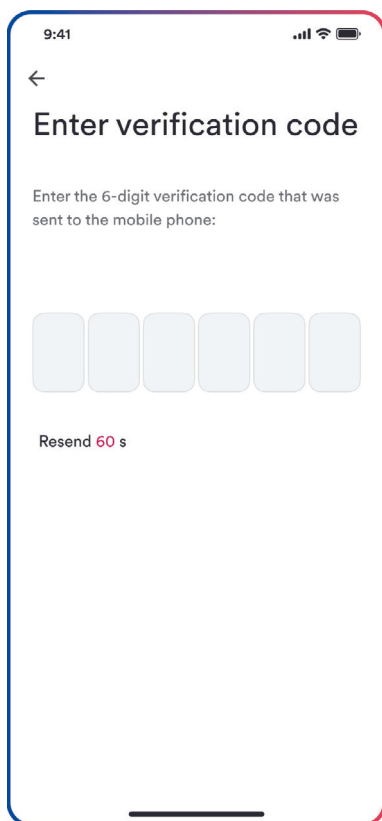

Step 4

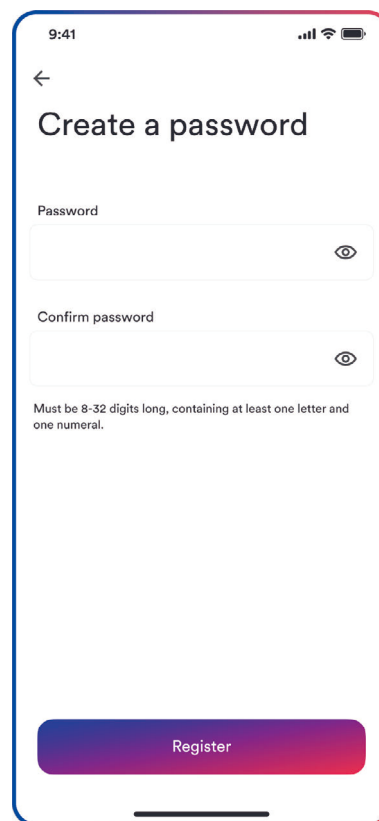

Step 5

Procedure:

- Step 1:** Open Solplanet App to enter the login screen, enter the account name and password, and tap “Log in” to enter the next screen.
- Step 2:** Tap the symbol “+” to enter the next screen, and tap “Create or modify a plant”, then the camera of the mobile automatically turns on, and scan the QR code of the Ai-dongle to enter the next screen, tap “Create new plant” to the next screen.
- Step 3:** Enter the PV plant information in all fields marked with a red asterix, and tap “Create” to enter the next screen.
- Step 4:** After the planet created, tap “Add dongle to the plant”, and tap “Add to plant” to the next screen.
- Step 5:** If the plant is a parallel system, please refer to section 8.6 "Additional parameters settings for the parallel system" after Step 5.



If the plant is a parallel system, please refer to section 8.6 "Additional parameters settings for the parallel system" after Step 5.

- Step 6:** Tap the inverter serial number that matches your inverter, then the setting parameter can be set. The detail description can be found at section 8.5.



The grid code should be chosen at this step. And the parameters also should be set if the grid company has the different requirements.

- Step 7:** The Energy Management shall be set here. Tap “Energy storage settings” to the next page, then tap “Battery settings” to select the battery model, battery number and choose the energy management model. After the parameter configuration, tap “Confirm” and tap the left arrow to go back the inverter list page. Then tap “Next step” to enter the next page.



The battery discharge minimum is valid only in grid-connected mode, and the off-grid default is 10%.

- Step 8:** The parameter of the “Export Power Control” can be set, and tap “Save” after the parameter configuration. Then tap “Nest step” to enter the next page.
- Step 9:** Tap “Continue”, and choose WiFi network from the list, and enter WiFi network password. Then tap “continue” to enter the next step.
- Step 10:** Observe whether the Led blue light of the dongle stays on. If it is always on, it means that the network configuration is successful, and you can tap “Complete” to complete the configuration. Otherwise, you need to go back to the previous step and re-enter the Wi-Fi password.
- Step 11:** Now the new plant have been created. Tap the plant to review the information of the plant.

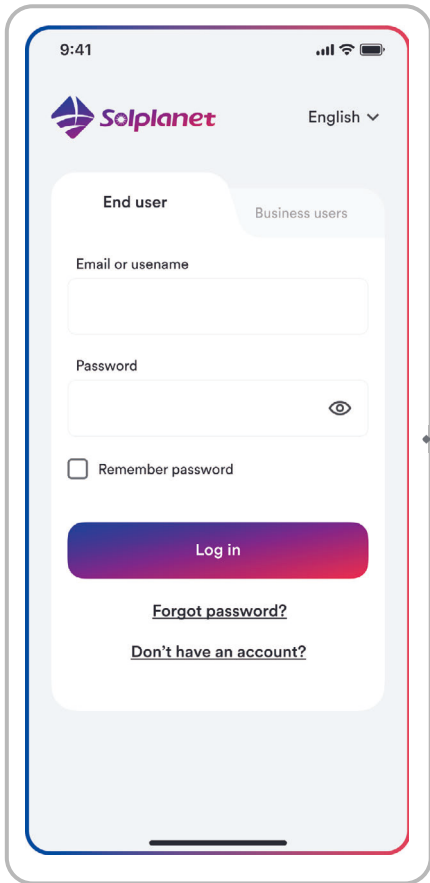

Step 1

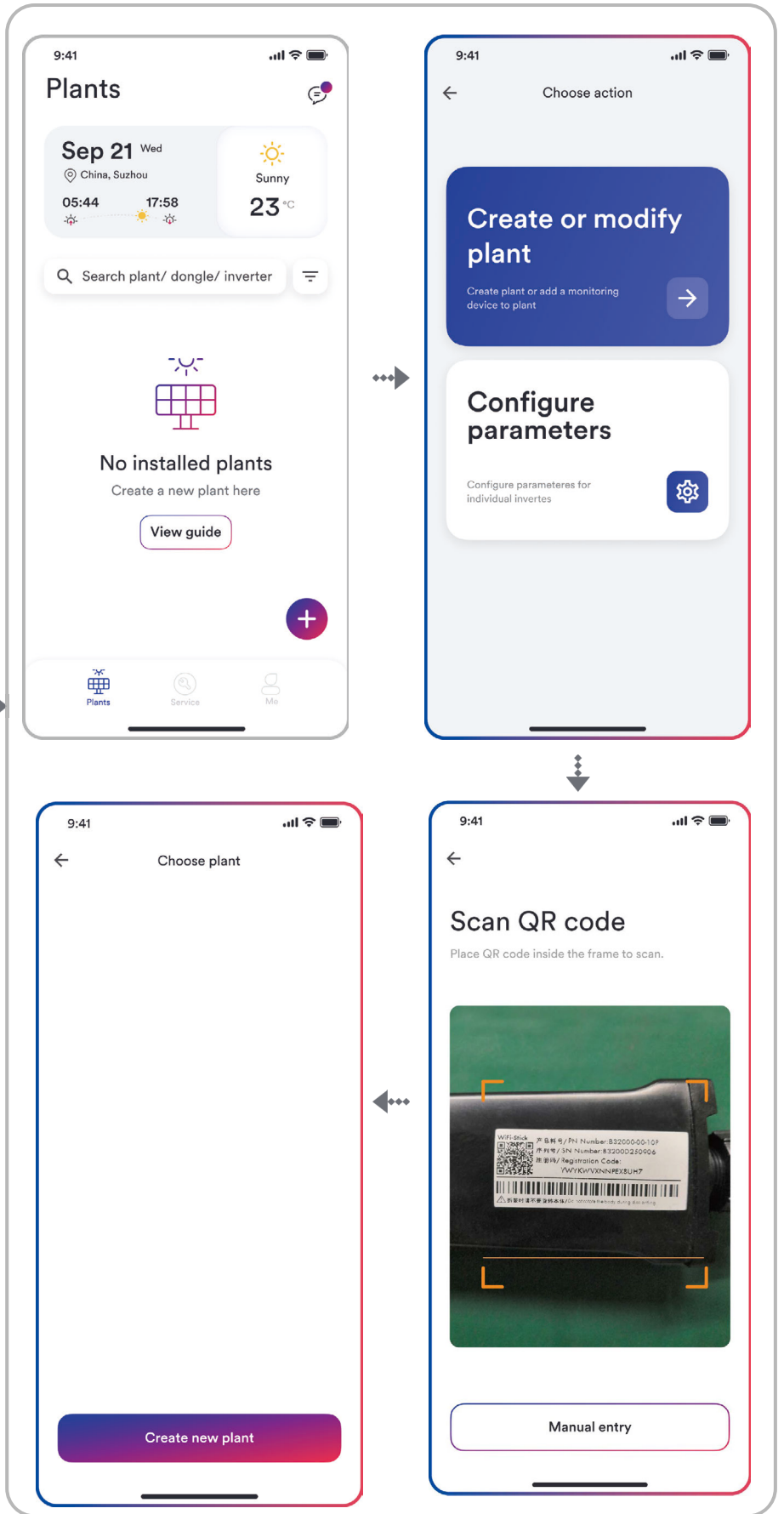

Step 2

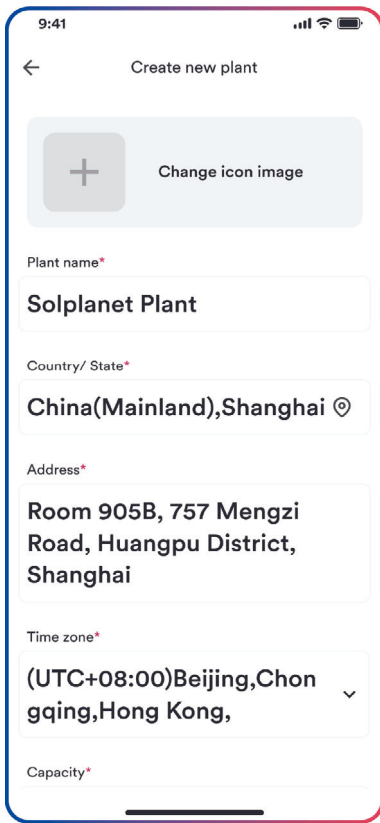

Step 3

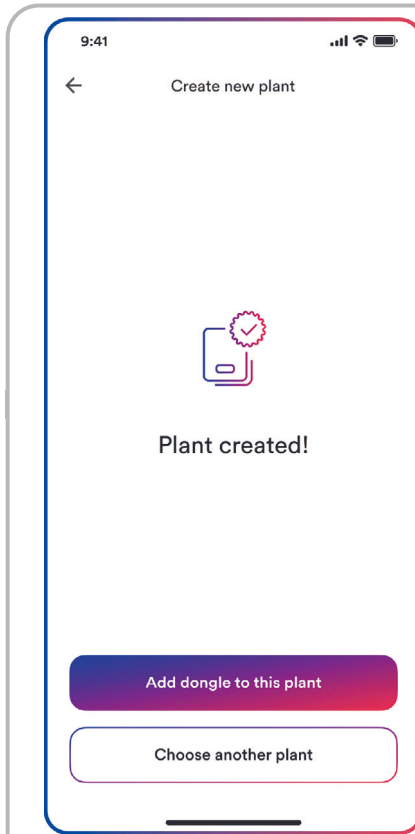

Step 4

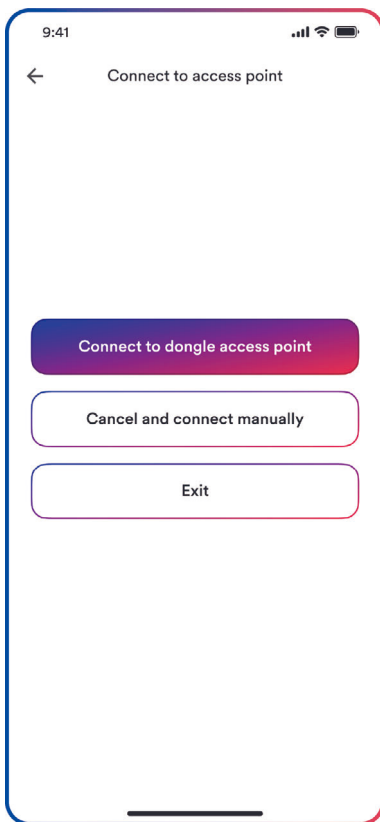
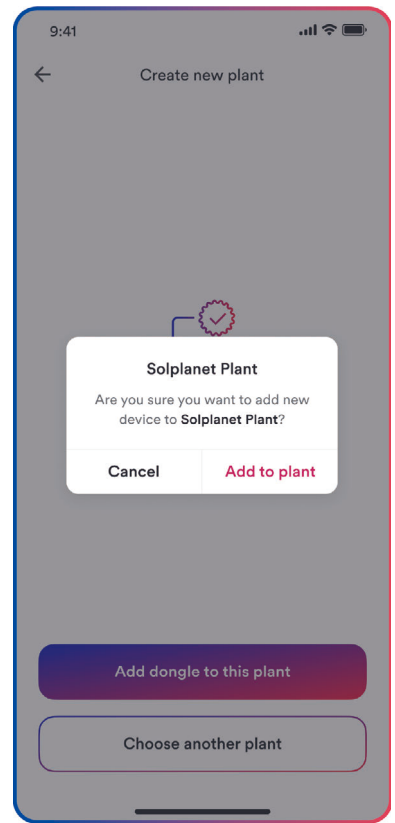

Step 5

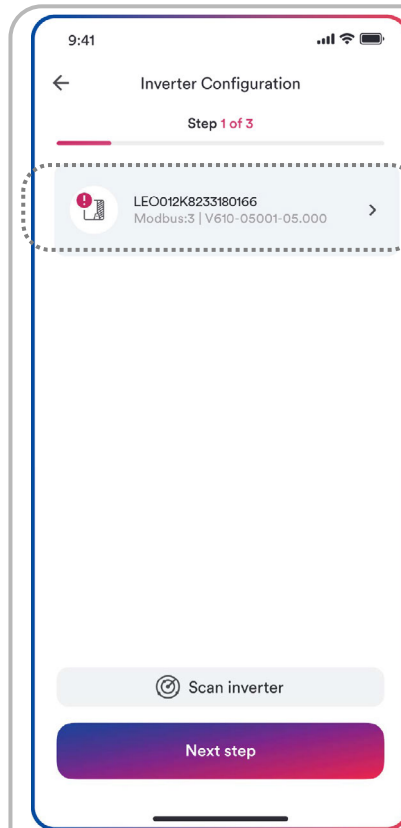

Step 6

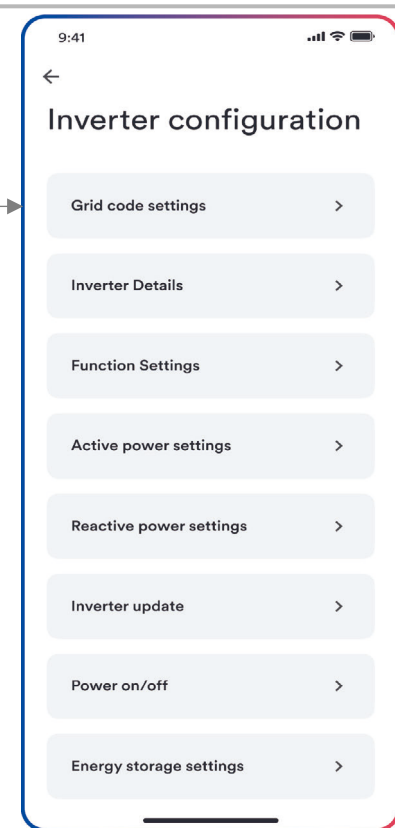

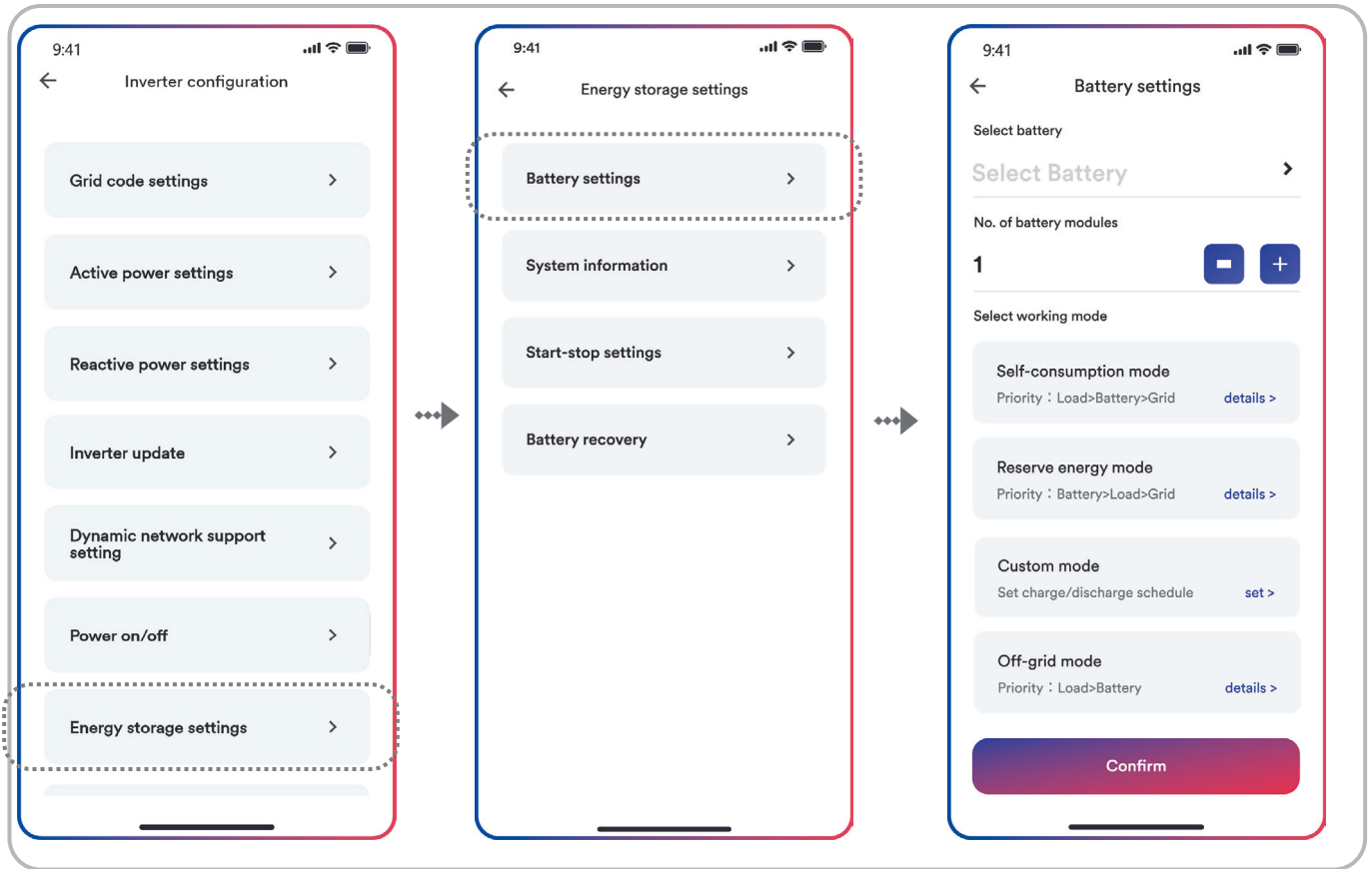

Step 7

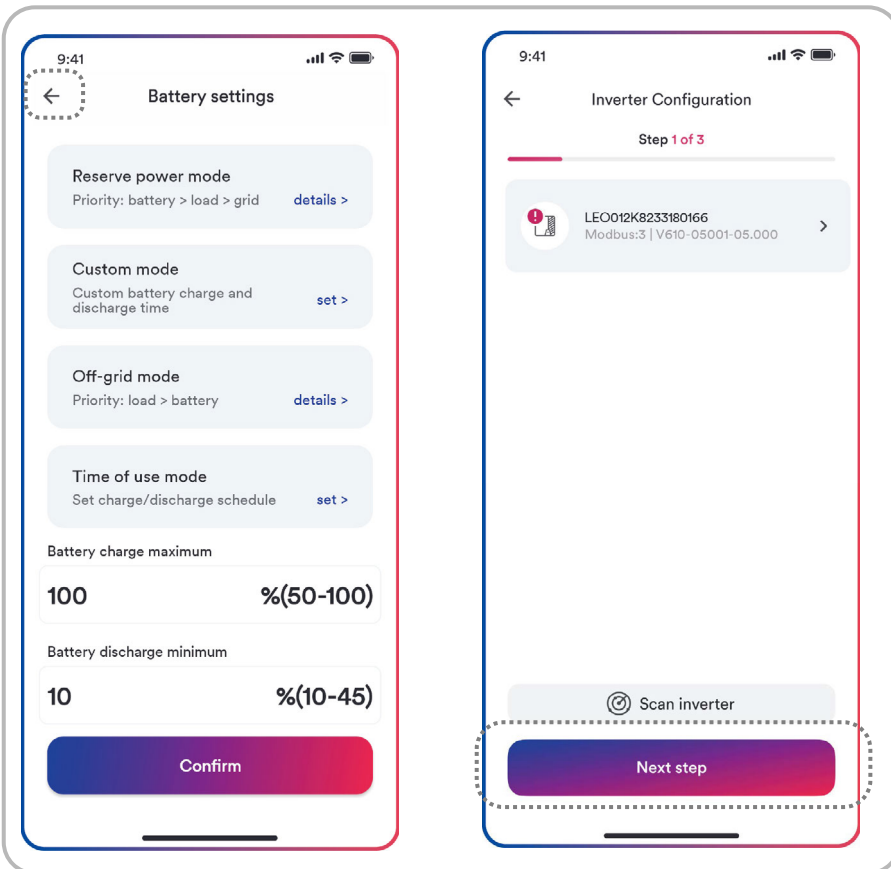

Step 7

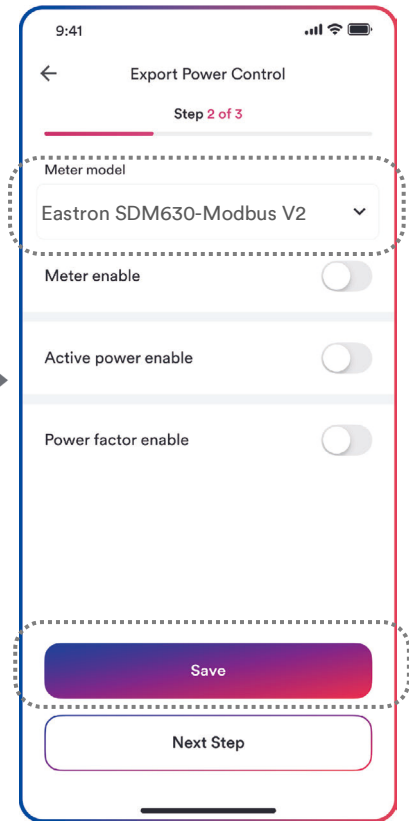

Step 8

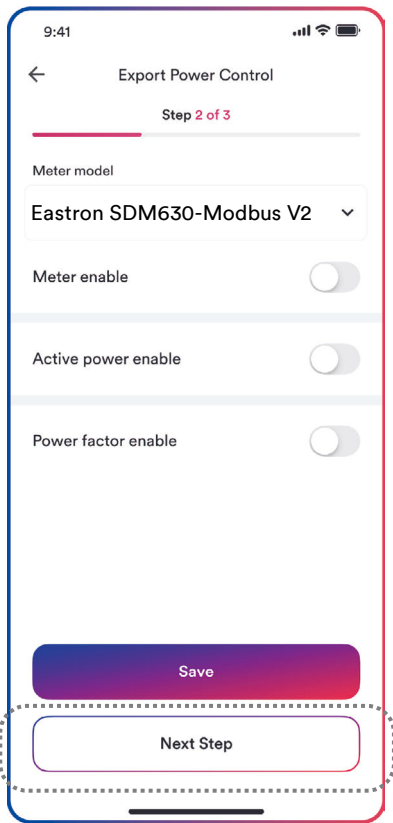

Step 8

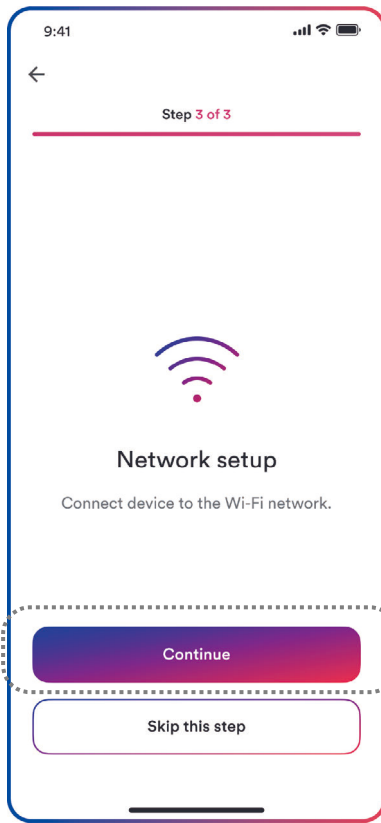

Step 9

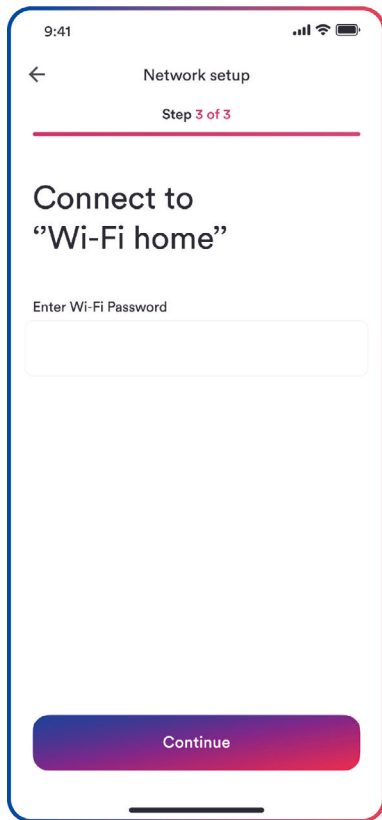
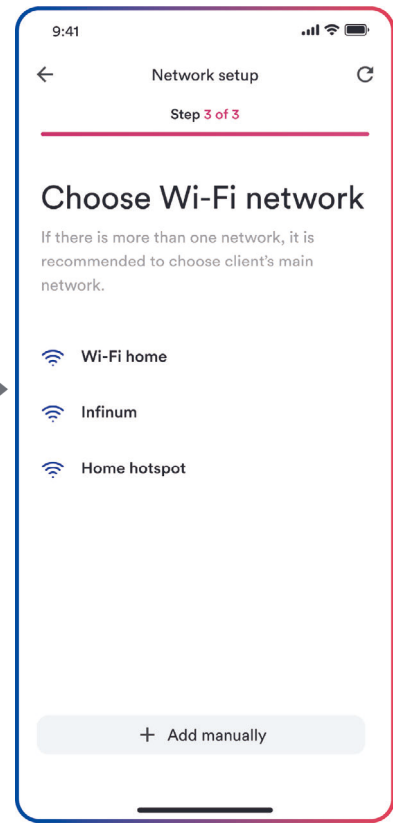

Step 9

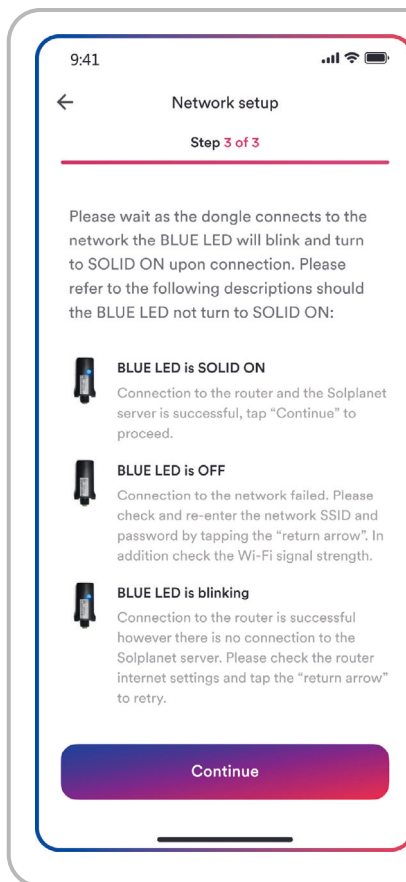

Step 10

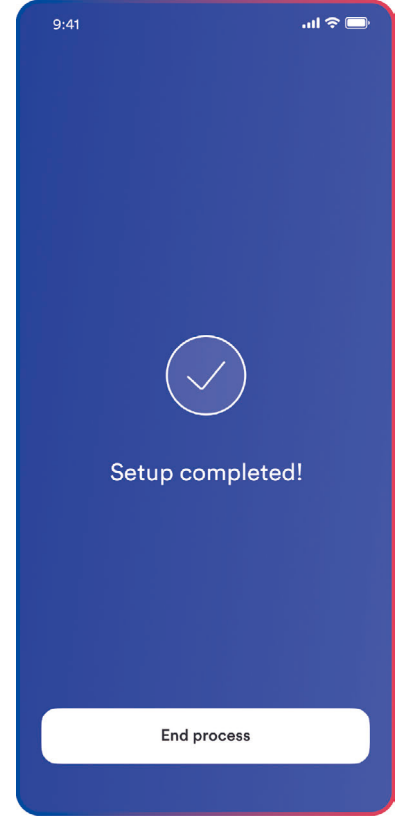

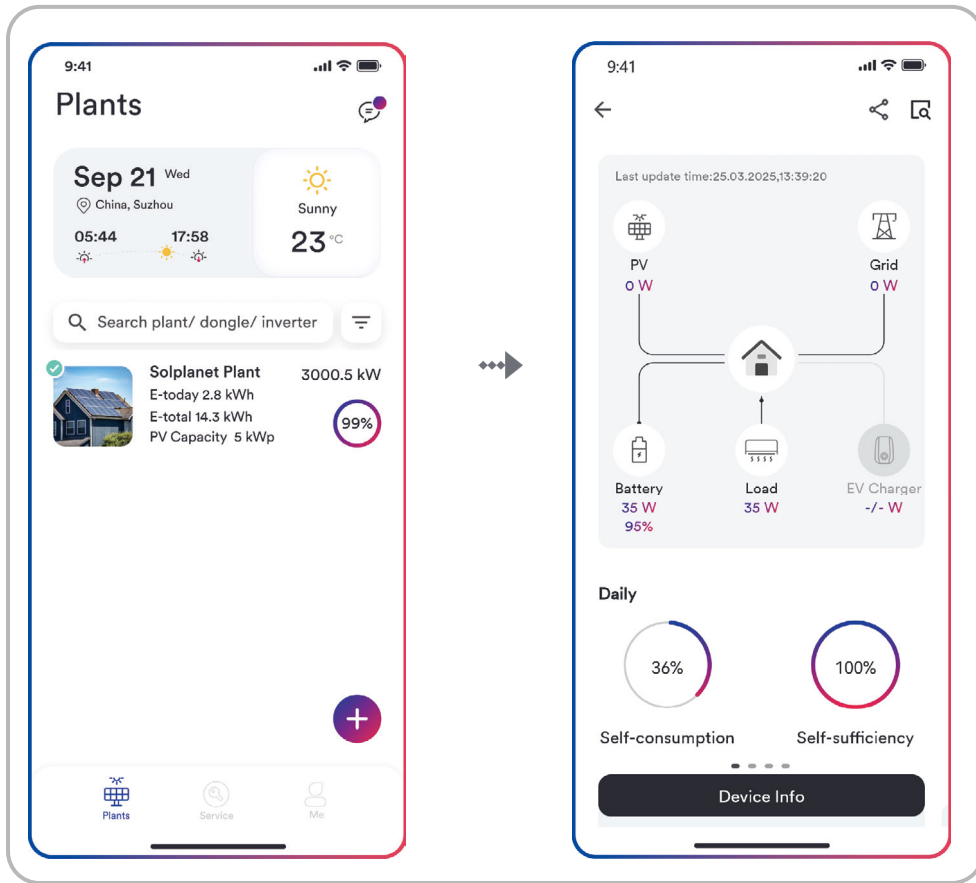

Step 11

8.5 Setting parameters

8.5.1 Inverter configuration

The Solplanet's products comply with local grid code when leaving the factory. But you still should check the grid code and the parameters according to the requirements of the installation site.

Once configuration of the product is completed, the product will start operating automatically

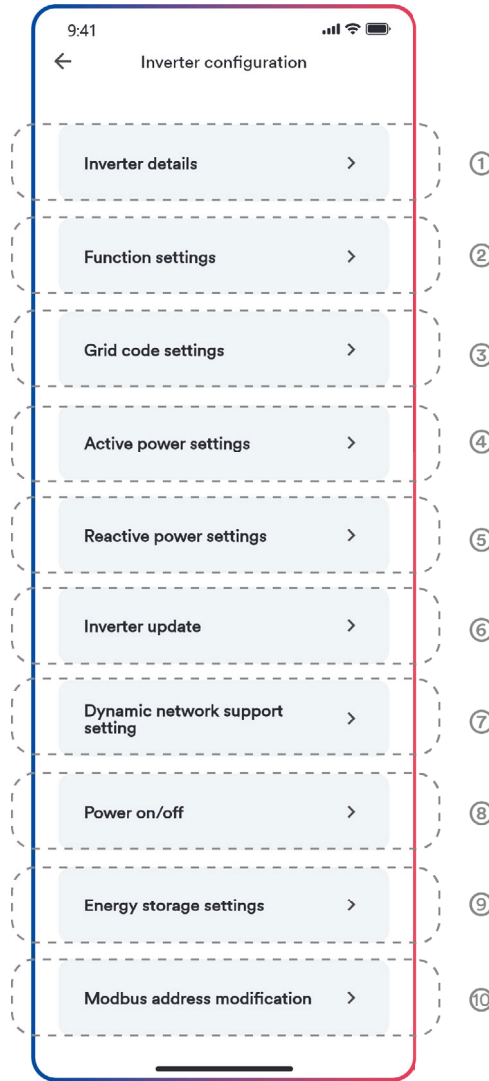

Table description

No.	Function	Description
①	Inverter Details	Show the general information of the inverter. Show the present operation value of the inverter.
②	Function settings	Active the general function. Active some special function.
③	Grid code settings	Choose a safety code. Configure the protection parameters. Configure the start operation parameters and automatic reconnection parameters.
④	Active power settings	Configure the parameters of the P(U) curve. Configure the parameters of the P(f) curve. Configure the parameters of the active power limited. Configure the parameters of the active power increasing and decreasing speed.

⑤	Reactive power settings	Choose the reactive power control mode. Configure the parameters of the Q (U) curve. Configure the parameters of the $\cos \varphi$ (P) curve. Configure the parameters of the fix Q value or fix $\cos \varphi$ value.
⑥	Inverter update	Update the firmware of the inverter and monitor device. Update the safety package.
⑦	Dynamic network support setting	Configure the parameters of the LVRT. Configure the parameters of the HVRT.
⑧	Power on/off	Remote turn on/off the inverter on the App.
⑨	Energy storage settings	Configure the parameters of the Hybrid inverter. Configure the parameters of the battery. Configure the parameters of the generator.
⑩	Modbus address modification	Modify the modbus communication address.

8.5.2 Grid code settings



For the Australia market, the inverter cannot be connected to the grid before the safety related area is set. Please select from Australia Region A/B/C to comply with AS/NZS 4777.2:2020, and contact your local electricity grid operator on which Region to select.

Normally you only need choose the grid code from the support grid code list. The product has fully complied with the standards that are added in the list. If the local grid operator has the other requirement, you can can set the parameter according to the requirement after you get the approval.

Procedure:

Step 1: Tap “Grid code setting” to enter to the next page.

Step 2: Swipe the smartphone screen to choose the right grid code, then tap “Save” and go back the previous page.



Step 1

Step 2

8.5.3 Active power reduction at overfrequency P(f)

There are four modes (Please refer to the following table) can be chosen for this function and many parameters can be configured according to the requirement of the local grid company.

Procedure:

- Step 1:** Tap “Active power settings” to enter to the next page.
- Step 2:** Tap “Overfrequency response settings” to enter to the next page.
- Step 3:** Tap the drop-down menu to choose the mode of this function.
- Step 4:** Configure the parameters and tap “Save”.

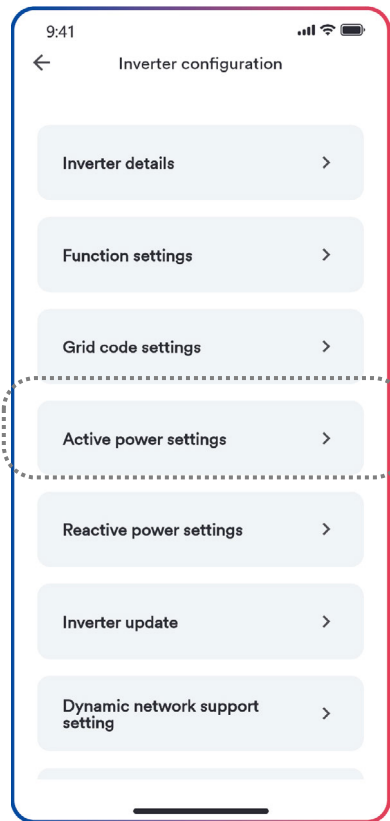

Step 1

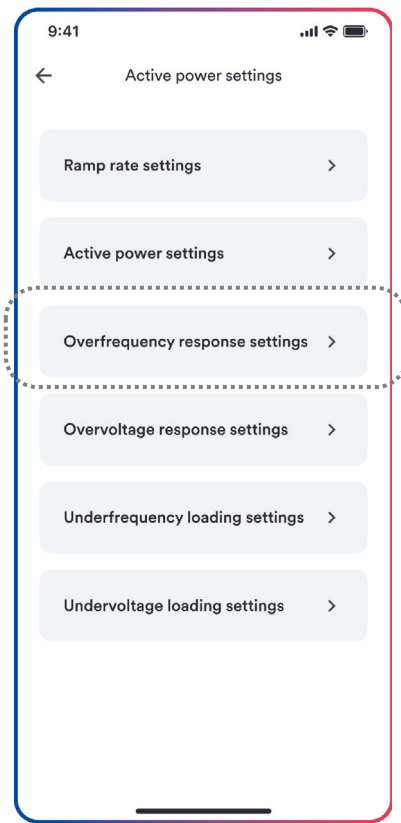

Step 2

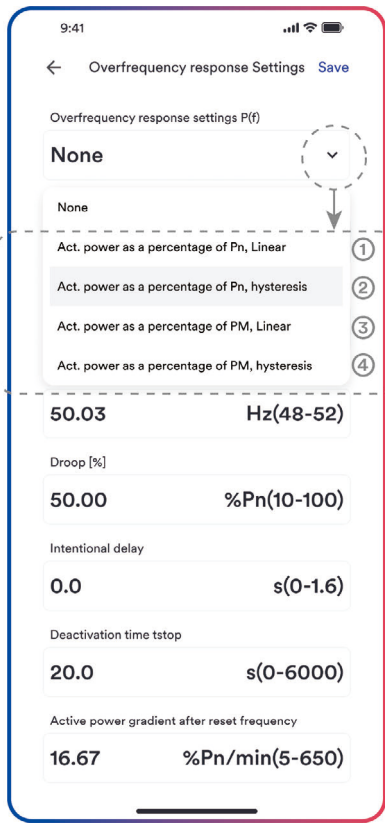

Step 3

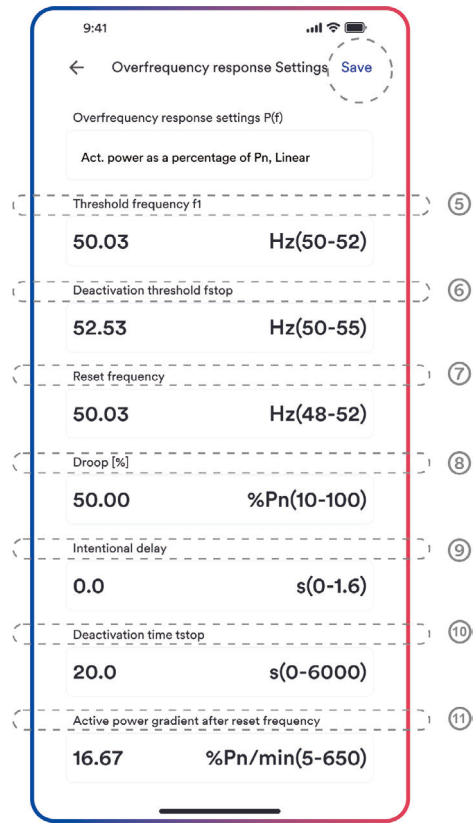

Step 4

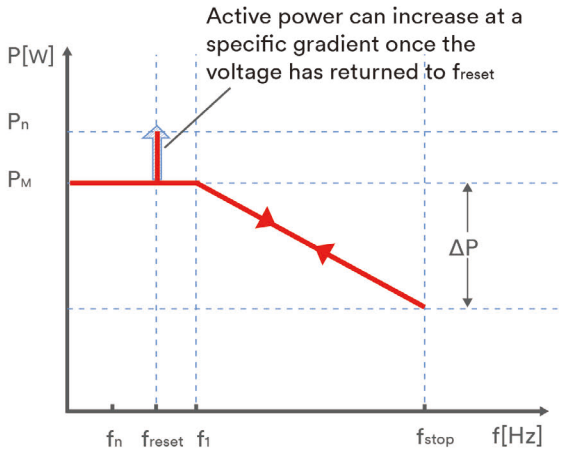

Act. Power as a percentage of P_n , Linear
Act. Power as a percentage of P_m , Linear

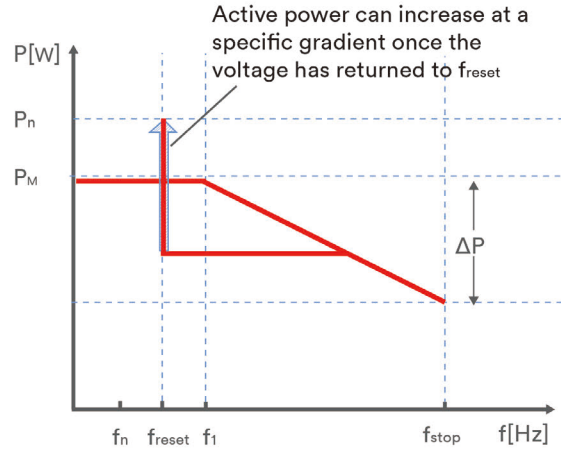

Act. Power as a percentage of P_n , hysteresis
Act. Power as a percentage of P_m , hysteresis

Table description

No.	Name	Description
①	Act. Power as a percentage of P _n , Linear	Droop is defined as the active power as a percentage of P _n . The active power will continuously move up and down the frequency characteristic curve in the frequency range of f ₁ to f _{stop} .
②	Act. Power as a percentage of P _n , hysteresis	Droop is defined as the active power as a percentage of P _n . The active power shall remain at or below the lowest power output level reached in response to the increase in frequency between f ₁ to f _{stop} .
③	Act. Power as a percentage of P _M , Linear	Droop is defined as the active power as a percentage of P _M . The active power will continuously move up and down the frequency characteristic curve in the frequency range of f ₁ to f _{stop} .
④	Act. Power as a percentage of P _M , hysteresis	Droop is defined as the active power as a percentage of P _M . The active power shall remain at or below the lowest power output level reached in response to the increase in frequency between f ₁ to f _{stop} .
⑤	Threshold frequency f ₁	The threshold frequency for activating active power response to overfrequency.
⑥	Deactivation threshold f _{stop}	The threshold frequency for deactivating the active power response to overfrequency or disconnecting the inverter from the grid.
⑦	Reset frequency f _{reset}	The threshold frequency for deactivating the active power response to overfrequency after the frequency reducing.
⑧	Droop ΔP	Reducing the active power in percentage of P _n or P _M when the frequency rise to f _{stop} .
⑨	Intentional delay time	The delay time for activating active power response to overfrequency after the frequency over f ₁ . An intentional delay shall be programmable to adjust the dead time to a value between the intrinsic dead time and 2s.
⑩	Deactivation time t _{stop}	The delay time that the active power can increase after the frequency below f _{reset} .
⑪	Active power gradient	The active power increasing gradient as a percent of P _n per minutes after the frequency reducing to f _{reset} .



Here, the Droop is different from the Droop S in section 3.7.2 of the standard EN 50549-1.

If you want to configure the Droop S, the formula as below should be used to configure.

$$\Delta P = \frac{(f_{stop}-f_1)/f_n}{\text{Droop S}} \times 100$$

8.5.4 Active power reduction at overvoltage P(U)

There are five modes (Please refer to the following table) can be chosen for this function and many parameters can be configured according to the requirement of the local grid company.

Procedure:

- Step 1:** Tap “Active power settings” to enter to the next page.
- Step 2:** Tap “Overfrequency response settings” to enter to the next page.
- Step 3:** Tap the drop-down menu to choose the mode of this function.
- Step 4:** Configure the parameters and tap “Save”.

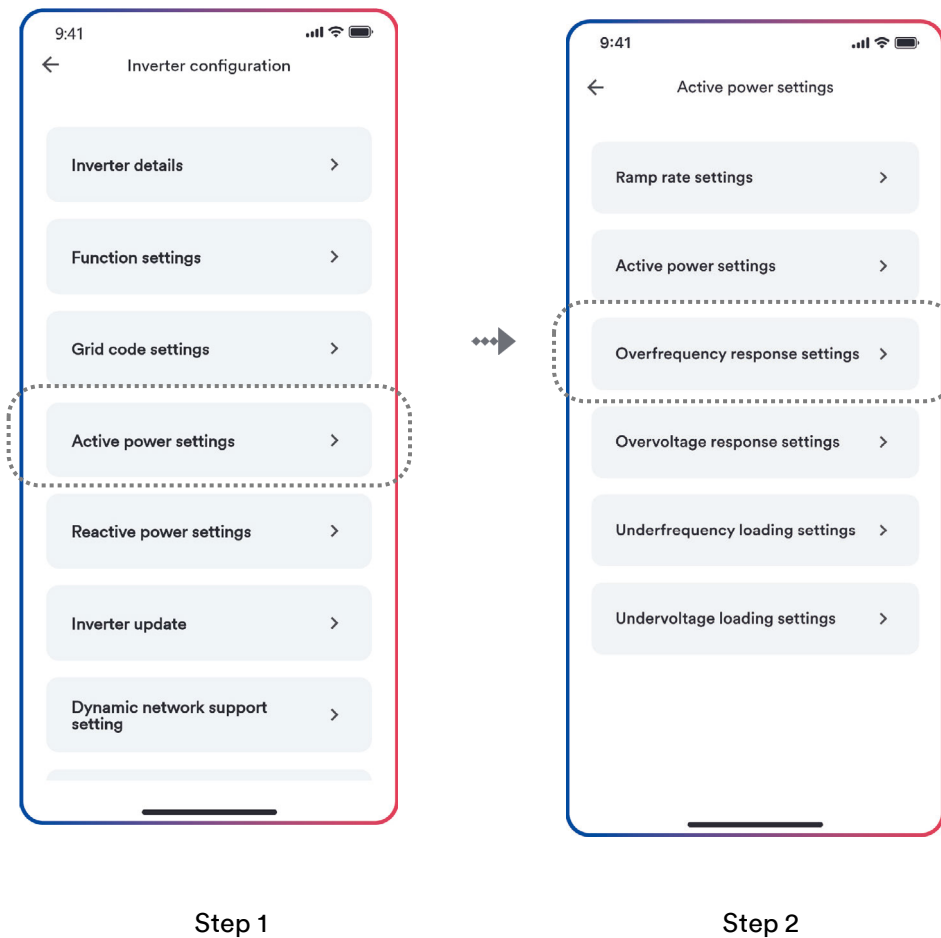

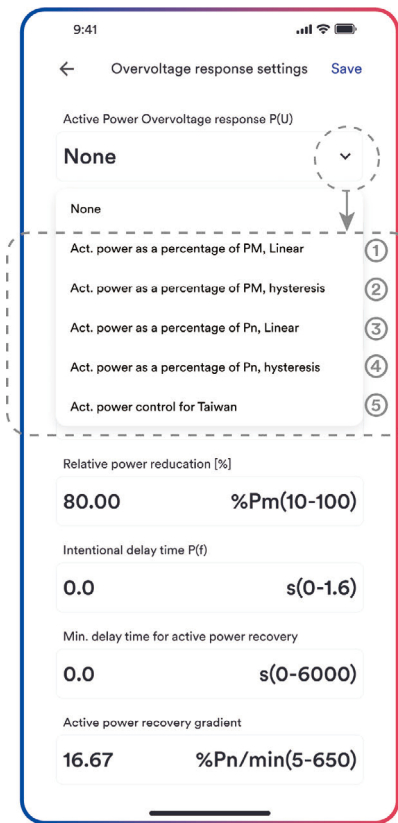

Step 3

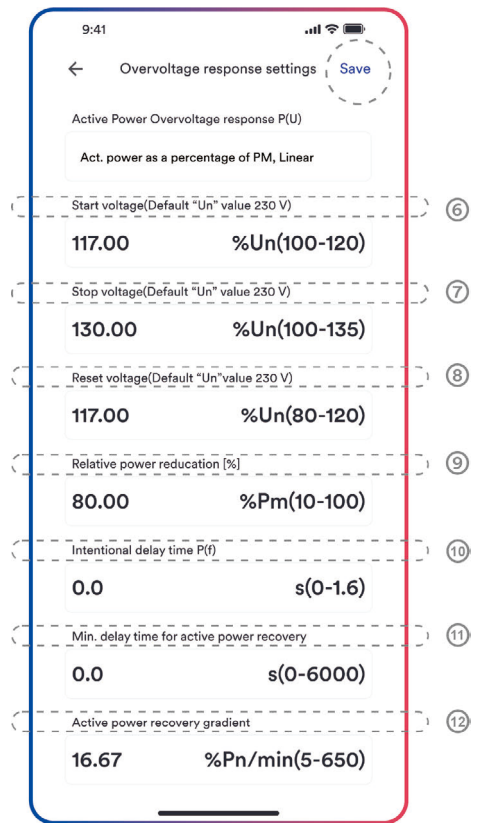

Step 4

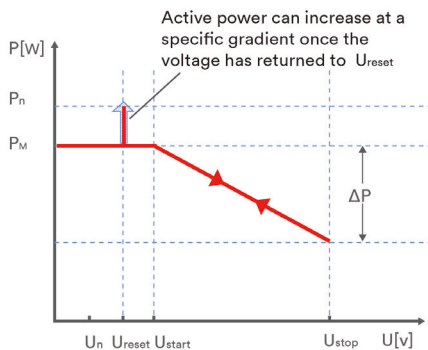

Act. Power as a percentage of P_M , Linear

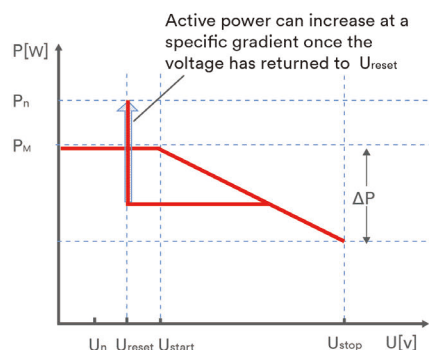

Act. Power as a percentage of P_M , hysteresis

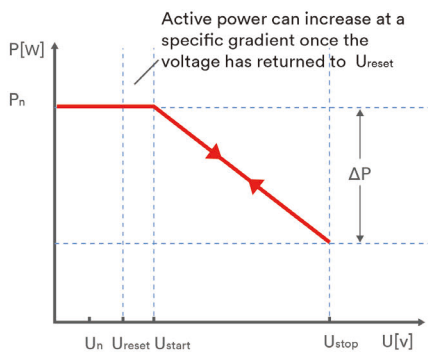

Act. Power as a percentage of P_n , Linear

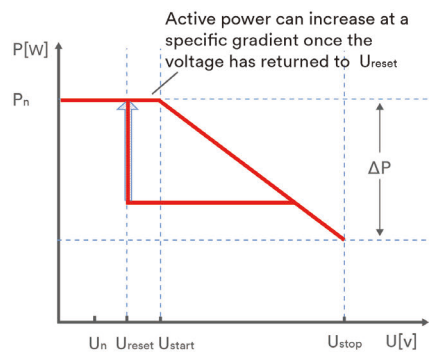

Act. Power as a percentage of P_n , hysteresis

Table description

No.	Name	Description
①	Act. Power as a percentage of P_M , Linear	<p>Droop is defined as the active power as a percentage of P_M.</p> <p>The active power will continuously move up and down the voltage characteristic curve in the voltage range of U_{start} to U_{stop}.</p> <p>The active power reduce from the P_M that is the instantaneous active power at the time of exceeding Start voltage U_{start}.</p>
②	Act. Power as a percentage of P_M , hysteresis	<p>Droop is defined as the active power as a percentage of P_M.</p> <p>The active power shall remain at or below the lowest power output level reached in response to the increase in voltage between U_{start} to U_{stop}.</p> <p>The active power reduce from the P_M that is the instantaneous active power at the time of exceeding Start voltage U_{start}.</p>
③	Act. Power as a percentage of P_N , Linear	<p>Droop is defined as the active power as a percentage of P_N.</p> <p>The active power will continuously move up and down the voltage characteristic curve in the voltage range of U_{start} to U_{stop}.</p> <p>The active power reduce from the rated active power P_n at all time. The active power maybe don't reduce if the limited value of the curve is lower than the instantaneous active power at the time of exceeding Start voltage U_{start}.</p>
④	Act. Power as a percentage of P_N , hysteresis	<p>Droop is defined as the active power as a percentage of P_N.</p> <p>The active power shall remain at or below the lowest power output level reached in response to the increase in the voltage range of U_{start} to U_{stop}.</p> <p>The active power reduce from the rated active power P_n at all time. The active power maybe don't reduce if the limited value of the curve is lower than the instantaneous active power at the time of exceeding Start voltage U_{start}.</p>
⑤	Act. Power control for Taiwan	Special control mode for Chinese Taiwan market.
⑥	Start voltage U_{start}	The threshold voltage for activating active power response to overvoltage.
⑦	Stop voltage U_{stop}	The threshold voltage for deactivating the active power response to overvoltage or disconnecting the inverter from the grid.
⑧	Reset voltage U_{reset}	<p>The threshold voltage for deactivating the active power response to overvoltage after the voltage reducing.</p> <p>Reset voltage does not work in the mode "Act. Power as a percentage of P_N, Linear".</p>
⑨	Droop ΔP	Reducing the active power in percentage of P_N or P_M when the voltage rise to U_{stop} .
⑩	Intentional delay time	The delay time for activating active power response to overvoltage after the voltage over U_{start} . An intentional delay shall be programmable to adjust the dead time to a value between the intrinsic dead time and 2s.
⑪	Deactivation time t_{stop}	The delay time that the active power can increase after the voltage below U_{reset} .
⑫	Active power gradient	The active power increasing gradient as a percent of P_n per minutes after the frequency reducing to f_{reset} .

8.5.5 Cosφ(P) curve configuration

The power related control mode $\cos\phi(P)$ controls the $\cos\phi$ of the output as a function of the active power output.

There are four coordinate points that can be configured. The coordinate points are the active power as a percentage of P_n and the displacement factor $\cos\phi$.

Procedure:

Step 1: Tap “Reactive power settings” to enter to the next page.

Step 2: Tap “Enable reactive power” to choose the reactive power control mode and tap the left arrow to go back.

Step 3: Tap “Cosφ(P) curve settings” to enter to the next page.

Step 4: Configure the parameters and tap “Save”.

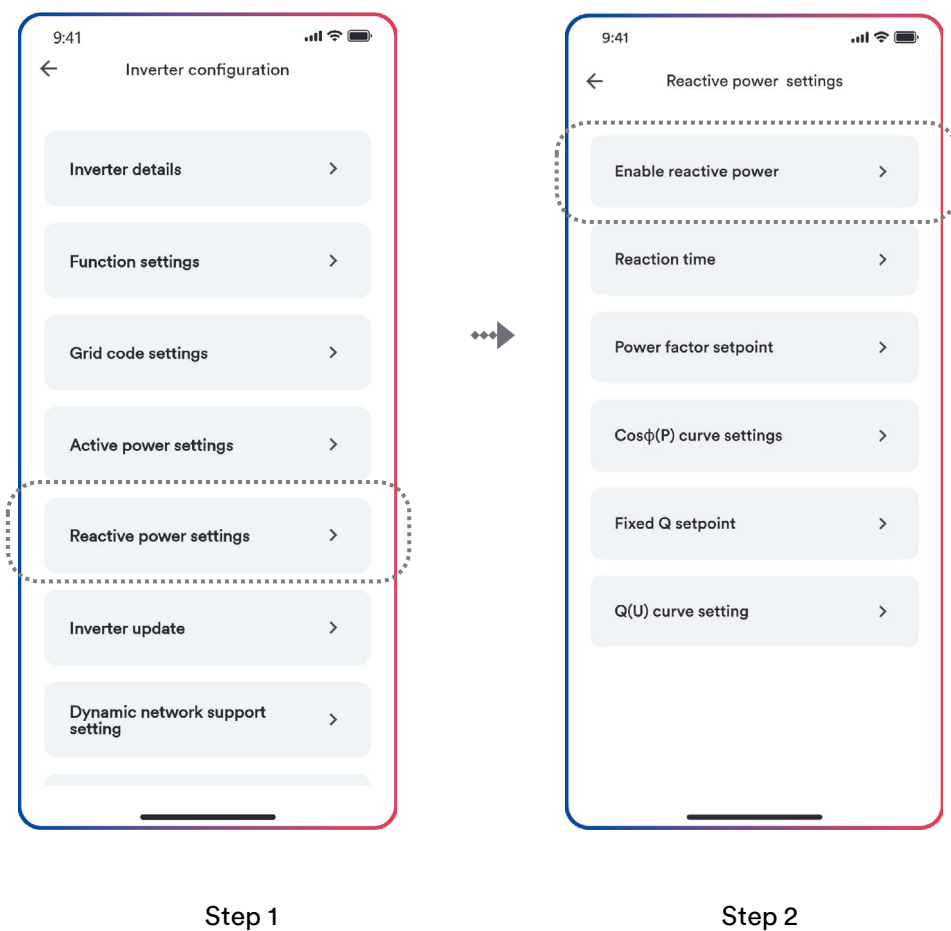

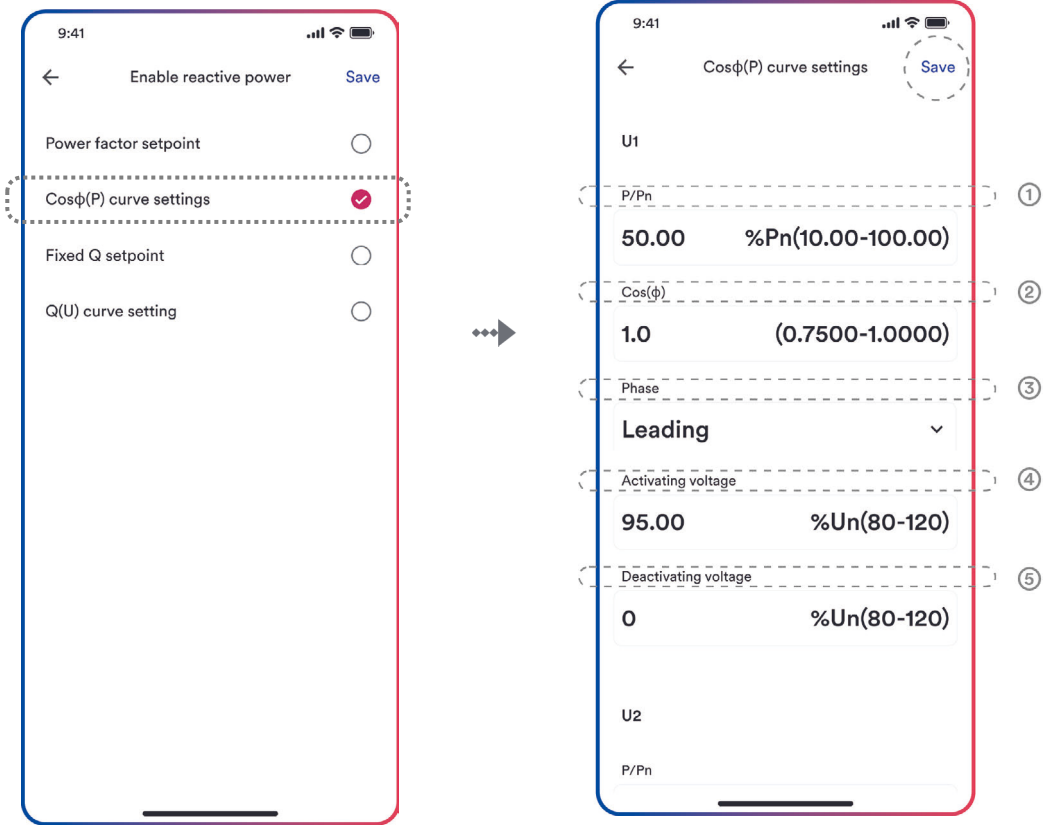

Step 3

Step 4

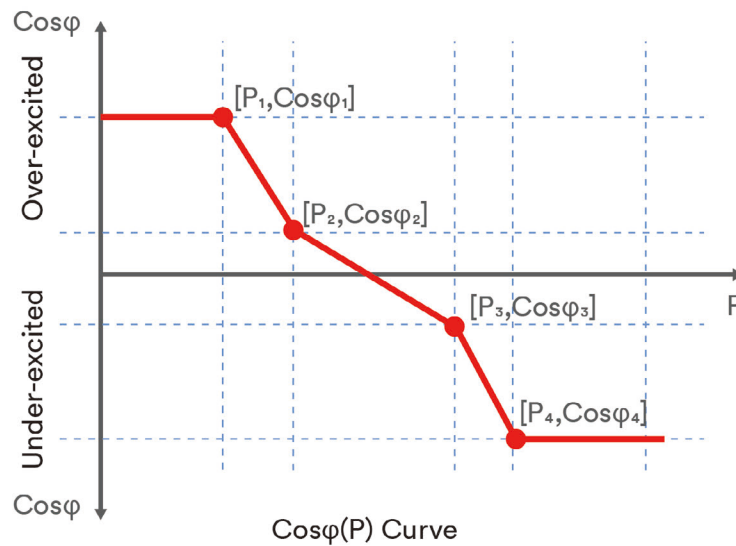

Table description

No.	Parameter	Description
①	P/P _n	The active power as a percentage of P _N .
②	Cosφ	The displacement factor that is cosine of the phase angle between the fundamental components of the line to neutral point voltage and the respective current.
③	Phase	Choose the over-excited or under-excited.

④	Activating voltage	The lock-in voltage value that enables the automatic reactive power delivery mode. Activation threshold as a percentage of U_n corresponds to 'lock-in' voltage.
⑤	Deactivating voltage	The lock-out voltage value that disables the automatic reactive power delivery mode. Deactivation threshold as a percentage of U_n corresponds to 'lock-out' voltage.



Some grid companies may require two voltage thresholds as a percentage of U_n to activate or deactivate the function. The voltage thresholds normally call 'lock-in' and 'lock-out' voltage.

8.5.6 Q(U) curve configuration

The voltage related control mode Q(U) controls the reactive power output as a function of the voltage.

There are four coordinate points that can be configured. The coordinate points are the voltage as a percentage of U_n and the reactive power as a percentage of P_n .

Procedure:

- Step 1:** Tap "Reactive power settings" to enter to the next page.
- Step 2:** Tap "Enable reactive power" to choose the reactive power control mode and tap the left arrow to go back.
- Step 3:** Tap "Q(U) curve settings" to enter to the next page.
- Step 4:** Configure the parameters and tap "Save".



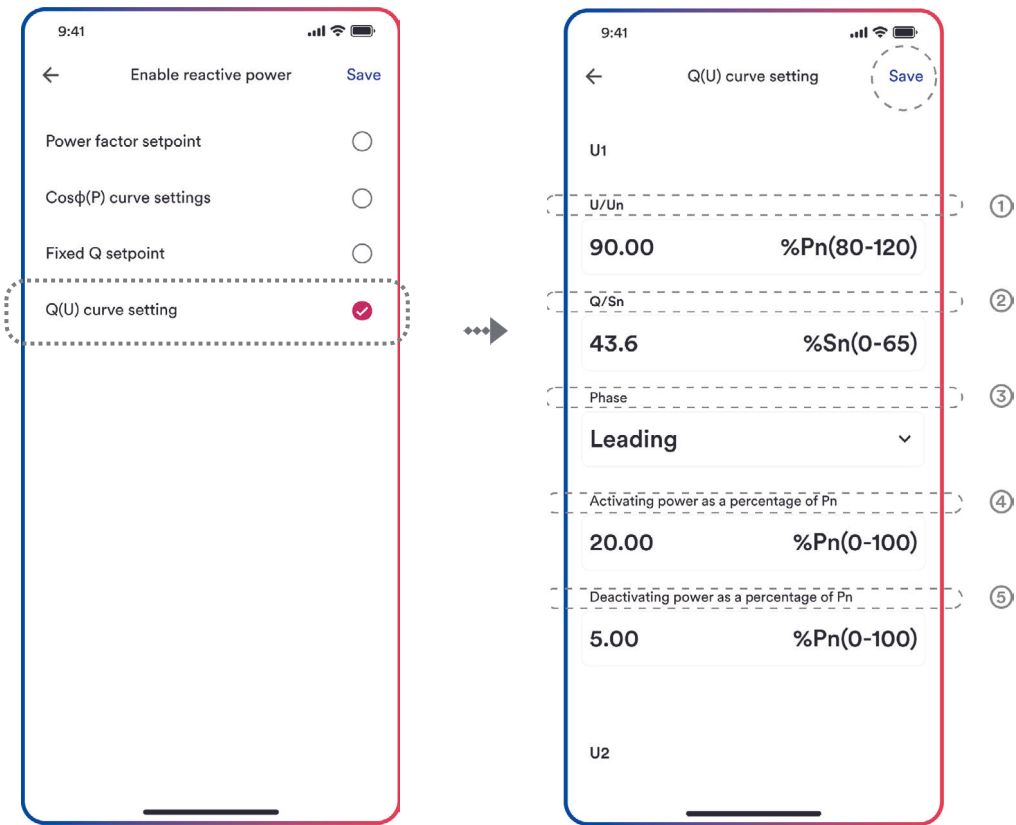

Step 3

Step 4

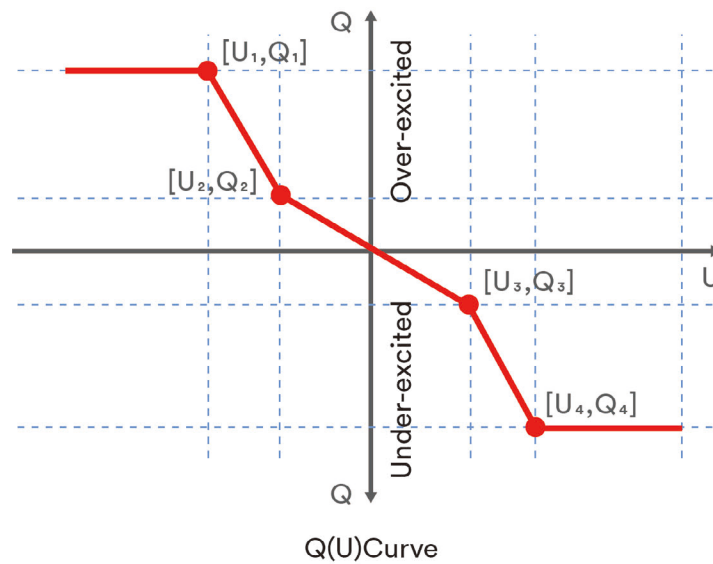

Table description

No.	Name	Description
①	U/U_n	The voltage as a percentage of U_n .
②	Q/P_n	The reactive power as a percentage of P_n .
③	Phase	Choose the over-excited or under-excited.

④	Activating power as a percentage of P_n	The lock-in active power value that enables the automatic reactive power delivery mode. Activation threshold as a percentage of P_n corresponds to 'lock-in' power.
⑤	Deactivating power as a percentage of P_n	The lock-out active power value that disables the automatic reactive power delivery mode. Deactivation threshold as a percentage of P_n corresponds to 'lock-out' power.



Some grid companies maybe requires two active power thresholds as a percentage of P_n to activate or deactivate the function. The active power thresholds normally call 'lock-in' and 'lock-out' active power.

8.5.7 Generator settings

This function is mainly used to set the function of the generator port. When the function of the generator port is enabled, there are two function modes to choose from, one is the generator mode and the other is the smart load mode. Only one of the two can be selected. Customers can choose according to their actual needs, and after confirming the mode, they also need to set the parameters in the mode.

Procedure:

Step 1: Tap “Enerage storage settings” to enter to the next page.

Step 2: Tap “Generator settings ” to enter to the next page.

Step 3: Tap the button next to “Generator Enable” to enable the generator port function ,than Tap “Generator settings ” to enter to the next page.

Step 4: Choose either “Generator access” or “Smart laod access” based on the actual application situation, with only one option available, Configure the parameters and tap “Save”.

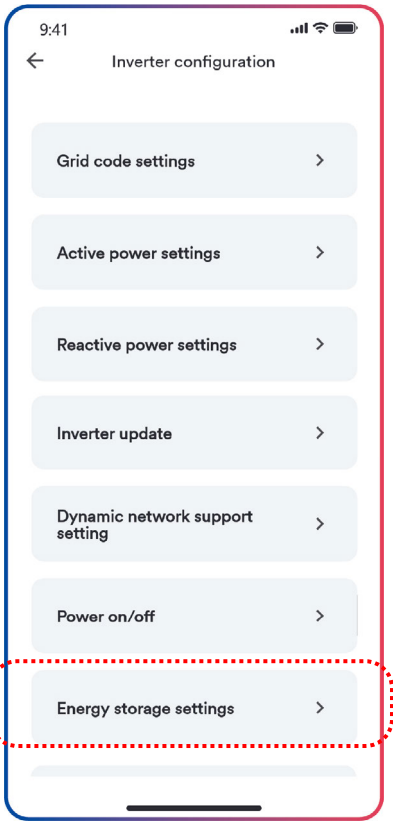

Step 1

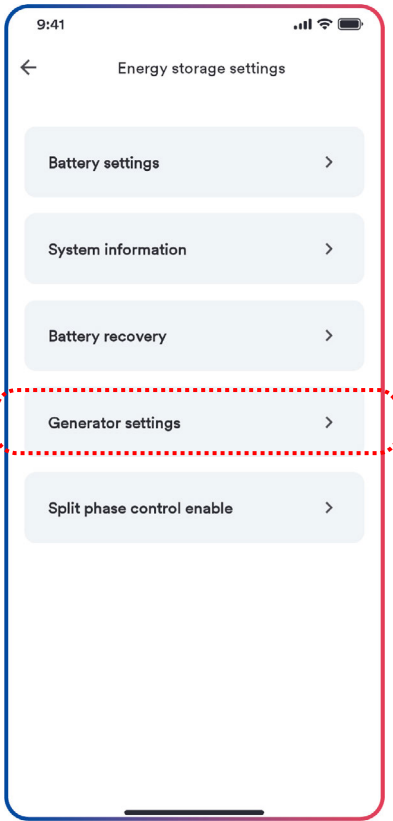

Step 2

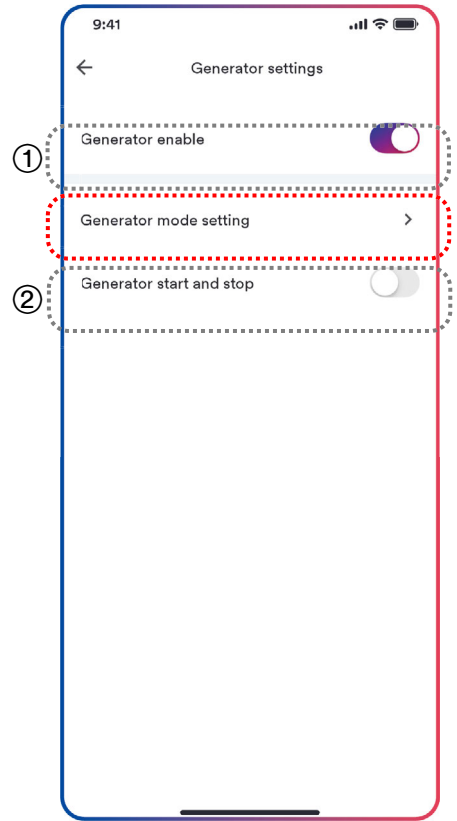

Step 3

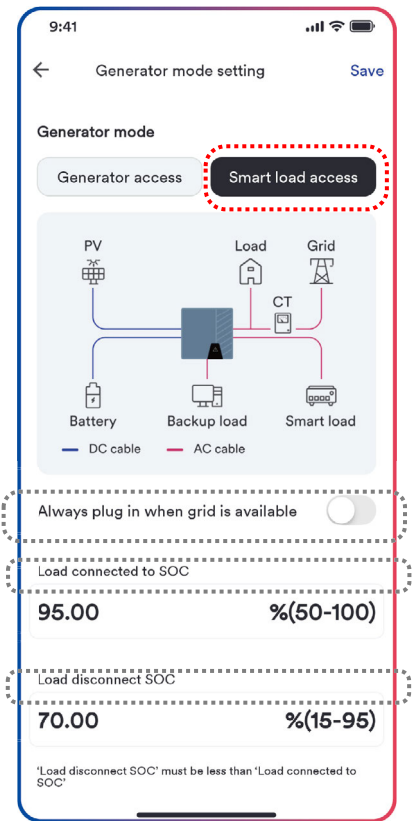
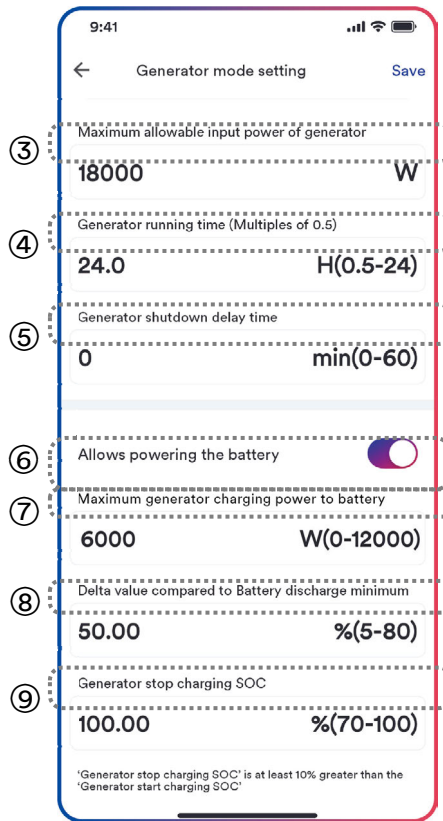
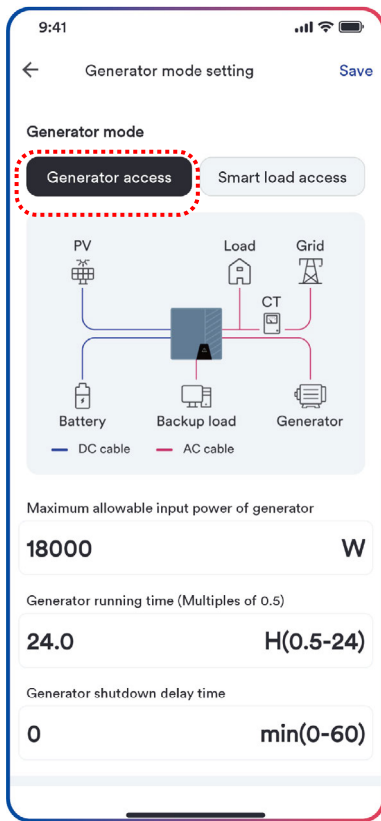

Step 4

Table description

No.	Name	Description
①	Generator enable	Used to enable the generator port function.
②	Generator start and stop	Normally open relay that closes when the Generator Start signal state is active. Remote control of generator start and stop using dry contact signal.
③	Maximum allowable input power of generator	allowed Max. power from diesel generator.
④	Generator running time	Generator can run in one day, when time is up, the Generator will be turned off.
⑤	Generator shutdown delay time	It indicates the delay time of the Generator to shut down after it has reached the running time.
⑥	Allows powering the battery	uses the generator input of the system to charge battery bank from an attached generator
⑦	Maximum generator charging power to battery	The maximum power allowed for the generator to charge the battery.
⑧	Delta value compared to Battery discharge minimum	When the SOC value of the battery is less than the sum of the set value and the minimum discharge value of the battery, the generator will allow the battery to be charged.
⑨	Generator stop charging SOC	When the SOC value of the battery exceeds the set value, the generator stops charging the battery.

⑩	Always plug in when grid is available	When this function is enabled, the smart load will switch on when the grid is present.
⑪	Load connect SOC	When the SOC value of the battery exceeds the set value, the smart load will be connected
⑫	Load disconnect SOC	When the SOC value of the battery is less than the set value, the smart load will disconnect



The generator access and Smart load access can only be selected as either. Before starting the inverter, it is necessary to confirm whether the selected mode matches the actual working conditions. When the mode is set incorrectly, please change it while shutting down. Switching modes during operation will cause the inverter to alarm and shut down.

When setting the SOC value of battery charging in generator setup page, it should be noted that the actual set value is the increment between the required value and the minimum value of battery discharge.

Generator stop charging SOC is at least 10% greater than then Generator start charging SOC.

Load disconnected SOC must be less than load connected to SOC.

The parameter of the maximum generator charging power to battery refers to the maximum power that the generator can output for battery charging, rather than the actual charging power of the battery

8.5.8 Asymmetrical power output

If user enable **Asymmetrical power output**, the inverter will asynchronous output. Which means that in self-consumption mode with unbalance three phase load, the inverter correspondingly output three-phase imbalance unless load power is too high (above 1/3 rate power) to consume grid power.

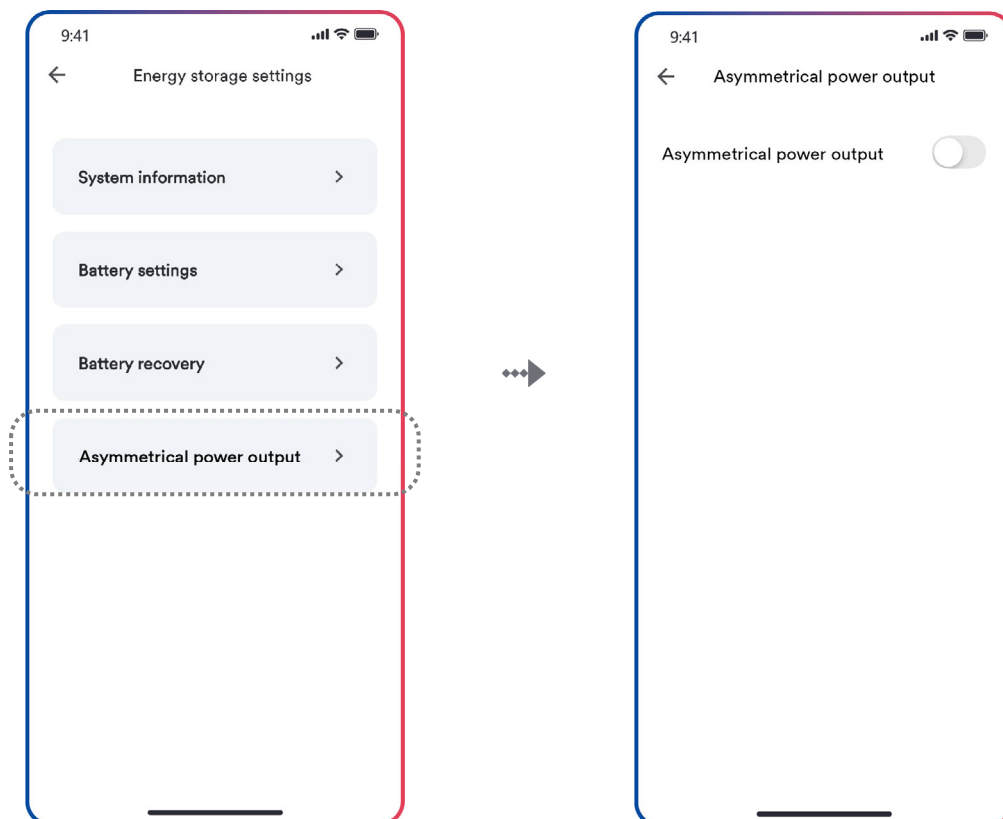



Before enable **Asymmetrical power output**, make sure the phase sequence of CT or meter is consistent with grid and inverter. otherwise inverter will work abnormal.

If Asymmetrical power output is enable, the export power control can chose Lower phase power. in this mode , every phase(L1,L2,L3) will not export power to grid even if there is a value in export power limit setpoint.

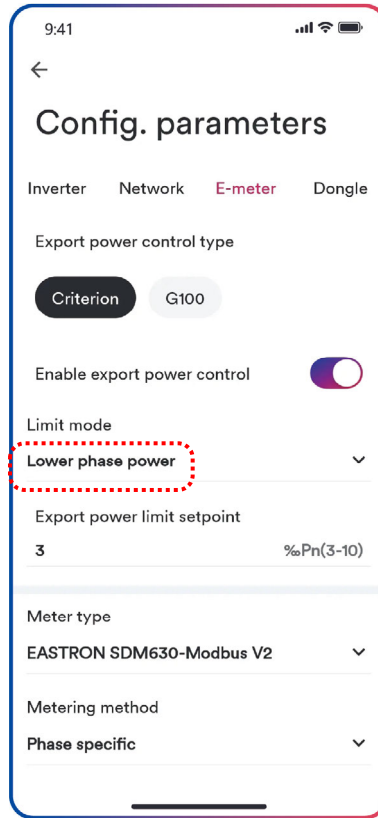

8.5.9 Export all the setting parameters of the inverter

The APP has the function of exporting all the setting parameters in the inverter. This feature enables customers to have a clear understanding of the parameters set in the inverter at a glance, without having to repeatedly enter and exit the setting interface to view the parameters.

Procedure:

- Step 1:** Tap “Inverter details” to enter to the next page.
- Step 2:** Click the icon in the upper right corner to pop up the Signature interface.
- Step 3:** When the user completes the signature and clicks“ Confirm”, they can view all the parameters set in the inverter.
- Step 4:** Click the icon in the upper right corner to download and view these data.

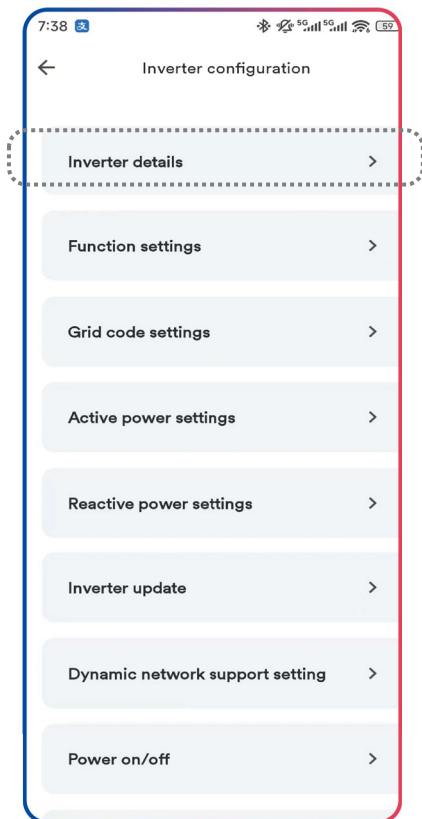

Step 1

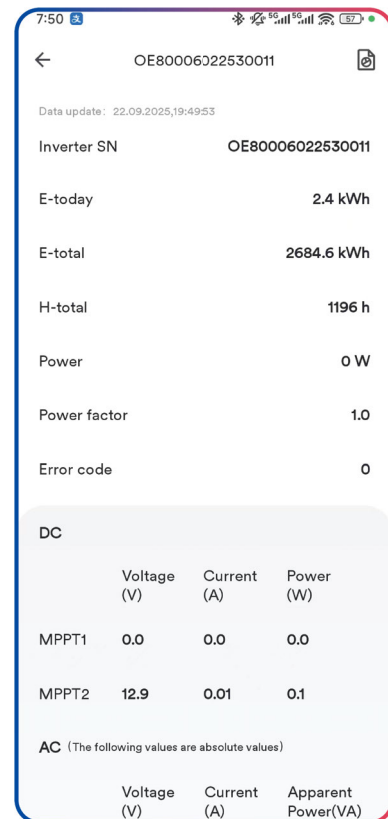

Step 2

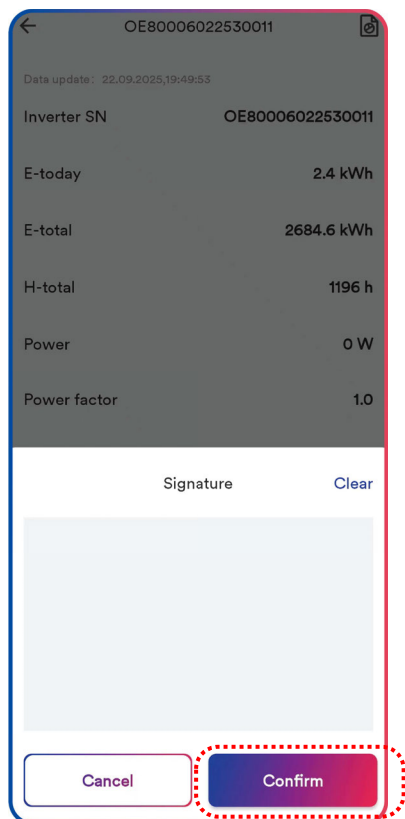

Step 3

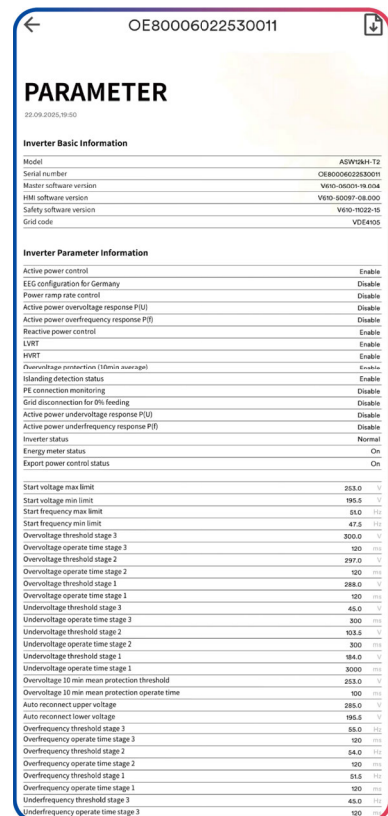

Step 4

8.6 Parallel parameter setting and using

The product is shipped based to the single inverter configuration. Parallel application requires reset the parameters. After the parallel system assembly is completed, the steps for setting parameters are as follows:

Step 1: Refer to Chapters 8.1-8.5 to download and install the APP, configure the power station, and connect to the Internet.

Step 2: Tap “Create or modify a plant”, then the camera of the mobile automatically turns on, and scan the QR code of the Ai-dongle to enter the next screen, tap “Create new plant” to the next screen.

Step 3: Tap “Scan inverter”, the serial numbers of all inverters in the parallel system will be scanned out, and the APP will automatically set the inverter with stick as the master inverter, and the other inverters as slave inverter. If any are missing, confirm the wiring and scan again. If the EPS side in parallel, the **Multi machine EPS in parallel** in APP must be turned on after scan out, it can be setup only in off state.

Step 4: Tap “Configure parameters”, then the camera of the mobile automatically turns on, and scan the QR code of the Ai-dongle to enter the next screen, choose the inveter setting parameters.



- Power on the PV of all parallel inverters, but do not power on the battery and AC.
- When the parallel wiring is completed, the battery and AC power cannot be connected before the parallel parameters are setup. Unless remote shutdown is set for each inverter through the APP, the master inverter can be turned on again after setting up the parallel system.

For parallel system, all inverters are setup through the master inverter page. After setting the master inverter parameters, all slaver inverters will set this parameter. For example, if master inverter set the output power to 1KW in a system with four inverters, the output power of the entire system is 1KW*4. When **Multi machine EPS in parallel** is enable, the total EPS current and power only display in master inverter. The battery information can be read in their own list.

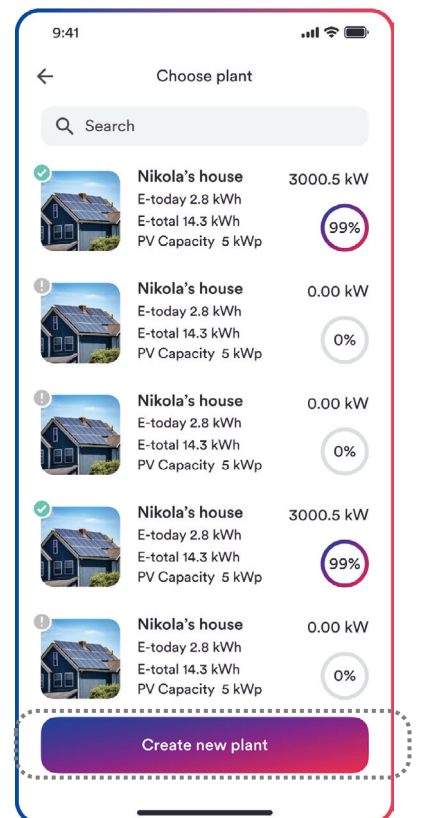

Step 2

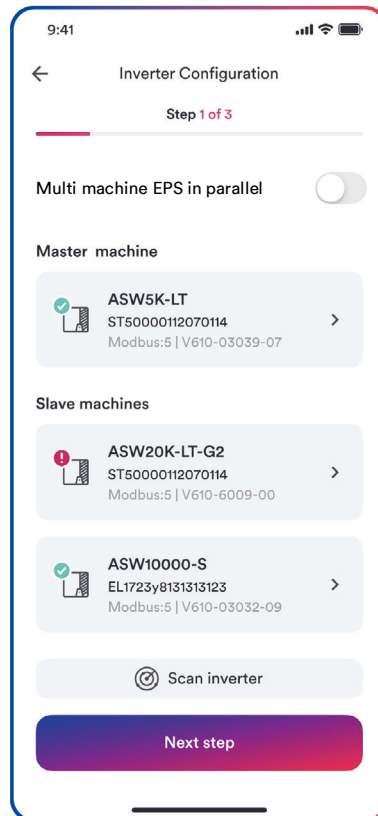
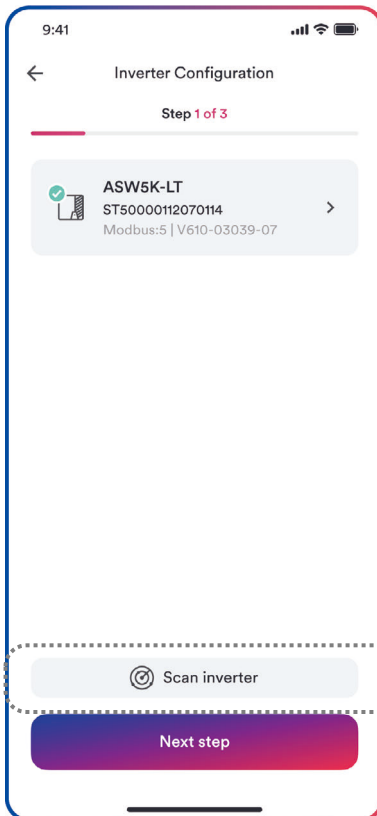

Step 3

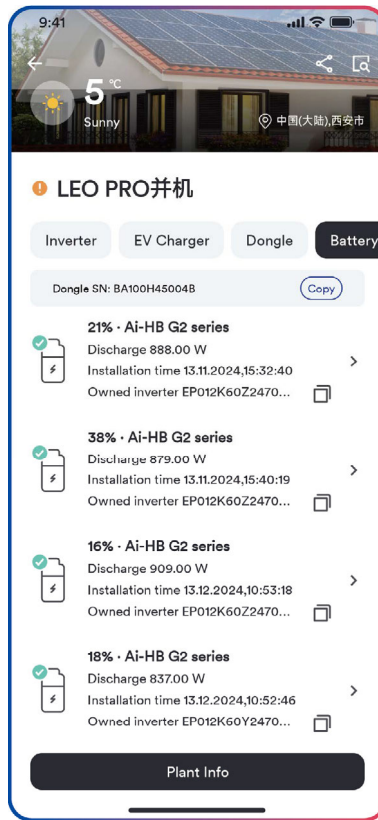

Step 3

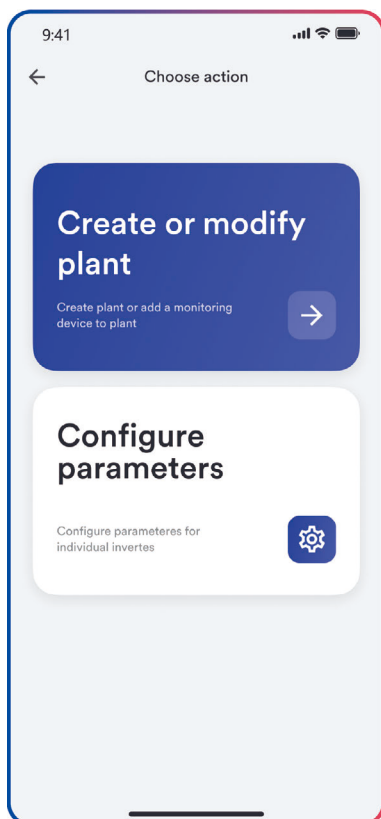

Step 4

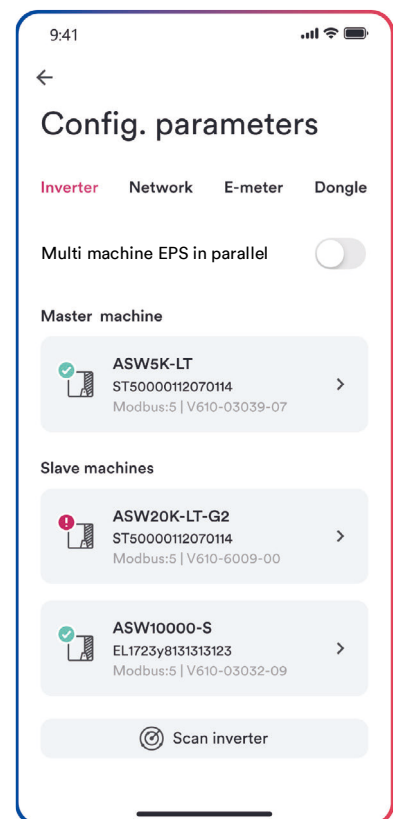

8.7 Activated Arc-fault Circuit Interrupter (AFCI)

The Solplanet App can establish a communication connection to the inverter via WLAN, thereby achieving near-end maintenance on the inverter. The Arc-fault Circuit Interrupter (AFCI) function can be activated on the Solplanet App.

Both the "Business user" and "End user" user groups can activate the AFCI function during PV plant commissioning. However, only the "Business user" can activate the AFCI function after the PV plant is operating normally.

Procedure:

Step 1: Refer to "8.4 Create a plant" to enter the "Inverter Configuration" screen.

Step 2: Tap "Function Settings" to enter the next screen, and tap "AFCI" to enter the next screen.

Step 3: Tap the switch "Enable AFCI", then the automatic self-test function will be performed.

Step 4: The "Alarm detection sensitivity" and "Reconnection method" can be chosen. If "Low sensitivity" is chosen, the inverter will automatically analyze and determine whether the current fault is a genuine arc fault, and the error code will be sent only for genuine arc faults. If "Normal sensitivity" is chosen, the error code will be sent immediately.



When the AFCI function is enabled for the first time, a self-test will be performed automatically before operation.

Additionally, the self-test will be performed once every 24 hours after the initial operation.

If manual reconnection is chosen, the inverter will not restart after detecting an arc until the fault is cleared manually.

If automatic reconnection is chosen, the inverter will restart with a minimum delay time of 5 minutes after detecting an arc.

When interrupting the fifth time within a 24 h period, the inverter is only allowed to be reset manually.

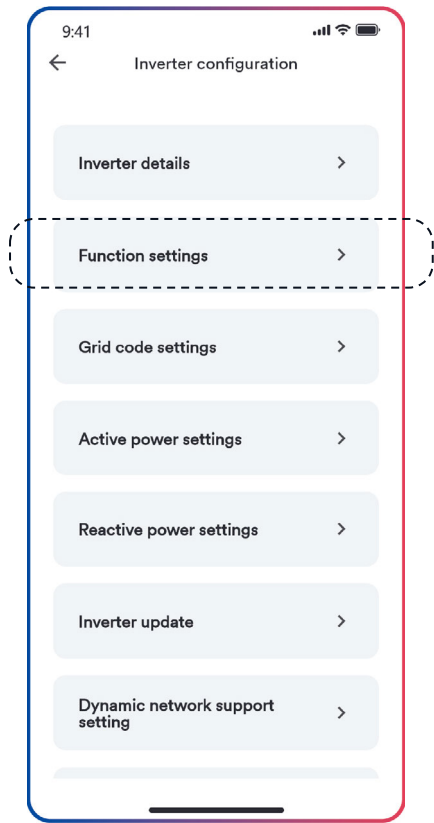

Step 1

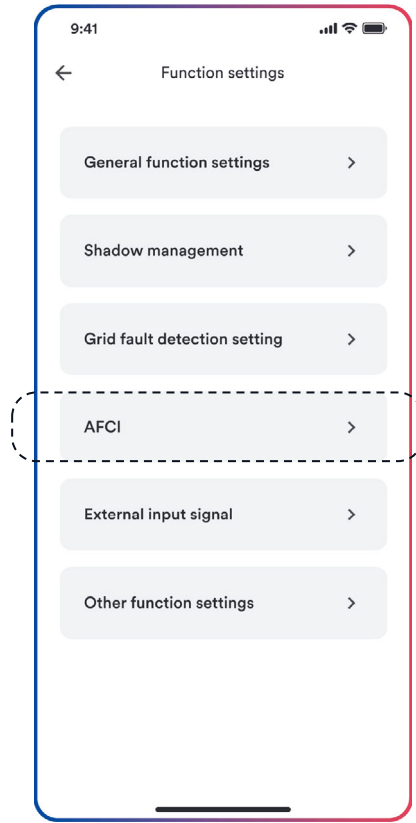

Step 2

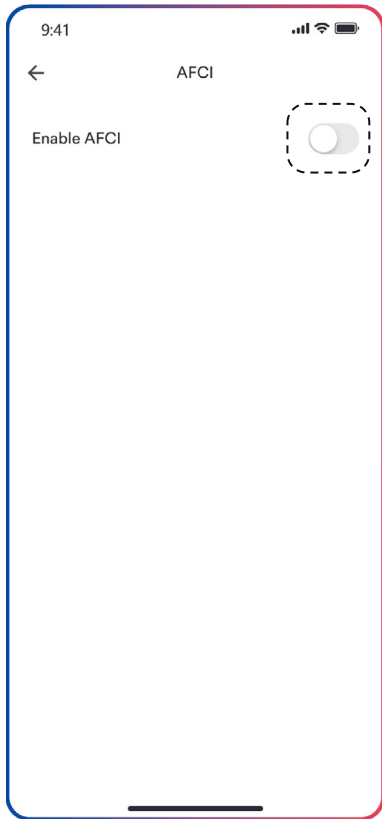

Step 3

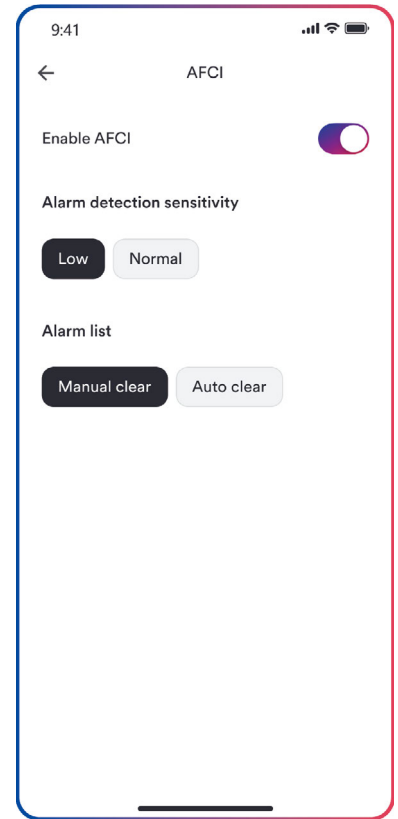
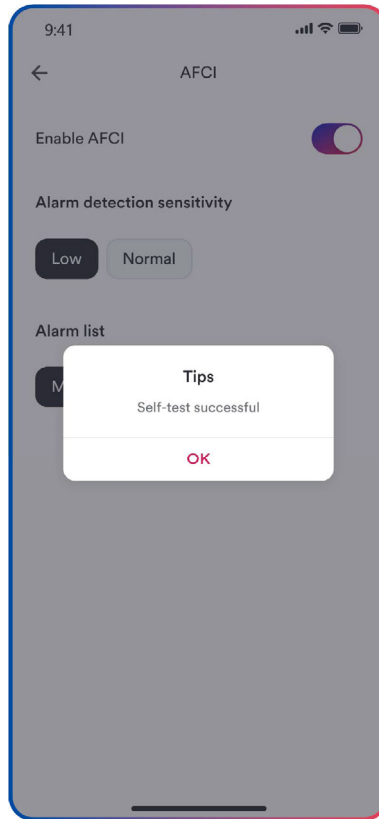

Step 4

8.8 Digital output and Heat pump settings

In the Digital output menu, you can configure the two Digital output interfaces (DO1/DO2). The Heat pump control parameters can be configured in the Heat pump settings. The two items are associated, and you should start with the Digital output interfaces before the Heat pump settings.

Procedure:

Step 1: Refer to “8.4 Create a plant” to enter the “Inverter Configuration” screen.

Step 2: Tap “Function Setting” to enter the next screen , and tap “Digital output” to enter the next screen.

Step 3: Configuring the DO1/DO2 : The DO1 and DO2 can be configured on the Digital output page. Each DO can be configured as “ Not Used ”, “ PV Ready Heat Pump ”, “ SG Ready Pump ” ,“ Diesel generator”. The user can select the appropriate option according to the needs. The Diesel generator control signal is configured to DO1 by default. Diesel generator control is not supported in SG Ready mode . Tap “Save” when the configuration is complete, Then a Tip window will pop up, tap “Exit” to exit, tap “Yes” will jump to the Heat pump settings page.

Step 4: Heat pump Settings: tap “Yes” in the previous step to enter the Heat pump Settings page, You can also directly tap Heat pump Settings to enter the Heat pump Settings page, On this page, you can set the control parameters of the heat pump. Tap “Save” when the Settings are complete . Refer to the following table description for the meanings of the Settings.

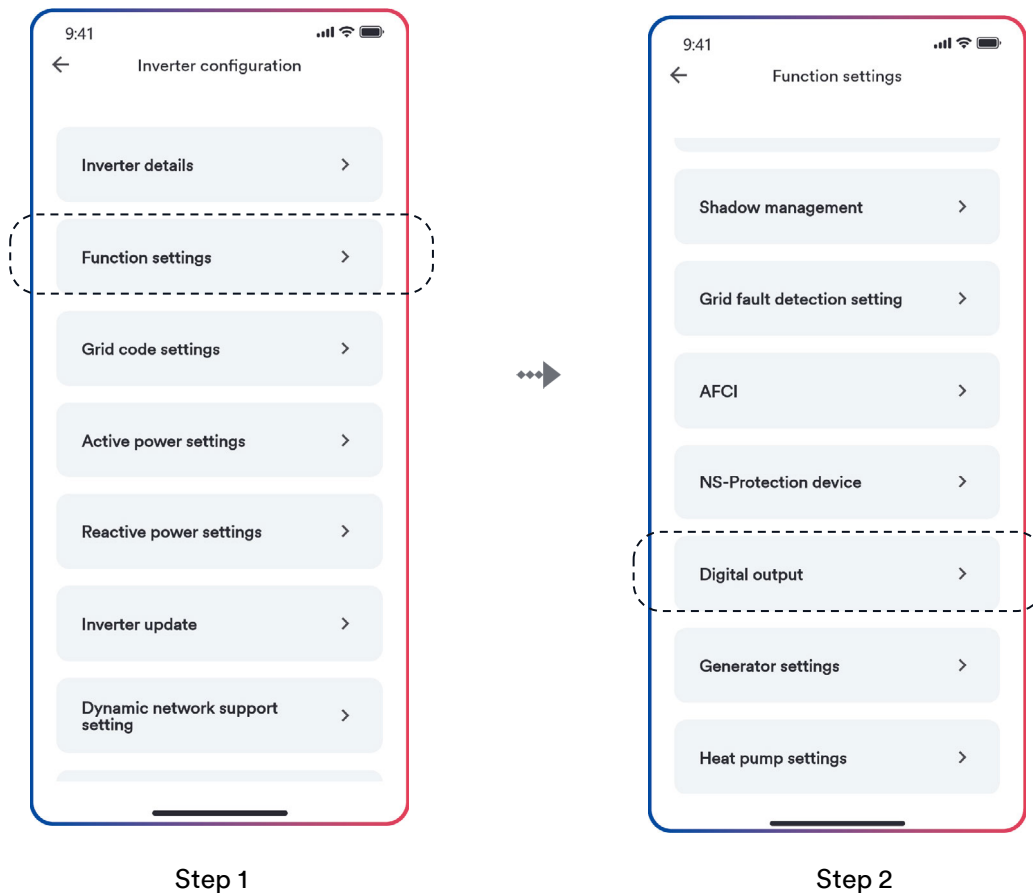

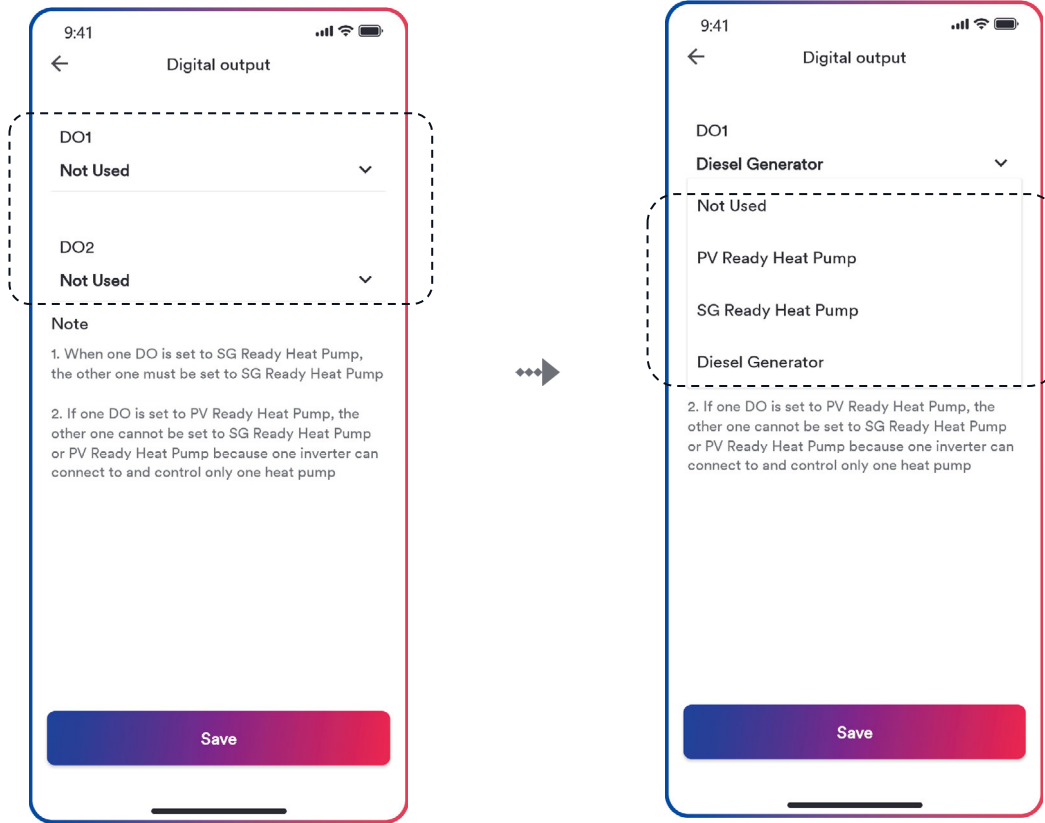

Step 3

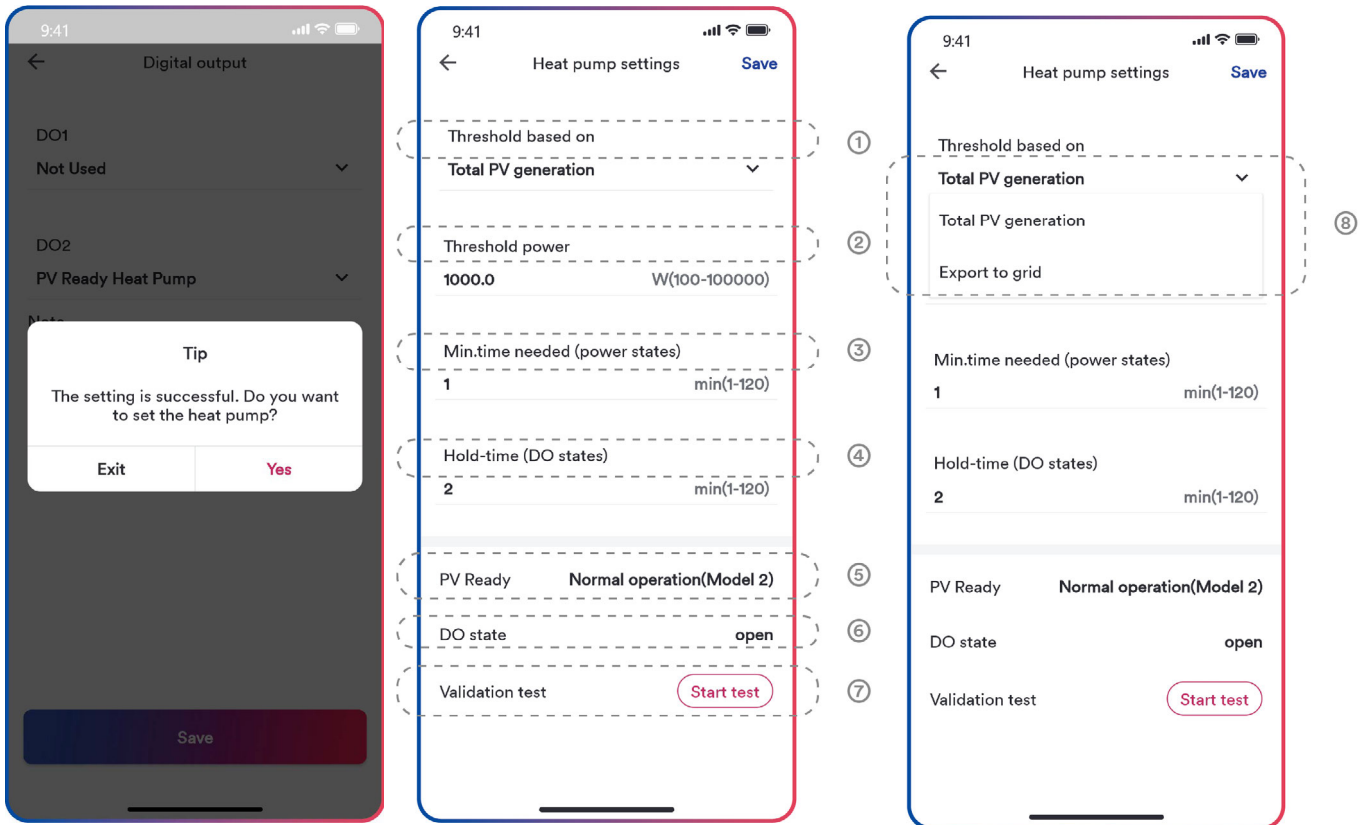

Step 3

Step 4

No.	Function	Description
①、⑧	Threshold based on	The inverter can control the operation mode of a compatible heat pump according to the defined threshold . There are two options in the drop-down menu: Total PV generation and Export to grid. The first uses the AC output power of the inverter as the basis for the threshold whereas the second uses the AC power output to the grid using data from the main meter. Note that the battery is prioritized higher than the heat pump.
②	Threshold power	The power threshold that regulates the operating state of the compatible heat pump. When the defined power level is fulfilled throughout the defined “ Min. time needed ” the DO state is changed to signal the heat pump to start if possible. Likewise, once the defined power level is no longer fulfilled throughout the “ Min. time needed ” the DO state is changed to signal the heat pump to stop if possible. Note that the Hold-time is also respected.
③	Min. time needed (Power states)	The Min. time needed defines for how long the defined power level must be available or unavailable to switch the DO state(s).
④	Hold-time (DO states)	The Hold-time defines for how long a relay state must be kept as a minimum after a change.
⑤	Heat pump status display	The display of the working state of the heat pump. There are two working states, one is Normal operation (Mode 2) and the other is Encouraged operation (Mode 3).
⑥	DO state	The DO states show if they are open or closed.
⑦	Validation test	The validation test function can be used to for 10 minutes temporarily set the DOs to trigger the heat pump to start, if possible. This can be used if conditions are not currently fulfilled to trigger the heat pump. This is useful to validate the wiring and settings in the heat pump itself. The validation test can be manually stopped and otherwise it will automatically cease and return to normal logic after 10 minutes.

8.9 AC-couple

For the AC couple , Solplanet hybrid inverter can work with third-party PV inverter or other devices like EV charger, a second meter may be needed to monitor the power of PV inverter or other devices.(If the PV inverter is Solplanet inverter, there will no need to install the second meter, just add the communication stick to the same power plant). A dual-CT meter Eastron SEM3-M-2L is proposed for the AC-couple. The following is the system single-line diagram. the first group of CT installs at the grid connection point and arrows to Hybrid inverter, the second group of CT installs at the PV inverter side and arrows to Grid.

For already installed inverters, when a smart meter is installed, AC coupling can also be achieved by installing a CT on the PV inverter and connecting it to the CT interface of the inverter communication board.

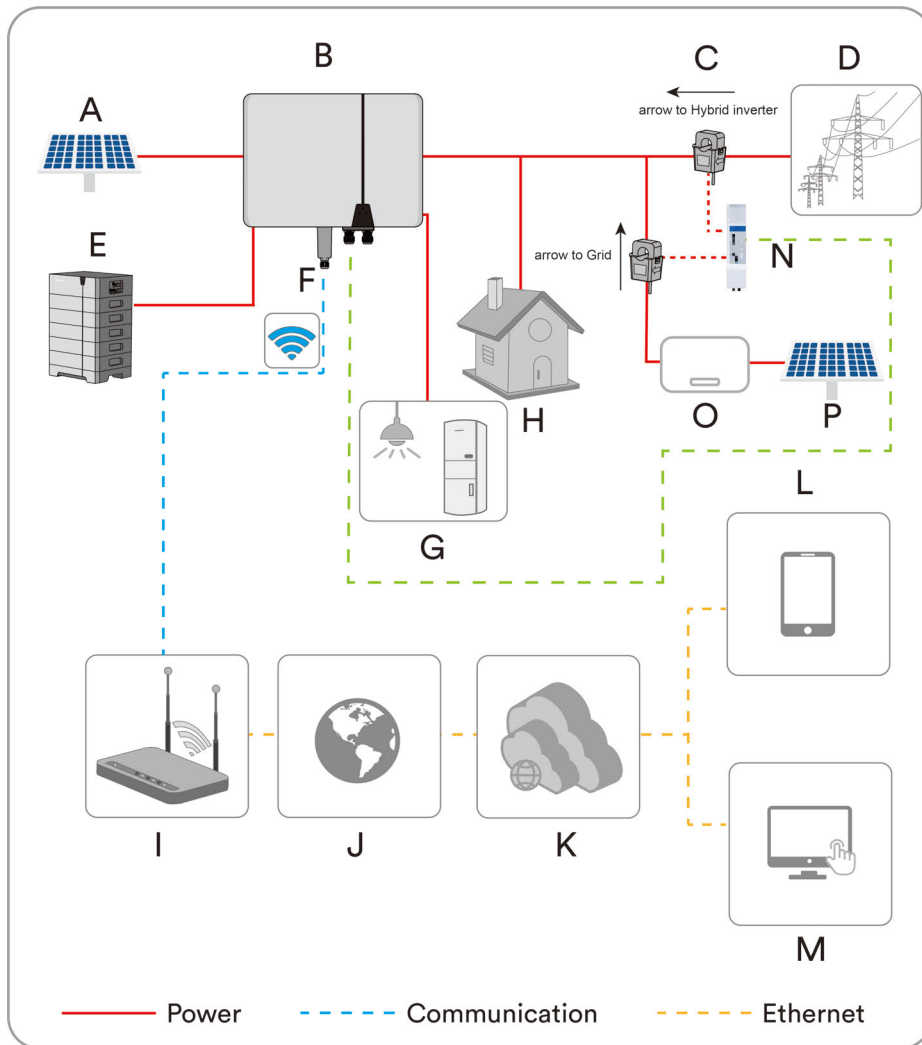

After wiring completion, please check the CT phase sequence and arrow direction, and make sure L1,L2,L3,N cables have been connected to the correct positions.

If PV inverter is single phase inverter, just connect one of CTs to the inverter and make sure the CT phase is the same as the phase of PV inverter.

After meter installation, please select 'EASTRON SEM3-M-2L-CT1' of meter type on the APP, and the second meter will be automatically selected to 'EASTRON SEM3-M-2L-CT2', please choose 'Grid connected inverter' for meter control type, and click Save then you will see the two groups of meter information.

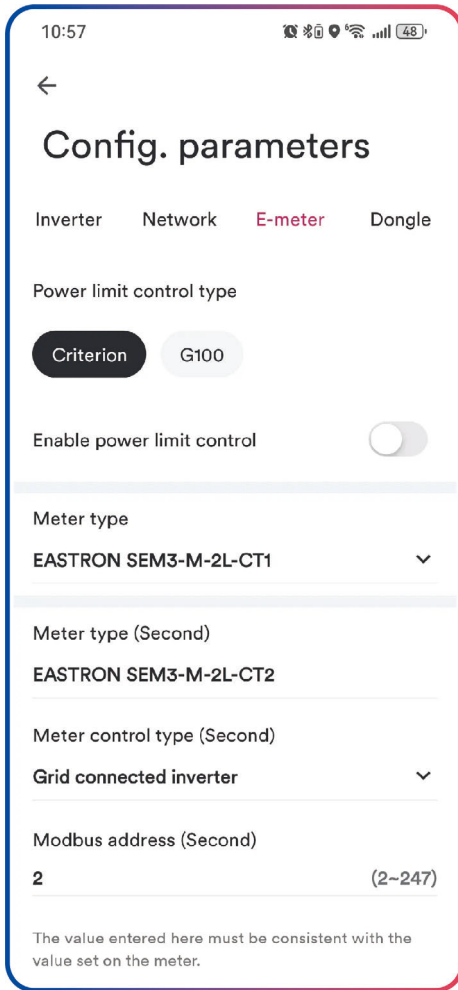

9 Decommissioning the product

9.1 Disconnecting the inverter from voltage sources

Prior to performing any work on the product, always disconnect it from all voltage sources as described in this section. Always adhere to the prescribed sequence.

WARNING

Danger to life due to electric shock from destruction of the measuring device due to overvoltage !

Overvoltage can damage a measuring device and result in voltage being present in the enclosure of the measuring device. Touching the live enclosure of the measuring device results in death or lethal injuries due to electric shock.

- Only use measuring devices with a DC input voltage range of 1100 V or higher.

Procedure:

Step 1: Disconnect the miniature circuit breaker and secure against reconnection.

Step 2: Disconnect the DC switch and secure against reconnection.

Step 3: Wait until the LEDs have gone out.

Step 4: Use a current clamp meter to ensure that no current is present in the DC cables.

DANGER

Danger to life due to electric shock when touching exposed DC conductors or DC plug contacts if the DC connectors are damaged or loose !

The DC connectors can break or become damaged, become free of the DC cables, or no longer be connected correctly if the DC connectors are released and disconnected incorrectly. This can result in the DC conductors or DC plug contacts being exposed. Touching live DC conductors or DC plug connectors will result in death or serious injury due to electric shock.

- Wear insulated gloves and use insulated tools when working on the DC connectors.
- Ensure that the DC connectors are in perfect condition and that none of the DC conductors or DC plug contacts are exposed.
- Carefully release and remove the DC connectors as described in the following.

Step 5: Loosen and remove the DC connector.

Type 1 DC connector

Release and remove the DC connectors. To do so, insert a flat-blade screwdriver or an angled screwdriver (blade width: 3.5mm) into one of the side slots and pull the DC connectors out.

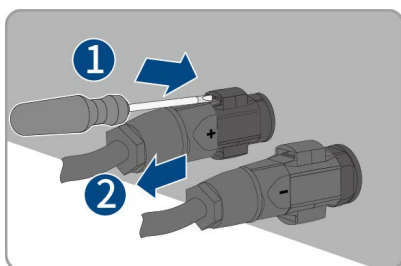

Type 2 DC connector

To remove DC plug connectors, insert a wrench tool into the slots and press the wrench tool with an appropriate force.

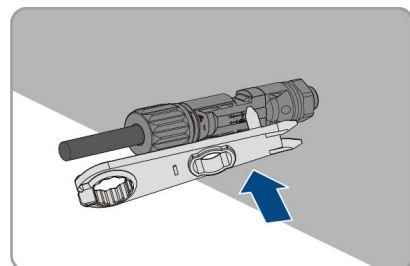

Step 6: Ensure that no voltage is present between the positive terminal and negative terminal at the DC inputs using a

suitable measuring device.

Step 7: Loosen and remove the Grid connector.

Unlock instructions

① Rotate the latch as shown.

② Remove the female end of the cable to unlock the account.

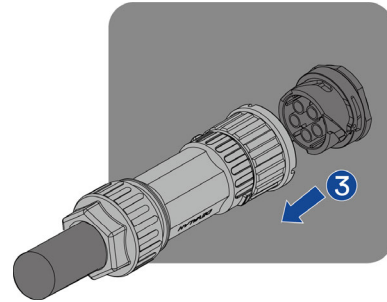
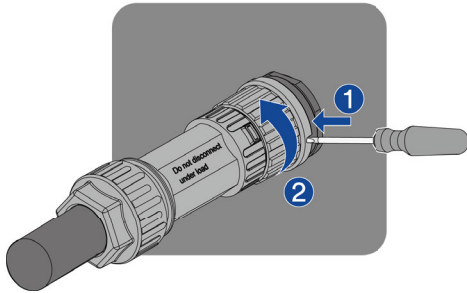

Step 8: Loosen and remove the EPS Load connector.

Unlock instructions

① Rotate the latch as shown.

② Remove the female end of the cable to unlock the account.

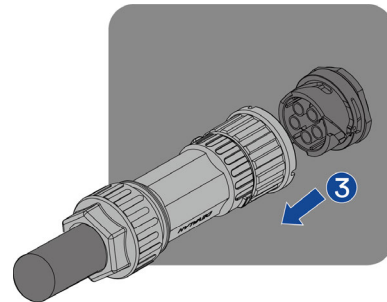
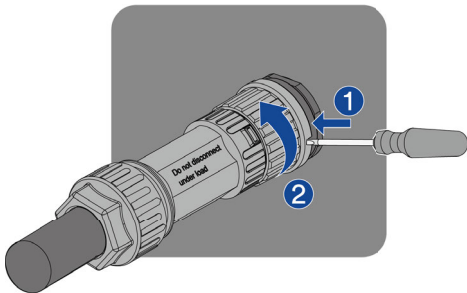

Step 9: Loosen and remove the GEN connector.

Unlock instructions

① Rotate the latch as shown.

② Remove the female end of the cable to unlock the account.

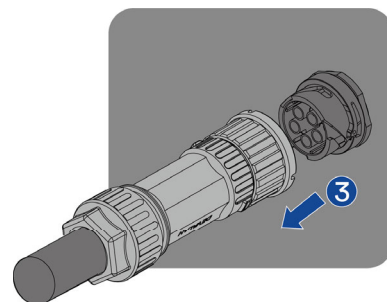
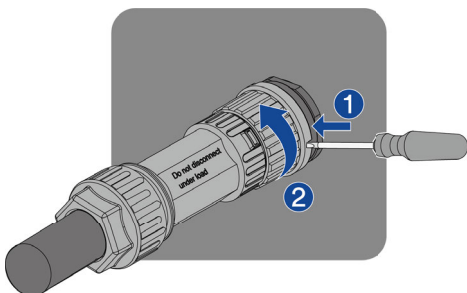

Step 10: Loosen and remove the Battery connector.

Unlock instructions

① Insert a flat-blade screwdriver or an angled screwdriver (blade width: 3.5mm) into one of the side slots.

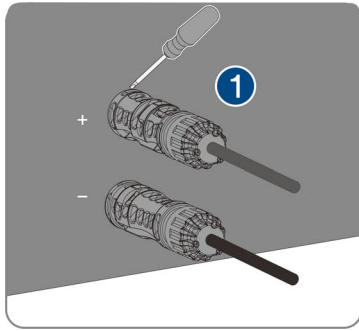

② Pull the DC connectors out.

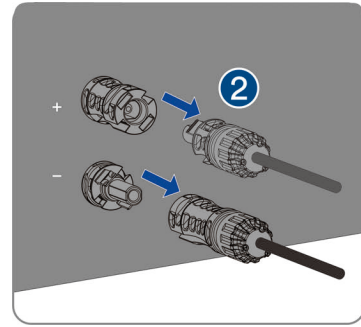

Step 11: Remove the communication cover. Remove the communication cable in reverse order by referring to 6.7 Communication equipment connection.

Step 12: Hold down the buckle on the side of the Ai-Dongle and pull out the Ai-Dongle terminal.

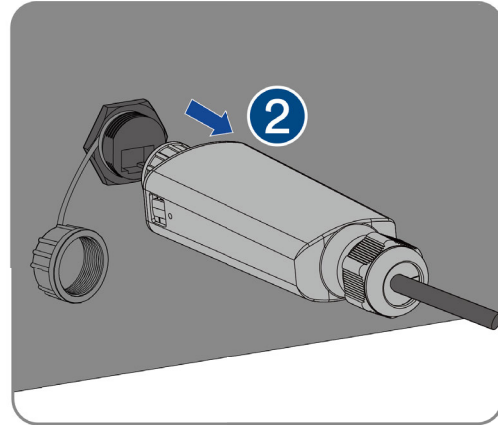
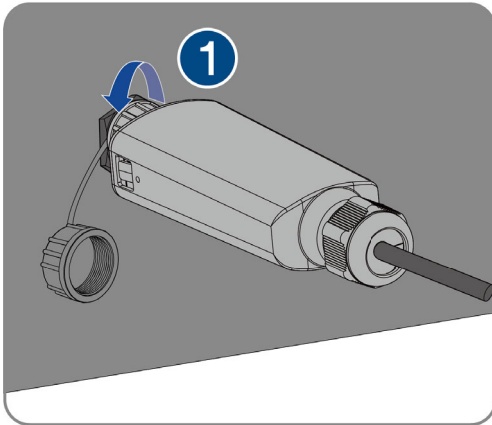

9.2 Dismantling the inverter

After disconnecting all electrical connections as described in Section 9.1, the inverter can be removed as follows

Procedure:

Step 1: Dismantle the inverter referring to “5.3 Mounting” in reverse steps.

Step 2: If necessary, remove the wall-mounting bracket from the wall.

Step 3: If the inverter will be reinstalled in the future, please refer to “3.2 Inverter Storage” for a proper conservation.

10 Technical data

10.1 ASW05 kH/06kH/08kH/10kH/12kH-T2-DG

Type	ASW05KH-T2-DG	ASW06KH-T2-DG	ASW08KH-T2-DG	ASW10KH-T2-DG	ASW12KH-T2-DG
DC Input					
Maximum power of PV array	7500 Wp	9000 Wp	12000 Wp	15000 Wp	18000 Wp
Max. power per MPP tracker	7500 W	9000 W	10000 W	10000 W	10000 W
Maximum input voltage	1100 V				
Rated input voltage	630 V				
Minimum input voltage	60 V				
Initial input voltage	180 V				
MPP voltage range	150-950 V	150-950 V	150-950V	150-950V	150-950V
MPP voltage range at Pnom	250~850 V	290~850 V	350-850 V	380-850 V	450-850 V
Max. input current	20 A/20 A				
Isc PV (absolute maximum)	30 A/30 A				
Maximum reverse current into the PV modules	0 A				
Number of independent MPP inputs	2				
Strings per MPP input	PV1:1/PV2:1				
Overvoltage category in accordance with ICE 60664-1	II				
AC Input and Output					
Rated output power at 230 V	5000 W	6000 W	8000 W	10000 W	12000 W
Rated apparent power at $\cos \varphi = 1$	5000 VA	6000 VA	8000 VA	10000 VA	12000 VA
Maximum apparent power at $\cos \varphi = 1$	5000 VA	6000 VA	8000 VA	10000 VA	12000 VA
Rated grid voltage	220 V / 380 V [3/N/PE] 230 V / 400 V [3/N/PE] 240 V / 415 V [3/N/PE]				
Grid voltage range	270-480 V (Phase to Phase)				
Rated grid frequency	50 Hz/60 Hz				
Grid frequency range	45-55 Hz/55-65 Hz				
Rated output current at 220 V	7.6 A	9.1 A	12.2 A	15.2 A	18.2 A
Rated output current at 230 V	7.3 A	8.7 A	11.6 A	14.5 A	17.4 A
Rated output current at 240 V	7.0 A	8.4 A	11.2 A	13.9 A	16.7 A
Maximum output current	8.0 A	9.6 A	12.8 A	16.0 A	19.2 A
Max. input power from grid	10000 W	12000 W	16000 W	20000 W	24000 W
Max. input current from grid	14.5 A	17.4 A	23.2 A	29.0 A	34.8 A
Inrush current	<20% of nominal AC current for a maximum of 10ms				
Contribution to peak short-circuit current ip	60 A				
Initial short-circuit alternating current (Ik" first single period effective value)	8.0 A	9.6 A	12.8 A	16.0 A	19.2 A
Short circuit current continuous [ms] (max output fault current)	8.0 A	9.6 A	12.8 A	16.0 A	19.2 A
Recommended rated current of AC circuit Breaker	20.0 A	25.0 A	32.0 A	32.0 A	40.0 A
Total harmonic distortion of the output current with total harmonic distortion of	<3% (of nominal power)				

the AC voltage <2%, and AC power >50% of the rated power					
Adjustable displacement power factor	0.8 leading to 0.8 lagging				
Overtoltage category in accordance with IEC 60664-1	III				
Efficiency					
Maximum efficiency	98.0%	98.2%	98.4%	98.4%	98.4%
European weighted efficiency	97.2%	97.5%	97.9%	97.9%	97.9%
Battery data					
Max. charging power from PV and grid	12000W	12000W	12000W	12000W	12000W
Max. charging power from grid	5000 W	6000 W	8000 W	10000 W	12000 W
Max discharging power	5000 W	6000 W	8000 W	10000 W	12000 W
Battery voltage range	120~600 V				
Max charging current	50 A				
Max discharging current	50 A				
Rated charging current	50 A				
Rated discharging current	50 A				
Battery type	LiFePO4				
EPS load data					
Rated apparent power at 400V	5000 W	6000 W	8000 W	10000 W	12000 W
Max. continuous apparent power at 400V	5000 VA	6000 VA	8000 VA	10000 VA	12000 VA
Max. power on each phase at 400V, continuous on-grid	3333 W	4000 W	5333 W	6667 W	8000 W
Max. apparent power at 400V <10s	10000 VA	12000 VA	16000 VA	20000 VA	24000 VA
Nominal output voltage	220 V / 380 V [3/N/PE] 230 V / 400 V [3/N/PE] 240 V / 415 V [3/N/PE]				
AC grid frequency	50 Hz / 60 Hz				
Max. continuous output current	8.0 A	9.6 A	12.8 A	16.0 A	19.2 A
Max. output current < 10s	14.5 A	17.4 A	23.2 A	29.0 A	34.8 A
Rated current at 400V	7.3 A	8.7 A	11.6 A	14.5 A	17.4 A
Max. current at 400V, continuous on-grid	14.6 A	17.4 A	23.2 A	29.0 A	34.8 A
Total harmonic distortion (THDv, linear load)	2%				
Switching time to battery-backup operation	<10 ms				
Generator side data					
Max. input apparent power (off-grid)	7500 VA	9000 VA	12000 VA	15000 VA	18000 VA
Max. continuous input current (off-grid)	a.c. 10.9 A	a.c. 13.0 A	a.c. 17.4 A	a.c. 21.8 A	a.c. 26.1 A
Power factor range (off-grid)	0.8 ind ... 0.8 cap				
Max. charging power of battery	5000 W	6000 W	8000 W	10000 W	12000 W
Rated AC voltage	220 V / 380 V [3/N/PE] 230 V / 400 V [3/N/PE] 240 V / 415 V [3/N/PE]				
Rated AC frequency	50 Hz / 60 Hz				

(1) The voltage range meets the requirements of the corresponding national grid code.

(2) The frequency range meets the requirements of the corresponding national grid code.

(3) Only the three-phase generator are supported.

10.2 ASW08kH/10kH/12kH/15kH-T3-DG

Type	ASW08KH -T3-DG	ASW10KH -T3-DG	ASW12KH -T3-DG	ASW15KH -T3-DG
DC Input				
Maximum power of PV array	12000 Wp	15000 Wp	18000 Wp	22500 Wp
Max. power per MPP tracker	10000 W	10000 W	10000 W	10000 W
Maximum input voltage	1100 V			
Rated input voltage	630 V			
Minimum input voltage	60 V			
Initial input voltage	180 V			
MPP voltage range	150-950 V	150-950 V	150-950 V	150-950 V
MPP voltage range at Pnom	250-850 V	320-850 V	380-850 V	440-850 V
Max. input current	16 A/16 A/16 A			
Isc PV (absolute maximum)	24 A/24 A/24 A			
Maximum reverse current into the PV modules	0 A			
Number of independent MPP inputs	3			
Strings per MPP input	PV1:1/PV2:1/PV3:1			
Overvoltage category in accordance with IEC 60664-1	II			
AC Input and Output				
Rated output power at 230 V	8000 W	10000 W	12000 W	15000 W
Rated apparent power at $\cos \varphi = 1$	8000 VA	10000 VA	12000 VA	15000 VA
Maximum apparent power at $\cos \varphi = 1$	8000 VA	10000 VA	12000 VA	15000 VA
Rated grid voltage	220 V / 380 V [3/N/PE] 230 V / 400 V [3/N/PE] 240 V / 415 V [3/N/PE]			
Grid voltage range	270-480 V (Phase to Phase)			
Rated grid frequency	50 Hz/60 Hz			
Grid frequency range	45-55 Hz/55-65 Hz			
Rated output current at 220 V	12.2 A	15.2 A	18.2 A	22.7A
Rated output current at 230 V	11.6 A	14.5 A	17.4 A	21.7A
Rated output current at 240 V	11.2 A	13.9 A	16.7 A	20.8A
Maximum output current	12.8 A	16.0 A	19.2 A	23.9A
Max. input power from grid	16000 W	20000 W	24000 W	24000W
Max. input current from grid	23.2 A	29.0 A	34.8 A	34.8A
Inrush current	<20% of nominal AC current for a maximum of 10ms			
Contribution to peak short-circuit current ip	60 A			
Initial short-circuit alternating current (Ik" first single period effective value)	12.8 A	16.0 A	19.2 A	23.9A
Short circuit current continuous [ms] (max output fault current)	12.8 A	16.0 A	19.2 A	23.9 A
Recommended rated current of AC circuit Breaker	32.0 A	32.0 A	40.0 A	40.0 A
Total harmonic distortion of the output current with total harmonic distortion of the AC voltage <2%, and AC power >50% of the rated power	<3% (of nominal power)			
Adjustable displacement power factor	0.8 leading to 0.8 lagging			
Overvoltage category in accordance with IEC 60664-1	III			

Efficiency				
Maximum efficiency	98.4%	98.4%	98.4%	98.4%
European weighted efficiency	97.9%	97.9%	97.9%	97.9%
Battery data				
Max. charging power from PV and grid	12000 W	12000 W	12000 W	15000 W
Max. charging power from grid	8000 W	10000 W	12000 W	15000 W
Max discharging power	8000 W	10000 W	12000 W	15000 W
Battery voltage range	120~600 V			
Max charging current	50 A			
Max discharging current	50 A			
Rated charging current	50 A			
Rated discharging current	50 A			
Battery type	LiFePO4			
EPS load data				
Rated apparent power at 400V	8000 W	10000 W	12000 W	15000 W
Max. continuous apparent power at 400V	8000 VA	10000 VA	12000 VA	16500 VA
Max. power on each phase at 400V, continuous on-grid	5333 W	6667 W	8000 W	8000 W
Max. apparent power at 230V <10s	16000 VA	20000 VA	24000 VA	24000 VA
Nominal AC voltage	230 V / 400 V [3/N/PE]			
AC grid frequency	50 Hz / 60 Hz			
Max. continuous output current	12.8 A	16.0 A	19.2 A	23.9A
Max. output current < 10s	23.2 A	29.0 A	34.8 A	34.8A
Rated current at 400V	11.6 A	14.5 A	17.4 A	21.7A
Max. current at 400V, continuous on-grid	23.2 A	29.0 A	34.8 A	34.8A
Total harmonic distortion (THDv, linear load)	2%			
Switching time to battery-backup operation	<10 ms			
Generator side data				
Max. input apparent power (off-grid)	12000 VA	15000 VA	18000 VA	18000 VA
Max. continuous input current (off-grid)	a.c. 17.4 A	a.c. 21.8 A	a.c. 26.1 A	a.c. 26.1 A
Power factor range (off-grid)	0.8 ind ... 0.8 cap			
Max. charging power of battery	8000 W	10000 W	12000 W	15000W
Rated AC voltage	220 V / 380 V [3/N/PE]			
	230 V / 400 V [3/N/PE]			
	240 V / 415 V [3/N/PE]			
Rated AC frequency	50 Hz / 60 Hz			

- (1) The voltage range meets the requirements of the corresponding national grid code.
- (2) The frequency range meets the requirements of the corresponding national grid code.
- (3) Only the three-phase generator are supported.

10.3 General data

Type	ASW05kH/06kH/08kH/10kH/12kH-T2-DG	ASW08kH/10kH/12kH	ASW15kH-T3-DG
Width × height × depth	625 mm × 465 mm × 240.5 mm		625 mm × 465 mm × 245 mm

Weight	27.8 kg	29.2 kg	30 kg
Topology	Non-isolated		
Operating temperature range	-25°C ... +60°C		
Allowable relative humidity range (non-condensing)	0% ... 100%		
Degree of protection for electronics in accordance with IEC 60529	IP66		
Climatic category in accordance with IEC 60721-3-4	4K4H		
Protection class (according to IEC 62103)	I		
Pollution degree outside the enclosure	3		
Pollution degree inside the enclosure	2		
Max. operating altitude above mean sea level	4000 m (>3000 m derating)		
Self-consumption (night)	<10W		
Cooling method	Natural convection	Smart cooling	
Typical noise emission	< 35 dB(A)@1m	< 45 dB(A)@1m	
Display	LED indicator, App		
Demand response mode in accordance with AS/NZS 4777.2	DRM0		
Export active power output	Via connecting Smart meter		
Earth Fault Alarm	Cloud based, Visible		
Interfaces	RS485, WiFi stick, Ethernet		
Communication	ModBus RTU, Modbus TCP and CAN		
Mounting information	Wall mounting bracket		
Radio technology	WLAN 802.11 b/g/n		
Radio spectrum	2.4 GHz		
Maximum transmission power	100 mW		

10.4 Protective device

Protective devices	ASW05kH/06kH/08kH/10kH/12kH-T2-DG ASW08kH/10kH/12 kH /15kH -T3-DG
DC reverse polarity protection	Integrated
DC isolator	Integrated
Ground fault monitoring	Integrated
AC short-circuit current capability	Integrated
Active anti-islanding protection	Integrated
PV string current monitoring	Integrated
DC current injection monitoring	Integrated
Low voltage ride through	Integrated
High voltage ride through	Integrated
Overvoltage protection	DC Type II / AC Type III

11 Troubleshooting

When the PV system does not operate normally, we recommend the following solutions for quick troubleshooting. If an error or warning occurs, there will have "Event Messages" display in the LCD screen and monitor tools. The corresponding corrective measures are as follows:

Error code	Message	Corrective measures
3-5 8,9	Permanent Fault	<ul style="list-style-type: none"> • Disconnect the inverter from the battery, the grid and the PV array and reconnect after 3 minutes. • If this fault is still being shown, contact the service. • The inverter temperature should above -40°C.
10	Device fault	<ul style="list-style-type: none"> • Disconnect the inverter from the battery, the grid and the PV array and reconnect after 3 minutes. • If this fault is still being shown, contact the service. • The inverter temperature should above -40°C.
12	HW output over current	<ul style="list-style-type: none"> • Disconnect the inverter from the AC grid, PV module, battery and reconnect after 5 minutes, check is it solved. • If not, disconnect the load, and restart the inverter to check is it solved. • If the fault disappear, then connect the load one by one to check which load result this fault. • Make exchange of the inverter if complete the above guide with fault is still there.
33	Grid frequency fault	<ul style="list-style-type: none"> • Check the grid and EPS frequency and observe how often major fluctuations occur. Contact customer service if EPS frequency abnormal. • If this fault is caused by frequent fluctuations, try to modify the operating parameters after informing the grid operator first.
34	Grid voltage fault	<ul style="list-style-type: none"> • Check the grid voltage and grid connection on inverter. • Check the grid voltage at the point of connection of inverter. <p>If the grid voltage is outside the permissible range due to local grid conditions, try to modify the values of the monitored operational limits after informing the electric utility company first.</p> <p>If the grid voltage lies within the permitted range and this fault still occurs, please call service.</p>
36	GFCI fault	<ul style="list-style-type: none"> • Make sure the grounding connection of the inverter is reliable. • Make a visual inspection of all PV cables and modules. <p>If this fault is still shown, contact the service.</p>
37	PV over voltage fault	<ul style="list-style-type: none"> • Check the open-circuit voltages of the strings and make sure it is below the maximum DC input voltage of the inverter. <p>If the input voltage lies within the permitted range and the fault still occurs, please call service.</p>
38	Isolation fault	<ul style="list-style-type: none"> • Check the PV array's insulation to ground and make sure that the insulation resistance to ground is greater than 1 Mohm. Otherwise, make a visual inspection of all PV cables and modules. • Make sure the grounding connection of the inverter is reliable. <p>If this fault occurs often, contact the service.</p>
40	Over temperature fault	<ul style="list-style-type: none"> • Check whether the airflow to the heat sink is obstructed. • Check whether the ambient temperature around the inverter is too high.
48	10 minutes average over voltage fault	<ul style="list-style-type: none"> • Check the grid voltage at the point of connection of inverter. <p>If the grid voltage is outside the permissible range due to local grid conditions, try to modify the values of the monitored operational limits after informing the electric utility company first.</p> <p>If the grid voltage lies within the permitted range and this fault still occurs, please call service.</p>
69	NS-protection fault	<ul style="list-style-type: none"> • Please disable External input signal function in APP if inverter does not connect NS-

		<ul style="list-style-type: none"> protection device. Please check the cable of NS-protection device, if the cable connection is normal, the NS-protection triggered.
70	AFCI Self Test Fail	<ul style="list-style-type: none"> Make exchange of the inverter.
71	AFCI Fault	<ul style="list-style-type: none"> Disconnect each MPPT tracker, and eliminate any abnormalities. Make exchange of the inverter if complete the above guide with fault is still there.
72	Parallel RS 485 Comm Fault	<ul style="list-style-type: none"> Check comm line and 120ohm Resistors.
73	Parallel CAN Comm Fault	<ul style="list-style-type: none"> Check comm line and 120ohm Resistors.
76	Generator Voltage or Fac Out of Range	<ul style="list-style-type: none"> Check whether the diesel generator works properly Check that the Gen-port is correctly connected Check whether the diesel generator is connected but set the port mode to smart load mode
77	Generator Phase sequence error	<ul style="list-style-type: none"> Check that the phase sequence of the connector connection is consistent with that of the power grid
78	Generator or smart load Overloaded	<ul style="list-style-type: none"> In generator mode: <ul style="list-style-type: none"> a) Check the maximum power setting of the generator machine. b) Check whether the load power exceeds the maximum limit. In smart load mode: <ul style="list-style-type: none"> a) Check whether the smart load power exceeds the maximum limit.
79	Parallel Multiple Host Fault	<ul style="list-style-type: none"> Check host quantity and set one host.
156	Internal fan fault	<ul style="list-style-type: none"> This fault only occurs in the ASW15KH-T3-DG model. If this fault is still shown, contact the service.
157	External fan fault	<ul style="list-style-type: none"> This fault only occurs in the ASW15KH-T3-DG model. Check whether the fan blades of the external fan are blocked. If this fault is still shown, contact the service.
W192	Meter or CT loss	<ul style="list-style-type: none"> If CT is enable, check the phase sequence, connector and Buckle of CT, The phase sequence of CT needs to be consistent with the grid and inverter. If meter is enable, check the meter screen, if there is no phone symbol on meter screen check the communication connection of meter; if there is phone symbol on meter screen, please re-plug the connector of meter. If this fault occurs often, contact the service.

Contact the service if you meet other problems not in the table.

12 Maintenance

12.1 Cleaning the contacts of the DC switch

DANGER

High voltage of PV string may cause life danger!

If the DC connector is disconnected while the PV inverter is working, electric arc may occur, causing electric shock and burns.

- Please disconnect the circuit breaker on the AC side first, and then disconnect the DC switch.

To ensure the normal operation of the DC input switch, it is necessary to clean the DC switch contacts every year.

Procedure:

Step 1: Disconnect the AC disconnect and prevent accidental restart.

Step 2: Rotate the DC switch handle from the “ON” position to the “OFF” position for 5 times.

12.2 Cleaning air inlet and outlet

CAUTION

Hot enclosure or heat sink may cause personal injury!

When the inverter is working, the temperature of the enclosure or heat sink will be higher than 70°C, and the contact may cause burns.

- Before cleaning the air outlet, shut down the machine and wait for about 30 minutes until the temperature of the enclosure decreases to normal temperature.

A huge amount of heat is generated in the process of running the inverter. The inverter adopts a controlled forced-air cooling method. In order to maintain good ventilation, please check to make sure the air inlet and outlet are not blocked.

Procedure:

Step 1: Disconnect the AC side circuit breaker and ensure that it cannot be accidentally reconnected.

Step 2: Disconnect the DC switch, rotate the DC switch handle from the “ON” position to the “OFF” position.

Step 3: Clean the air inlet and outlet of the inverter with a soft brush.

12.3 Fan maintenance

WARNING

Hot enclosure or heat sink may cause personal injury!

When the inverter is working, the temperature of the enclosure or heat sink may be higher than 70°C. Physical contact may cause burns.

- Before cleaning the air outlet, shut down the machine and wait approximately 30 minutes until the temperature of the enclosure decreases to a normal temperature.

Fans inside the inverter are used to cool the inverter during operation. If the fans do not operate normally, the inverter may not be cooled down and inverter efficiency may decrease. Therefore, it is necessary to clean the dirty fans and replace the broken fans in time.

Procedure:

Step 1: Turn OFF the AC circuit breaker downstream of the AC output of the inverter and ensure that it cannot be inadvertently turned ON.

Step 2: Disconnect the DC switch and rotate the DC switch handle from the “ON” position to the “OFF” position, turn OFF the battery switch. Wait for approximately 30 minutes until the heatsink temperature is reduced to normal temperature.

Step 3: Loosen the screw on the sealing plate of the fan module.

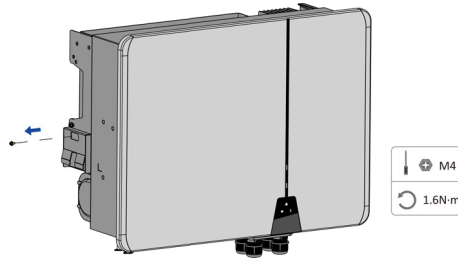

Step 4: Loosen the screw on the sealing plate of the fan module.

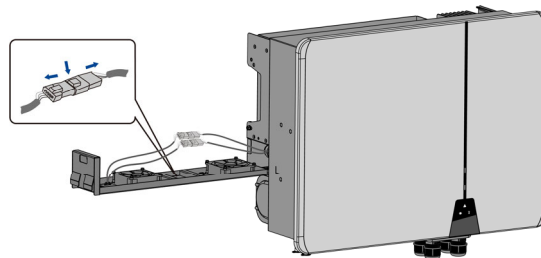

Step 5: Remove the screws at the bottom of the fan. Use a clean cloth, brush, or vacuum cleaner to clean the fan, or replace the faulty fan directly.

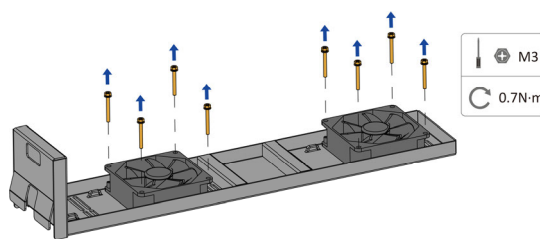
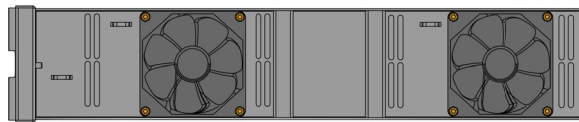

Step 6: Reinstall the fan back to the inverter in reverse order and restart the inverter.

13 Recycling and disposal

Dispose of the packaging and replaced parts according to the rules applicable in the country where the device is installed.





Do not dispose of the product together with the household waste but in accordance with the disposal regulations for electronic waste applicable at the installation site.

14 EU declaration of conformity

Within the scope of the EU directives



- Radio Equipment Directive 2014/53/EU (L 153/62-106. May 22. 2014) (RED)
- Restriction of the use of certain hazardous substances 2011/65/EU (L 174/88, June 8, 2011) and 2015/863/EU (L 137/10, March 31, 2015) (RoHS)

Solplanet Technology Co., Ltd. confirms herewith that the inverters described in this manual are in compliance with the fundamental requirements and other relevant provisions of the above mentioned directives.

The entire EU Declaration of Conformity can be found at www.solplanet.net.

15 Service and warranty

If you have any technical problems concerning our products, please contact Solplanet service. We require the following information in order to provide you with the necessary assistance:

- Inverter device type
- Inverter serial number
- Type and number of connected PV modules
- Error code
- Mounting location
- Installation date
- Warranty card

Warranty terms and conditions can be downloaded at www.solplanet.net.

When the customer needs warranty service during the warranty period, the customer must provide a copy of the invoice, factory warranty card, and ensure the electrical label of the inverter is legible. If these conditions are not met, Solplanet has the right to refuse to provide with the relevant warranty service.

16 Contact

EMEA

Service email: service.EMEA@solplanet.net

APAC

Service email: service.APAC@solplanet.net

LATAM

Service email: service.LATAM@solplanet.net

Solplanet Technology Co., Ltd

Hotline: +86 400 801 9996

Add.: Room 904 - 905, No. 757 Mengzi Road, Huangpu District, Shanghai 200023

<https://solplanet.net/contact-us/>

Scan QR code:



Android

Scan QR code:



iOS

