

Monoblock Air Source Heat Pump

Serie SOL AIRPOWER

Manual

SOL-006HC1 / SOL-010HC3 / SOL-014HC3
SOL-018HC3 / SOL-024HC3

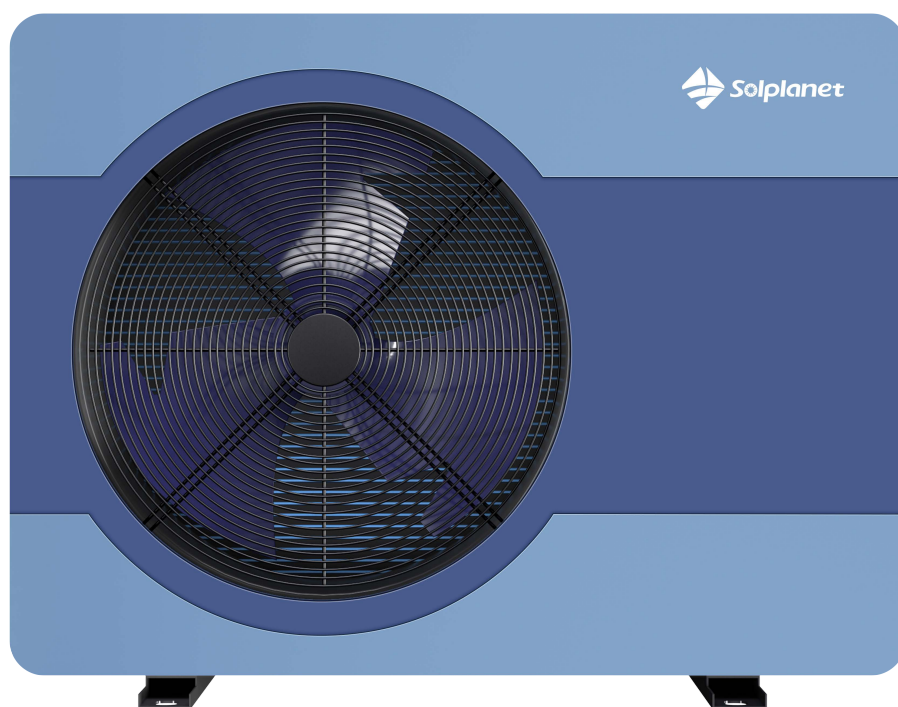



Table on contents

CHAPTER 1: PRODUCT INTRODUCTION	4
1.1. PRODUCT MODEL PICTURE COMPARISON TABLE.....	4
1.2. PRODUCT MODEL PARAMETER TABLE.....	5
1.3. EXPLODED VIEW OF THE MODEL.....	10
1.4. SYSTEM DIAGRAM AND PERFORMANCE CURVE	12
1.4.1 SCHEMATIC DIAGRAM OF TRIGENERATION REFRIGERATION SYSTEM	12
1.4.2 WORKING PRINCIPLE OF HEAT PUMP	13
1.4.3 INTRODUCTION TO HEAT PUMP SYSTEM COMPONENTS.....	14
1.4.4 PERFORMANCE CURVE	20
CHAPTER 2: PRODUCT SELECTION AND INSTALLATION.....	25
2.1 PRODUCT INSTALLATION INSTRUCTIONS AND SPECIAL PRECAUTIONS	25
2.1.1 DISCLAIMER.....	25
2.1.2 <i>Warning</i>	26
2.1.3 <i>Precautions</i>	26
2.2 UNIT INSTALLATION.....	27
2.2.1 HEAT PUMP UNIT INSTALLATION.....	27
2.2.2 INSTALLATION OF AUXILIARY WATER PUMPS.....	28
2.3 INSTALLATION OF PIPES; WATER PRESSURE COMMISSIONING; PIPE INSULATION REQUIREMENTS	29
2.3.1 DISTRIBUTION LINE INSTALLATION SYSTEM DIAGRAM	29
2.3.1.1 <i>Schematic diagram of waterway system installation</i>	29
2.3.1.2 <i>Water quality requirements for unit use</i>	30
2.3.1.3 <i>Waterway system installation steps</i>	30
2.3.1.4 <i>Water line replenishment and pipe emptying steps</i>	30
2.3.2 <i>The hydraulic test of hydraulic pressure debugging shall comply with the following regulations</i> ...	30
2.3.1.6 <i>Pipe insulation requirements</i>	31
2.4 ELECTRICAL WIRING CONSIDERATIONS	31
2.5 ROOM HEAT LOAD CALCULATION	33
2.5.1 BASIC REQUIREMENTS	33
2.5.2 WATER SYSTEM DESIGN	34
2.5.3 WATER DIVIDER AND WATER COLLECTOR CONFIGURATION PRINCIPLE	35
2.5.4 SELECTION OF FLOOR HEATING HEAT PUMP UNITS.....	35
2.6 WATERWAY FREEZE PROTECTION	44
CHAPTER III: ELECTRICAL OPERATIONS.....	45
3.1 CONTROL:	45
3.1.1 <i>Stop running</i>	45
3.1.2 <i>DC Pump Control (PWM)</i>	45
3.1.3 <i>Boot Control</i>	46
3.1.3.2 COMPRESSOR SHUTDOWN CONDITIONS.....	47
3.1.3.3 COMPRESSOR OPERATING FREQUENCY CONTROL.....	47
3.1.3.4 COMPRESSOR TEMPERATURE SHUTDOWN CONTROL MODE.....	48
3.1.4 HIGH TEMPERATURE STERILIZATION.....	48
3.1.5 SILENT MODE	49
3.1.6 WATERWAY EMPTYING MODE/FORCED OPENING OF THE PUMP	49
3.1.7 MANDATORY DEFROSTING	49
3.1.8 LINKAGE CONTROL.....	49
3.1.9 REFRIGERANT RECOVERY FUNCTION	50
3.1.10 EXPIRATION PASSWORD SETTINGS.....	50
3.1.11 CONTROL EH1/GAS CONTROL SIGNAL OUTPUT FOR ELECTRIC HEATING OF HOT WATER	50
3.1.12 HEATING AUXILIARY ELECTRIC HEATING EH2	52

3.1.13	UNIT AUXILIARY PUMP P_C.....	53
3.1.14	HOT WATER THREE-WAY VALVE SV1	53
3.1.15	AIR CONDITIONING THREE-WAY VALVE SV2.....	53
3.1.16	AIR CONDITIONING SECONDARY WATER PUMP P_B (SECONDARY SYSTEM)	53
3.1.17	HEAT SOURCE HOT WATER PUMP P_E.....	54
3.1.18	HEAT SOURCE HEATING WATER PUMP P_F.....	54
3.1.19	HOST WATER FLOW SWITCH PROTECTION.....	56
3.1.20	PROTECTION OF EXCESSIVE TEMPERATURE DIFFERENCE BETWEEN INLET AND OUTLET PIPES	57
3.1.21	HIGH VOLTAGE PROTECTION.....	58
3.1.22	LOW VOLTAGE TOO LOW PROTECTION	58
3.1.23	PROTECTION FROM EXCESSIVE EXHAUST TEMPERATURE	58
3.2	DISPLAY AND OPERATION OF THE REMOTE CONTROLLER:.....	59
3.2.1	REMOTE CONTROL INTERFACE DISPLAY AND OPERATION	59
3.2.3	SETTING AND OPERATION OF UNIT TOOLING NUMBERS.....	65
3.2.4	WIRING METHOD AND DISPLAY OF MULTIPLE UNIT NETWORKING	66
3.2.5	OPERATION METHOD OF UNIT STATUS PARAMETER QUERY	67
3.2.6	FACTORY PARAMETER SETTING METHOD	70
3.2.7	<i>Factory reset</i>	73
3.3	PUMP FLOW RANGE SETTING METHOD	81
3.4	LAYOUT OF OUTDOOR UNIT ELECTRIC CONTROL BOX	83
3.5	ELECTRICAL PCB DIAGRAMS.....	86
3.5.1	<i>Main Control Board Port Definition Diagram (AP1)</i>	86
3.5.2	<i>Pump expansion board port definition diagram (AP3)</i>	87
3.5.3	<i>Switching power supply port definition diagram (AP4)</i>	89
3.5.4	<i>DC fan board port definition diagram (AP5)</i>	89
3.5.5	<i>Compressor drive board port definition diagram (AP4)</i>	90
3.6	FAULT CODE AND CAUSE OF FAILURE	92
3.7	WATERWAY INSTALLATION AND WIRING	98
3.7.1	<i>The system legend illustrates the comparison</i>	98
3.7.2	INSTALLATION DIAGRAM OF A SINGLE FLOOR HEATING MODE WATERWAY SYSTEM.....	99
3.7.3	<i>Schematic diagram of wiring in floor heating, heating and cooling modes</i>	100
3.7.5	<i>Installation diagram of hot water + floor heating mode waterway system</i>	101
3.7.6	SCHEMATIC DIAGRAM OF HOT WATER + REFRIGERATION, HOT WATER + HEATING, HOT WATER +	102
3.7.8	<i>Wiring diagram in mixed mode</i>	104
3.7.10	<i>Schematic diagram of cascade mode waterway wiring</i>	106
3.7.12	<i>Schematic diagram of floor heating + cooling + hot water + gas waterway connection</i>	108
3.8	WIRING DIAGRAM OF EACH MODEL	111
CHAPTER 4: FAULT DIAGNOSIS AND TREATMENT.....		115
4.1	REPAIR USE TOOLS	115
4.2	MODEL DISASSEMBLY AND PARTS.....	117
4.3	COMMON TROUBLESHOOTING AND REPAIR	134
SCHEDULE		151
SCHEDULE A: HEAT DISSIPATION PER UNIT OF GROUND AND HEAT LOSS FROM THEGROUND IN THE LOWER LAYER OR SOIL		151
1.	THE HEAT DISSIPATION PER UNIT GROUND AREA OF PE-X PIPE AND THE HEAT LOSS OF DOWNWARD CONVERSION	151
2.	THE HEAT DISSIPATION AND DOWNWARD HEAT LOSS PER UNIT GROUND AREA OF PB PIPE.....	154
SCHEDULE B: COEFFICIENT OF EXPANSION OF WATER		157

Chapter 1: Product Introduction

1. 1. Product model picture comparison table

Model	SOL-006HC1, SOL-010HC1/3, SOL-014HC1/3
	
Model	SOL-018HC1/3, SOL-024HC3
	

1. 2. Product model Parameter Table

Model			SOL-006HC1	SOL-010HC1	SOL-010HC3	SOL-014HC1	SOL-014HC3	SOL-018HC1	SOL-018HC3	SOL-024HC3
Power Supply			220-240V ~/50Hz	220-240V ~/50Hz	380- 415V/3N~/50 Hz	220-240V ~/50Hz	380- 415V/3N~/50 Hz	220-240V ~/50Hz	380- 415V/3N~/50 Hz	380- 415V/3N~/50 Hz
Heating ¹	Capacity	KW	2.50-8.30	4.20-12.20	4.20-12.20	5.30-16.50	5.30-16.60	6.20-20.50	6.20-20.50	6.50-26.10
	Input Power	kW	0.57-1.92	0.86-2.88	0.86-2.88	1.15-4.15	1.15-4.15	1.36-5.28	1.36-5.28	1.78-6.45
	Input Current	A	2.53-8.52	3.82-12.77	1.46-4.89	5.10-18.41	1.86-6.70	6.10-23.67	2.31-8.96	2.87-10.35
Heating ²	Capacity	kW	2.30-7.62	3.85-11.20	3.85-11.20	4.90-15.10	4.90-15.10	6.30-19.90	6.30-19.90	6.90-26.10
	Input Power	kW	0.75-2.61	1.13-3.75	1.13-3.75	1.65-5.25	1.65-5.25	1.65-6.82	1.65-6.82	1.95-8.55
	Input Current	A	3.32-11.58	5.01-16.6	1.92-6.37	7.32-23.30	1.67-8.47	7.40-30.56	2.80-11.58	3.15-13.80
Cooling	Capacity	kW	1.80-7.10	2.60-10.30	2.60-10.30	4.50-13.50	4.50-13.50	5.50-17.50	5.50-17.50	5.20-21.30
	Input Power	kW	0.61-2.43	0.91-3.65	0.91-3.65	1.45-4.85	1.45-4.85	1.65-6.25	1.65-6.25	1.95-8.20
	Input Current	A	2.71-10.78	4.03-16.19	1.55-6.20	6.43-21.52	2.34-7.82	7.40-28.02	2.80-10.61	3.15-13.23
SCOP (Water Temp. At 35°C)			5.14	4.55	4.55	4.58	4.62	4.61	4.64	4.58
SCOP (Water Temp. At 55°C)			3.37	3.41	3.41	3.39	3.44	3.41	3.42	3.42
Rated Input Power		kW	2.71	3.83	3.83	6.2	6.2	7.5	7.5	10
Rated Input Current		A	12	17	6.5	27.5	10.50	35	13	17
Refrigerant Type/Charge/GWP		... /kg	R32/1.25/675	R32/1.8/675	R32/1.8/675	R32/2.8/675	R32/2.8/675	R32/3.5/675	R32/3.5/675	R32/3.5/675
CO ₂ Equivalent		/	0.84t	1.21t	1.21t	1.89t	1.89t	2.36t	2.36t	2.36t
Operation Pressure (Low Side)		MPa	1.5	1.5	1.5	1.5	1.5	1.5	1.5	1.5
Operation Pressure (High Side)		MPa	4.4	4.4	4.4	4.4	4.4	4.4	4.4	4.4

Rated Test Conditions:

Heating¹: Ambient Temp 7°C/6°C(DB/WB),Water-In/Out Temp 30°C/35°C Heating²: Ambient Temp 7°C/6°C(DB/WB),Water-In/Out Temp 47°C/55°C Cooling: Ambient Temp 35°C/24°C(DB/WB),Water-In/Out Temp 12°C/7°C

Model		SOL-006HC1	SOL-010HC1	SOL-010HC3	SOL-014HC1	SOL-014HC3	SOL-018HC1	SOL-018HC3	SOL-024HC3
Maximum Allowable Pressure	MPa	4.4	4.4	4.4	4.4	4.4	4.4	4.4	4.4
Electrical Shockproof	/	I	I	I	I	I	I	I	I
IP Class	/	IPX4	IPX4	IPX4	IPX4	IPX4	IPX4	IPX4	IPX4
Max. Outlet Water Temp.	°C	60	60	60	60	60	60	60	60
Operating Ambient Temperature	°C	-25~45	-25~45	-25~45	-25~45	-25~45	-25~45	-25~45	-25~45
Water Piping Connections	inch	G1	G1	G1	G1-1/4	G1-1/4	G1-1/2	G1-1/2	G1-1/2
Rated Water Flow	m ³ /h	1.1	1.75	1.75	2.52	2.52	3.2	3.2	4.12
Water Pressure Drop	kPa	25	27	27	30	30	32	32	35
Min/Max water pressure	MPa	0.1/0.3	0.1/0.3	0.1/0.3	0.1/0.3	0.1/0.3	0.1/0.3	0.1/0.3	0.1/0.3
Noise Level	dB(A)	50	51	51	55	55	56	56	58
Net Dimensions (LxWxH)	mm	1100×445×850			1110×480×850		1110×445×1450		
Pack Dimensions (LxWxH)	mm	1160×530×1010			1160×565×1010		1170×530×1610		
Net Weight	kg	102	107	107	124	124	151	151	160
Gross Weight	kg	114	119	119	136	136	168	168	177

1-3

Note: Parameters are subject to change without prior notice. Please refer to the unit nameplate.

1.2 Structural dimensional drawing

Models: SOL-006HC1, SOL-010HC1/3

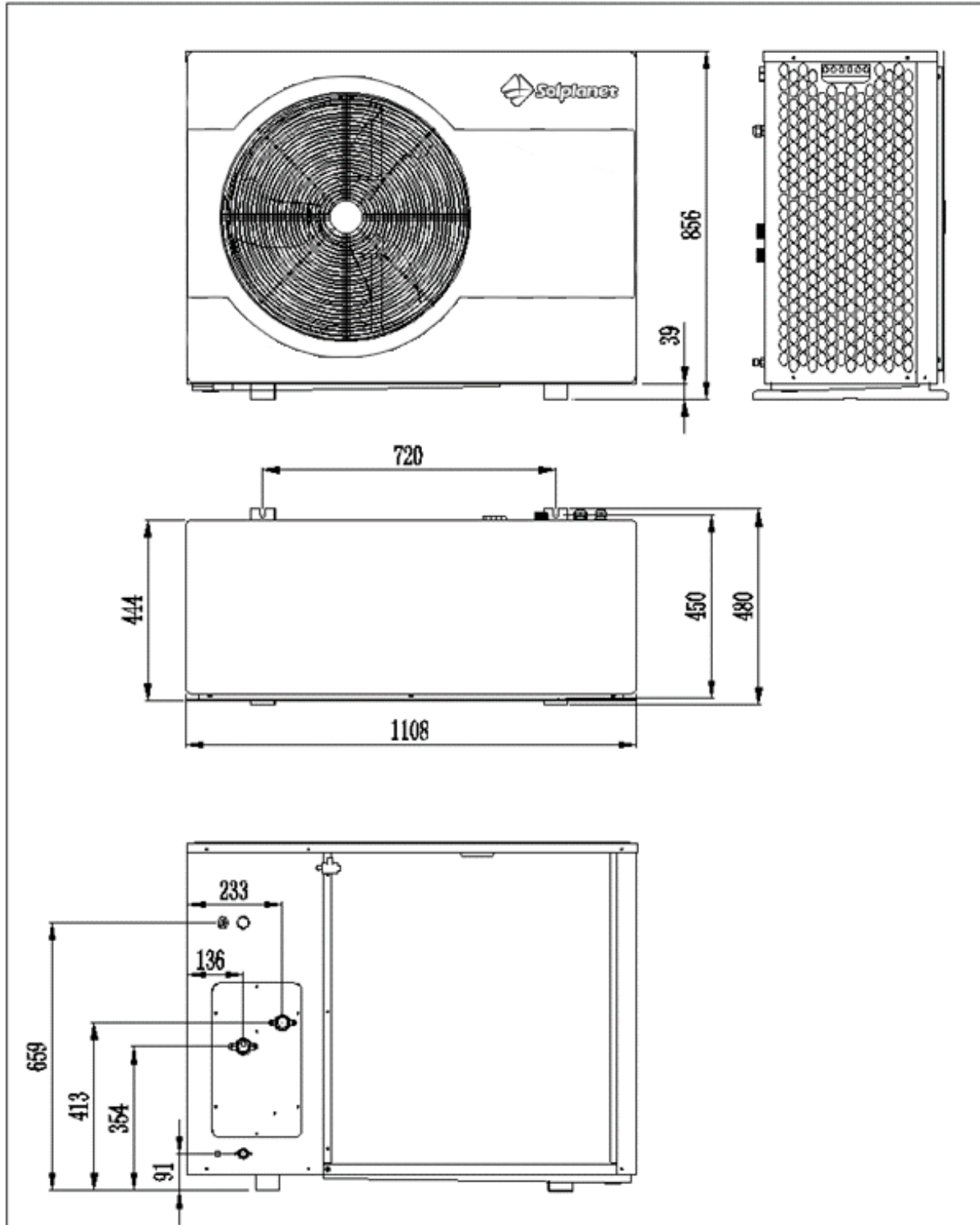

Models: SOL-014HC1/3

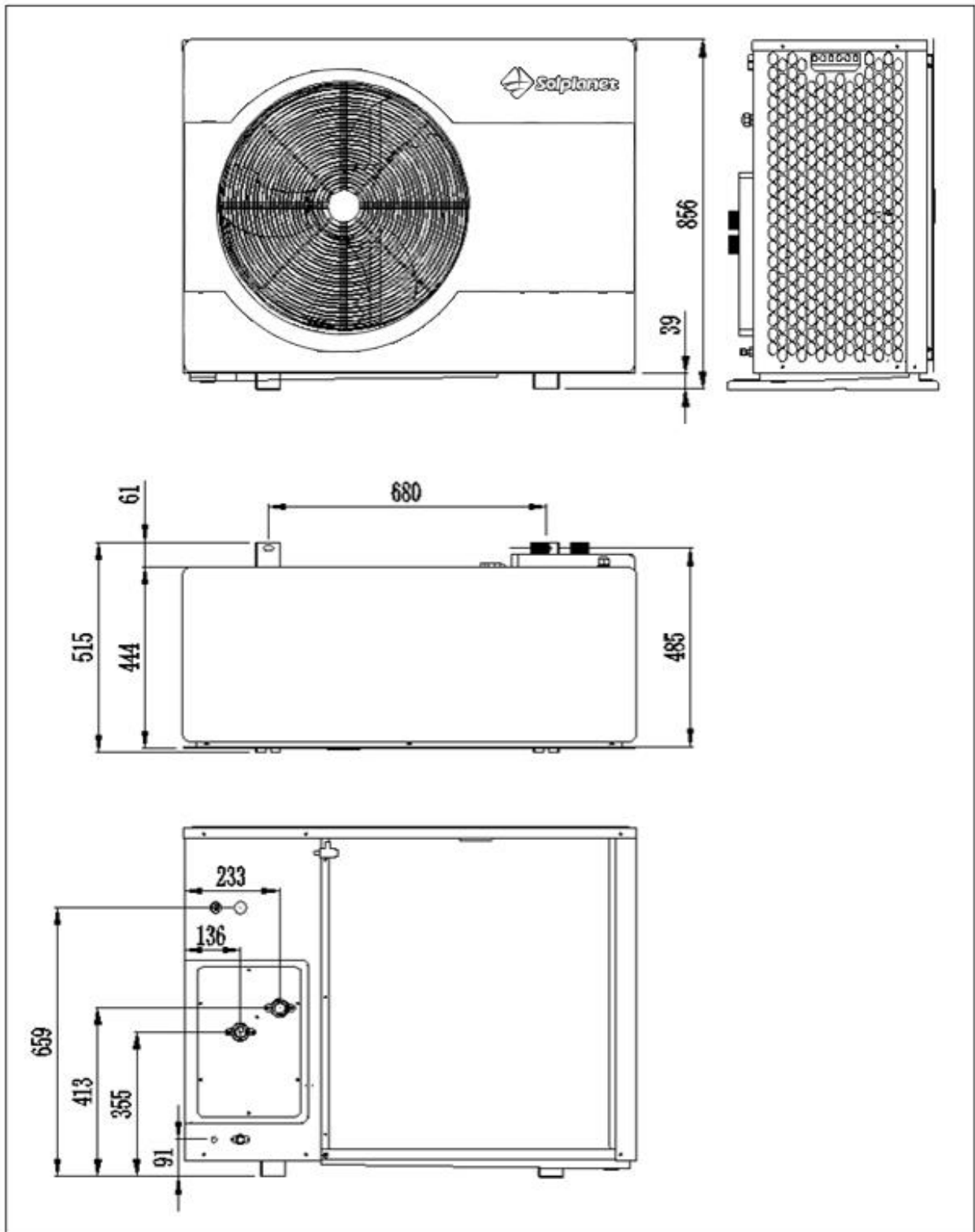

Models: SOL-018HC1, SOL-018HC3, SOL-024HC3

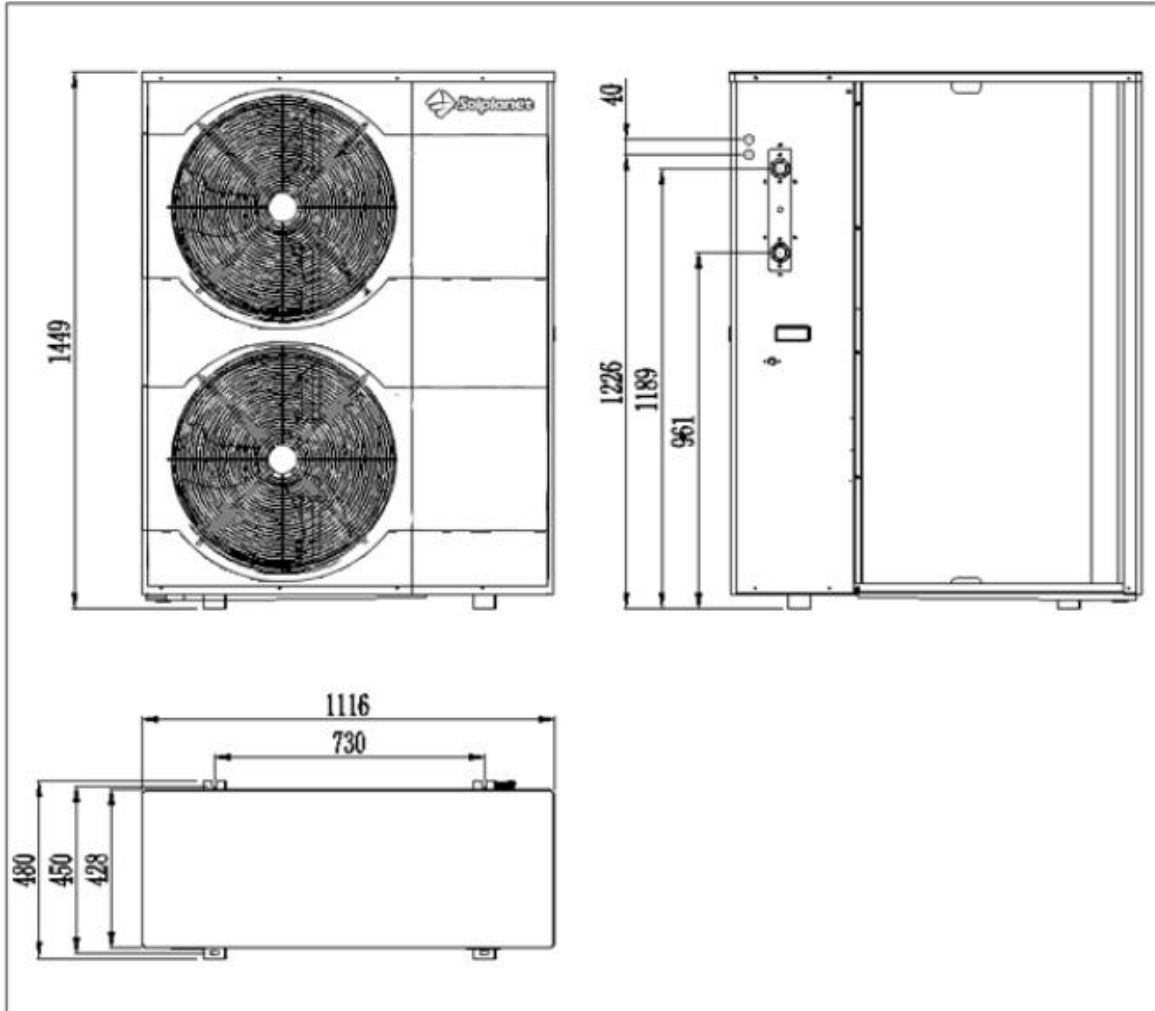

1.3 Exploded view of the model

Models: SOL-006HC1, SOL-010HC1/3, SOL-014HC1/3

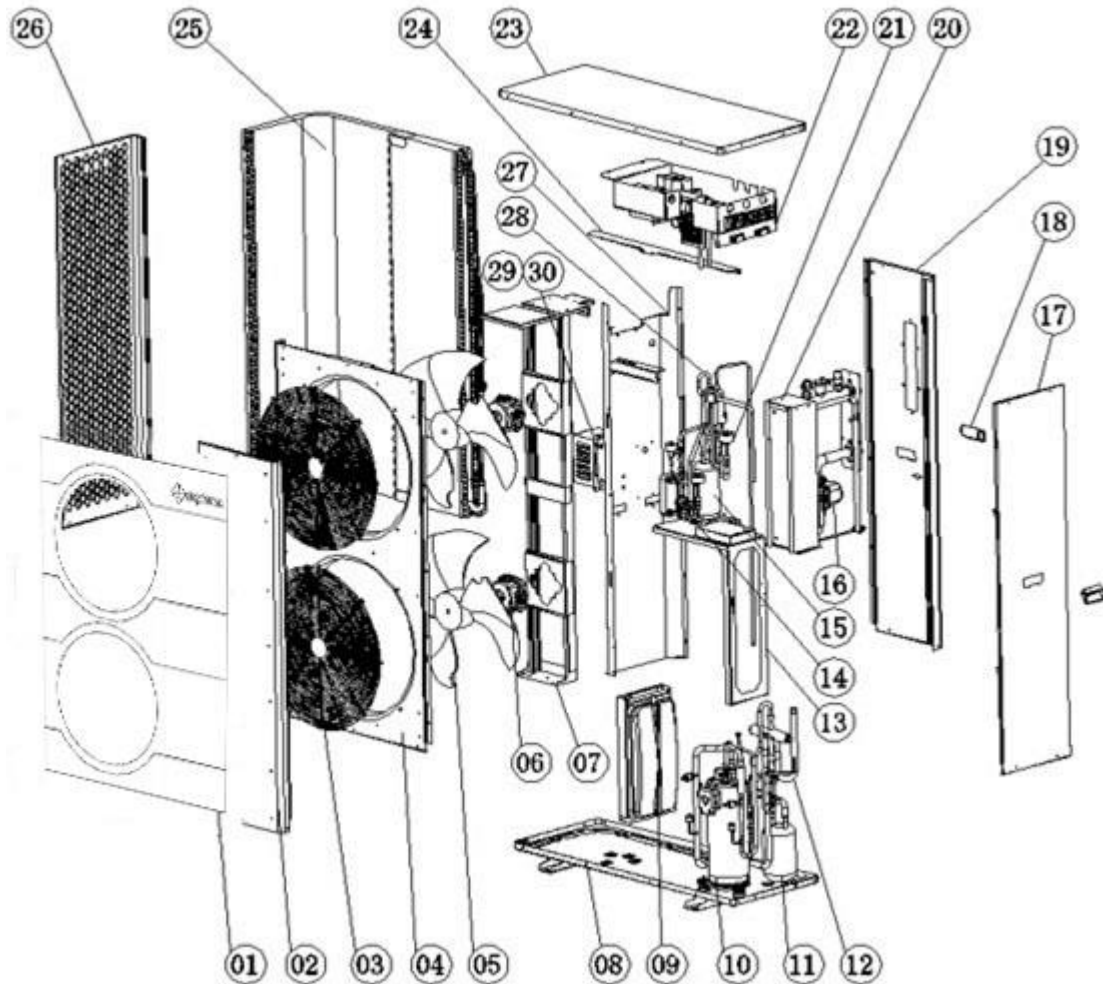

No	Description	No	Description
1	Front Panel	16	Manual valves
2	Fan blades	17	Safety valve
3	DC fan motor	18	Water circulation pump
4	Fan unit fixing	19	Water drain valve
5	Obudowa panel lewy	20	Liquid refrigerant tank
6	Air heat exchanger	21	Liquid/gas separator
7	Centre panel	22	Compressor
8	Electronics	23	Electronic expansion valve
9	Casing top cover	24	Service valves
10	Casing rear panel	25	4-way valve
11	Service panel	26	Economiser
12	Housing right-hand panel	27	High pressure sensor
13	Plate heat exchanger	28	Low pressure sensor
14	Water flow sensor	29	Low pressure switch
15	Automatic air vent	30	High pressure switch

Models: SOL-018HC3, SOL-024HC3

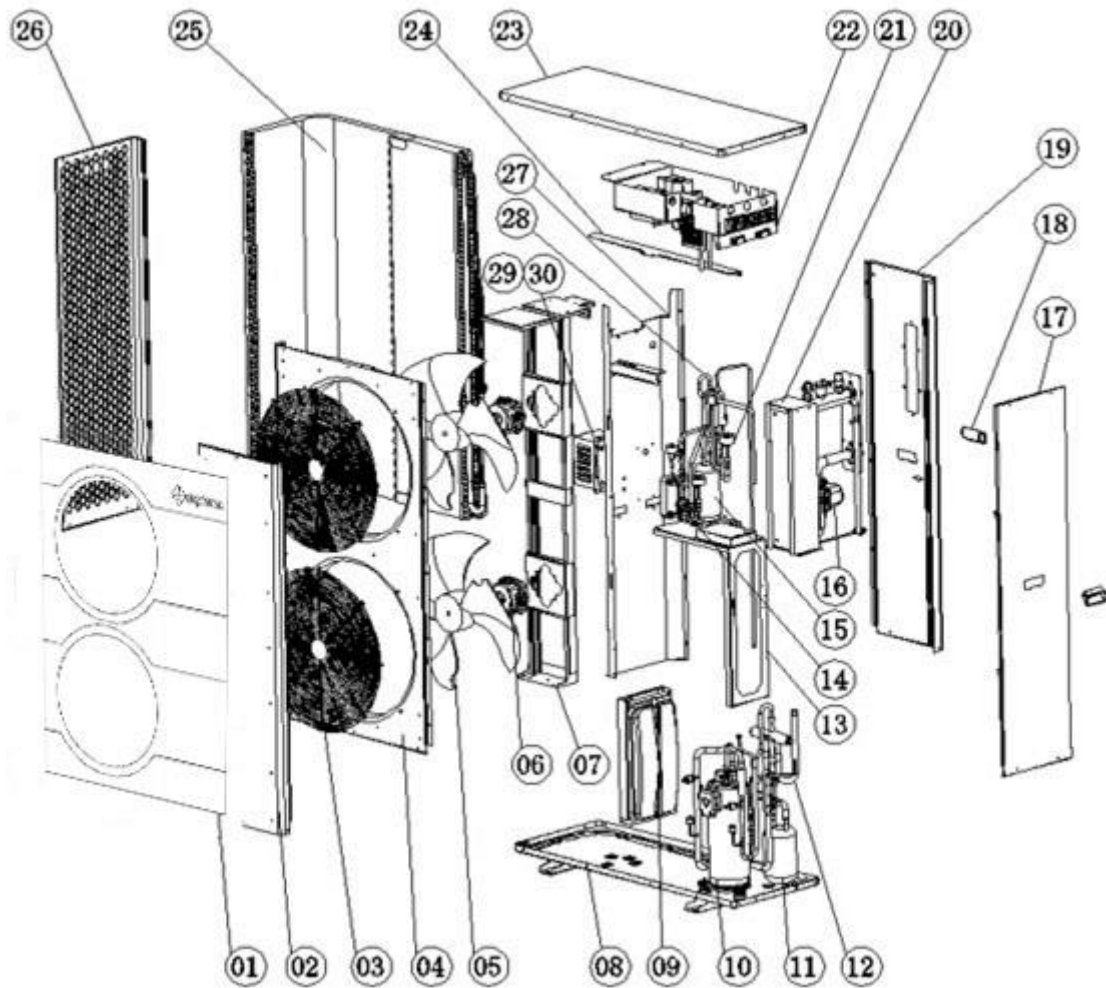

No	Description	No	Description
1	Decorative trim	16	Water circulating pump
2	Casing right-hand front	17	Casing side panel
3	Blow-out dust grill	18	Handle
4	Housing front panel	19	Housing rear panel
5	Fan	20	Plate heat exchanger
6	Fan inverter motor	21	Electronic expansion valve
7	Fan handle	22	Electric box
8	Component base	23	Top cover
9	Expansion tank	24	Evaporator bracket
10	Compressor	25	External evaporator exchanger
11	Liquid separator	26	Casing left side panel
12	4-way valve	27	Separation reinforcement panel
13	Plate heat exchanger mounting	28	Service valves
14	Economiser valves	29	
15	Economizer	30	

1.4 System diagram and performance curve

1.4.1 Schematic diagram of trigeneration refrigeration system

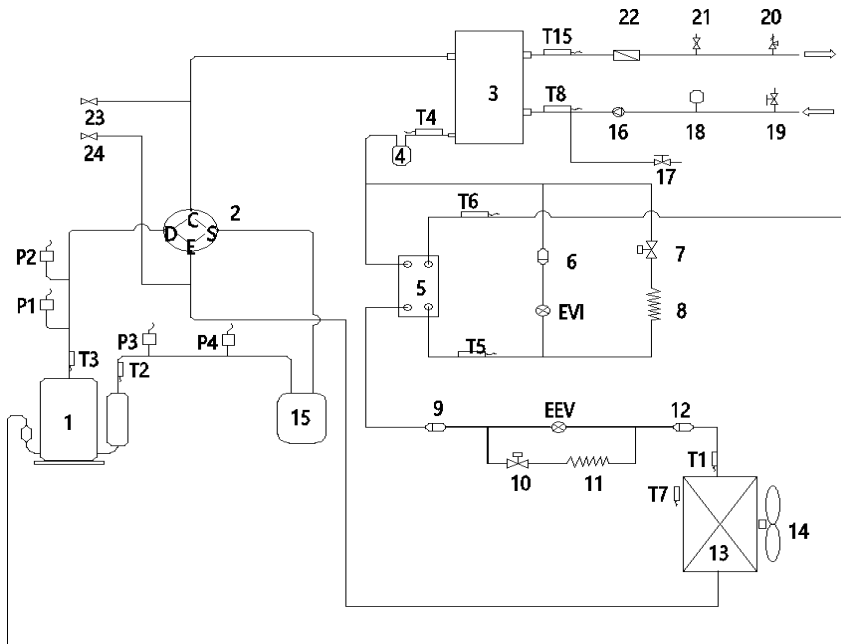

Fig 1-11

Code	Name	Code	Name	Code	Name
1	compressor	15	Gas-liquid separator	T5	Economizer imported temperature sensor
2	4-way directional valve	16	DC circulating water pump	T6	Economizer outlet temperature sensor
3	Plate heat exchanger	17	Manual drain valve	T7	Ambient temperature sensor
4	Reservoir	18*	Expansion tank (non-standard)	T8	Inlet water temperature sensor
5	Economizer	19*	Manual vent valve (not standard)	T15	Outlet water temperature sensor
6	Filter 1	20	relief valve	P1	High pressure pressure sensor
7	Liquid injection solenoid valve	21	Automatic exhaust valve	P2	High voltage switch
8	Liquid spray capillaries	22	Water flow switch	P3	Low pressure pressure sensor
9	Filter 2	23	High pressure maintenance valves	P4	Low voltage switch
10*	Throttle solenoid valve (not standard)	24	Low pressure service valves	EEV	Main electronic expansion valve
11*	Auxiliary throttling capillary (not standard)	T1	Coil temperature sensor	HIS HOME	Auxiliary electronic expansion valve
12	Filter 3	T2	Suction temperature sensor		
13	Finned exchanger	T3	Exhaust gas temperature sensor		
14	Fans	T4	Internal coil temperature sensor		

Description of non-standard models

Models	SOL-006HC1	SOL-010HC3	SOL-014HC3	SOL-018HC3	SOL-024HC3
10 throttle solenoid valve	Yes	No	No	No	No
11 auxiliary throttling capillary	No	No	No	No	No
18 expansion tanks	No	No	No	No	No
19 manual exhaust valve	Yes	Yes	Yes	No	No

Table 1-5

1.4.2 Working principle of heat pump

The heat pump system is mainly composed of four components: compressor, condenser, throttle device and evaporator. Its working principle is to use electric energy to drive the compressor to work, compress the low-temperature and low- pressure gaseous refrigerant into high-temperature and high-pressure steam, and then condense and dissipate heat in the condenser (plate heat exchanger) to release the heat into the heat transfer medium (water). , through the heat transfer medium (water) to provide a heat source to the user end for heating or heating domestic hot water; The condensed medium-temperature and high-pressure refrigerant is throttled by the throttling device and turned into a low-temperature and low-pressure liquid, and then passed through the evaporator (finned heat exchanger) to the air environment Heat absorption is vaporized, forming low-temperature and low-pressure gas, which enters the compressor again to be compressed, thus forming a repeated cycle.

Working principle diagram

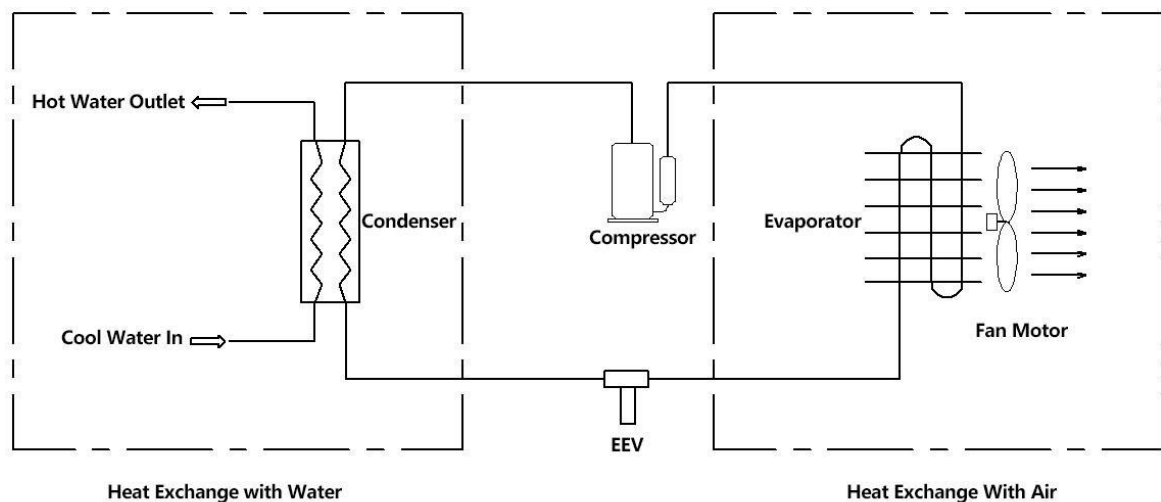















Fig 1-12





1.4.3 Introduction to heat pump system components

Serial number	Image	Name	Function description
1		DC inverter compressor	The compressor is the heart of the heat pump system, it is a "steam pump", the low temperature and low pressure vapor compression into high temperature and high pressure Vapor, which circulates the refrigerant through the heat pump system
2		Plate heat exchanger	Plate heat exchanger is a type of water-side heat exchanger. Used as condenser and evaporator, it is a condenser when heating, condensing the high temperature and high pressure gaseous refrigerant into a liquid state with medium temperature and high pressure, and conducting the condensation heat to the heat exchange medium (water); When refrigerating, it is an evaporator, which evaporates a liquid refrigerant with low temperature and low pressure into a gaseous refrigerant, and absorbs heat in the heat transfer medium (water) during evaporation.
3		Finned heat exchanger	Finned heat exchangers can be used as condensers and evaporators. When heating, it is an evaporator, which evaporates the liquid refrigerant at low temperature and low pressure into a gaseous state to absorb heat in the air. When refrigerating, it is a condenser, which condenses the high temperature and high pressure gaseous refrigerant into a liquid state with medium temperature and high pressure, and dissipates the heat into the air
4		Reservoir	When the heat pump unit is running, the amount of refrigerant circulating in the system will change due to changes in operating conditions or when the cooling capacity is regulated. After setting the reservoir, the reservoir can be used to balance and stabilize the amount of refrigerant circulation in the system, so that the heat pump unit can always operate efficiently and reliably
5		Gas-liquid separator	The refrigerant returning the evaporator to the compressor is separated into gas and liquid, so as to avoid the liquid refrigerant entering the compressor, destroying lubrication or damaging the pump body.

6		Economizer	<p>The economizer is a small plate heat exchanger, its function is to reduce the exhaust temperature of the compressor, improve the compression ratio, and improve the operating stability of the heat pump system at low ambient temperature; By increasing the subcooling degree of the heat pump system, the intermediate compression is carried out with the compressor, and the compressor circulating exhaust volume is improved, thereby improving the capacity and energy efficiency of the heat pump unit.</p>
---	---	------------	---

7		Heat recovery	Increase the subcooling degree of the heat pump system, increase the suction temperature, and improve the capacity and energy efficiency of the heat pump unit
8		Electronic expansion valve	The throttling pressure relief device throttles the liquid refrigerant at medium temperature and high pressure into a liquid refrigerant with low temperature and low pressure
9		4-way directional valve	Change the flow direction of the refrigerant to realize the switching function of refrigeration, heating and defrosting
10		Solenoid valves (liquid injection solenoid valves, throttle solenoid valves)	The solenoid valve is opened and closed to control the flow and disconnection of the refrigerant in the pipeline
11		Pressure sensors	<p>The role of the high-pressure pressure sensor: high-pressure protection of the unit, compressor/fan frequency limiting function control</p> <p>The role of low-pressure pressure sensor: low-pressure protection of the unit, compressor/fan frequency limiting function control, suction superheat control</p>
12		Pressure switch	<p>High-pressure switch: When the exhaust pressure of the heat pump system is higher than the protection value of the high-pressure switch, the high-voltage switch is disconnected, forcing the unit to stop working and avoiding damage to the unit.</p> <p>Low pressure switch: When the suction pressure of the heat pump system is lower than the protection value of the low-pressure switch, the low pressure switch is disconnected, forcing the unit to stop working to avoid damage to the unit.</p>
13		Water flow switch	When the water channel of the heat pump system is cut off or the flow rate is low, the water flow switch is disconnected and the heat pump unit stops working

14	 A brass-colored automatic exhaust valve with a small side port and a threaded bottom.	Automatic exhaust valve	Automatically expel air from the water system
----	---	-------------------------------	---

15		Manual exhaust valve	When the unit is installed for the first time, a small part of the residual air in the pipeline cannot be discharged through the automatic exhaust valve, at this time, it is necessary to manually unscrew the exhaust valve to remove it, and then manually close the exhaust valve after elimination.
16		relief valve	When the pressure of the water system exceeds the design value of the safety valve, the safety valve automatically opens and relieves the pressure, and controls the pressure of the water system not to exceed the specified design value, which plays an important role in protecting personal safety and equipment operation
17		Expansion tank	The expansion tank plays the role of buffering pressure fluctuations and partial feed water in the water system
18		DC circulating water pump	The circulating water pump provides power for the transmission of the heat transfer medium (water) in the heat pump water system, and then takes away the heat in the water-side heat exchanger through the heat transfer medium (water), increasing or lowering the temperature of the heat transfer medium (water).
19		Outdoor fan (DC motor + blade)	The outdoor fan provides strong convection of air during heat exchange in the fin heat exchanger to enhance the heat transfer effect.

20		<p>Maintenance valves (high pressure maintenance valves, low pressure maintenance valves)</p>	<p>The heat pump system drains and charges the refrigerant and evacuates through this valve during maintenance.</p>
----	---	---	---

Table 1-6

1.4.4 Performance curve

Rated Test Conditions:

Heating¹: Ambient Temp 7°C/6°C(DB/WB), Water-In/Out Temp 30°C/35°C

Heating²: Ambient Temp 7°C/6°C(DB/WB), Water-In/Out Temp 47°C/55°C

Cooling: Ambient Temp 35°C/24°C(DB/WB), Water-In/Out Temp 12°C/7°C

SOL-006HC1 Heating performance graph

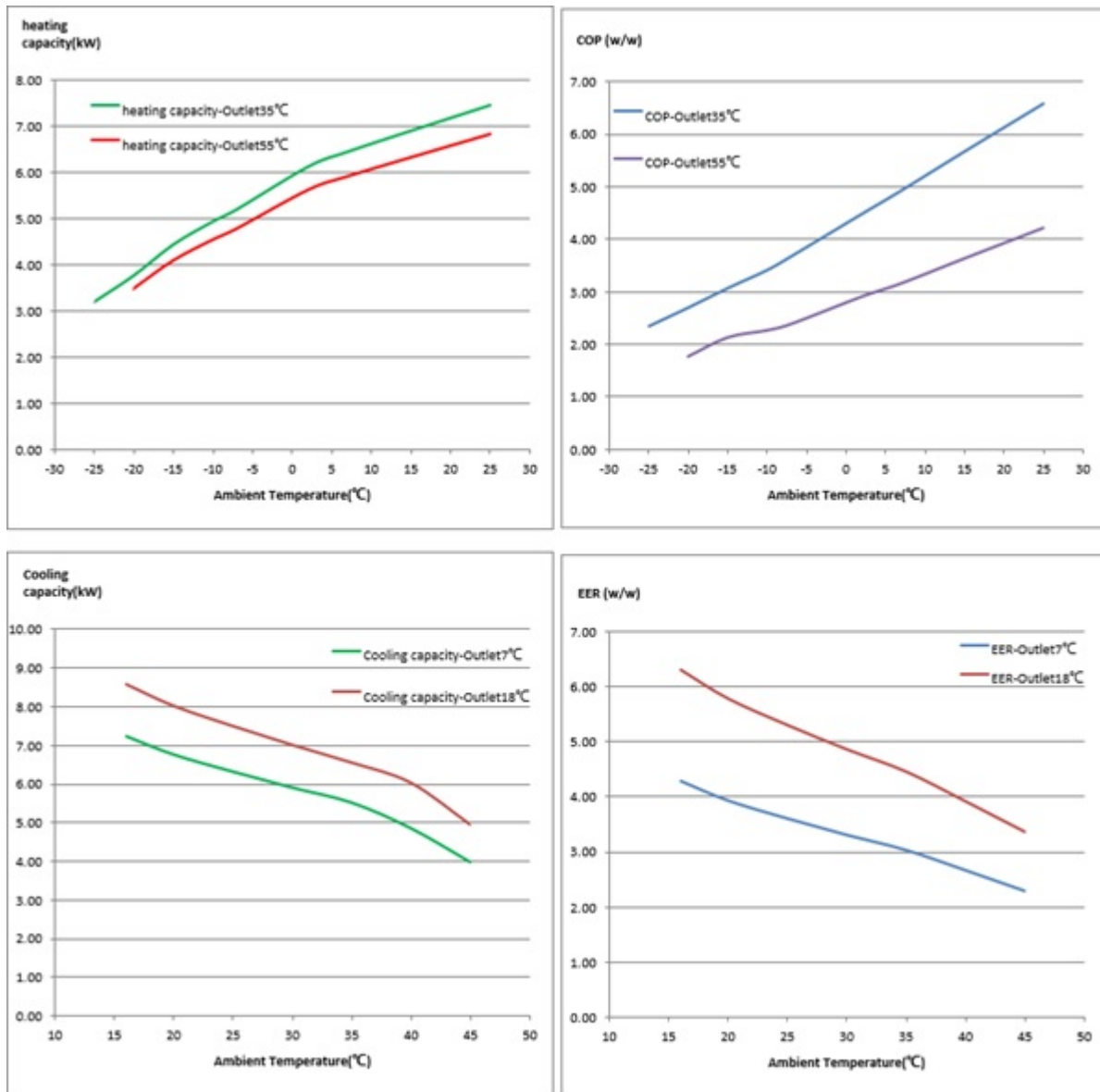

Fig 1-13

SOL-010HC3 Heating performance graph

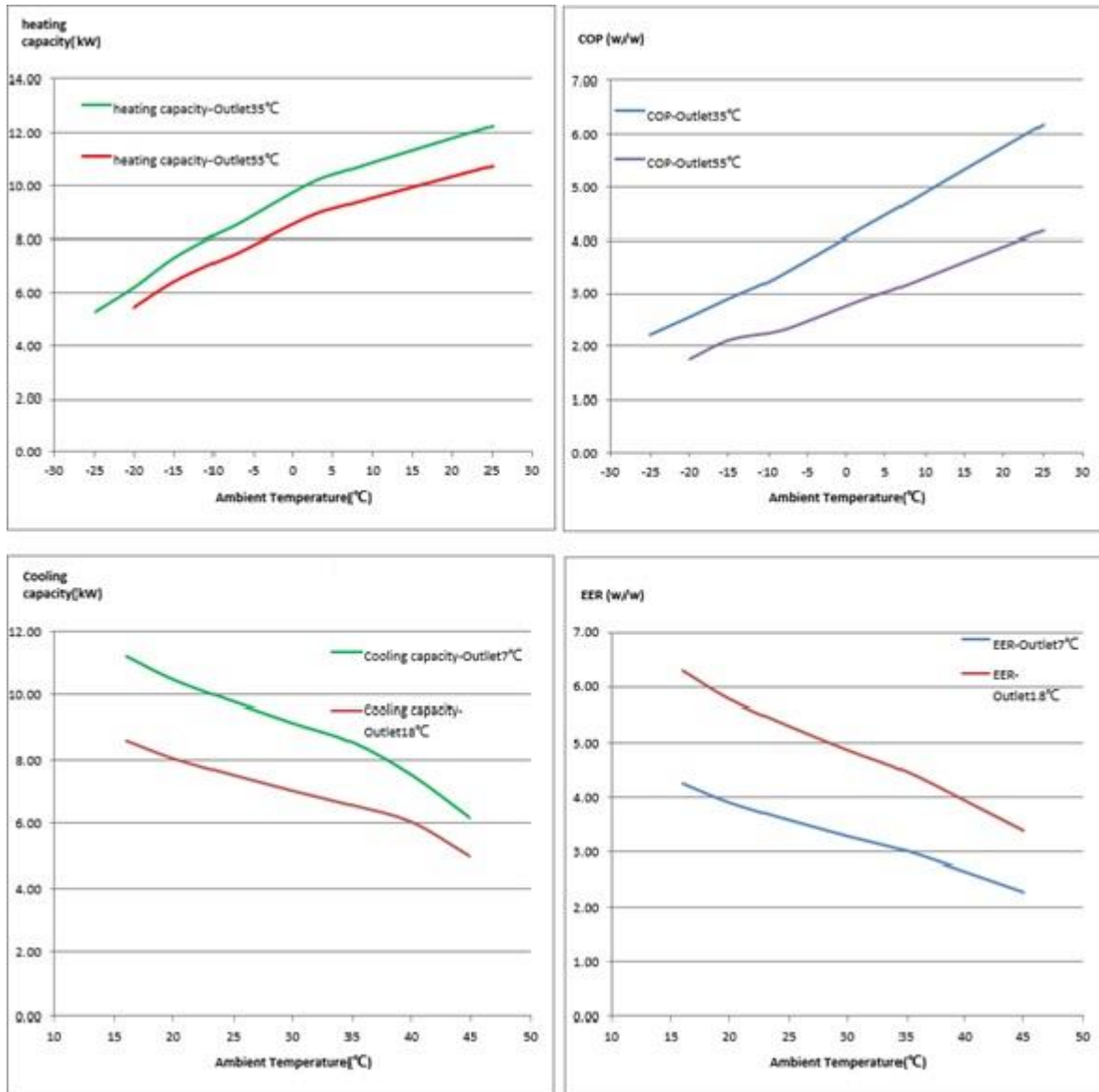

Fig 1-14

SOL-014HC3 Heating performance graph

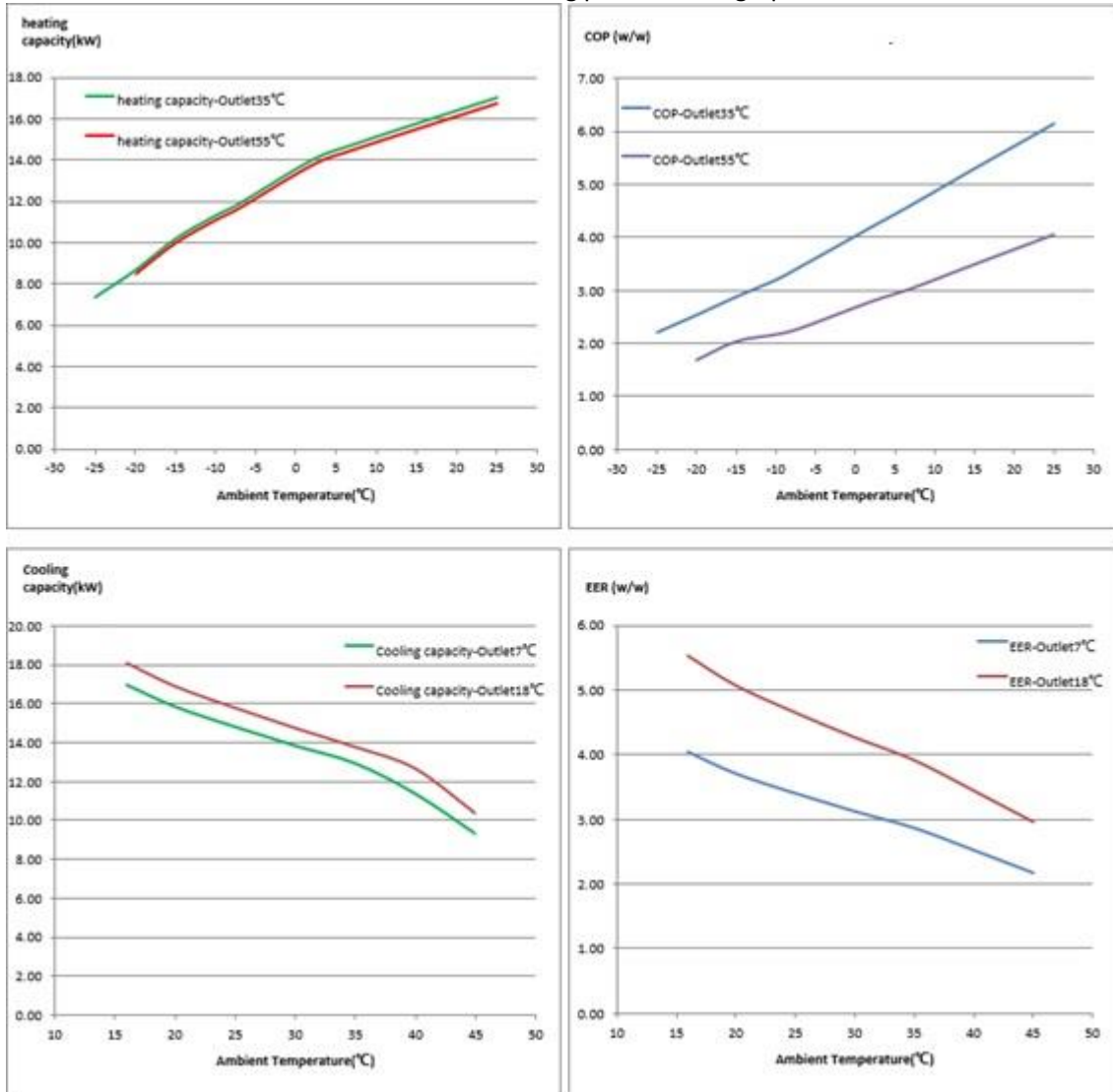

Fig 1-15

SOL-018HC3 Heating performance graph

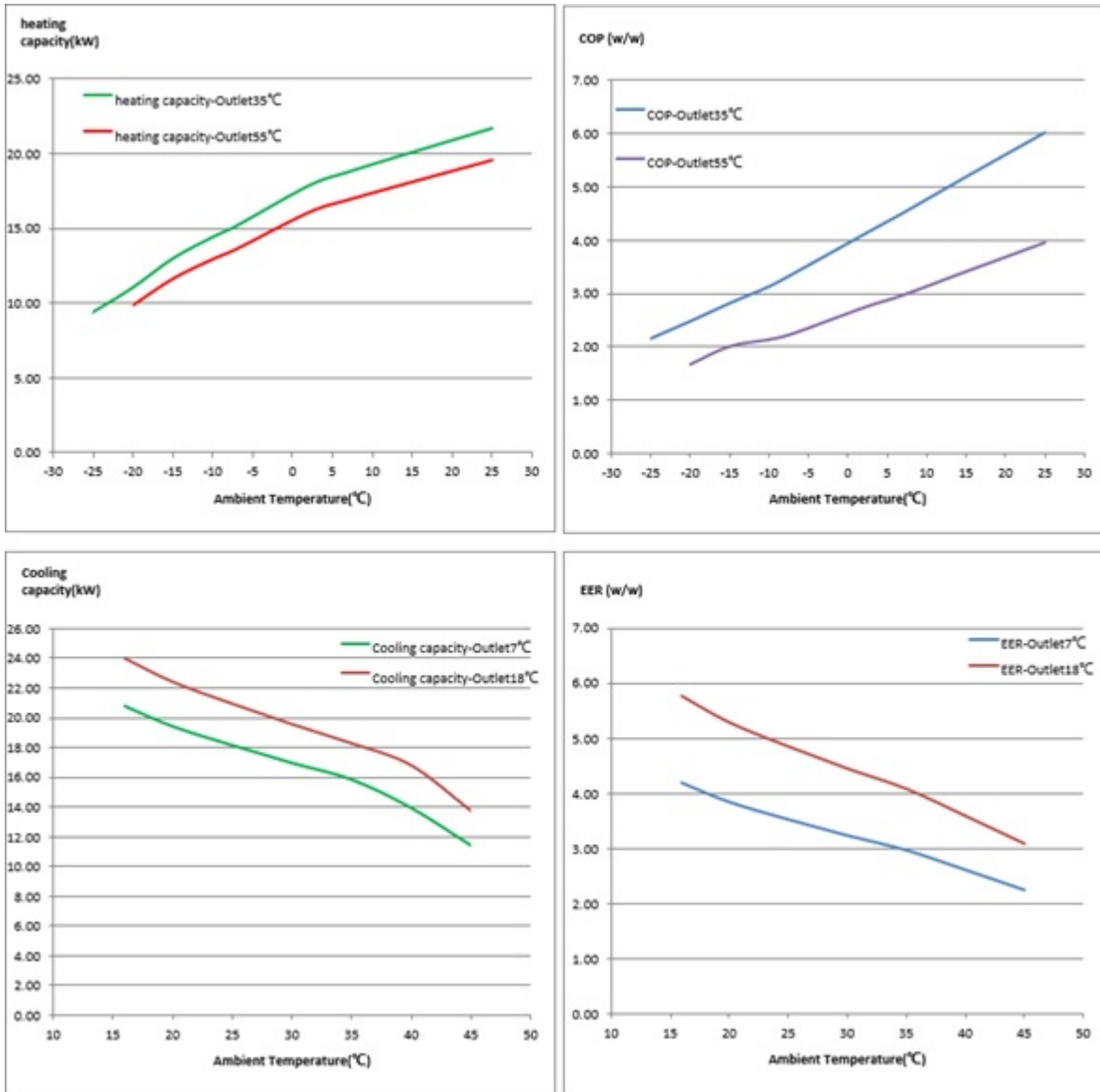

Fig 1-16

1.4.4.1 SOL-024HC1 Heating performance graph

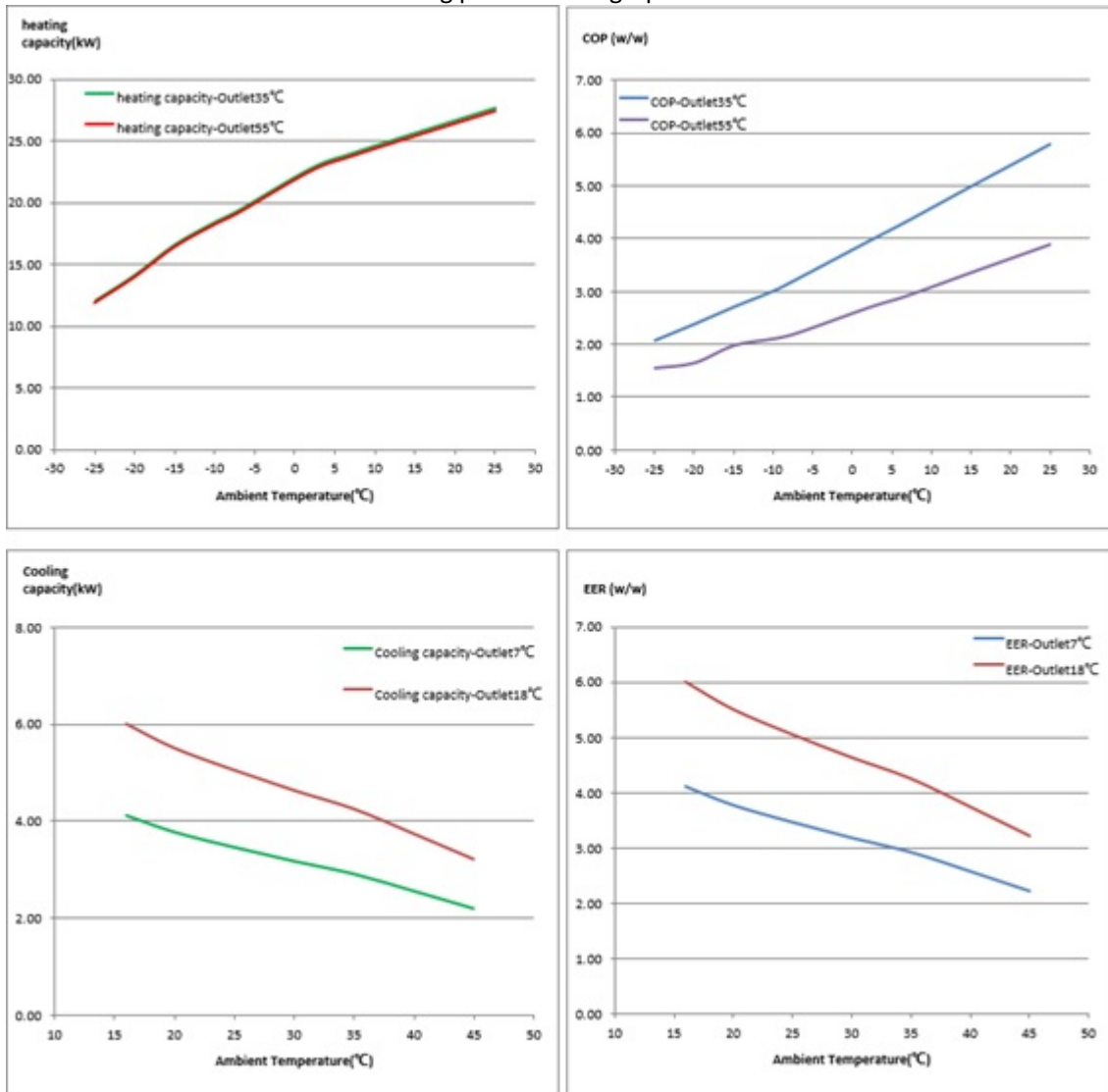

Fig 1-17

Chapter 2: Product selection and installation

2.1 Product installation instructions and special precautions

A. The heat pump cooling and heating water system should be a closed system, if antifreeze or other refrigerant is used, please consult the company;

B. The heat pump unit must be equipped with a filter before entering the pipe, and the mesh of the filter screen is more than 40 mesh;

C. The filter screen in the filter must be made of stainless steel to avoid impurities entering the system after the filter screen is corroded and causing scratches to the heat exchanger.

This heat pump adopts non-toxic micro-combustible refrigerant.

1) Lower limit of ignition [LFL %(v/v)]: 14.4

2) Refrigerant ignition point: 648°C .

Use the following steps to confirm the critical concentration and take the necessary measures.

- Calculate the total volume of refrigerant ($A[M^3]$) = volume of refrigerant in the plant + additional addition.
- Calculate the chamber volume ($B[m^3]$) (as the minimum volume).
- Calculate refrigerant concentration. Prevent excessive concentration. $[A / (A+B)] \leq 14.4\%$

3) Install a ventilator to reduce the refrigerant concentration to a critical level. (Regular ventilation).

4) If regular ventilation is not possible, install a leakage alarm device associated with the ventilator.

2.1.1 Disclaimer

1. This product must use a copper core power line that meets the required wire diameter to supply power independently, and the unit needs to have a reliable grounding wire; If the wiring does not meet the requirements, causing the unit to not work normally, the company is not responsible for this.

2. When cleaning the unit, it must be stopped, cut off the power switch, if the unit is running live to clean it, resulting in electric shock and personal safety injury, the company is not responsible for this.

3. In winter or when the ambient temperature is below 2 °C, if it is not used for a long time, please be sure to drain the water in the waterway and water tank to prevent the water from freezing and expanding, freezing the waterway and water tank and damaging the machine. If the antifreeze protection of the unit is stopped due to power failure, resulting in freezing crack damage of the unit, the company is not responsible for this.

2.1.2 Warning

1. Before installation, it should be confirmed that the grid voltage is consistent with the voltage required by the unit, and whether the through-load capacity of the wire and socket meets the maximum power requirements.

2. If the standing appliance is not equipped with a power cord and plug, and there is no other device that disconnects the power supply (its contact opening distance provides full disconnection under the condition of overvoltage level III), the fixed wiring connected must be equipped with an omnipolar disconnect leakage protection device with a contact opening distance greater than 3mm according to the wiring rules.

3. Please entrust dealers or professionals to install; The installer must have relevant professional knowledge, and if the installation is wrong, it will lead to water leakage, fire, electric shock, injury, etc.

4. The auxiliary items purchased locally must use the company's designated products;

5. Please comply with the regulations of the local electrical company when connecting the power supply; Confirm whether the grounding is correct, if the grounding is not perfect, it may cause electric shock.

6. When the heat pump unit needs to be moved or reinstalled, please entrust dealers or professionals to operate; If installed imperfect, may cause unit operation failure, electric shock, fire, injury, water leakage and other accidents.

7. Never modify and repair by yourself, improper repair, will cause water leakage, fire, electric shock, injury and other accidents, must entrust dealers or professionals to repair.

8. Do not remove any permanent instructions, labels or nameplates on the inside of the heat pump unit shell or various plates.

2.1.3 Precautions

1. The power supply wiring must be equipped with a leakage protector with a rated current value not lower than the high operating current of the unit, and the grounding must be reliable and kept dry to prevent leakage. Please always check whether the wiring is well coordinated, if the contact is poor, it will cause overheating and burn the device, and even cause fire and other personal injury accidents;

2. In places where water may splash and on walls, the installation height of the power socket should not be less than 1.8 meters, and ensure that the water will not splash on the socket, and cannot be installed in places where children may reach;

3. During the heating period, the pressure relief hole of the pressure safety valve may have water droplets dripping, which is a normal phenomenon, if there is a large amount of water leakage,

please find a professional in time to repair, must not block this pressure relief hole, so as not to cause damage to the heat pump unit, resulting in safety accidents. The drain pipe attached to the pressure relief hole should be kept at an inclined downward installation in a frost-free environment;

4. If the unit is equipped with a power cord, the special power cord provided by the manufacturer must be used when the power cord is damaged, and replaced by the manufacturer or the manufacturer's service organization or similar qualified professional maintenance personnel;

5. If the parts of this machine group are damaged, please hand them over to professionals for maintenance and use the special maintenance accessories provided by the company;

6. If the heat pump unit is not used for a long time (more than 2 weeks), hydrogen may be produced in the hot water pipeline system, hydrogen is extremely flammable, in this case, in order to reduce the danger, it is recommended to turn on the hot water faucet for a few minutes before using any electrical appliances connected to the hot water system, if there is hydrogen, then when the water begins to flow, there will be an abnormal sound like air passing through the pipe. Do not smoke near the faucet or light an open flame during the opening period.

7. Do not stick fingers, sticks, etc. into the air outlet or air inlet. Because the internal wind wheel runs at high speed, it may be possible Wounded.

8. When an abnormality occurs (scorched odor), the manual power switch should be cut off immediately, stop running, and serve with the manufacturer's after-sales service Get in touch with the Ministry. If abnormal operation continues, it may cause electric shock to personnel or cause fire.

9. It cannot be installed in places where flammable gases are easy to leak. Once flammable gas leaks, it may lead around the unit Catch fire.

10. Confirm whether the installation foundation is firm for long-term use. If the foundation is not solid, there is a possibility of falling and injuring people.

2.2 Unit installation

2.2.1 Heat pump unit installation

Host installation location requirements:

- The main unit can be installed on the ground, roof, special platform, or anywhere else that is easy to install and can bear the operating weight of the main engine.
- Choose an installation place with good ventilation and smooth exhaust, do not install the host in a polluted, dusty place, do not approach the fire source, power station and other facilities and equipment; There can be no open flame or heat source facilities and equipment with excessive temperature around the host;
- The main engine is as close as possible to the buffer water tank and domestic hot water tank to reduce heat loss.
- There should be a downspout pipe near the main engine for discharging the condensate generated during the work, and take thermal insulation and heating measures to prevent the condensate from freezing and blocking the pipeline;

- The installation location meets the fire protection requirements; The width of the main operating channel of the heat pump unit is 1.0~1.2m, and the width of the non-main channel is not less than 0.8m The distance between the outer outline of the equipment and the switchgear or other electrical devices is 1.0m;
- When the units are installed next to each other, the distance between the two units is maintained at 1.0~1.2m, and the base height of the heat pump unit is more than 0.1m higher than the ground.
- The installation base height of the unit shall not be less than 150mm, and shall be greater than the local snow thickness.
- Set the switch cabinet, control cabinet, etc. in the vicinity of the unit and arrange it centrally.
- Shock absorbers must be installed at the bottom of the unit to prevent vibrations from reaching the building.
- The inlet/outlet of the group and the water system supply and return pipes must be flexibly connected to prevent vibration from spreading from the unit to the building.

2.2.2 Installation of auxiliary water pumps

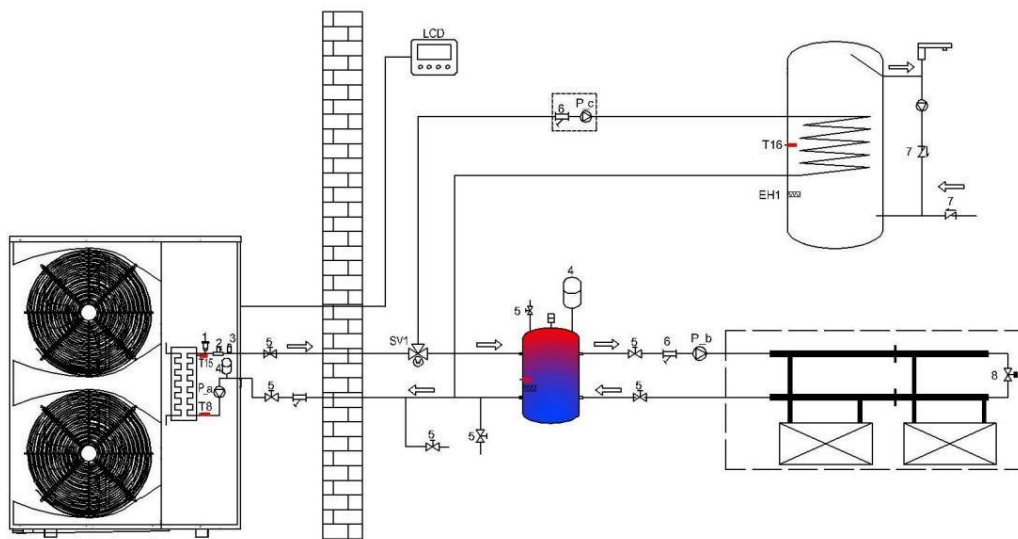

Fig 2-1

Note: For details of the legend description, see Chapter 3.4.1 System Legend Description Comparison

Installation conditions: hot water mode, such as the use of coil water tank for secondary heat exchange heating hot water, the resistance along the way is too large, resulting in the unit reporting water flow switch failure can not be turned on normally, the specific selection needs to be calculated according to the pipeline and the coil of the hot water storage tank.

Installation location: The auxiliary water pump Pc circulates the inlet pipe in the hot water tank, and the control signal is connected from the unit.

2.3 Installation of pipes; Water pressure commissioning; Pipe insulation requirements

2.3.1 Distribution line installation system diagram

2.3.1.1 Schematic diagram of waterway system installation

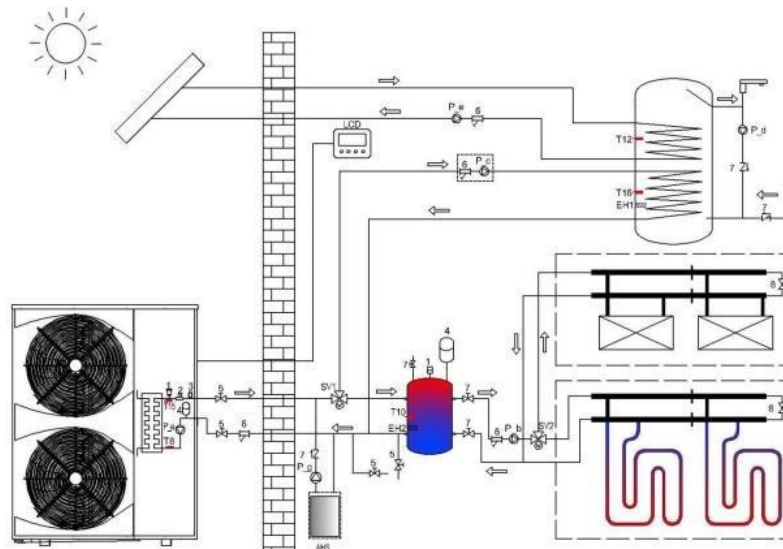

Fig 2-2

Note: For details of the legend description, please refer to Chapter

3.4.1 System Legend Description Comparison

- (1) The same program running pipe is conducive to uniform distribution of water flow;
- (2) The system must be equipped with an automatic water replenishment valve, and the highest point of the water system must be equipped with an automatic exhaust valve;
- (3) The drain valve is installed at the bottom of the pipeline, which is conducive to drainage;
- (4) The automatic exhaust valve is installed at the highest part of the system pipeline, and the water pipe at the installation must have an expanded diameter;
- (5) Normal working water capacity can ensure normal defrosting in winter (ensure that the water capacity per KW exceeds 10L);
- (6) The unit is equipped with a water flow switch, which does not need to be installed during installation;
- (7) In order to facilitate the maintenance of the unit, the outlet pipe of the unit needs to be installed with a pressure gauge;
- (8) If the floor heating adopts chamber temperature control, and the number of collector and distributor circuits in the smallest area is less than or equal to 2, a differential pressure bypass valve is installed according to the schematic diagram;
- (9) If the unit is not operating in winter, the water inside the system must be drained to prevent freezing of pipelines or components.

2.3.1.2 Water quality requirements for unit use

(1) When the water quality is poor, it will produce more scale and sediment such as sand. Therefore, the water used must be filtered and softened with a water softener before flowing into the water system;

(2) Before the use of the unit, the water quality should be analyzed, such as PH value, conductivity, chloride ion concentration, sulfur ion concentration, etc. The following are the water quality standards applicable to this unit.

PH value	Total hardness	Conductivity	Sulfur ions	Chloride ions	Ammonia ions
7~8.5	7~8.5	7~8.5	7~8.5	7~8.5	7~8.5
Sulfate	Sulfate	Sulfate	Sulfate	Sulfate	Sulfate
<50ppm	<30ppm	<0.3ppm	No requirements	No requirements	/

Table 2-1

2.3.1.3 Waterway system installation steps

1. Install all water pipelines;
2. Water pipeline pressure retention leakage detection;
3. Clean the water pipeline.

2.3.1.4 Water line replenishment and pipe emptying steps

1. First open the exhaust valve on the water distributor and all valves;
2. Replenish water at the pipeline water refill port;
3. In the process of replenishing water, it is necessary to observe the exhaust valve, whether the drain valve has water overflow, if there is water overflow, it means that the water in the system has been filled;
4. Close the exhaust valve, and then look at the water pressure gauge, if the pointer is greater than 0.15Mpa, you can close the water replenishment valve and the waterway emptying is completed.

2.3.2 The hydraulic test of hydraulic pressure debugging shall comply with the following regulations

Before the test, the pipeline should be fixed, the joints should be exposed, and the water distribution appliances should not be connected;

1. The pressure gauge is installed at the lowest point of the test pipe section, and the pressure accuracy is 0.01Mpa;
2. Slowly fill the pipeline with water from the lowest part of the pipe section, fully exclude the air in the pipeline, and carry out the water tightness test;
3. Slowly boost the pipeline, and use a manual pump for booster boosting, and the boost time is not less than 10min;
4. After the pressure is boosted to the specified test pressure, the pressure is stabilized for 1 hour, and the pressure drop shall not exceed 0.06Mpa;
5. In the state of 1.15 times the working pressure, the pressure is stabilized for 2 hours, and the pressure drop shall not exceed 0.03Mpa;
6. During the test, there shall be no leakage at each connection;
7. Allow two make-up pressures within 30 minutes to rise to the specified test pressure.

2.3.1.6 Pipe insulation requirements

1. All hot water pipes must be wrapped with thermal insulation materials;
2. Wrap the insulation pipe flat on the hot water pipe and then wrap the cable tie;
3. Wrap the insulation skin (such as thin aluminum plate, aluminum foil, etc.) on the pipe that has been wrapped with the insulation pipe;
4. The wall thickness of the insulation pipe should be reasonably selected according to the local climate, and the DN20 pipe uses insulation cotton with a thickness of more than 10mm; Finally, wrap a layer of wrapping tape on the insulation cotton.

2.4 Electrical wiring considerations

1. The outdoor special power cord should be used, and the power supply voltage should meet the rated voltage requirements;
2. The power supply line of the unit must have a grounding wire, and the power ground wire must be reliably connected with the external grounding wire, and the external grounding is effective.
3. The user's incoming power supply must be installed with a leakage protection device.
4. The wiring construction must be connected by a professional installation technician according to the circuit diagram.
5. The arrangement of power line and signal line should be neat, reasonable, and cannot interfere with each other, and at the same time do not contact with the connecting pipe and valve body to ensure that the minimum distance between strong and weak electricity is more than 25mm.
6. The wire controller should be installed in a place where it is easy to observe the operation,

and should not be installed in a place with water and moisture.

7. Each connecting cable in the host is installed at the factory, and the user does not need to connect again, just check whether the connecting cable is connected normally, whether it is damaged or falling off.

8. The line connecting the temperature probe and controller is not long enough, and the connection can be appropriately extended, and the total length does not exceed 20 meters. Note that the connection should be firmly bandaged and waterproof and insulated.

9. High-voltage side cable: unit power line, water pump power line, electric heating power line, solenoid valve power line, etc. need to use anti-aging, corrosion-resistant power cord suitable for outdoor power line (H07RN-F type or higher).

10. Users need to equip their own power cord, please choose copper core power cord, copper core power cord wire diameter should not be less than the following specifications; If the user's power distribution capacity is insufficient or the outdoor power cord (copper core wire) is not configured as required, resulting in the unit not being able to start or operate normally, the company shall not be responsible for the corresponding responsibility.

Important: Always ensure that the heat pump power supply is in a disconnected state before proceeding with any electrical installation work.



Electrical specifications recommended

Model	SOL-006HC1	SOL-010HC1	SOL-010HC3	SOL-014HC1	SOL-014HC3	SOL-018HC1	SOL-018HC3	SOL-024HC3
Power supply V/Hz	230V/50 Hz	230V/50Hz	400V/3N~50 Hz	230V/50Hz	400V/3N~50 Hz	230V/50Hz	400V/3N~50 Hz	400V/3N~50 Hz
Maximum power KW	2.71	3.83	3.83	6.20	6.20	7.50	7.50	10.00
Maximum current A	12.00	17.00	6.50	27.50	10.50	35.00	13.00	17.00
Air switch A	16	25	16	40	16	50	20	25
The minimum wire diameter of the power supply AWG	3*13AWG	3*12AWG	5*14AWG	3*10AWG	5*13AWG	3*9AWG	5*12AWG	5*11AWG

2.5 Room heat load calculation

2.5.1 Basic Requirements

The heat load of the winter heating system shall be determined based on the heat lost and obtained from the building below:

- 1) heat consumption of the envelope;
- 2) Heat consumption of cold air that penetrates into the room from the gaps in the exterior doors and windows;
- 3) Heat consumption of cold air entering the room through the outer door when the outer door is opened;
- 4) Ventilation heat consumption;
- 5) Heat lost or acquired through other means.

Note: The amount of heat dissipation that is not often used when calculating the heat load can not be calculated; Frequent and unstable heat dissipation should be used as an hourly average. At present, the area of residential buildings is getting larger and larger, the heat generated inside the unit building area is different, and the heat dissipation of cooking, lighting, home appliances, etc. is intermittent, and this part of the free heat can be used as a safe amount and is not considered when determining the heat load. The heat dissipation of larger, more constant heat dissipation objects in public buildings should be taken into account when determining the heat load of ventilation systems.

Simple estimation of heat load

Heating loads can be recommended according to the table below:

Climatic conditions	Warm climate zone		Average climate		Cold climate zone	
Calculate the climate temperature °C	7		0		-12	
Enclosure insulation	not	be	not	be	not	be
Heating load (W/m ²).	80-100	40-60	100-120	40-60	120-150	40-60

Table2-3

Note: This thermal index has included the heat loss of the pipe network, accounting for about 5%;

Note: The load of some special places (such as glass wall exhibition halls, etc.) should be increased as appropriate to ensure the effect.

When calculating the heat load of the comprehensive ground radiant heating system, the value of the indoor calculated temperature should be 2 °C lower than the indoor calculated temperature of the convection heating system, or 90%~95% of the total heat load calculated by the convection heating system. Suitable design room temperature is 20°C.

When floor radiation is used for local district heating of the room and other areas are not heated, the heat dissipation required for floor radiation can be determined by the heat dissipation required for comprehensive radiant heating, multiplied by the calculation coefficient of Table 1-2 "Calculation coefficient table of heat consumption of radiant heating in local areas".

Table of calculation coefficients for heat consumption for radiant heating in local areas

The ratio of the heating area to the total area of the room	≥0.75	0.55	0.4	0.25	≤0.20
Calculate the coefficients	1	0.72	0.54	0.38	0.3

For rooms with a depth greater than 6m, it is advisable to divide 6m from the outer wall, calculate the heat load and arrange the heating parts separately.

The heat transfer heat load of the ground should not be calculated when laying the floor of the building where the heating components are laid.

When the height of a room with floor heating (excluding stairwells) is greater than 4m, the height surcharge rate should be calculated based on the sum of the basic heat consumption and the additional heat consumption of the orientation, wind power, and external door. Every 1m higher should be added 1%, but the maximum additional rate should not be greater than 8%.

Floor heat dissipation and system heat supply calculation According to the room heat load, the radiant heat dissipation of the room floor can be calculated. (Calculate the geothermal pipe spacing for laying heating pipe ground area, water temperature, indoor temperature, etc.).

Amount of heat dissipation required per unit floor area:

$$q_1 = \frac{Q_1}{F_r}$$

$Q_1 = Q - Q_2$

Formula q_1 - heat dissipation per unit floor area (W/m^2);

Q_1 - the effective heat dissipation required upwards in the room (W);

F_r - the floor area (m^2) in the room where heating components are laid;

β - consider the safety factor of furniture and other occlusion (recommended value 1.1-1.2);

Q - room heat load (W), it can be calculated according to the recommended value of Table 1-1;

Q_2 - heat dissipation loss from the floor of the upper room downward (W);

For a fully ground heating room, the heat dissipation per unit area of the ground and the interior design temperature should be within the appropriate range for the average surface temperature required by the room, and should not be higher than the maximum limit of 28°C. When the calculated local surface temperature is too high, the following measures can be taken:

Improve the thermal performance of the building envelope;
additional heating equipment;

Under the condition of satisfying comfort, appropriately reduce the indoor calculation temperature.

2.5.2 Water system design

Precautions for central heat source heating:

For residential buildings using centralized heat sources, the design of the heating system in the building should

meet the following requirements:

It should be in the form of a separate system with a shared riser.

The same riser should be connected to indoor systems with similar loads.

The number of households connected by a pair of shared risers on each floor should not exceed 3, and the total number of indoor systems connected by shared risers should not exceed 40.

The supply and return pipes connected to the indoor system of the common riser should be set up with shut-off valves respectively, and one of the shut-off valves should have an adjustment function, and a static balancing valve should be used.

Shared risers and separate household shutdown regulating valves should be installed in pipe wells or small rooms in outdoor public spaces.

The primary water distributor, water collector of each household, and heat exchanger or water mixing device if necessary, should be installed indoors.

Stand-alone heat source heating considerations

For indoor systems with independent heat sources, the flow rate and head of the circulating water pump should meet the needs of the indoor heating system;

The constant pressure value of the system should meet the pressure bearing requirements of the heating pipe or prefabricated light and thin heating plate.

2.5.3 Water divider and water collector configuration principle

The length of each loop connected to the same pipe diameter of the same water distributor and water collector should be close;

When laying heating tubes on site, the length of heating tubes in each loop should not exceed 120m;

The total length of the supply and return pipes of each transmission and distribution pipe of the prefabricated light and thin heating board should not exceed 50m;

When the length of each loop is large, it is advisable to use heating tubes with different pipe diameters, or set up balancing devices on each branch loop.

2.5.4 Selection of floor heating heat pump units

1. Calculate the heat load of the room design

Room design heat load = additional coefficient × floor heating area × heat load

The additional coefficient is the ratio of the floor heating area to the total room area, which is selected according to the table below:

The ratio of heating area to total room area	>0.55	0.4-0.55	0.25-0.4	<0.25
Additional coefficients	1.0	1.3	1.35	1.5

Table2-5

Note: The additional coefficients in the above table are standard recommended values, and specific adjustments should be made according to the actual situation in the actual project.

2. Check the heat dissipation of the floor

According to the above calculation of the floor heat dissipation, the deviation from the room design heat load should not exceed 5%. The main purpose is to calculate whether the heat dissipation meets the heat load of the room when the floor surface temperature does not exceed the limit.

3. Determine the heat source heating load

The heat source heating load is the sum of the heat dissipation of the ground and the heat loss of the ground downward or soil. Downward heat loss refer to Schedule A.

4. Selection of type spectrum

According to the performance curve of 1.5.4 of the type spectrum, multiply the safety factor of 1.1~1.2 to select the appropriate unit.

5. Selection of auxiliary accessories for floor heating

5.1 Circulating water pump

Basic principles:

- 1) It should meet the larger value of the flow rate and head required by the system's design heating condition in winter and refrigeration condition in summer.
- 2) When the head of the supporting water pump of the unit used is less than the system resistance, the series water pump should be added.
- 3) Select the most unfavorable water system loop, carry out hydraulic calculation, and select the circulating water pump according to the total head loss, considering the margin.

5.2 Pump head

To calculate the resistance loss of the buried pipe for floor heating, select the head of the pump. The hydraulic calculation formula of floor heating plastic pipe is:

$$\sum P = \sum P_m + \sum P_j$$

A Resistance calculation along the way

$$\sum P_m = R \cdot l$$

B Local resistance calculation

$$\sum P_j = \sum \frac{\rho v^2}{2}$$

The above can be calculated in detail according to the hydraulic calculation table to find out the relevant parameters.

It can also be estimated by the following formula:

Head $H = K \cdot ($ height difference between pipelines $h(m) +$ unit water side pressure loss $+)$ longest pipeline

length (m)* 0.07)

Remark:

1) K is the safety factor value 1.1-1.2; Take 1.1 for single-channel water systems and 1.2 for multi-channel water systems

2) Water-side pressure loss unit kPa, 10kPa=1m (H₂O) head;

3) When the unit has its own pump, the auxiliary pump lift should be subtracted from the pump head of the corresponding unit according to the calculated value

5.3 Flow rate of the pump

The floor heating pump is selected according to 1.2 times the total flow rate of the system.

5.4 Expansion tank

Basic requirements: rust proof, suitable for water/glycol (up to 30%) solution.

General specifications:

Expansion tank specifications

Volume (L).	2	4	5	8	12	18	19	20
Preset pressure (bar).	1.5 ~	1.5 ~	1.5 ~	1.5 ~	1.5 ~	1.5 ~	1.5 ~	1.5 ~
Maximum pressure (bar).	10	10	10	10	10	10	10	10
Interface pipe diameter	3/4"	3/4"	3/4"	3/4"	3/4"	3/4"	3/4"	3/4"
Maximum operating temperature	70	70	70	70	70	70	70	70

Table2-6

Calculate the selection:

$$V = \frac{C \times e}{1 - \frac{P1+1}{P2+1}}$$

Formula:

V: Volume of the expansion tank, unit: L

C: The total capacity of water in the system (including boilers, pipes, radiators, etc.), unit: L

e: The coefficient of thermal expansion of water, see Appendix B of the expansion coefficient table of water at different temperatures.

P1: The pre-charge pressure of the expansion tank, unit: bar, this pressure cannot be lower than the system static pressure at the installation point of the expansion tank.

P2: The highest pressure at which the system operates (i.e. the starting pressure of the safety valve in the system), unit: bar,

The height difference between the expansion tank and the safety valve needs to be considered.

Note: All pressures in the above formula are relative pressures (that is, gauge pressure), and the selection principle is to choose large rather than small.

Expansion tank installation schematic

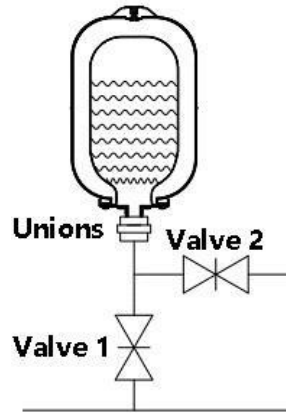

Fig 2-3

5.5 Filter

The water filter must be installed at the water return port of the heat pump unit, which can reduce the impurities in the pipeline entering the filter and protect the normal energy-saving operation of the unit.

Basic requirements: the material is brass or stainless steel, brass is recommended, the filter is stainless steel, and it is suitable for water/glycol (up to 30%) solution.

General specifications:

Filter specifications

Interface pipe diameter	1" F	1.1/4" F	1.1/2" F	2" F
Number of filter meshes	40	40	40	40

Table 2-7

Selection suggestion: The role of the filter is to collect the materials in the system and avoid the materials affecting the normal operation of the system. The larger the number of filter meshes, the finer the particle size of the material, and the smaller the mesh number, the larger the particle size of the material. The diameter of the filter should be consistent with the outer diameter of the main water supply pipeline of the system or one specification larger than the outer diameter of the pipeline.

Installation suggestions: the filter must choose the appropriate position, the water flow direction of the system must be consistent with the direction of the arrow on the filter, for the filter with the sewage valve, the sewage valve must be down, incorrect installation will lead to the inability to remove the garbage in the filter screen through the sewage valve, and these garbage long-term retention in the filter screen will lead to a decrease in the effective area of the filter screen, and the water resistance generated by the filter screen will increase. The water flow of the system is reduced.

5.6 Relief valve

Safety valves are generally installed in thermal systems such as air conditioners, boilers, heat pumps, etc. and are generally installed at the return end of the system.

Basic requirements: Brass or stainless steel, suitable for water/glycol (up to 30%) solutions.

General specifications:

Safety valve specifications

Interface dimensions	1/2"MF	1/2"FF
Set the pressure (bar).	1.5/2.5/3	1.5/2.5/3

Table2-8

Selection suggestions: the safety valve in the system to play a role in safety protection, when the system pressure exceeds the specified value, the safety valve opens, part of the hot water in the system is discharged from the system, so that the system pressure does not exceed the allowable value, so as to ensure that the system does not have an accident due to excessive pressure. The set pressure (starting pressure) of the safety valve is consistent with the maximum working pressure of the system. Generally, the parameters provided by the equipment provider can be referenced.

5.7 Electric 3-way valve

Basic requirements: Brass, stainless steel or plastic, suitable for water/glycol (up to 30%) solutions.

Selection suggestions:

Wiring mode: three wires and two controls;

Drive voltage: AC220V

Action time: 15s

Medium temperature: 2-95°C

Nominal pressure: 1.6Mpa

Wiring schematic:

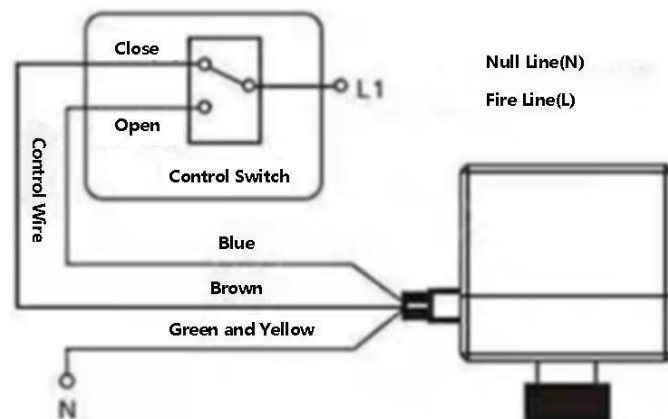

Fig2-4

5.8 Make-up valve (manual or automatic)

Basic requirements: Brass or stainless steel, suitable for water/glycol (up to 30%) solutions.

General specifications:

Make-up valve specifications

Interface dimensions	1/2"MF	1/2"FF	3/4"M1/2"F	3/4"M1/2"M
Maximum inlet pressure (bar).	3	3	3	3
Pressure regulation range (bar).	0.3~3	0.3~3	0.3~3	0.3~3
Factory-preset pressure (bar).	1.5	1.5	1.5	1.5

Table2-9

Selection suggestions: The pressure setting of the automatic water filling valve is higher than the static pressure of 0.3bar, but the set value needs to be lower than the water replenishment pressure (inlet pressure), otherwise it cannot be replenished normally.

5.9 Exhaust valve (manual or automatic (recommended))

Basic requirements: Brass or stainless steel, suitable for water/glycol (up to 30%) solutions.

General specifications:

Exhaust valve specifications

Interface dimensions	1/4"M	3/8"M	1/2"M
Maximum working pressure (bar).	8	8	8
Maximum operating temperature (°C).	90	90	90

Table2-10

Selection suggestions: Because water is usually dissolved in a certain amount of air, and the solubility of air decreases with the increase of temperature, so that the water gradually separates from the water during the circulation process, and gradually gathers together to form large bubbles or even gas columns, because there is water supplementation, so there is often gas produced. During the operation of the heat pump system, many adverse effects caused by the gases released by the water during heating, such as oxygen, will damage the system and reduce the thermal effect, and these gases will have many adverse consequences if they cannot be discharged in time.

5.10. Buffer tank selection

The plumbing system needs to consider the influence of the system water capacity on the stability of the system, and the biggest influencing factor for the air source heat pump heating system is the defrosting of the unit in winter. The defrosting time of the air source heat pump unit is 3-8min, and the defrosting time is taken 4min to calculate the volume of the energy storage tank, and when running in winter, the defrosting time of the host is 4min, and the water supply temperature is allowed to be reduced not to exceed 3°C.

Install a buffer tank on the water system return main to buffer the water system temperature fluctuations. The buffer water tank adopts the pressure-bearing type, the maximum working pressure is $\geq 7\text{bar}$, and the nozzle size is according to the main pipe size.

Selection calculation:

Total water volume in the heating system:

$$V1=Q*t/(C*\Delta T)$$

In the formula:

Q-----Customized heat for the unit, unit kW;

ΔT ----- water temperature drop, unit $^{\circ}\text{C}$, generally take 3°C ;

t----- the defrosting time of the unit, take 240s

C ----- the specific heat of water is $4.2\text{ (kJ / (kg}\cdot^{\circ}\text{C))}$.

The amount of water in the heating line:

$$V2=\pi*d^2*L/4000$$

π -----is the pi constant, take 3.14;

d-----inner diameter of pipeline, unit m;

L ----- The total length of the pipeline, subject to the actual engineering installation, unit m

Buffer tank capacity $V=V1-V2$

table for buffer tank selection

Model	BLN-006TB1	BLN-010TB1/3	BLN-014TB1/3	BLN-018TB1/3	BLN-024TB1/3
The recommended capacity of the heating water tank is L	50-70	80-100	100-150	150-200	200-250

Table2-11

5.11. Hot water tank selection

Hot water tank capacity calculation,

$$V=Q*t*3600/(C*\Delta T)$$

Formula:

Q-----Customized heat for unit amount, unit kW;

t-----Unit heating time1-2h, It is recommended to take1.5h, to prevent affecting hot water or heating use;

ΔT ----- Hot water temperature difference, unit $^{\circ}\text{C}$, generally take 40°C ;

C---- Specific heat extraction of water $4.2\text{ (kJ / (kg}\cdot^{\circ}\text{C))}$

V----- Tank volume, unit L

5.12. Hot water tank inner coil selection

Household hot water is usually heated by built-in coil, so the specification selection of the inner coil directly affects the heating effect and the reliability of the unit.

The specifications of the built-in coils are shown in the table below:

Material		Stainless steel SUS316L			20# steel + outer surface enamel		
Pipe	Light tubes	22	28	32	22	28	32
diameter	Bellows	22	28	32	/	/	/

Table 2-12

Selection calculation: According to experience, the heat exchange q per unit area of the light tube is 3KW . The heat exchange q per unit area of bellows is 6KW

$$S=Q/q$$

Formula: S is the outer surface area of the inner coil unit m^2 ;

Q customizes the thermal capacity for the unit;

q is heat exchange kW/m^2 per unit area

Coil length $L=S/(\pi*d)$.

Formula: S is the outer surface area of the inner coil unit m^2 ;

π is the pi constant;

d is the diameter of the tube in m

Calculate the appropriate tube length according to the above formula.

Note: If the bellows inner coil is used, the resistance loss of the water system increases, please pay attention to the reason of the circulating water pump.

5. 13. Water pump connection Fig :

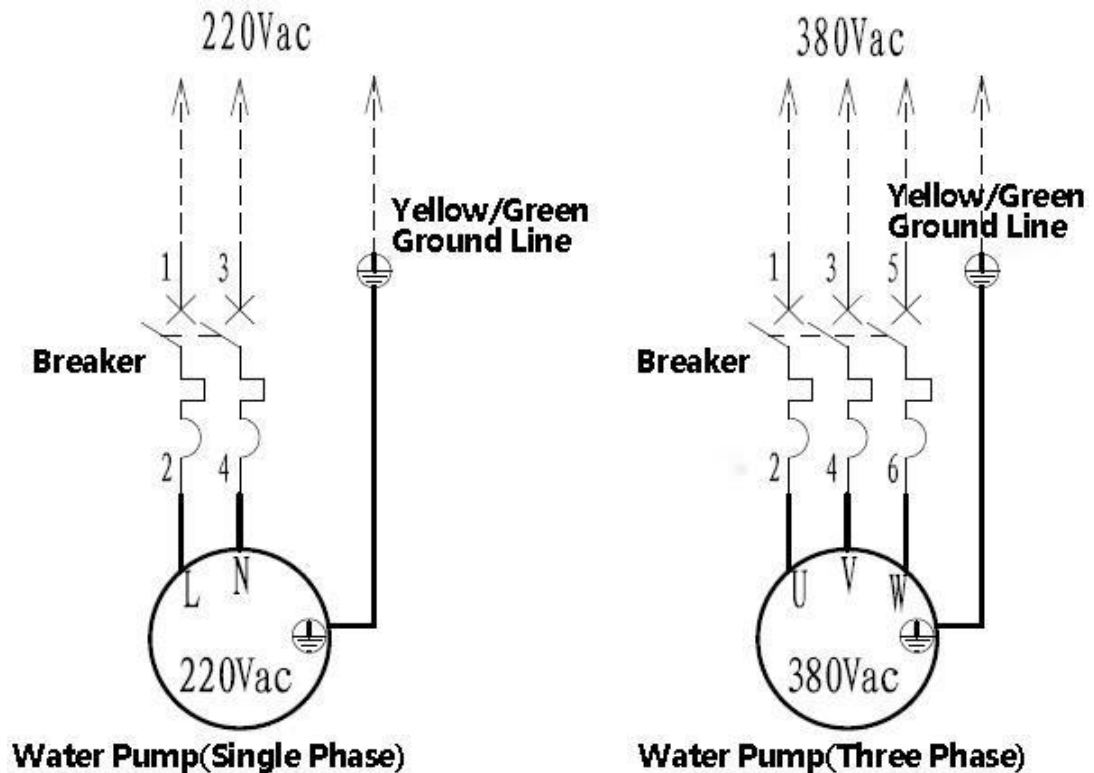

Water pump wiring diagram Fig 2-5

Selection: Circuit breaker (C/D series) rated current \approx 1.2* rated current of water pump

Copper core power cord: 1.5mm² below 5A

5A~12A choose 2.5mm²

12A~20A choose 4mm²

5.14. Water quality requirements (refer to the "Technical Regulations for Water Quality and Anti-corrosion of Heating and Heating Systems").:

Requirements for water quality		Replenish water	Circulating water
Suspended solids mg/l		≤ 5	≤ 10
PH(25°C)	Steel equipment		10-12
	Copper equipment	≥ 7	9-10
	Aluminum equipment		8.5-9
Total hardness	mmol/L	≤ 6	≤ 0.6
dissolved oxygen	mg/L	--	≤ 0.1
Oil content	mg/L	≤ 2	≤ 1
CL-m g/l	Steel equipment	≤ 300	≤ 300
	AISI 304 stainless steel	≤ 10	≤ 10
	AISI 316 stainless steel	≤ 100	≤ 100
Sulfate SO ₃ -	Copper equipment	≤ 100	≤ 100
	Aluminum equipment	≤ 30	≤ 30
	mg/L	--	≤ 150
Total iron	So so	--	≤ 0.5
	Aluminum equipment		≤ 0.1
Total copper	So so	--	≤ 0.5
	Aluminum equipment		≤ 0.02

1. During the operation of the heat pump unit, it is necessary to regularly (it is recommended to sample and analyze the water quality every six months), if the water quality is not up to standard and the heat exchanger and pipeline are damaged, all the consequences shall be borne by the user;

2. **Precautions for adding** antifreeze (it is strictly forbidden to use strong corrosive antifreeze such as methanol blending liquid).

1. When choosing antifreeze, pay attention to comparing the local lower temperature to ensure that the freezing point of the antifreeze is lower than the outdoor temperature;

2. In the process of adding, the amount should be appropriate. Antifreeze is mostly corrosive, and excessive use will affect the heat exchange performance of the unit, so in the case of meeting the antifreeze performance, the lower the concentration, the better.

3. Do not mix. Try to use the same brand of antifreeze, even if the main components of different models of antifreeze are the same, their additive formulas will be different, and they should not be mixed,

so as not to start chemical reactions, precipitation or bubbles.

4. Pay attention to the time of use. Generally speaking, the use time should not be too long, and need to be replaced regularly, it is recommended to change once a year, use pure water in summer, and change new antifreeze in winter

2.6 Waterway freeze protection

Icing can cause damage to the circulatory system. Since outdoor units may be exposed to sub-zero temperatures, care must be taken to prevent the system from freezing. All internal liquid circulation components are insulated to reduce heat loss. On-site piping must also have additional insulation.

In the event of a power failure, the freeze protection of the device itself fails. **Due to the possibility of power outages when unattended, suppliers recommend using antifreeze in water systems.**

Ensure that the concentration of ethylene glycol injected into the water system is shown in the table below, based on the minimum expected outdoor temperature. When glycol is added to the system, the performance of the unit will be affected. The correction factors for system unit capacity, flow, and pressure drop are listed in the table

Ethylene glycol concentration (%)	Correction factor				Freezing point "°C"
	Cooling capacity	Power input	Water resistance	stream	
0	1.000	1.000	1.000	1.000	0
10	0.984	0.998	1.118	1.019	-4
20	0.973	0.995	1.268	1.051	-9
30	0.965	0.992	1.482	1.092	-16

Table 2-14

Propylene glycol concentration (%)	Correction factor				Freezing point "°C"
	Cooling capacity	Power input	Water resistance	stream	
0	1.000	1.000	1.000	1.000	0
10	0.976	0.996	1.071	1.000	-3
20	0.961	0.992	1.189	1.016	-7
30	0.948	0.988	1.380	1.034	-13

Table 2-15

Uninhibited ethylene glycol becomes acidic under the influence of oxygen. The purity of copper and higher temperatures accelerates this process. Uninhibited acidity can attack metal surfaces, forming galvanic corrosion batteries that can cause serious damage to the system. This is extremely important:

1. Water treatment is performed correctly by qualified water experts.
2. Select ethylene glycol containing corrosion inhibitors to offset the acid formed by ethylene glycol oxidation.
3. **If a household hot water tank is installed, only propylene glycol is allowed.** In other devices, the use of ethylene glycol is also possible.
4. Do not use automotive ethylene glycol, because their corrosion inhibitors have a limited life and contain

silicates, which will pollute or block the system;

5. Galvanized pipeline is not used in ethylene glycol systems because it may cause precipitation of some elements in ethylene glycol corrosion inhibitors;

6. Ensure that ethylene glycol is suitable for the materials used in the system

Chapter III: Electrical Operations

3.1 Control:

3.1.1 Stop running

The shutdown occurs for the following reasons:

1. Abnormal shutdown: In order to protect the compressor, if an abnormal state occurs, the controller interface will display the system error code.

2. When the set temperature is reached, the system stops running.

3.1.2 DC Pump Control (PWM)

1. When the unit is turned on, the water pump P_a turned on; When the unit reaches temperature and stops, it is controlled as follows:

When the P_a pump runs 100% duty cycle full on for 2 minutes, enter the pump speed regulation, when the temperature difference > P99+3 or the water flow < P163, the output of the P_a pump is opened by 2%/40S, when the temperature difference is < P99-1 and the water flow >P163, the output of the P_a pump is reduced by 2%/40S:

(1) Factory parameter P28 = 0: When the water pump is stopped at the end of the temperature, the pump speed is reduced to 30%, and the water flow meter or water flow switch signal is not detected.

When there is a power on signal, the speed of the water pump rises to 99%, and the water flow or water flow switch is detected after 30 seconds.

(2) Plant parameter P28 = 1: When the temperature is stopped P_a the water pump stops after the compressor stops for 60s; Run 2 minutes every 10 minutes;

(3) Plant parameter P28 = 2: when the refrigeration reaches temperature P_a the water pump continues to run, and other modes run according to P28 = 1;

(4) Plant parameters P28 = 3: when the refrigeration and heating reach temperature P_a the water pump continues to run, and other modes run when P28 = 1;

(5) Plant parameters P28 = 4: when the floor heating reaches temperature P_a the water pump continues to run, and other modes run according to P28 = 1;

2. When the unit is turned off, the water pump stops after the compressor stops for 60s;

3. When the water flow switch of the unit is disconnected or the water flow is too low to protect E03, the P_a water pump stops;

4. During the defrosting process and antifreeze mode P_a the water pump is kept fully open;

3.1.3 Boot Control

Compressor starting conditions

After the press starts, it must meet the forced operation for 3 minutes (parameter P103) to allow the constant temperature shutdown/combination mode switching, and the compressor will not be turned off due to the change of inlet water temperature T8/hot water tank temperature T16 within 3min after starting.

1. Heating mode or floor heating mode

When [P116] = 0, press the inlet water temperature T8 to start and stop

The external environment temperature \geq heating start limit [P106] 30 °C, the unit is not allowed to start, otherwise it is judged according to the following:

Unit inlet water temperature $T8 < \text{Heating set temperature} - \text{Return difference value}$ 【P26】 or [P27], have the ability to demand, must start the unit;

When the parameter [P37] = 0, the inlet water temperature of the unit $T8 \geq$ the set temperature of heating, and the press is running continuously at the lowest frequency for ≥ 5 min, and the unit reaches temperature and stops;

When the parameter [P37] = 0, the inlet water temperature of the unit is $T8 \geq$ the heating setting temperature is +3, and the unit stops at temperature;

When the parameter [P37] = 1, the inlet water temperature of the unit is $T8 \geq$ the heating setting temperature is +0, and the unit reaches temperature and stops;

When [P116] = 1 according to the outlet water temperature T15 start and stop, the rest is the same as above.

Starting conditions: outlet temperature $T15 < \text{set temperature for heating} - \text{Return differential temperature} - \Delta TDT = \text{Difference before shutdown}$ (take absolute range: $1 \leq DT \leq 12$), and the outlet temperature $T15 < \text{set temperature for heating}$;

When P26 and P27 are set to 0, the differential temperature = $X/10$, X = inlet water temperature T8, range value $2 \leq \text{start-stop return difference} \leq 5$

For example: before shutdown, 35 °C inlet water temperature T8, return difference temperature = $35/10 = 3.5$ °C, the calculated value is rounded, and the actual return difference is calculated according to 3 °C

Before shutdown, 60 °C inlet water temperature T8, return difference temperature = $60/10 = 6$ °C, the actual start-stop return difference is calculated according to 5 °C (range value maximum 5 °C)

2. Hot water mode

(1) , external ambient temperature $T7 \geq$ hot water starting limit [P107] 50 °C, the unit is not allowed to start, otherwise according to the following judgment:

(2), hot water tank temperature $T16 \text{Set the temperature} < \text{hot water} - \text{Return difference value}$ 【P96】, have the ability to demand, must start the unit;

(3) The temperature of the water tank of the unit is $T16 \geq$ the hot water setting temperature, and the unit

is stopped at the temperature;

3. Refrigeration mode^{xy}

1. The external ambient temperature $T7 \leq$ refrigeration starting limit [P105] 15 °C, the unit is not allowed to start, otherwise it is judged as follows:
2. The inlet water temperature of the unit $T8 >$ refrigeration setting temperature + return difference value [P26], the unit must be started;
3. When the parameter [P37] = 0, the inlet water temperature of the unit $T8 \leq$ the set temperature of refrigeration, and the press runs continuously at the lowest frequency for ≥ 5 min, and the unit stops at temperature;
4. When the parameter [P37] = 0, the inlet water temperature of the unit $T8 \leq$ the refrigeration setting temperature -3, and the unit stops at temperature;
5. When the parameter [P37] = 1, the inlet water temperature of the unit $T8 \leq$ the refrigeration setting temperature is -0, and the unit stops at temperature;

When [P116] = 1 starts and stops according to the outlet water temperature T15, the starting condition increases "outlet water temperature $T15 >$ refrigeration setting temperature + return difference temperature + ΔT ,

ΔT = difference before shutdown (take absolute value), and the outlet water temperature $T15 > 5^\circ\text{C}$ " is the same as other controls.

When P26 and P27 are set to 0, the return difference temperature = $5 - X/10$, X = inlet water temperature T8, the range value is $2 \leq$ the start-stop return difference ≤ 5

3. 1. 3.2 Compressor shutdown conditions

1. The outdoor unit has a shutdown failure;
2. The outdoor unit receives the shutdown command;
3. Forced shutdown instruction when the unit is changed to mode;
4. The unit has no capacity to demand, and the temperature is stopped.

If any of the above conditions are met, the compressor operation is stopped.

3.1.3.3 Compressor operating frequency control

1. The compressor starts to 45HZ for 3 minutes of operation, and then switches to the automatic control frequency.

2. Compressor frequency reduction or normal shutdown control: the compressor frequency is reduced to 30Hz in a cycle of 1HZ/1 second, and then stop running.

3. After compressing and turning off the machine, it must be delayed for at least 3min to open, and there is no 3min delay in the first power on;

3.1.3.4 Compressor temperature shutdown control mode

1. Heating mold type

6.3.4.1 、 When the parameter [P37] = 0, the outlet water temperature T15 or the inlet water temperature T8 \geq the heating setting temperature, and the press is running continuously at the lowest frequency for ≥ 5 min, the outlet or inlet water temperature \geq the heating setting temperature +3, and the unit is stopped;

6.3.4.2 、 When the parameter [P37] = 1, the outlet water temperature T15 or the inlet water temperature T8 \geq the heating setting temperature, and the unit is stopped;

6.3.4.3 、 When the parameter [P37] = 2, the refrigeration is controlled according to the parameter [P37] = 0, and the floor heating is controlled according to the parameter [P37] = 1;

2. Hot water mode

When the hot water tank temperature T16 \geq hot water set the temperature, the unit stops, and there is no constant temperature mode.

3. Refrigeration mode

6.3.6.1、 When the parameter [P37] = 0, the outlet water temperature T15 or the inlet water temperature T8 \leq the refrigeration set temperature, and the press is running continuously at the lowest frequency for ≥ 5 min, the outlet or inlet water temperature \leq the refrigeration setting temperature +3, and the unit is stopped;

6.3.6.2、 When the parameter [P37] = 1, the outlet water temperature T15 or the inlet water temperature T8 \leq the refrigeration setting temperature, and the unit is stopped;

6.3.6.3、 When the parameter [P37] = 2, the refrigeration is controlled according to the parameter [P37] = 0, and the floor heating is controlled according to the parameter [P37] = 1

Note: When the parameter P116=1, the unit is controlled according to the outlet water temperature T15, and when the parameter P116=1, the incoming group is controlled according to the inlet water temperature T8.

3.1.4 High temperature sterilization

(Parameter P140=0 is effective when electric heating of hot water is enabled).

Only effective in hot water mode, sterilization function selection: [L12] = 0, automatic; [L12] = 1, disabled; [L12] = 2, manual.

1. When selecting Automatic Control, it will automatically judge to enter according to the following conditions:

- (1) The number of sterilization interval days [L13], default: 7 days, the unit is first powered on and calculated;
- (2) Sterilization start time [L14], default: 23:00;
- (3) Sterilization running time [L15], default: 10min;
- (4) Sterilization temperature setting [L16], default: 70°C.

- (5) The unit is in air conditioning mode, shutdown or standby, all transferred to hot water mode, according to the temperature of the water tank, determine the compressor and hot water electric heating switch;
- (6) When hot water tank temperature $T16 < 50\text{ }^{\circ}\text{C}$, the compressor is turned on, and the hot water electric heating is turned on;
- (7) When the temperature of the hot water tank is $T16 \geq 50\text{ }^{\circ}\text{C}$, the compressor is turned off, and the compressor turns into normal operation after it is turned off, if it is the heating mode before entering the antivirus, it will reverse the heating mode, and the temperature of the water tank will continue to work by the electric heating of the water tank;
- (8) When the temperature of the hot water tank $\geq [L16]$, the hot water electric heating is turned off, and the time is recorded, and when the time $\geq [L15]$, exit the sterilization mode.
- (9) When the continuous operation time of the antivirus exceeds three hours, exit the sterilization mode.

2. [L12] = 2, when manually controlled, press and hold the switch + timing + down button at the same time to enter.

3.1.5 Silent Mode 🌙

It operates according to the maximum frequency limit of silent compressor [P88] 50 Hz and the maximum frequency limit of static fan [P89] 40Hz.

Note: Fan speed = [P89] * 15

3.1.6 Waterway emptying mode/forced opening of the pump

In the shutdown state, long press "on/off" + " Δ " + " ∇ " for 5s to enter; Press or press the "On/Off" key again or directly to exit;

LCD display: The water pump icon flashes

Note: DC water pump 100% output

3.1.7 Mandatory defrosting ❄️

In heating, underfloor heating or hot water mode and External disk Tube temperature $T1 < \text{exit Defrost coil temperature (parameter P36)}$, long press the "M" + " ∇ " button for 5 seconds, then force into defrosting.

3.1.8 Linkage control

1. When $P05=1$, disable the linkage switch DI6, and the unit will be normally controlled to start and stop according to the wire controller
2. When $P05=0$, if the linkage switch DI6 is in the disconnected state, the unit is not allowed to start up; If the linkage switch DI6 is closed, start and stop according to the water temperature;
3. When $P05=2$, if the linkage switch DI6 is in the open state, the unit is on standby, and the three-way valve and water pump are controlled by constant temperature shutdown;

If the linkage switch DI6 is closed, the machine starts and stops according to the water temperature;

4. When P05=3, the linkage switch DI6 is only valid in heating, floor heating and cooling mode, and is invalid in hot water mode

Note: The heat pump linkage switch is a dry contact signal, which indicates two states on the electrical switch, including closed and disconnected, and there is no polarity between the two contacts of the dry contact and can be interchanged.

3.1.9 Refrigerant recovery function

In the shutdown state or refrigeration mode, long press "on/off" + "△" for 5s to enter; Press the "On/Off" key to exit.

LCD display: the refrigeration icon flashes, and the temperature zone displays the low pressure temperature value.

3.1.10 Expiration Password Settings

In the unlocked state, press and hold 5 buttons at the same time 5S until "beep" to enter the use period password input, at this time the temperature zone displays the password "0000", you can press the "△" or "▽" key to enter the password, and then press "M" to switch to the next password input, enter the 4-digit password press the "M" key to confirm, the password is correct to enter the term setting, at this time the clock area shows the previous setting value, the default is "0 days", the range is 0-360 days, press the "△" or "▽" key to adjust, and then press "M" to confirm, Return to the main interface, press and immediately release the " " key or there is no key operation within 60 seconds will automatically return to the normal display state, do not save the set value, the factory password default 8563. When the operating time of the unit meets the expiration date, the remote controller displays E11, and if the restriction needs to be removed, the expiration time is set to "0" days

3.1.11 Control EH1/gas control signal output for electric heating of hot water

When parameter P140=0 enables electric heating of hot water EH1

1. After the unit enters the hot water secondary antifreeze, turn on the hot water electric heating EH1
2. When the unit is not freeze-proof, when the machine is turned off or turned on in cold and non-hot water mode, the hot water electric heating EH1 stops;
3. Unit non-downtime fault protection:
 1. Hot water electric heating EH1 starting conditions: When the following conditions are met at the same time, start hot water electric heating EH1
 1. Outdoor ambient temperature $T7 \leq$ hot water electric heating set ambient temperature (parameter P22, default -7), outdoor ambient temperature T7 sensor failure, this item is invalid;
 2. Hot water tank temperature $T16 <$ Set temperature-return difference value (parameter P96).
 3. Hot water electric heating EH1 stop conditions: If any of the following conditions are met, stop hot

water electric heating EH1

1. When the outdoor ambient temperature $T7 \geq$ set ambient temperature $+3^{\circ}\text{C}$ for electric heating of hot water, this item is invalid when the outdoor ambient temperature T7 sensor fails;
2. Hot water tank temperature $T16 \geq$ Set temperature.

When the parameter P139=2 and P140=2 are enabled for gas control, the hot water electric heating signal becomes a gas control signal output (program version above 3.6.7 is valid)

1. Heating/underfloor heating mode:

(1) When the ambient temperature $\leq P21$, prohibit the heat pump from starting, and turn on the gas water heater;

Buffer tank temperature $T10 <$ heating heat source setting temperature-temperature control difference (P26/P27), gas control signal output 220V

Buffer water tank temperature $T10 \geq$ heating heat source setting temperature, gas control signal output 0V;

(2) When the ambient temperature of $P21 < P22$, the heat pump can be turned on;

Buffer water tank temperature $T10 <$ heating heat source combined temperature upper limit P110, heat pump allows to open the machine heat, according to the inlet water temperature T8/Effluent temperature T15 Normal control

Buffer tank temperature $T10 \geq$ heating heat source combined temperature upper limit P110, heat pump stop heating, if buffer tank temperature $T10 <$ heatingSet the temperature, Turn on the gas control signal output 220V and continue heating to the set temperature

Buffer tank temperature $T10 \geq$ heating setting temperature, gas control signal output 0V;

When the ambient temperature $\geq P22$, open the heat pump for heating, and control it normally according to the inlet and outlet water temperature T8 / outlet water temperature T15, and prohibit gas heating;

2. In hot water mode, heat pump heating is prohibited, only gas heating is allowed:

Hot water tank temperature $T16 <$ hot water setting temperature - hot water control difference, gas control signal output 220V

Hot water tank temperature $T16 \geq$ hot water setting temperature, gas control signal output 0V;

Hot water + floor heating, hot water + heating mode, heating according to the above 1, hot water according to the above 2 operation

Additional Notes:

1. When the ambient temperature fails, P22 is \leq according to the ambient temperature.
2. There is no demand for hot water by default in single (heating/floor heating) mode
3. When online control, the slave follows the buffer water tank temperature T10 of the host
4. When the gas control signal is output and the heat pump is not started, the host water pump needs

to be turned off, and only if the antifreeze conditions are met, it will be turned on

5. When the unit enters the secondary antifreeze, the gas water heater is started, and the heat pump is started at the same time.

6. Start the gas water heater when the frost is defrosted.

7. When P26 and P27 are set to 0, the fixed return difference is set to 5 °C

3.1.12 Heating auxiliary electric heating EH2

The effective parameters of floor heating and heating mode P139=0 is enabled, P139=1 is invalid, and P139=2 gas control is invalid

1. If the water pump stops in any state, the electric heating stops immediately;
2. After the unit enters the antifreeze protection on the heating side, the heating auxiliary electric heating EH2 is turned on after the water pump is started for 10s;
3. In the non-antifreeze state of the unit, when the machine is turned off or turned on to cool, the heating auxiliary electric heating EH2 stops;
4. In the hot or floor heating mode of the unit, control as follows:
 1. Unit non-downtime fault protection:
 1. Heating auxiliary electric heating EH2 starting conditions: When the following conditions are met at the same time, start heating auxiliary electric heating EH2
 1. Outdoor ambient temperature $T7 \leq$ electric heating set ambient temperature (parameter P22, default -7), when the external ambient temperature T7 sensor fails, this item is invalid;
 2. Inlet water temperature $T8 <$ set temperature-return difference value (parameter P26);
 3. Heating auxiliary electric heating EH2 stop conditions: If any of the following conditions are met, stop heating auxiliary electric heating EH2
 1. When the outdoor ambient temperature $T7 \geq$ set ambient temperature +3°C for electric heating, this item is invalid when the outdoor ambient temperature T7 sensor fails;
 2. Inlet water temperature $T8 \geq$ set temperature.
 3. The unit has shutdown fault protection:
 1. Heating auxiliary electric heating EH2 starting conditions: When the following conditions are met at the same time, electric heating is started
 1. The inlet water temperature T8 sensor is normal;
 2. Inlet water temperature $T8 <$ set temperature-return difference value [P26].
 - 2) Heating auxiliary electric heating EH2 stop conditions: If any of the following conditions are met, stop heating auxiliary electric heating EH2
 1. failure of the inlet water temperature T8 sensor;
 2. Inlet water temperature $T8 \geq$ set temperature.
3. When defrosting the outdoor unit: turn on the heating auxiliary electric heating EH2 during the defrosting process, and continue to judge according to the above conditions after exiting the defrosting.

Note: When the temperature control mode of the unit P116=0, it is controlled according to the inlet water temperature T8

When the temperature control mode of the unit P116=1, it is controlled according to the outlet water

temperature T15

3.1.13 Unit auxiliary pump P_c

P161 auxiliary pump selection type: 0: hot water / 1: air conditioning / 2: floor heating / 3: air conditioning floor heating / 4: all, default is 0

When the corresponding mode is running, when the main engine circulating pump is P_a started, the auxiliary pump of the unit P_c started at the same time

3.1.14 Hot water three-way valve SV1

1. Hot water mode: three-way valve SV1 is always turned on.
2. Non-hot water mode: three-way valve SV1 is normally closed and energized.

3.1.15 Air conditioning three-way valve SV2

1. In heating or cooling mode: the three-way valve SV2 is normally open and electrified.
2. In floor heating mode: the three-way valve SV2 is normally closed and electrified.
3. Antifreeze enters antifreeze according to the outlet water temperature T15 or hot water tank temperature T16, and open the three-way valve in the corresponding mode.
4. Defrost according to the current mode and open the three-way valve in the corresponding mode.

3.1.16 Air conditioning secondary water pump P_b (secondary system).

1. When P150=1 is selected: start operation when the unit has a boot signal or reaches temperature standby;
2. When P150=2 is selected: the air conditioning pump runs in tandem
 1. When the terminal equipment has heating or cooling needs, the feedback opening signal is fed back and the P_b water pump is turned on;
 2. When the terminal equipment has no heating or cooling demand, the feedback is off the signal and the water pump is turned off P_b.
3. When P150=3 is selected: control as follows, DC water pump and AC water pump use this logic, do not do signal feedback alarm
 1. When the main mechanism is hot:
 1. Indoor temperature < indoor set temperature -2 °C, P_b the water pump starts, running at speed [P100];
 2. Indoor temperature < indoor set temperature -1°C, P_b pump speed +2%/40sec, maximum output 100%;
 3. Indoor temperature > indoor set temperature +2°C, P_b pump turned off;
 4. Indoor setting temperature +2°C ≥ indoor temperature ≥ indoor setting temperature +1°C, P_b pump speed -2%/40sec, minimum output ≥ [P100];
 5. Indoor setting temperature -1°C < indoor temperature < indoor setting temperature +1°C, P_b

pump speed does not change.

6. When the main engine is cooled:
 1. Indoor temperature > indoor set temperature +2°C, P_b water pump starts, running at speed [P100].
 2. Indoor temperature > indoor set temperature +1°C, P_b pump speed +2%/40sec, maximum output 100%.
 3. The indoor temperature < the indoor set temperature -2 °C, and the P_b pump is turned off
 4. Indoor setting temperature -1°C ≥ indoor temperature ≥ indoor setting temperature -2°C, P_b pump speed -2%/40sec, minimum output ≥ [P100].
 5. Indoor setting temperature -1°C < indoor temperature < indoor setting temperature +1°C, P_b pump speed does not change.

Note: The wire controller has a built-in indoor temperature NTC sensor

1. The speed regulation of the water pump is optional, if the speed of the pump is not required, the water pump can be directly connected to the secondary pump relay.

3.1.17 Heat source hot water pump P_e

Opening conditions:

1. When the hot water side heat source temperature T12 > hot water tank temperature T16 + hot water heat source return difference P151 (default 7 °C, set to 0, shield (1) and (2) conditions),
2. When the heat source temperature T12 on the hot water side < set the temperature of the hot water
3. When the heat source linkage switch DI6 is closed

At the same time, if the above conditions are met, the heat source water pump is turned on.

Closing conditions:

1. When the hot water side heat source temperature T12 ≤ hot water tank temperature T16 - hot water heat source return difference P151 is detected (**set to 3, shield (1) and (2) conditions**),
2. When the hot water tank temperature T16 is detected ≥ the hot water side heat source setting temperature,
3. When the hot water side heat source linkage switch DI6 is disconnected;

If any of the above conditions are met, the heat source pump on the hot water side P_e turned off.

Note: When the hot water side heat source linkage switch DI6 is closed, enter the hot water side heat source joint mode (this mode is not reflected in the display), set the temperature to 70 °C by default, when the linkage is disconnected, set the temperature of the hot water side tank before the temperature is restored.

3.1.18 Heat source heating water pump P_f

Opening conditions:

1. When the heating side heat source temperature T11 > heating buffer tank temperature T10 + heat source return difference P152 is detected (when the default 7°C is set to 0, shield (1) and (2) conditions),
2. When the hot water tank temperature T16 is detected < heating set temperature

3. When the heating side heat source linkage switch DI6 is closed

At the same time, if the above conditions are met, the heat source water pump is turned on.

Closing conditions:

1. When the heating side heat source temperature $T_{11} \leq$ heating buffer tank temperature T_{10} -heat source return difference P_{152} is detected (when set to 3, shielding (1) and (2) conditions),
2. When the heating buffer tank temperature T_{10} is detected \geq heating set temperature,
3. When the hot water side heat source linkage switch DI6 is disconnected;

If any of the above conditions are met, the heat source pump on the hot water side is turned off.

Note: When the heating side heat source linkage switch DI6 is closed, enter the heating side heat source joint mode (this mode is not reflected in the display), set the temperature by default 60 °C, when the linkage is disconnected, set the temperature to restore the heating side water tank set temperature.

Winter frost protection

In order to prevent the circulating water of the unit from freezing in winter, the unit adds antifreeze protection control.

Freeze protection enters the exit condition

1. The unit is in the shutdown or start-up fault shutdown state

1. First-class antifreeze protection entry, exit

1. When the outdoor ambient temperature $T_7 \leq 5^\circ\text{C}$ [P117], enter the **first-level antifreeze protection**, the main engine circulating water pump P_a turn on every 10min for 2min (parameter P29, default 2min), and each waterway runs for 2min;
2. When the outdoor ambient temperature $T_7 \geq$ [P117] +3 °C, exit **the first-level antifreeze protection**;

3. Secondary antifreeze protection entry, exit

1. When the outdoor ambient temperature $T_7 \leq 5^\circ\text{C}$ [P117] and the outlet temperature $T_{15} \leq 3^\circ\text{C}$ [P118] lasts for 10s, the secondary antifreeze protection is entered, the hot water three-way valve is closed, the heating three-way valve is opened, the main engine circulating water pump is P_a open, the unit is forced to start heating operation, when the unit has an unprotected shutdown failure, after the pump is P_a running for 10s, the auxiliary electric heating is forcibly turned on.
2. When the outdoor ambient temperature $T_7 \geq$ [P117] +3 °C or the outlet water temperature $T_{15} \geq 15^\circ\text{C}$, exit **the secondary antifreeze protection**.

(1) and (2) above judge that when the outdoor ambient temperature T_7 sensor fails, ignore this temperature condition; When the outlet water temperature T_{15} sensor fails, it is replaced by the inlet water temperature T_8 ;

2. The hot water function timing group is in the shutdown or start-up fault shutdown state:

1. When the outdoor ambient temperature $T7 \leq 5^{\circ}\text{C}$ [P117] and the hot water tank temperature $T16 \leq 3$ [P118] lasts for 10s, enter the secondary antifreeze protection, the hot water three-way valve SV1 opens, the heating three-way valve SV2 does not operate, the main engine circulating water pump is P_a turned on, the unit is forced to start heating operation, when the unit has an unprotected shutdown failure, after the pump is P_a running for 10s, the hot water electric heating EH1 is forcibly turned on;
2. When the outdoor ambient temperature $T7 \geq$ [P117] $+3^{\circ}\text{C}$ or the hot water tank temperature $T16 \geq$ [P118] $+12^{\circ}\text{C}$, exit the secondary antifreeze protection.

Terminal display during freeze protection

After the unit enters the antifreeze protection, the wire controller displays the "antifreeze" or "water pump P_a" icon on/flashes, which is not a unit failure;

Hot water line freeze protection

When P48=1 enables the hot water function and the antifreeze interval of the P162 hot water pipeline is not set to 0, enter the hot water pipeline to prevent freezing

When the outdoor ambient temperature is $T7 \leq 2^{\circ}\text{C}$ and the interval time is $> P162$, enter the hot water pipeline to prevent freezing;

When the outdoor ambient temperature is $T7 \geq 4^{\circ}\text{C}$, exit the hot water pipeline to prevent freezing;

Enter hot water to prevent freezing, hot water three-way valve SV1 turn on the water pump P_a cycle for 2 minutes and then turn back to normal control, if there is a need for hot water at this time, then run the hot water mode.

When there is no need for hot water pipeline freeze protection, the parameter P62=0 or P48=0 needs to be disabled.

3.1.19 Host water flow switch protection

When P101=0, that is, when the AC pump is selected, it is detected as follows

1. After the main engine water pump P_a started to run for 40s, if the water flow switch is in the disconnected state for 5 consecutive seconds, the water flow switch protection will be entered, the compressor and water pump will stop running immediately, and the fault code "E03" will be displayed on the screen of the online controller;
2. When the water pump P_a detects that the water flow switch is closed for 10S continuously before starting, and judges that the water flow switch is in a failed state, it enters the water flow switch protection and reports E03 failure; When the water flow switch failure detection P44 is disabled, the water pump P_a does not fail to detect before starting.
3. After the water pump is shut down P_a for 1 minute, the water retreat flow switch is protected and the P_a pump is restarted;
4. If this protection occurs 3 times in a row within 60 minutes, the protection cannot be restored, and it

must be powered off or turned off and then turned on or closed by water flow can be eliminated.

When P101=1, that is, when the DC variable frequency pump is selected, it is detected in the following way

The water flow switch is not detected in heating and floor heating modes

Before the compressor starts:

The circulating water pump P_a detects the water flow switch and water flow after running for 30 seconds at 100% output capacity, if the water flow switch is disconnected or the water flow \leq P134 water flow is too low protection value, the pump stops running; After 5S, restart the P_a water pump into the second water flow switch and water flow detection; If the water flow switch is detected three times in a row or the water flow \leq P134, the water flow fault is reported, "E03" is displayed, and the P_a pump is not restarted locked fault

In the above water flow switch and water flow detection process, if the water flow is closed and the feedback water flow $>$ P134 water flow is too low protection value, the water flow of the unit is judged to be normal, the start-up process is entered, and the fan and compressor are started successively to resume normal operation

After the compressor starts:

If the water flow switch is disconnected for 5 seconds or the water flow \leq P134 water flow is too low and the protection value lasts for 5S, the water flow fault is reported, the unit is stopped, the fault code E03 is displayed, and the water flow detection before the press is started after the pump stops for 30S seconds.

Note 1: After the water flow fault is locked, as long as the unit is re-powered or turned off and turned on again, or the water flow is detected to be closed or the water flow rate is too low \geq P134 water flow protection value, the water flow fault will be automatically released and normal operation will be resumed.

Note 2: When P03=1 does not detect the water flow switch, when P134=0 does not detect the water flow is too low

Note 4: If the unit meets the antifreeze conditions, it is given priority to enter the antifreeze control, and the shielded water flow switch is detected at this time.

Note 5: When P03=0, when the water flow switch is enabled,

1. The water flow switch protection during the operation of the shielded unit in hot water, floor heating and heating mode, but the water flow switch detection before the compressor is started is still valid;
2. In refrigeration and defrost mode, the water flow is too low frequency limiting protection and water flow switch protection are effective.

When P03=1, the water flow switch protection is completely shielded, including the water flow switch failure detection.

3.1.20 Protection of excessive temperature difference between inlet and outlet pipes

1. After the compressor starts to run for 3 minutes, the outlet water temperature T15-inlet water temperature T8 is detected for 10 seconds in non-hot water mode \geq temperature difference protection value (parameter P23) or inlet water temperature T8-outlet water temperature T15 \geq Temperature difference protection value (**parameter P23**), that is, the temperature difference into the inlet and outlet water

temperature is too large protection, the unit immediately stops, and on the screen of the wire controller Failure code "E37" is displayed.

2. After the unit protection is shut down for 3min, exit the temperature difference between the inlet and outlet pipes is too large to protect.

3.1.21 High voltage protection

1. In refrigeration mode, after the compressor starts operation, the high-pressure saturation temperature ≥ 64 °C (parameter P11) for 5 consecutive seconds, the compressor immediately stops and the fault code "E51/E53" is displayed on the screen of the controller;
2. After the unit protection is stopped for 1min, when the high-pressure saturation temperature ≤ 50 °C, the protection is withdrawn;
 1. If this protection occurs three times in a row within 60 minutes, the protection cannot be recovered and must be powered off to be eliminated.

3.1.22 Low voltage too low protection

1. In heating mode, after the compressor starts operation for 5 minutes, when the low-pressure and high-pressure saturation temperature ≤ -40 °C (parameter P13) for 5 consecutive seconds, the compressor immediately stops running, and the fault code "E52/E54" is displayed on the screen of the controller;
2. Shield low voltage too low protection detection in any of the following situations:
The outdoor unit is in the defrosting process and within 3 minutes of exiting the defrosting;
Refrigerant recovery process;
The ambient temperature is ≤ -10 and the compressor is started for 3min.
3. After the unit protection is shut down for 1min, the low-pressure high-pressure saturation temperature ≥ -35 °C, the protection is withdrawn;
4. If this protection occurs three times in a row within 60 minutes, the protection cannot be recovered and must be powered off to be eliminated.

3.1.23 Protection from excessive exhaust temperature

1. After the compressor starts operation, when the compressor exhaust temperature $T_3 \geq 115$ °C (parameter P15) is continuously 5 seconds, the compressor will stop running immediately; and display the fault code "E12/E13" on the screen of the controller;
2. After the unit protection is shut down for 1min, the exhaust temperature protection of the compressor is withdrawn when the exhaust temperature ≤ 790 °C is withdrawn;
 1. If this protection occurs three times in a row within 60 minutes, the protection cannot be recovered and must be powered off to be eliminated

3.2 Display and operation of the remote controller:

3.2.1 Remote control interface display and operation

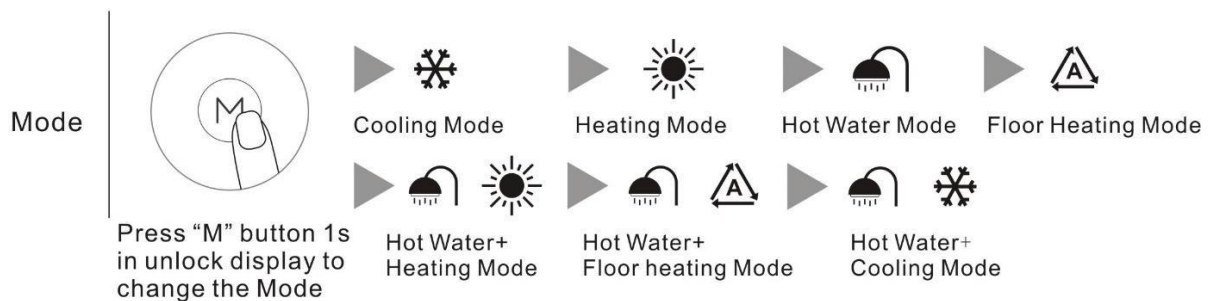
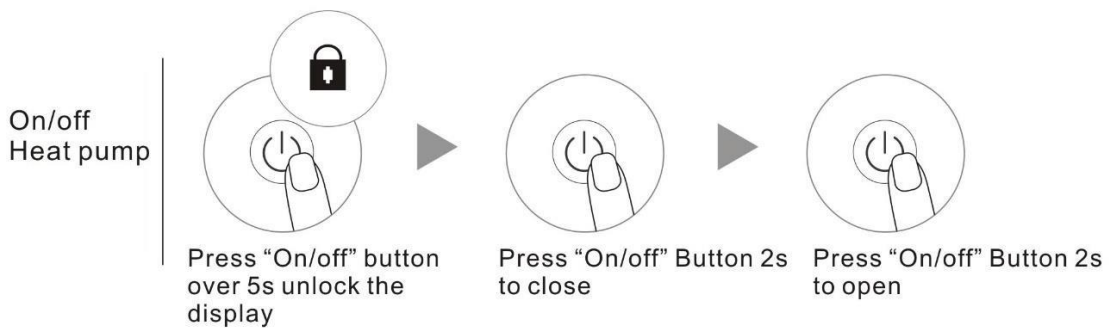
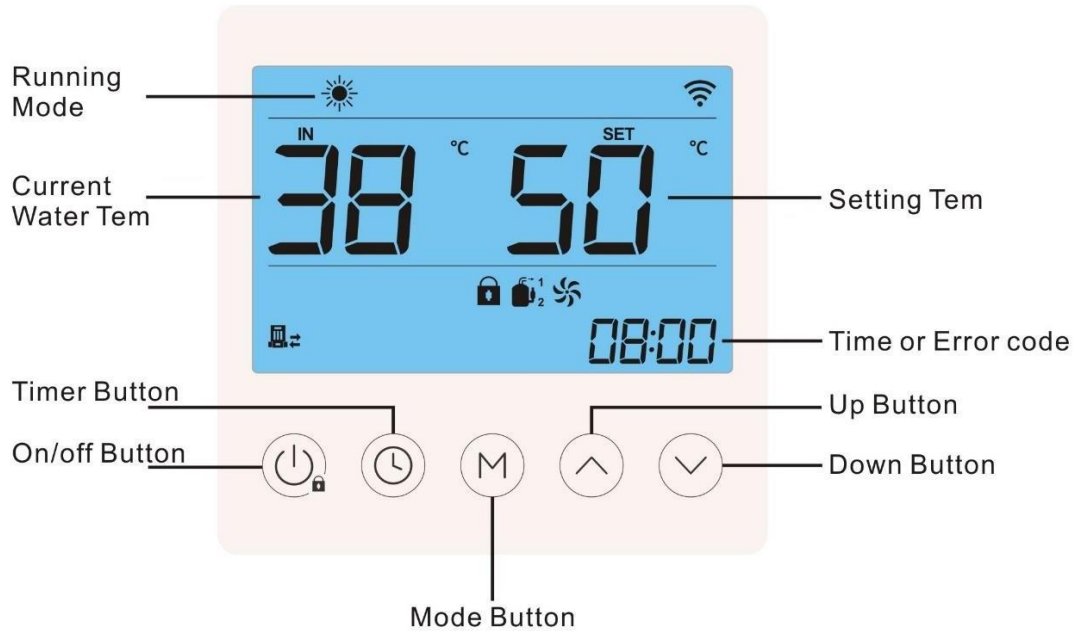

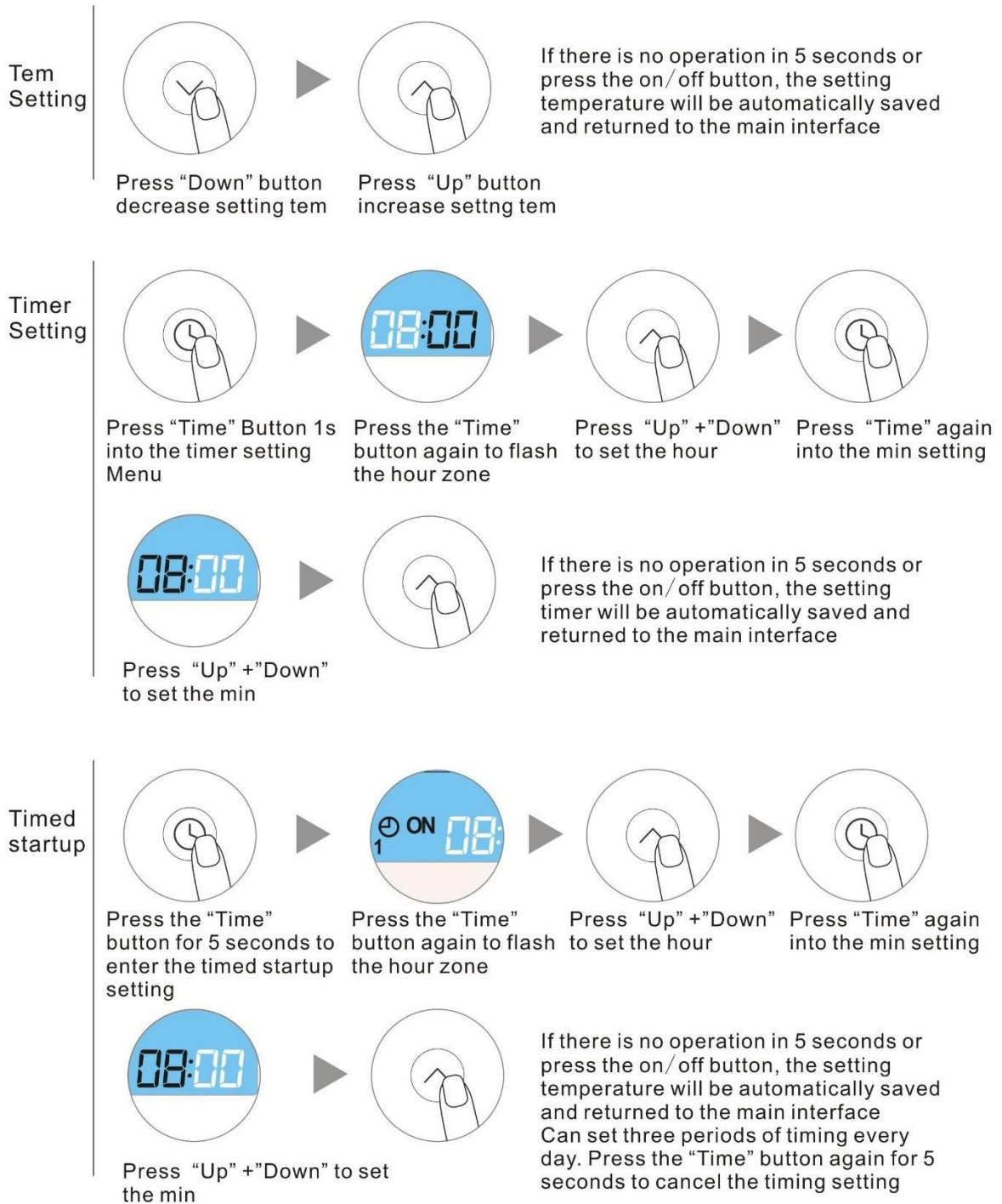

Weekly Timer Setting

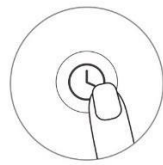

Press "Time" button 1s enter timer setting



Hour Zone Flashing

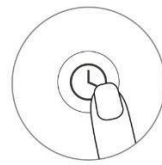

Press "Time" button 5s to start weekly timer setting

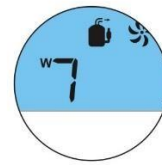

7 indicates that the time of day is Sunday W indicates that the weekly timing is enabled successfully

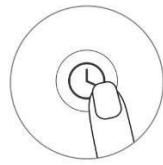

Press "Time" button 1s



Weekly timing zone flashes

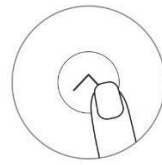

Press "Up" button can set the Monday

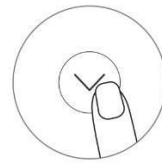

Press "Down" button can set the "Saturday"

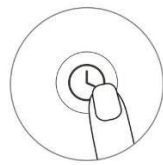

Press "Time" button 1s



The Hour zone flashes and use up and down buttons can set the current hour

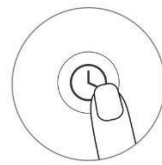

Press "Time" button 1s, The Min zone flashes and use up and down buttons can set the current min

Press the "Time" button for 5 seconds to cancel the weekly timing setting

Manual Electric heater

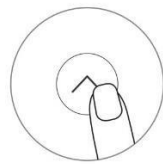
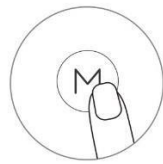

Press and hold the M key + Up key at the same time in the non-Cooling mode in the Unlock display to enter

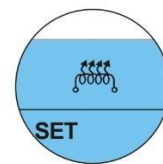

Electric Heater logo is on

Manual Defrost

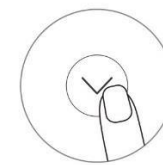
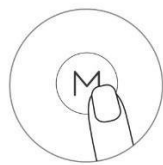

Press and hold the M key + Down key at the same time in the non-Cooling mode in the Unlock display to enter



Defrost logo is on

ECO Mode

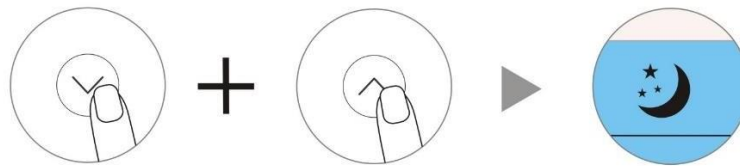

In the unlocked and power-on state, press and hold the up key + down key at the same time

ECO silent mode icon lights up

Water pump forced emptying mode

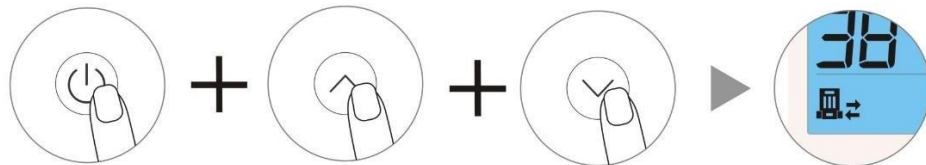

In the unlocked state, press and hold the ON/OFF key + up key at the same time to enter the forced emptying mode

The water pump icon flashes and enters the forced emptying mode

Configure Internet

Manual intelligent Internet configuration

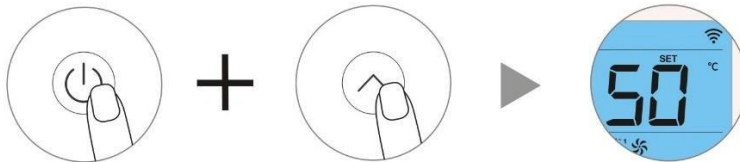

In the unlocked state, press and hold the ON/OFF key + up key at the same time to enter the smart Internet configuration mode

The WiFi icon flashes quickly, entering the distribution network state

Manual AP Internet configuration

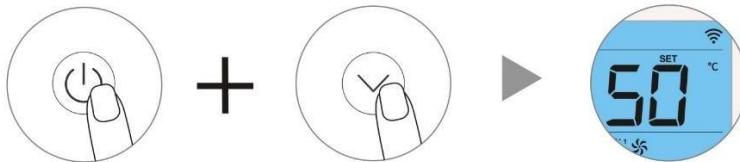

In the unlocked state, press and hold the ON/OFF key + down key at the same time to enter the AP Internet configuration mode

The WiFi icon flashes slowly, entering the Internet configuration state

APP Entrance



Scan the QR code to download "Tuya Smart"



Scan the QR code to download "Smart Life "

3.2.2 Setting and operation of climate compensation temperature curve

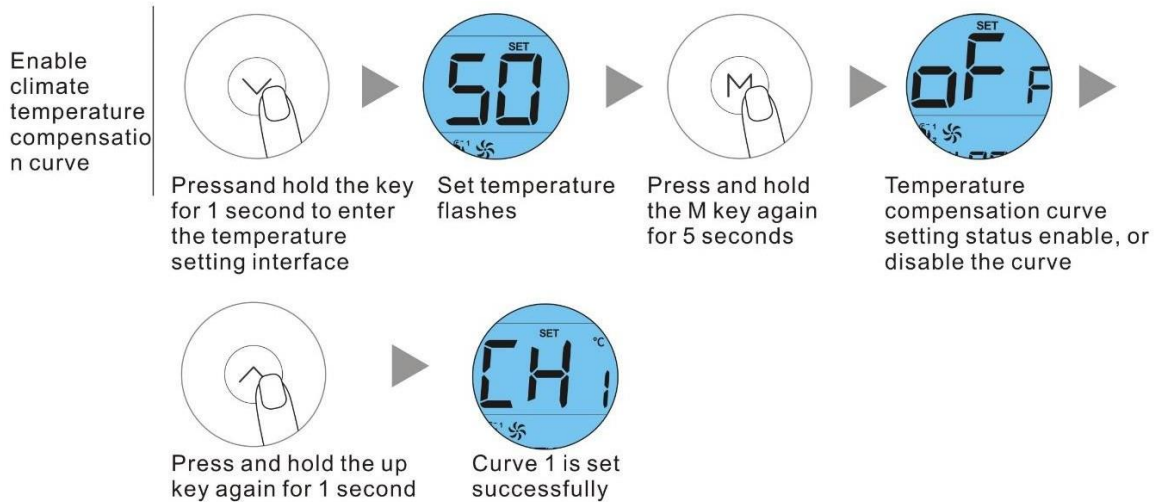

When the climate temperature compensation curve function is enabled, the user can select one of the eight curves in the main interface, the set temperature (T1s) is determined by the outdoor temperature (T4), and the relationship between the outdoor temperature and the set temperature (T1s) is as below

1. The target setting temperature will be automatically adjusted according to the corresponding setting curve
2. In the 4 charts below, curve 4 is the default curve, and curve 6 is the ECO energy-saving curve

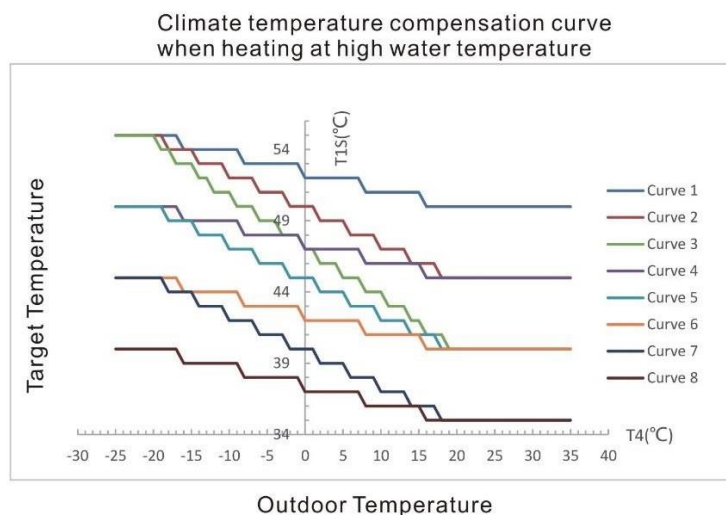

Climate temperature compensation curve when heating at low water temperature

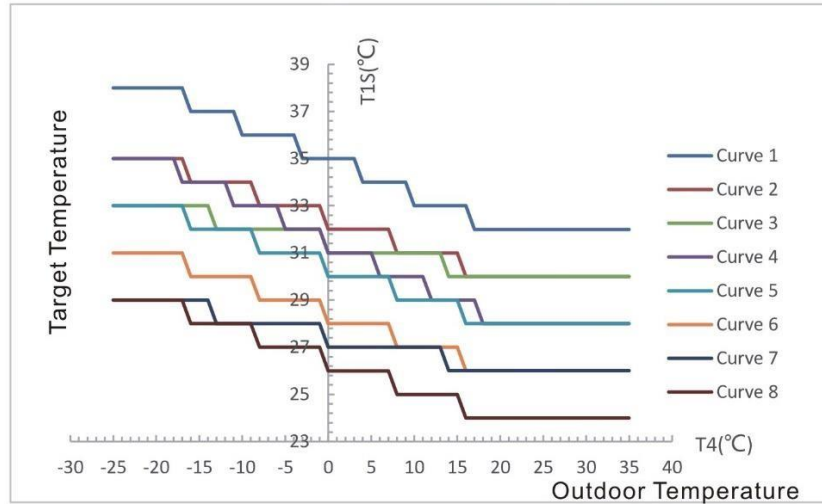

Climate temperature compensation curve when cooling at high water temperature

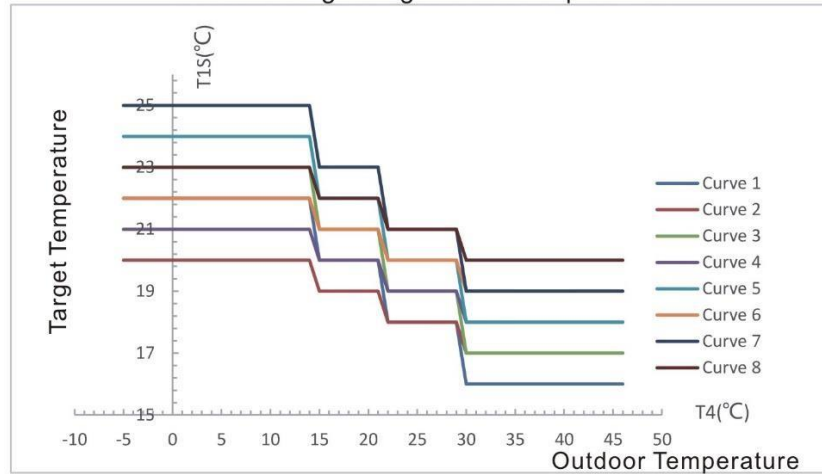

Climate temperature compensation curve when cooling at low water temperature

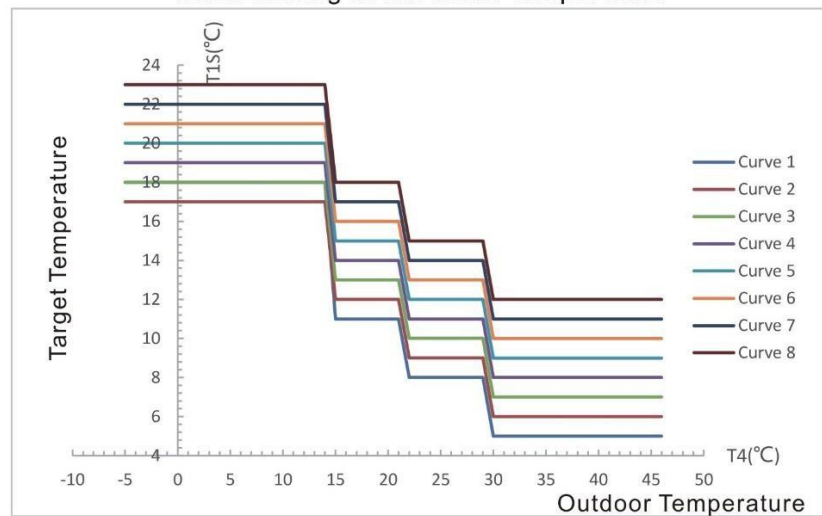

3.2.3 Setting and operation of unit tooling numbers

The correspondence table of model tooling numbers is as follows

Model tooling number comparison table					
Model	SOL-006HC1	SOL-010HC3	SOL-014HC3	SOL-018HC3	SOL-024HC3
Tooling number	109	110	111	112	114

Table 3-1

Each model has a unique model tooling number, the tooling determines the factory default parameters of the modified model, the tooling number is set incorrectly, the heat pump unit will not operate normally, so when the main control board PCB (AP1) needs to be replaced during the maintenance of the equipment, the correct tooling number needs to be set to allow the boot Here's how

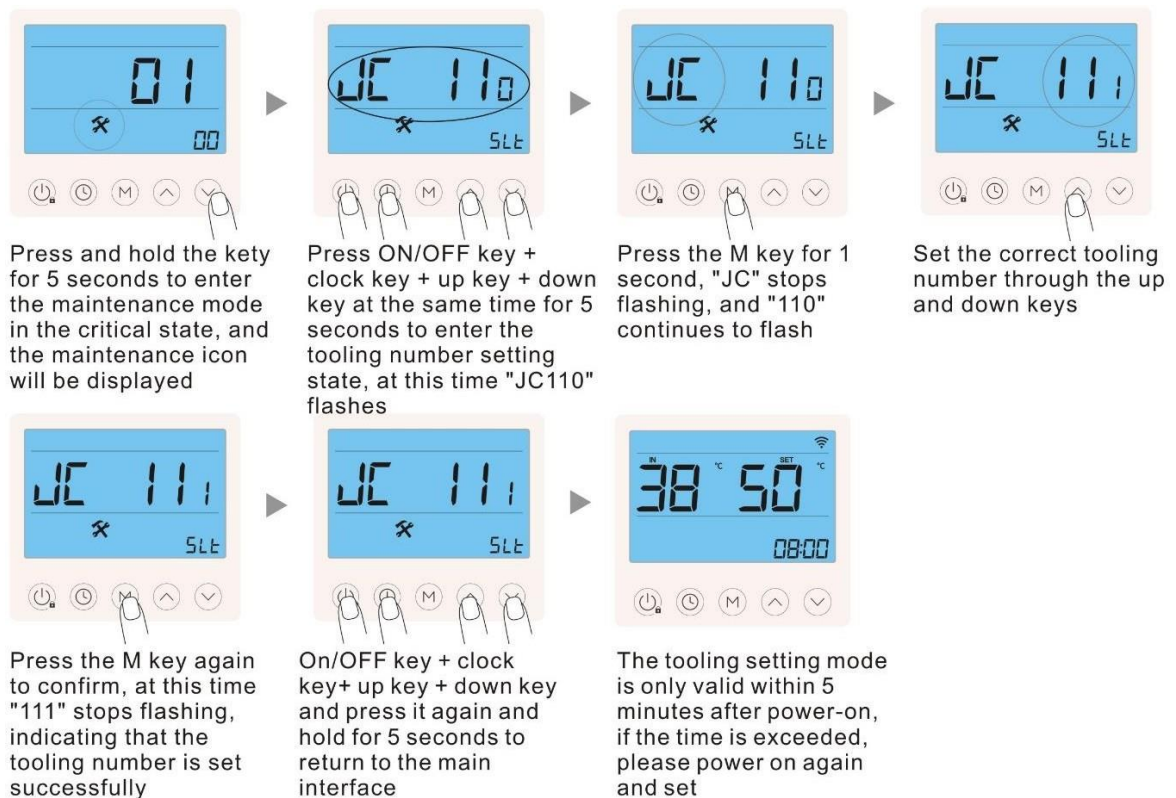

3.2.4 Wiring method and display of multiple unit networking

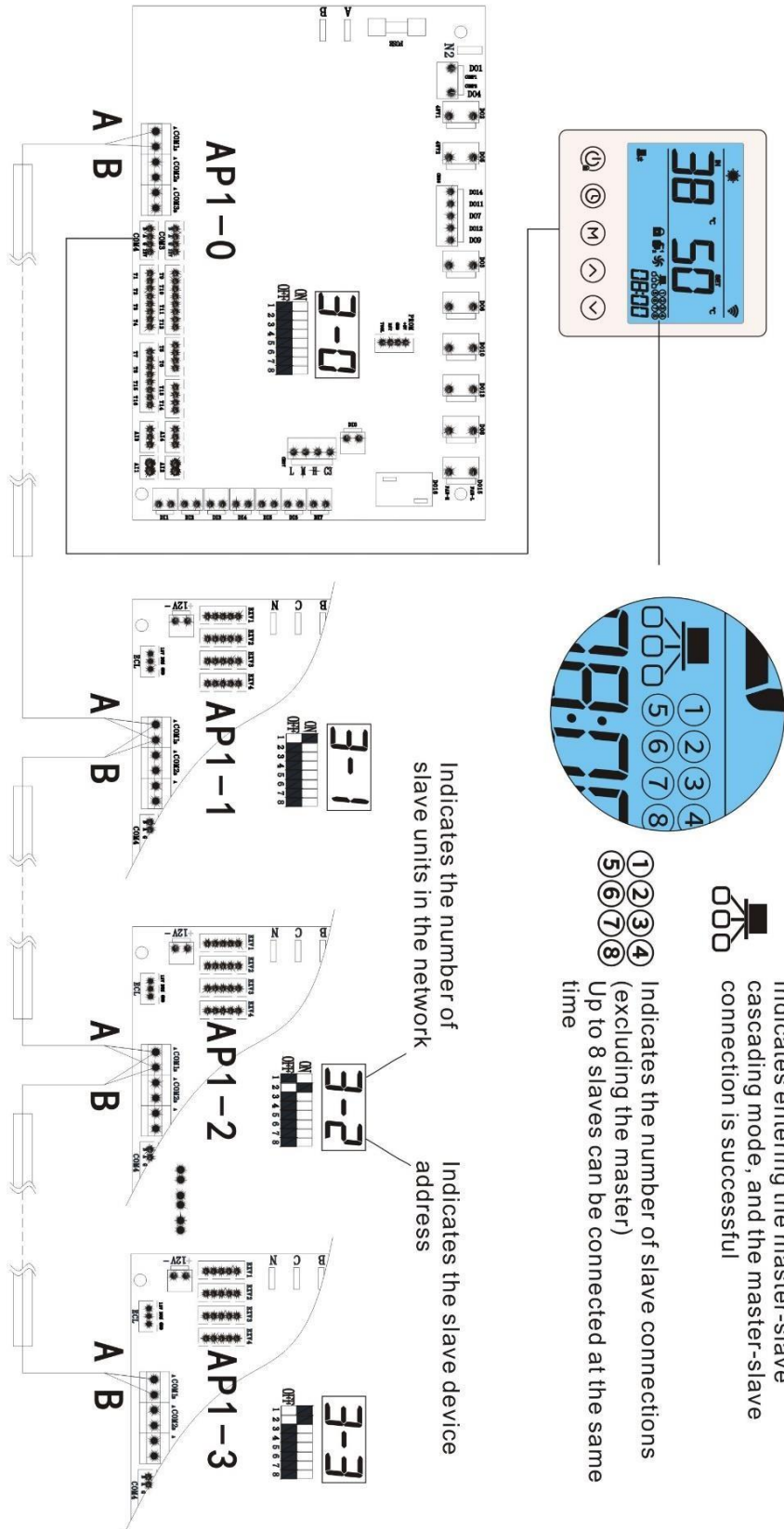

When modular control, be sure to check the device address before the unit is powered on, the host group number is "0", the 1# slave address is "1", the 2# slave address is "2", and so on, see the following table for details:

serial number	SE1	SE2	SE3	SE4	meaning	remark
1	OFF	OFF	OFF	OFF	host	
2	ON	OFF	OFF	OFF	Slave 1	
3	OFF	ON	OFF	OFF	Slave 2	
4	ON	ON	OFF	OFF	Slave 3	
5	OFF	OFF	ON	OFF	Slave 4	
6	ON	OFF	ON	OFF	Slave 5	
7	OFF	ON	ON	OFF	Slave 6	
8	ON	ON	ON	OFF	Slave 7	
9	OFF	OFF	OFF	ON	Slave 8	

Table 3-2

3.2.5 Operation method of unit status parameter query

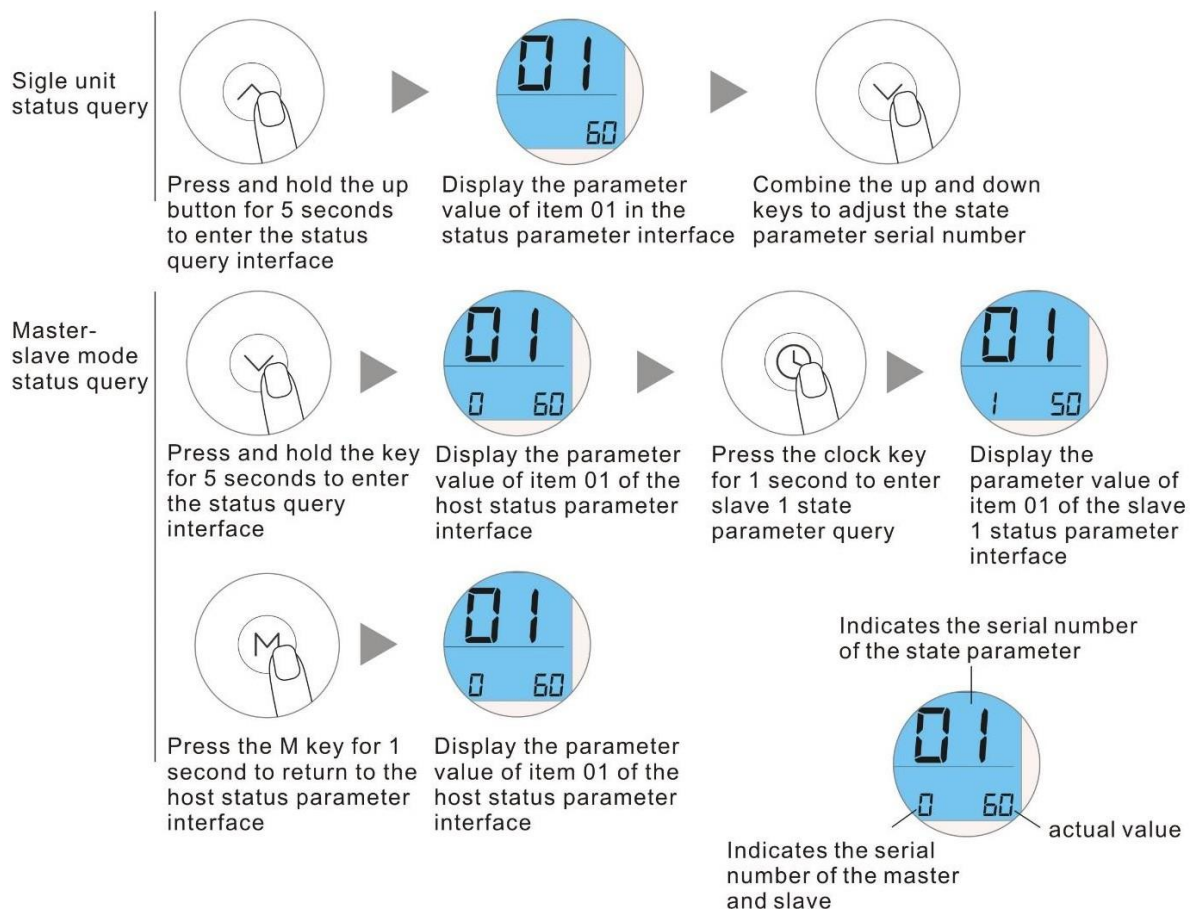

Status parameter table

code	Represents meaning	Display range	Query code	Represents meaning	Display range
1	Compressor operating frequency	0~150Hz	31	obligate	
2	Fan operating frequency/speed	0~999Hz	32	obligate	
3	Number of steps of electronic expansion valves	0~480P	33	obligate	
4	EVI valve steps	0~480P	34	obligate	
5	AC input voltage	0~500V	35	obligate	
6	AC input current	0~50.0A	36	obligate	
7	Compressor phase current	0~50.0A	37	obligate	
8	Compressor IPM temperature	-40~140°C	38	obligate	
9	High pressure saturation temperature A14	-50~200°C	39	obligate	
10	Low pressure saturation temperature A13	-50~200°C	40	obligate	
11	External ambient temperature T7	-40~140°C	41	obligate	
12	External coil (fin) T1	-40~140°C	42	obligate	
13	Internal coil (plate change) T4	-40~140°C	43	obligate	
14	Return gas temperature T2	-40~140°C	44	obligate	
15	Exhaust temperature T3	0~150°C	45	obligate	
16	Inlet water temperature T8	-40~140°C	46	obligate	
17	Effluent temperature T15	-40~140°C	47	obligate	
18	Economizer inlet T5	-40~140°C	48	obligate	
19	Economizer inlet T6	-40~140°C	49	obligate	
20	Unit tooling number	0~300	50	obligate	
21	Water tank temperature T16	-40~140°C	51	Hot water heat source temperature T12	-40~140°C
22	Fluorine road out antifreeze temperature T14	-40~140°C	52	Heating heat source temperature T11	-40~140°C
23	Drive manufacturer	0~10	53	Heating buffer tank temperature T10	-40~140°C
24	Water pump speed PWM	0~100%	54	Total effluent temperature T9	-40~140°C
25	Water flow	3~100L/min			
26	User return water temperature T13	-40~140°C			
27	obligate				

28	obligate				
29	obligate				
30	obligate				

3.2.6 Factory parameter setting method Single unit parameter setting

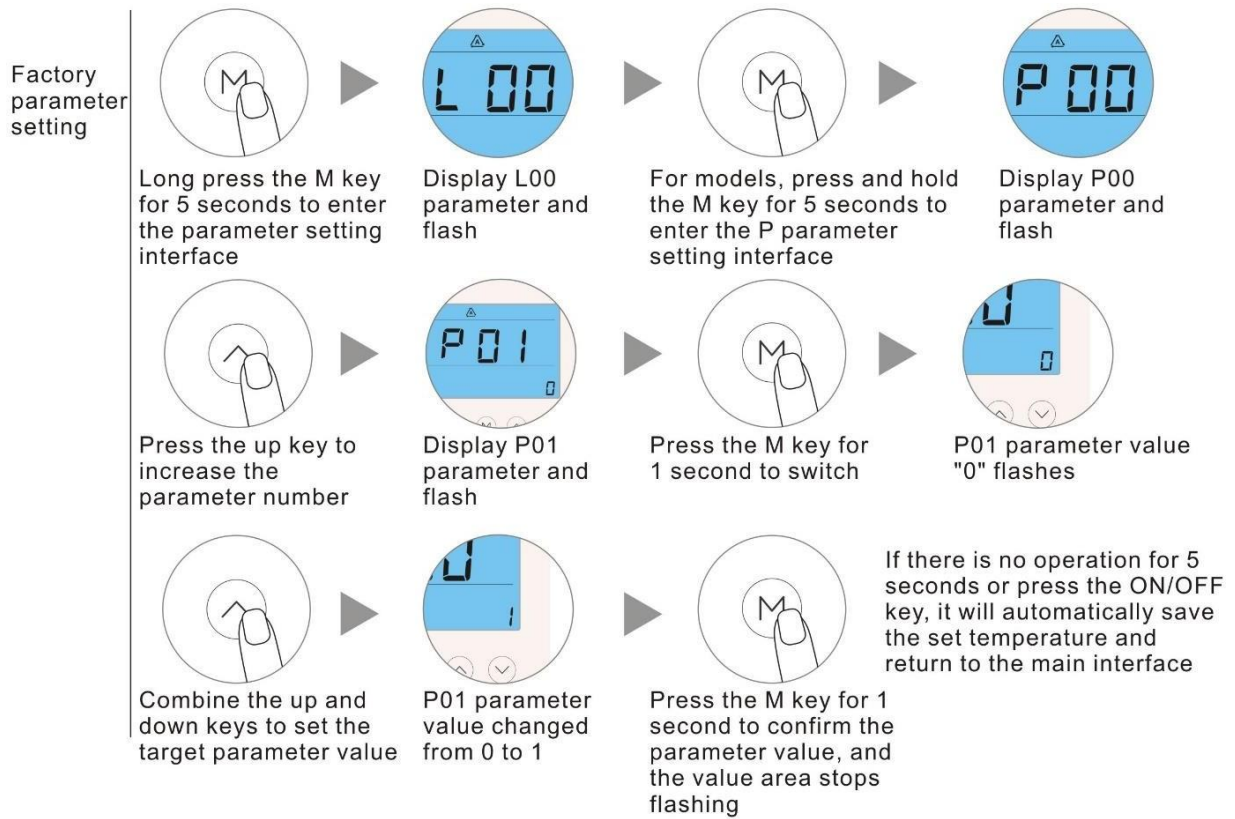

1. Parameter setting in master-slave cascade mode

Switch the master and slave through the clock key and M key in the setting parameter state, see the figure below

Master-slave
factory
parameter
setting

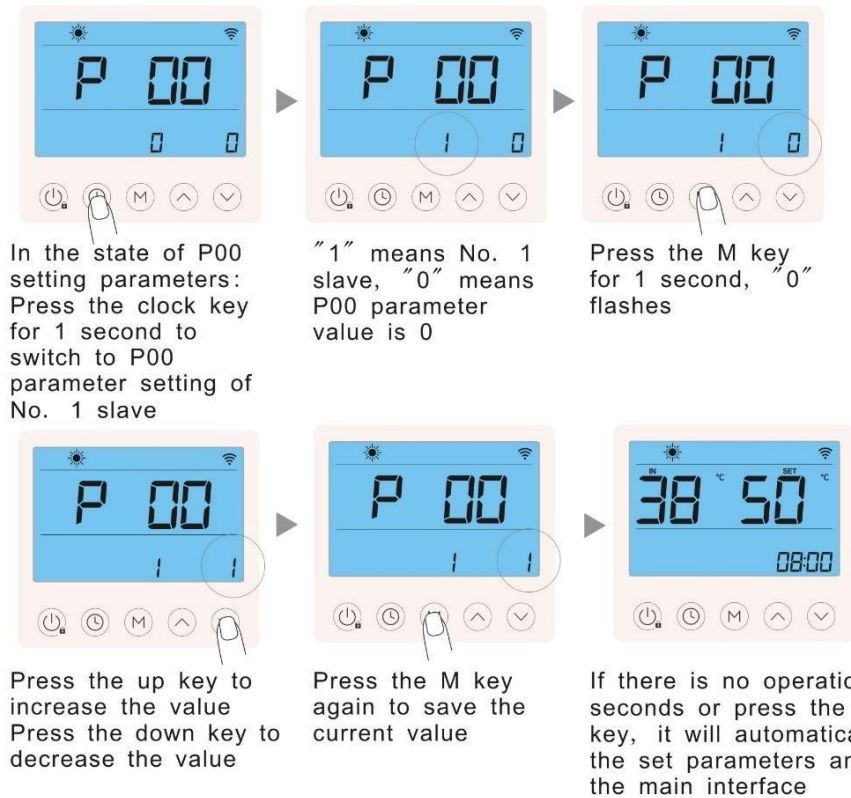

When the temperature control P150=3 is P_b the secondary water pump of the airconditioner, the temperature is set and operated

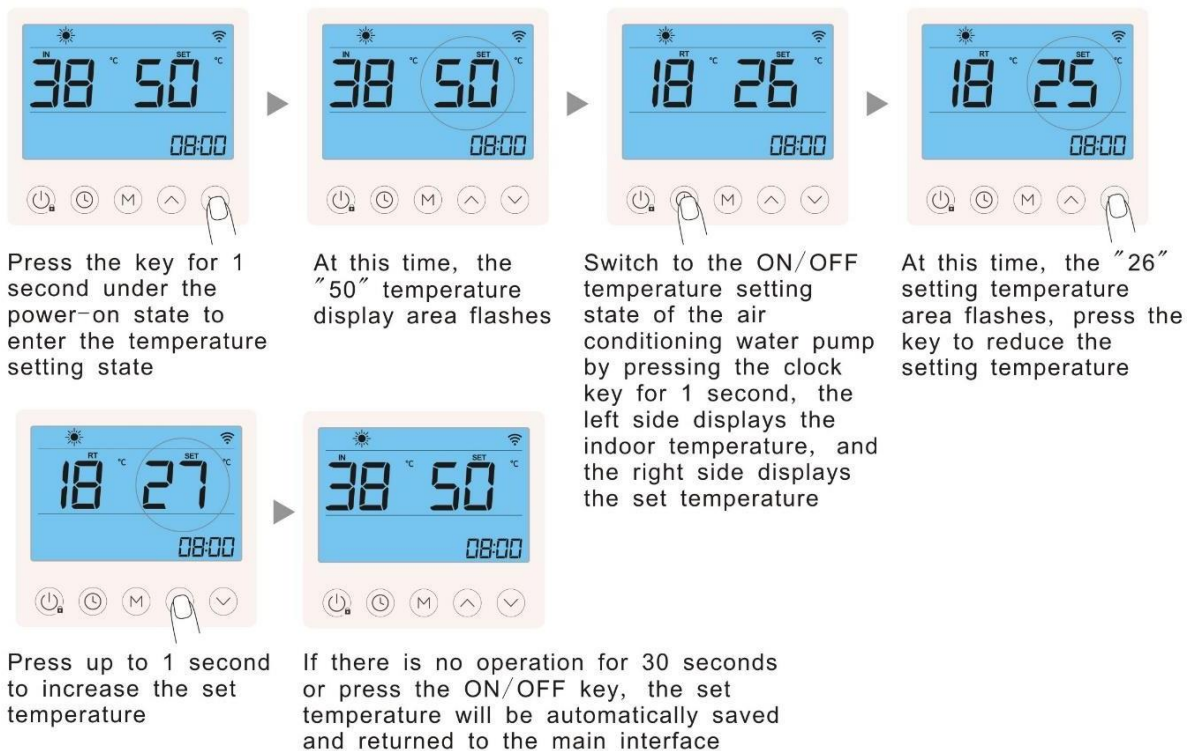

For more details about control functions, please refer to **【3.1.16AC water pump P_b】**

Enable and disable settings for hot water mode, high temperature sterilization, and hot water pipeline antifreeze

Enable and disable settings of hot water mode (P48):

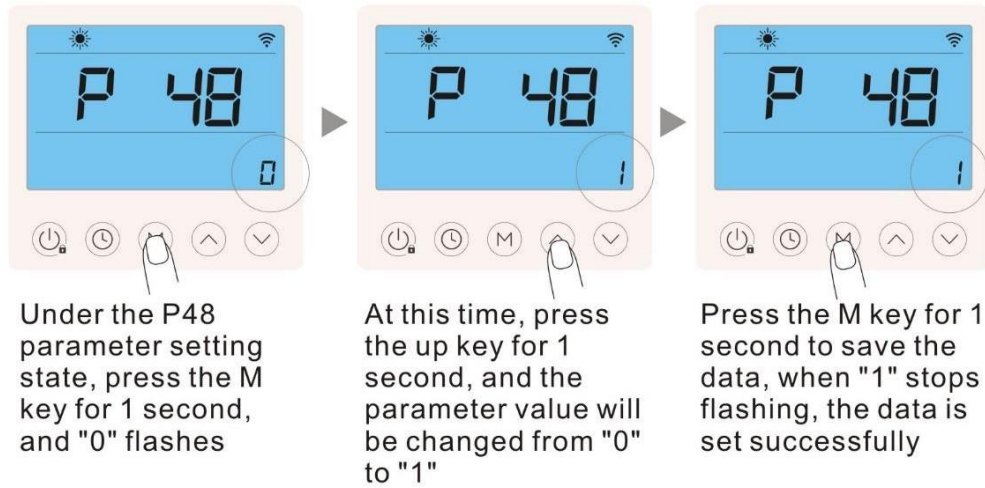

When P48 is set to 0, the hot water mode is enabled (factory default enabled), and the main interface has 7 modes to choose from (hot water, heating, cooling, hot water + heating, hot water + cooling, hot water + floor heating)

When P48 is set to 1, the main interface has 3 modes to choose from (heating, floor heating, cooling).

Enable and disable the high-temperature sterilization function (L12):

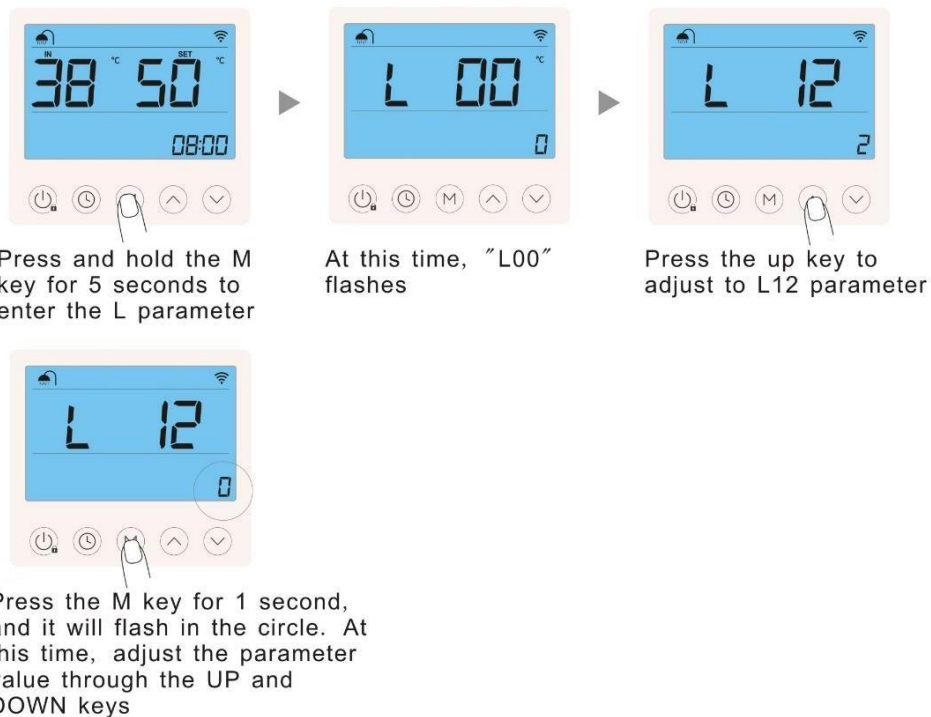

Sterilization function selection: [L12] = 0, automatic; [L12] = 1, disabled; [L12] = 2, manual, for more detailed control functions, please refer to [3.1.4 High Temperature Sterilization].

Manual forced start of high temperature sterilization function (when P140=0 and L12≠1).



Press and hold the ON/OFF key+the clock key+the DOWN key for 5 seconds in the unlocked state to enter the sterilization mode



The electric heating symbol is displayed



Press and hold the ON/OFF key+clock key+down key again for 5 seconds to exit the sterilization mode, and the electric heating symbol goes out

3.2.7 Factory reset



Press the key for 3 seconds in the off state

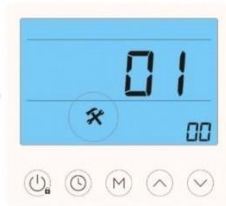

Enter the maintenance mode interface

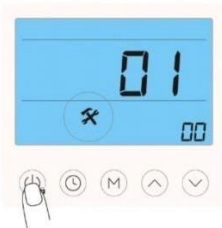

Press and hold the ON/OFF key for 5 seconds

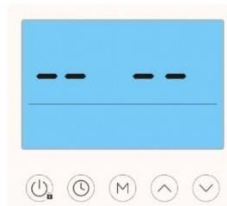

Restore factory settings successfully, and return to the main interface after 3 seconds

L parameter setting table

serial number	Parameter description	Factory parameters	range	remark
L0	Compressor manual control	0	0~1	0 Auto 1 Manual
L1	Compressor target frequency	0Hz	0~120Hz	
L2	Manual fan control	0	0~1	0 Auto 1 Manual
L3	Fan target frequency	0	0~70	0-70Hz (when PO6 chooses 1).
				Tap: 0 stop 1 low 2 medium ≥ 3 high wind
L4	Electronic expansion valve manually controlled	0	0~1	0 Auto 1 Manual
L5	Electronic expansion valve target number of steps	0	0~1	0-480P
L6	EVI manual control	0	0~1	0 Auto 1 Manual
L7	EVI target steps	0	0~1	0-480P
L8	DC water pump control	0	0~1	0 Auto 1 Manual
L9	DC water flow output	0	0~100	0 minimum output/100 maximum output
L10	PFC manual control	0	0~2	0 Auto 1 Off 2 On
L11				
L12	High temperature sterilization function	0	0~2	0 Auto 1 Disable 2 Manual
L13	Number of days between sterilization	7	5~30 days	
L14	Sterilization start time	23:00	00:00-24:00	
L15	Sterilization run time	10	0-50Min	
L16	Sterilization temperature setting	70°C	50-80°C	
L17	Water level control	1		0 Disabled/1 High Low/2 High High Low
L18	Hydration control	2		0 water level control / 1 water temperature + water level control
L19	Allow water replenishment temperature	45		
L20	Make-up temperature difference	5		
L21	Low water level disconnection operation			0 does not start/1 does not start at power-on/2 starts
L22	Backwater mode (host)	0	0~3	0: Disable / 1 continuous return / 2 cycle return / 3 temperature difference return water
L23	Inlet water temperature T8 (host).	40°C	20~65°C	

L24	Return water differential (host)	5°C	1~15°C	
L25	Backwater cycle (host)	30min	3~90min	
L26	Backwater time (host)	5min	1~30min	
L27				
L28				
L29				
L30				
L31				
L32				

P parameter setting table

number	Parameter description	range	remark
P00	obligate	0~1	
P01	High voltage switch setting	0~1	0 enables, 1 disables
P02	Low voltage switch setting	0~1	0 enables, 1 disables
P03	Water flow switch setting	0~1	0 enables, 1 disables
P04	Thermal overload protection switch setting	0~1	0 enables, 1 disables
P05	Linkage switch setting (host)	0~2	0 Enable 1 Disable 2 Constant Temperature Control
P06	Fan type settings	0~1	0 AC 1 DC 2EC fan
P07	High voltage protection lock setting	0~1	0: 3 locks1: No locks
P08	Low voltage protection lock setting	0~1	0: 3 locks1: No locks
P09	Exhaust protection lock setting	0~1	0: 3 locks1: No locks
P10	The water flow switch protects the lock settings	0~1	0: 3 locks1: No locks
P11	High voltage protection value	40~70	
P12	High voltage frequency limiting value	40~70	The setting value must be ≤ P11-5
P13	Low voltage protection value	-50~-10	
P14	Low voltage frequency limit value	-50~-10	
P15	Exhaust temperature protection value	100~120	
P16	Exhaust temperature frequency limit	90~120	The setting value must be ≤ P15-10
P17	Refrigeration fan lift value	0~60	
P18	Refrigeration fan speed reduction value	0~60	
P19	The speed reduction value of the heating fan	0~60	
P20	Heating fan lift value	0~60	
P21	Unit is prohibited from starting low temperature value (host)	-40~-10	
P22	Electric heating start-up ambient temperature (host)	-15~40	≤ P22 starts
P23	The temperature difference between the inlet and outlet water is too large (main engine)	10~30	≥ alarm
P24	Inlet water temperature T8 compensation value (main unit)	-10~10°C	
P25	Outlet temperature T15 compensation value (main unit)	-10~10°C	
P26	Air conditioner differential value (main unit)	0~10°C	
P27	Floor heating difference (host)	0~10°C	
P28	Pump control when the temperature is stopped (main unit)	0~4	0 operation / 1 stop / 2 cooling operation / 3 air conditioning operation / 4 floor heating operation
P29	Antifreeze pump operating time (every 10min)	0~10min	

P30	Defrost mode selection	0~2	0 smart 1 timing 2 fast
P31	Enter the cumulative run time threshold for defrosting	0~120	
P32	Enter the defrost coil temperature value	-30~0	
P33	Enter the defrost temperature difference 1	0~20	
P34	Enter the defrost temperature difference 2	0~20	
P35	Maximum defrosting time	0~30	

P36	Exit the defrost coil temperature	0~30	
P37	Darwin shutdown mode (host)	0~2	0 Intelligent1 Davan 2 Refrigeration Intelligence
P39	Pressure sensor settings	0~1	0 enables, 1 prohibits
P43	Medium voltage switch setting	0/1	1 Enable 0 Disable
P44	Water flow switch failure detection setup	0/1	0 enables, 1 disables
P45	Messaging address code	1~16	
P51	Minimum frequency limit for refrigeration	15-60Hz	
P52	The upper limit of the target frequency of refrigeration	40-120Hz	
P53	Lower limit of the target frequency for refrigeration	15Hz-P52	
P55	The upper limit of the heating target frequency	50-120Hz	
P56	Lower limit of heating target frequency	20Hz-P55	
P57	Minimum heating frequency 1	15-60Hz	Ring temperature > 0°C
P58	Minimum heating frequency 2	15-60Hz	-10°C ≤ Ring temperature < 0°C
P59	Minimum heating frequency 3	15-60Hz	Ring temperature < -10°C
P61	The upper limit of the target frequency of hot water	50-120Hz	
P62	Lower limit of target frequency for hot water	15Hz-P61	
P63	Minimum frequency of hot water 1	15-60Hz	Ring temperature > 0°C
P64	Minimum frequency of hot water 2	15-60Hz	-10°C ≤ Ring temperature < 0°C
P65	Minimum frequency of hot water 3	15-60Hz	Ring temperature < -10°C
P66	DC fan initial frequency	20-60Hz	Speed = frequency * 15
P67	DC wind mechanism thermal minimum frequency	20-60Hz	Speed = frequency * 15
P68	DC wind mechanism heat maximum frequency	20-60Hz	Speed = frequency * 15
P69	DC air mechanism cooling minimum frequency	20-60Hz	Speed = frequency * 15
P70	DC air mechanism cooling maximum frequency	20-60Hz	Speed = frequency * 15
P88	Silent mode compressor frequency	20-70Hz	
P89	Silent mode fan frequency	20-60Hz	Speed = frequency * 15
P95	Networking pump operation mode	0-1	0: Total 1: Independent
P96	Hot water return difference (host)	0~10°C	
P99	The water pump speed regulation temperature difference	2~10°C	
P100	PWM pump minimum speed	20~80%	Speed percentage
P101	Pump control method (main engine)	0~1	0 AC 1 DC PWM speed regulation
P103	Mode switching minimum run time	0~10min	When set to 0, it means no limit
P105	Cooling mode operating ring temperature limit (main unit)	10~60°C	
P106	Heating mode operating ring temperature limit (host)	10~60°C	Underfloor heating or heating
P107	Hot water mode operating ring temperature limit (host)	10~60°C	

P108	Hot water setting temperature limit (host)	30~80°C	
P109	Hot water setting lower temperature limit (host)	10~30°C	
P110	Heating setting temperature limit (main unit)	30~60°C	
P111	Lower temperature limit for heating setting (main unit)	15~30°C	
P112	Upper temperature limit for refrigeration setting (main unit)	20~40°C	

P113	Lower temperature limit for refrigeration setting (main unit)	5~20°C	
P114	Number of presses selected	1~2°C	1 single 2 double
P115	Model Selection (Host)	0~5	0: Two supply, 1: triple supply 2/3/4/5 reserved
P116	Unit temperature control mode (host)	0~1	0: return water / 1: water out
P117	Antifreeze enters the ring temperature	0~10°C	
P118	Antifreeze ingress temperature T15	0~20°C	
P119	Type of refrigerant	0~20	1:R410A, 2:R32, 3:R290
P120	Low temperature start-up limit	0~1	0 enables, 1 disables
P134	The water flow is too low to protect the value	0~100	0 is not detected
P135	Anti-condensation starts the temperature difference	0~50	Valid when P120 = 0
P136	The throttle bypass valve opens the ring temperature	-20~50	
P137	Throttled bypass valve delay press	0~999	
P138	Defrosting press frequency	40~120	
P139	Air conditioning electric heating option	0/2	0 enables, 1 disables, 2 gas controls
P140	Hot water electric heating option		0 enables, 1 disables, 2 gas controls
P141	Dew point duration of defrosting	0~60	min
P142	Dew point constant for defrosting		
P143	Defrosting can enter the water temperature		°C
P144	Defrosting can enter the ring temperature	-20~30	°C
P145	Effluent antifreeze protection value	-30~10	Freeze protection probe
P146	Pump range setpoint	0~100L/min	Set the maximum range value according to the pump model
P147	Refrigeration and antifreeze method	2000/1/2	0 low pressure 1 temperature 2 low pressure + temperature
P148	Refrigeration antifreeze temperature value	-40	Fluorine in/out
P149	The effluent is too high to limit the frequency	40-80	
P150	Secondary heating pump selection	2	
P151	Hot water heat source return	0	
P152	Heating heat source difference	0	

P153	Hot water heat source combined temperature upper limit	70	
P154	Heating heat source combined temperature ceiling	60	
P155	Compressor code selection (function reserved)	0	See compressor code table, 0: disabled
P158	The heating limit the water temperature and the starting ambient temperature	-15	When set to 30, the feature is disabled
P161	Auxiliary pump selection	0	0: Hot water/1: Air conditioning/2: Underfloorheating/3: Air-conditioned underfloor heating/4: All
P162	Hot water line antifreeze interval	90	Disabled when set to 0, unit: min
P163	The pump speed regulation minimum flow	30	L/min

P164	Energy level control	3	0 All Enabled / 1 Hot Water Enabled / 2 Heating Enabled / 3 All Disabled
P165	Load the difference	3	
P166	Load shedding differential returns	2	
P167	Emergency stop difference	3	
P168	Hot water mode start-up ratio	50	
P169	Non-hot water mode start-up ratio	100	
P170	Load cycle	7	
P171	Shield low voltage switch ring temperature value	-30	
P174	Defrost opening	450	

Table 3-5

3.3 Pump flow range setting method

The parameter setting value of P146 determines whether the feedback flow value of 25 status parameters is accurate, and different pump models have corresponding set values, as shown in the following table for details:



P146=62		P146=75		
(SHIMGE)				
APF25-12-130E FPWM1		APM25-9-130		
SOL-018HC3	SOL-024HC3	SOL-006HC1	SOL-010HC3	SOL-014HC3
				

Table 3-6

P146=66		P146=66		P146=35	
(GRUNDFOS)					
UPMXL 25-125		UPML 25-105		UPM3K 25-75	
SOL-018HC3	SOL-024HC3	SOL-014HC3		SOL-006HC1	SOL-010HC3
					

Table 3-7

P146=90			P146=70		
(Shinhoo)					
GPA25-11H			GPA25-9H		
SOL-014HC3	SOL-024HC3	SOL-006HC1	SOL-010HC3	SOL-014HC3	
					

Table 3-8

3.4 Layout of outdoor unit electric control box

3.4.1 SOL-006HC1/ SOL-010HC3/ SOL-014HC3/ SOL-014HC3

AP4 switching power stripPCB

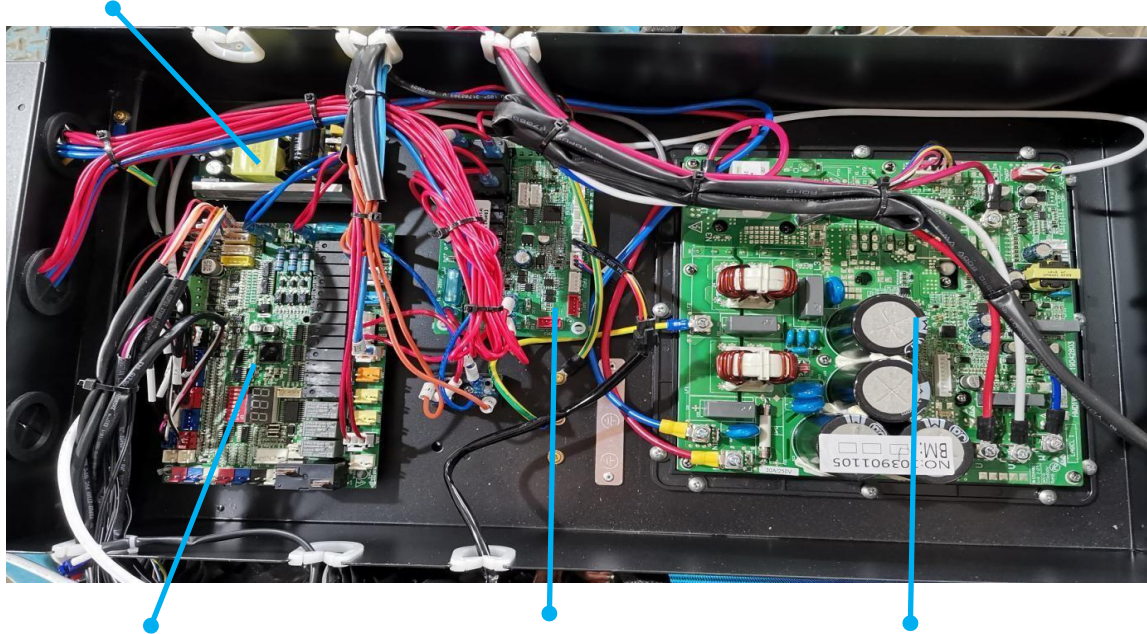

AP1 main control board PCB

AP3 water pump expansion board PCB

AP2 driver board PCB

3.4.2 SOL-018HC3

AP4 switching power strip PCB

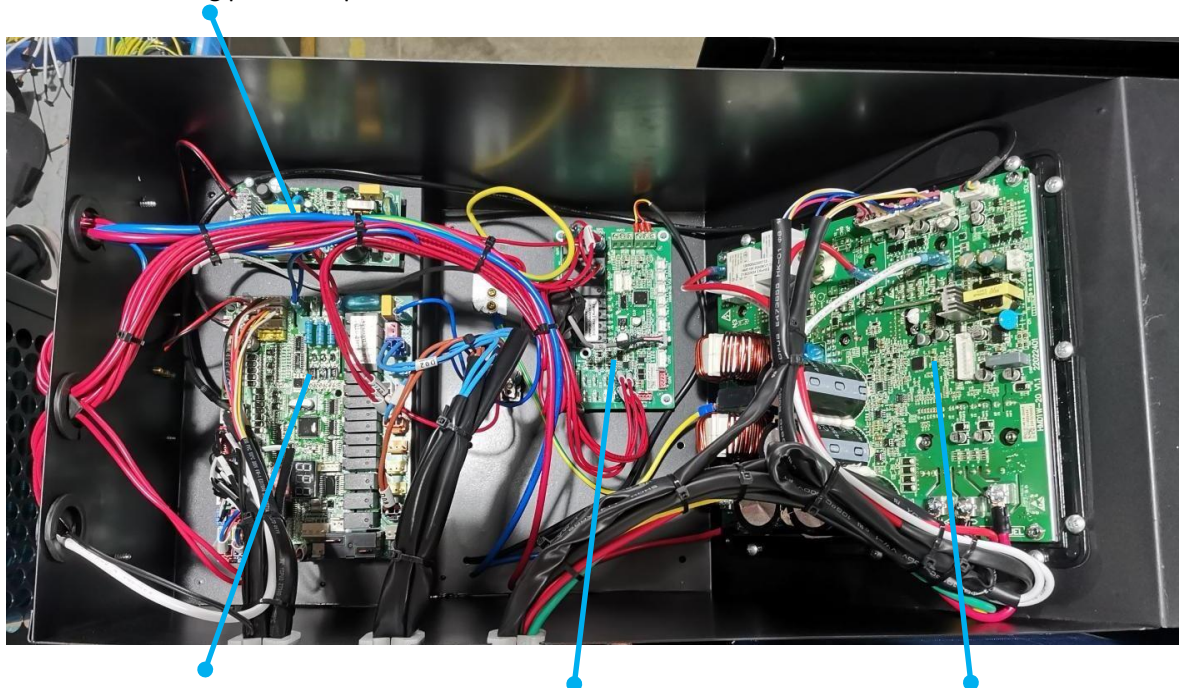

AP1 Main control board PCB

AP3 Water pump expansion plate PCB

AP2 Compressor driven

3.4.3 SOL-006HC1/ SOL-010HC3/ SOL-014HC3/ SOL-018HC3

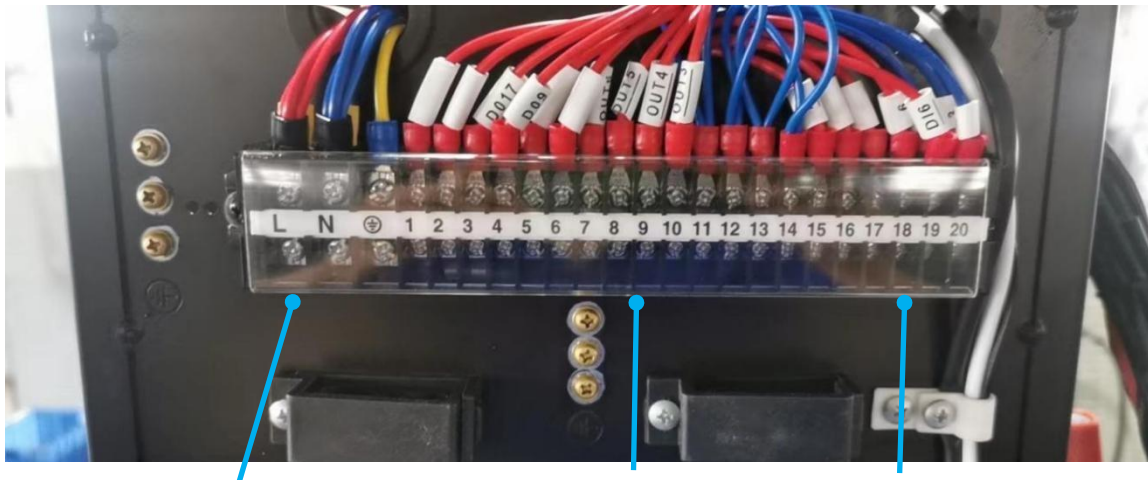

XT1 Power input 230VAC

1-14: 220VAC

15-20: DC12V

3.4.4 SOL-010HC3/ SOL-014HC3

AP2 Switching power strip PCB

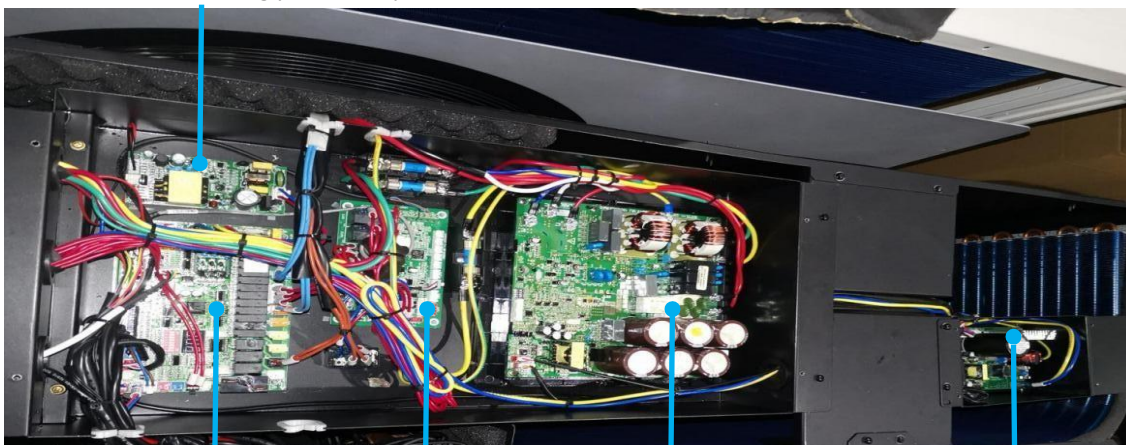

AP1 Main control board

AP3 Water pump expansion board

AP2 Compressor driver board

AP5 fan power strip P

3.4.45 SOL-018HC3

AP2 Switching power strip PCB

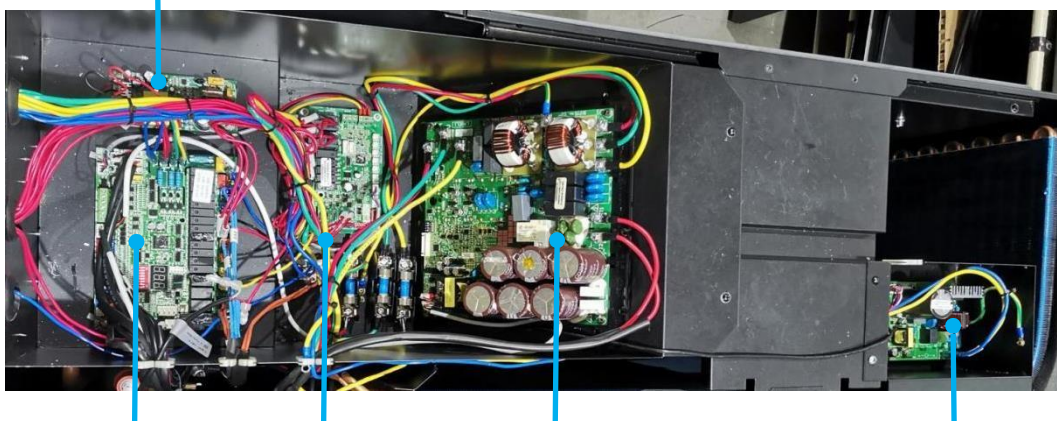

3.4.6 SOL-006HC1/ SOL-010HC3/ SOL-014HC3/ SOL-018HC3 / SOL-024HC3

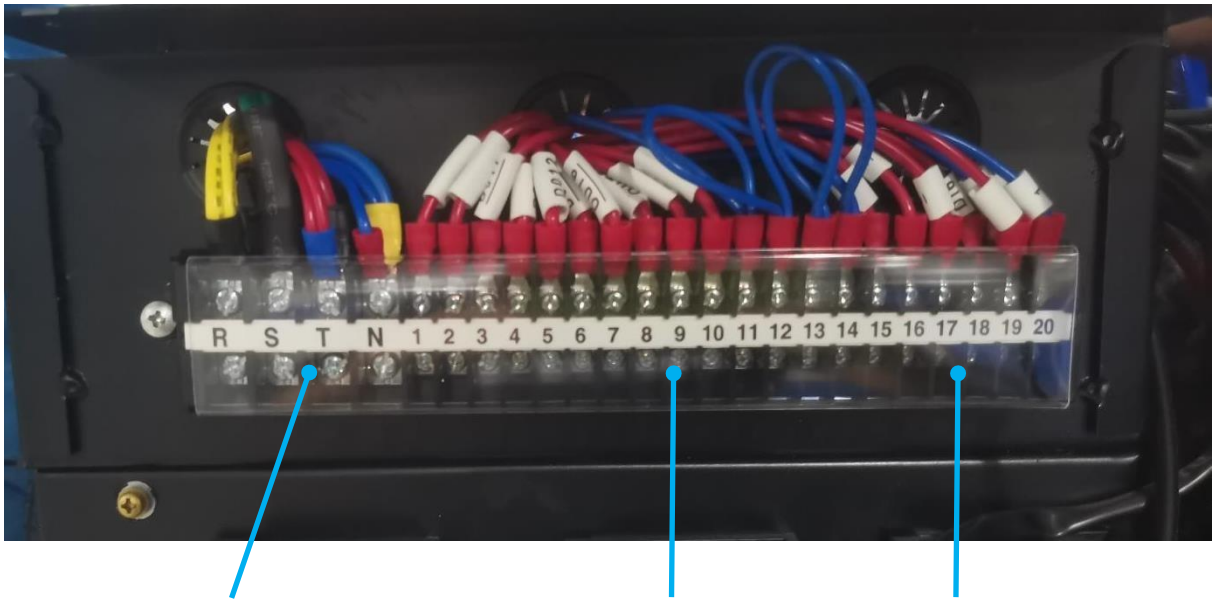

XT1 power input 400VAC

1-14: 230VAC

15-20: DC12V

3.5 Electrical PCB Diagrams

3.5.1 Main Control Board Port Definition Diagram (AP1)

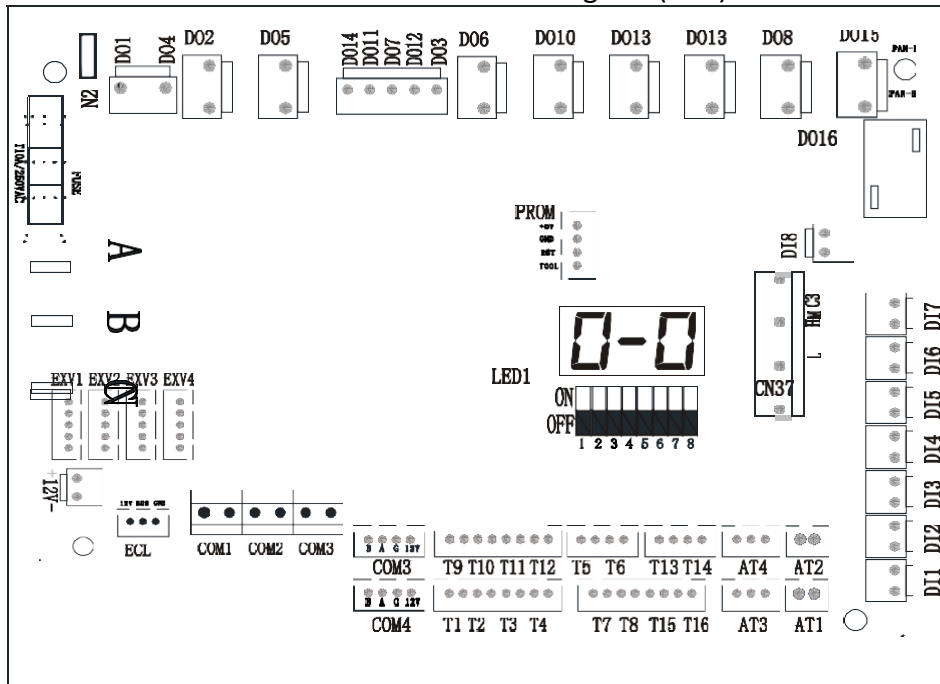

port	description	port	description	port	description
D01	Hot water electric heating/gas signal output	DI3	Water flow switch	A13	Low voltage sensors
D02	4-way valve	DI2	Low voltage switch	T1	External coil temperature
D03	Liquid spray valve	DI1	High voltage switch	T2	Return air temperature
D04	Throttled bypass valve	C3	The common end of the water level	T3	Exhaust temperature
D05	obligate	H	High water level (hot water)	T4	Refrigeration coil temperature
D06	Return valve	M	Medium water level (hot water)	T5	Economizer inlet temperature
D07	The crankshaft is heated	L	Low water level (hot water)	T6	Economizer outlet temperature
D08	Chassis heating	A12	obligate	T7	Outdoor ambient temperature
D09	Electric heating for heating	A11	obligate	T8	Inlet water temperature
D010	EH3: Expansion tank heating	A14	High pressure sensors	T9	Total effluent temperature sensor (optional)
D011	P_e: Auxiliary heat source pump on the hot water side	COM3	Drive module	T10	Heating tank temperature sensor (optional)
D012	P_f: Auxiliary heat source pump on heating side	COM4	LCD wire controller	T11	Heating side heat source temperature sensor (optional)
D013	EH4: Plate swap heating	COM3	obligate	T12	Hot water side heat source temperature sensor (optional)
D014	Enthalpy increase valve	COM2	Upper computer monitoring	T13	User return temperature
D015	Low wind	COM1	Module cascade	T14	Antifreeze temperature
D016	High wind	ECL	Expansion modules	T15	Outlet temperature
D017	P_c Hot Water Auxiliary Pump (Optional)	12V	DC 12V power supply	T16	Tank temperature (hot water)
C2	Public side 1	EXV1	EEV main valve	LED1	Nixie tube
C1	Public side 2	EXV2	EVI auxiliary valve	SW1	DIP switch
DI8	Medium voltage switch 1	C	Power input T phase	N	Power input neutral wire
DI7	obligate	B	Power input S phase		
DI6	Host linkage switch	A	Power input R phase		

3.5.2 Pump expansion board port definition diagram (AP3)

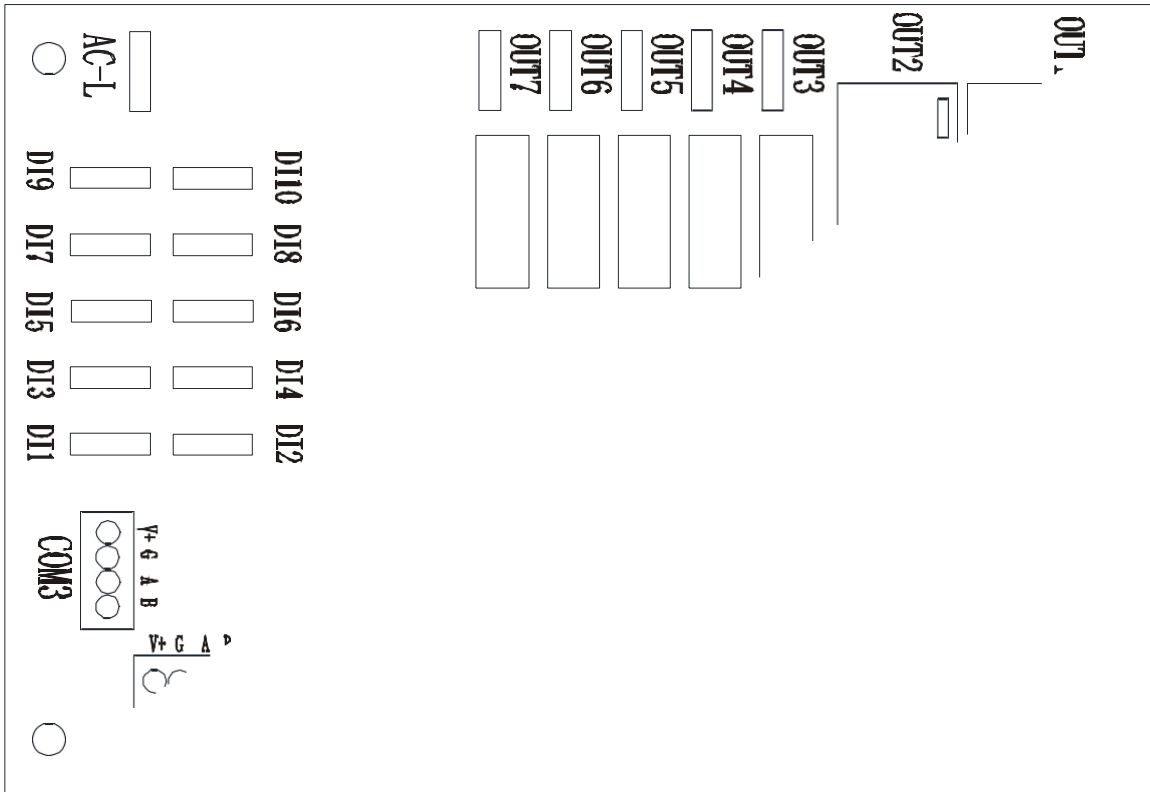

serial number	port	description	serial number	port	description
1	OUT1	Circulating water pump	18	DI6	Heating secondary circulation pump linkage switch
2	OUT2	P_b: Heating secondary circulation pump	19	DI5	GND
3	OUT3	SV1: Air conditioner valve closed	20	DI4	Heat source heating side linkage switch
4	OUT4	SV1: Air conditioner valve open	21	DI3	GND
5	OUT5	SV2: Hot water valve open	22	DI2	Heat source hot water side linkage switch
6	OUT6	SV2: Hot water valve closed	23	DI1	GND
7	OUT7	Hot water electric heating/gas signal output	24	TH1	obligate
8	DI10	obligate	25	TH2	obligate
9	DI9	GND	26	TH3	obligate
10	DI8	obligate	27	TH4	obligate
11	DI7	GND	28	TH5	obligate
12	COM3	RS485	29	COM 8	Water flow meter
13	COM2	RS485	30	ECL	Communicate with the main control board
14	COM1	RS485	31	COM 4	Indoor pump PWM input and output
15	AC-L	Firewire input	32	COM 6	Main engine circulation pump PWM input and output

Spare motherboard

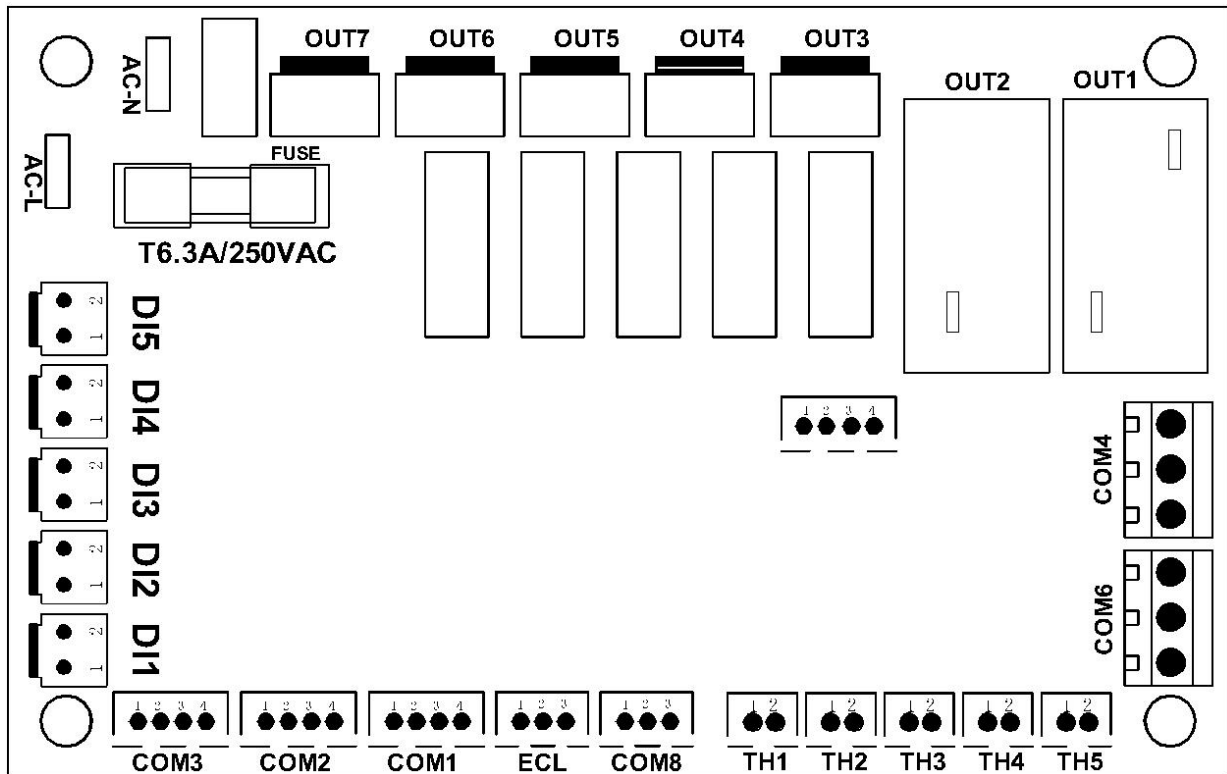

serial number	port	description	serial number	port	description
1	OUT1	Circulating water pump	18	DI6	obligate
2	OUT2	P_b: Heating secondary circulation pump	19	DI5	obligate
3	OUT3	SV1: Air conditioner valve closed	20	DI4	Heating secondary circulation pump linkage switch
4	OUT4	SV1: Air conditioner valve open	21	DI3	Heat source heating side linkage switch
5	OUT5	SV2: Hot water valve open	22	DI2	Heat source hot water side linkage switch
6	OUT6	SV2: Hot water valve closed	23	DI1	GND
7	OUT7	Hot water electric heating/gas signal output	24	TH1	obligate
8	COM3	RS485	25	TH2	obligate
9	COM2	RS485	26	TH3	obligate
10	COM1	RS485	27	TH4	obligate
11	AC-L	Firewire input	28	TH5	obligate
12	AC-N	Neutral line input	29	COM8	Water flow meter
13			30	ECL	Communicate with the main control board
14			31	COM4	Indoor pump PWM input and output
15			32	COM6	Main engine circulation pump PWM input and output

Table 3-11

3.5.3 Switching power supply port definition diagram (AP4)



3.5.4 DC fan board port definition diagram (AP5)

2# DC fan DC310V

1# DC fan DC310V

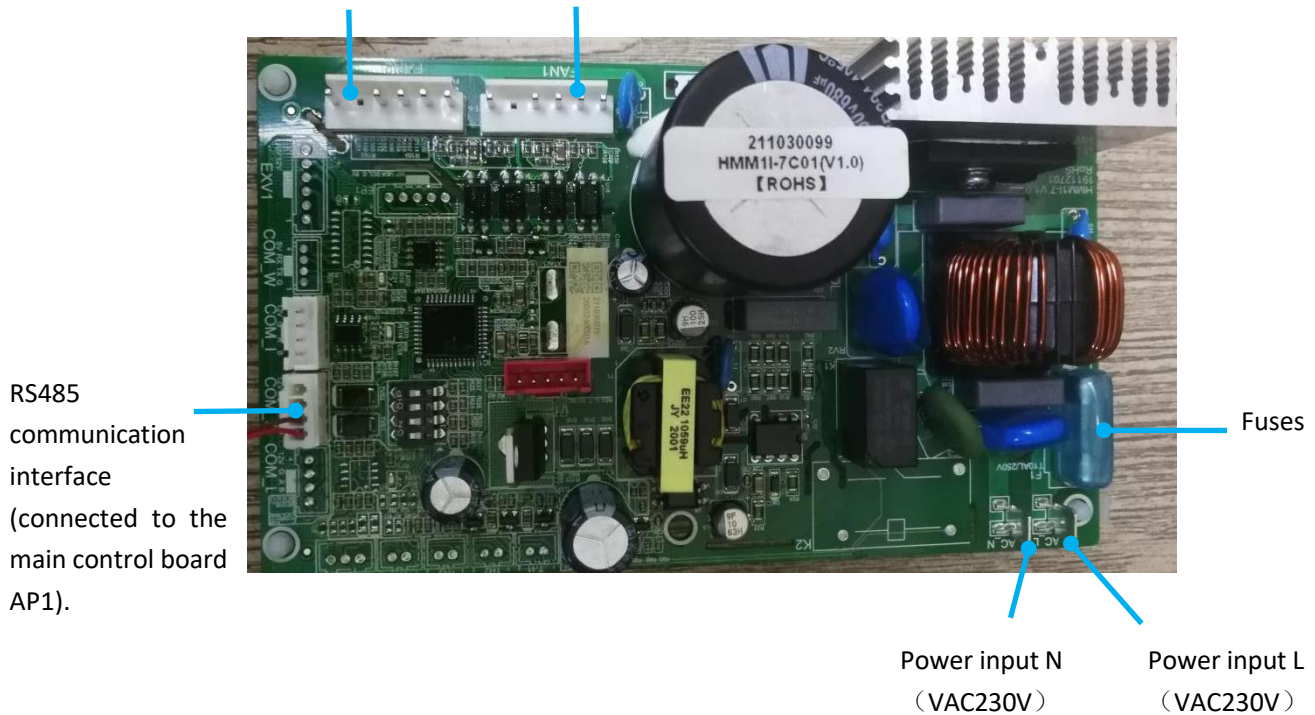

3.5.5 Compressor drive board port definition diagram (AP4)

1. Applicable models SOL-006HC1、SOL-010HC1

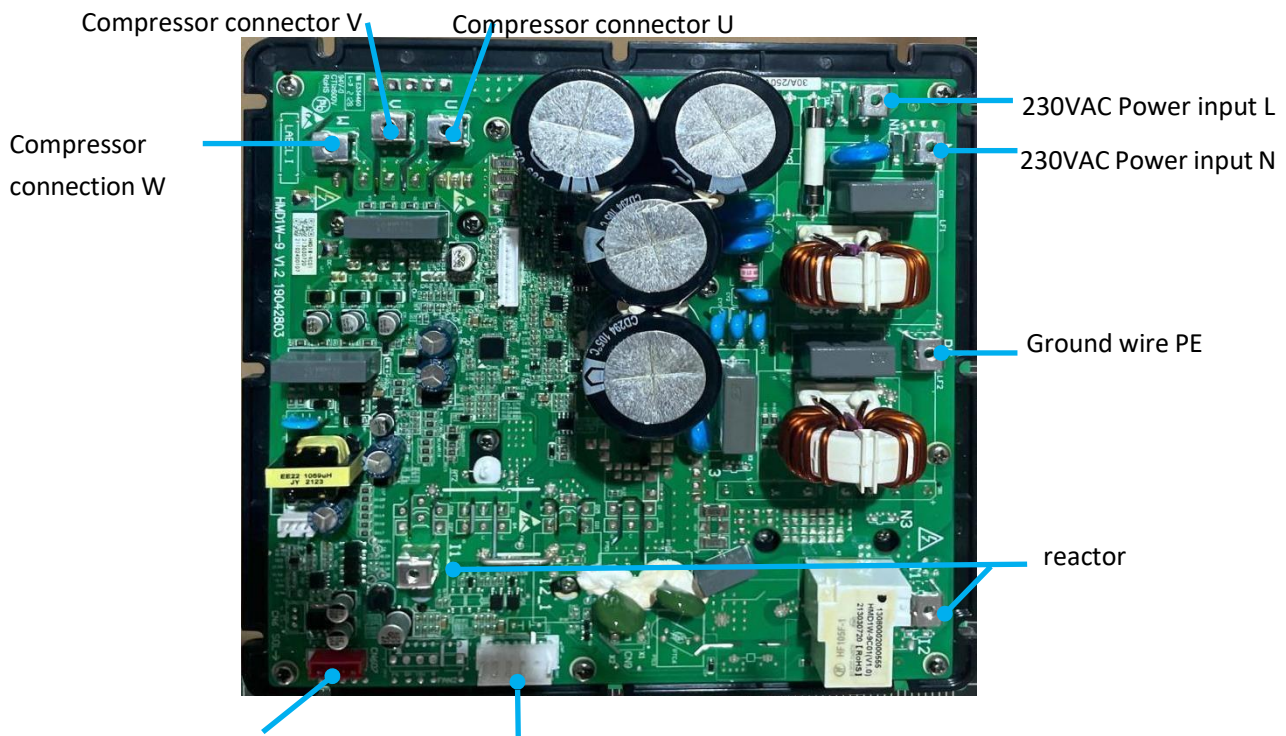

RS485 communication is connected to the AP1 main control board

DC fan interface

Applicable models SOL-014HC1、SOL-018HC1

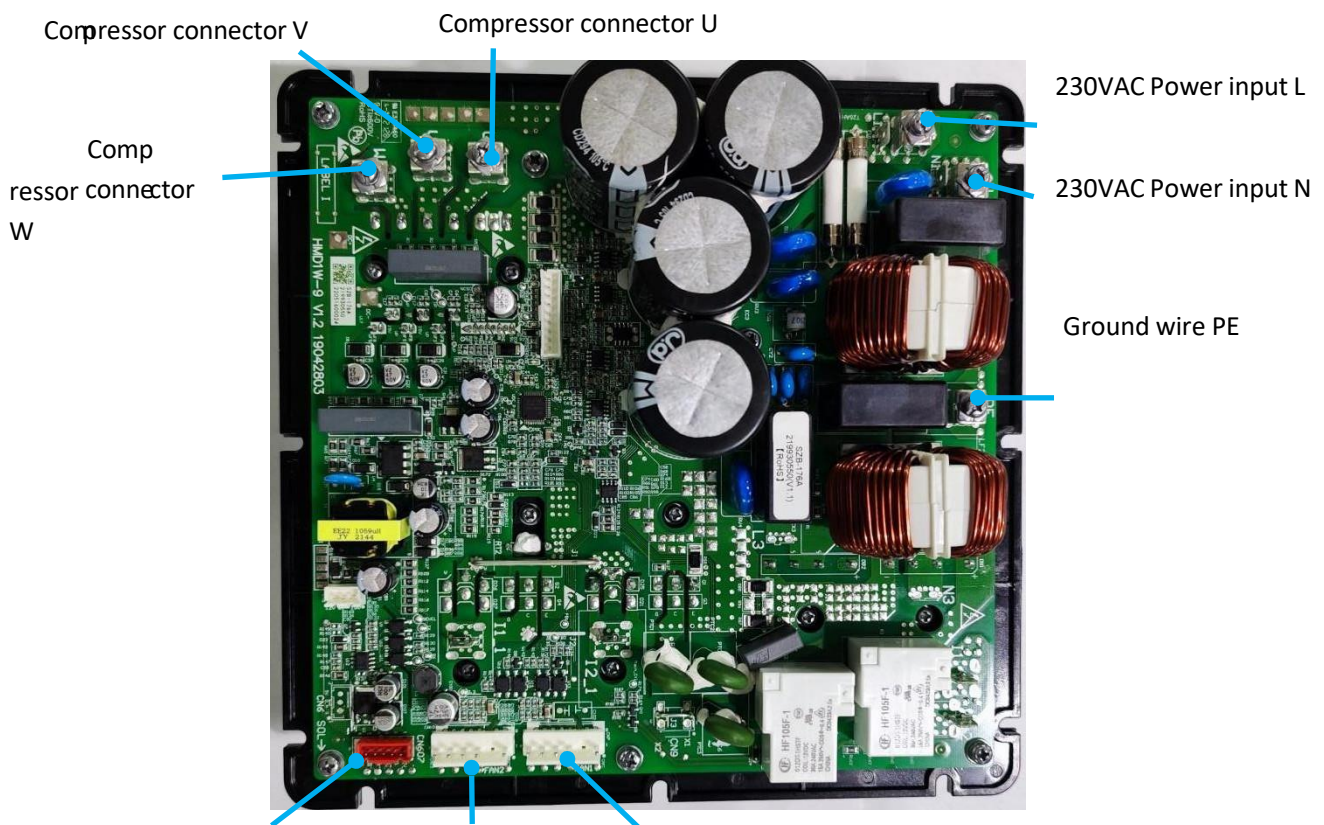

RS485 communication is 2# DC fan 1# DC fan interfa

Applicable models SOL-018HC3 , SOL-024HC3

RS485 Communication is connected to the AP5 DC fan board

RS485 communication is connected AP1 main control board

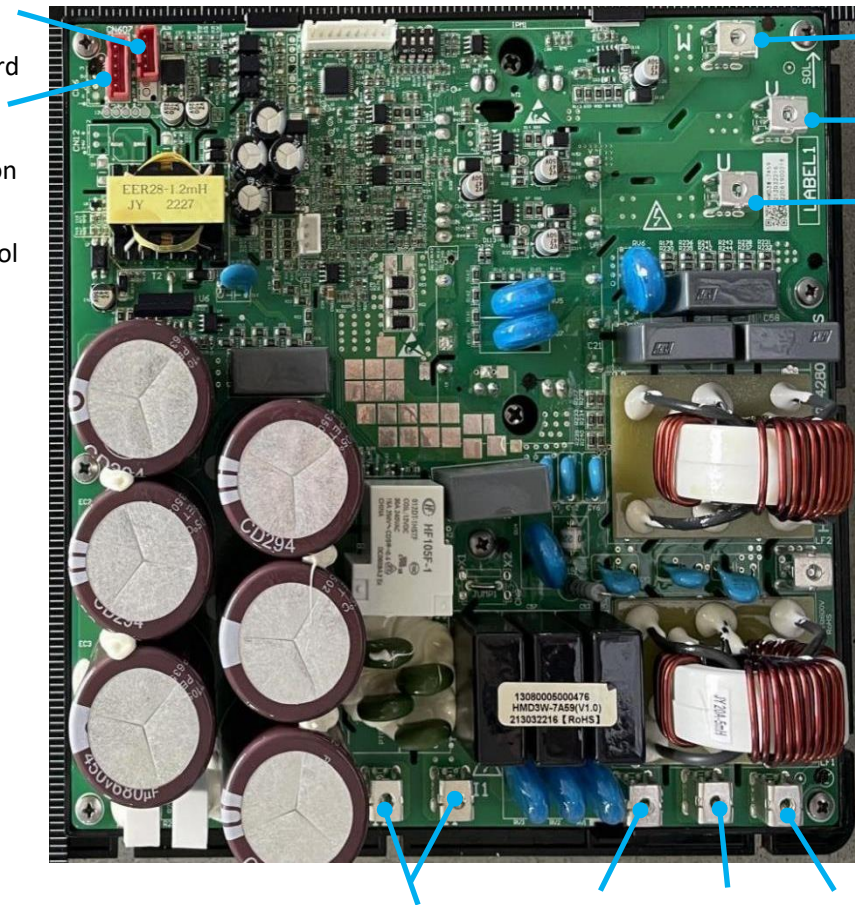

Compressor interface W
Compressor interface V
Compressor interface U

reactor Power input R Power input S Power input

AP1 Main Control Board- Temperature Sensors T9/T10/T11/T12/T16 (Enable and Disable):

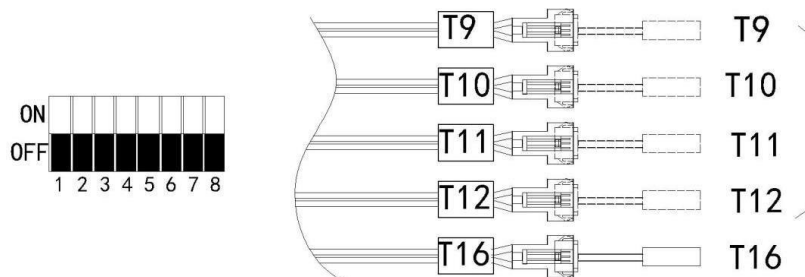

1. T9 total outlet temperature is enabled, dial code 7=ON (not enabled by default)
2. T10 heating water tank temperature enabled, dial code 6=ON (default not enabled)
3. The temperature of the heat source on the heating side of T11 is enabled, and P151 is set to non-0 (factory default 0 is not enabled).
4. The heat source temperature on the hot water side of T12 is enabled, and P152 is set to non-0 (factory default 0 is not enabled).
5. T16 hot water tank temperature (factory standard).

3.6 Fault code and cause of failure

Failure code	Fault description	Troubleshooting and the cause of the failure
E 01	Out-of-phase protection	The power supply phase sequence is incorrect
E 02	Phase loss fault	The power supply is out of phase
E 03	Protection against water flow switch failure or low water flow	1. Whether the circulating water pump is normal and whether the water system is blocked
		2. Whether the water flow switch model is normal and whether the installation direction is correct
		3. Whether the water flow switch port wiring is correct
		4. Whether the pump lift meets the actual requirements
		5. Whether the water pump is reversed and the installation direction is wrong
E 04	Abnormal communication between the main control board and the remote module (reserved)	Check the communication connection between the motherboard and the remote module
E 05	High voltage switch failure	1. Whether the pressure switch is damaged and the wiring is wrong
		2. Too much refrigerant in the system
		3. Whether the fan works normally and whether the water flow of the unit is normal
		4. The air inlet in the fluorine circuit system may be blocked
		5. Whether the water-side heat exchanger is seriously formed
E 06	Low voltage switch failure	1. Whether the pressure switch is damaged and whether the wiring is correct
		2. Lack of refrigerant in the system
		3. Whether the fan works normally
		4. There is blockage in the fluorine circuit system
E 09	The remote controller is communicating with the motherboard is faulty	Check the communication connection between the remote and the motherboard
AND 10	obligate	obligate
AND 11	Time-limited protection	The free trial period has arrived, enter the boot password
E 12	Exhaust temperature is too high fault	1. The fluorine system is blocked
		2. Lack of refrigerant in the fluorine circuit system or bad sensor
AND 14	Hot water tank temperature failure	1. The sensor connection wire is disconnected or short-circuited
		2. The sensor is damaged
		3. The motherboard port is damaged
AND 15		1. The sensor connection wire is disconnected or short-circuited

	The inlet water temperature sensor is faulty	2. The sensor is damaged
		3. The motherboard port is damaged
E 16	Coil sensor failure	1. The sensor connection wire is disconnected or short-circuited
		2. The sensor is damaged
		3. The motherboard port is damaged
AND 18	Exhaust sensor failure	1. The sensor connection wire is disconnected or short-circuited
		2. The sensor is damaged
		3. The motherboard port is damaged
E 20	Room temperature sensor failure	1. The sensor connection wire is disconnected or short-circuited
		2. The sensor is damaged
		3. The motherboard port is damaged
E 21	Environmental sensor failure	1. The sensor connection wire is disconnected or short-circuited
		2. The sensor is damaged
		3. The motherboard port is damaged
E 22	User backwater sensor failure (hot water)	1. The sensor connection wire is disconnected or short-circuited
		2. The sensor is damaged
		3. The motherboard port is damaged
E 23	Refrigeration subcooling protection	1. Check whether the water flow is too low or no water flow
		2. Check whether the outlet probe is damaged
		3. The fluorine system is blocked
AND 24	Fluorine circuit antifreeze temperature fault (fluorine road)	1. The sensor connection wire is disconnected or short-circuited
		2. The sensor is damaged
		3. The motherboard port is damaged
E 25	obligate	obligate
E 26	Freeze sensor failure (waterway)	1. The sensor connection wire is disconnected or short-circuited
		2. The sensor is damaged
		3. The motherboard port is damaged
E 27	The effluent sensor is faulty	1. The sensor connection wire is disconnected or short-circuited
		2. The sensor is damaged
		3. The motherboard port is damaged
E 29	Return air sensor failure	1. The sensor connection wire is disconnected or short-circuited
		2. The sensor is damaged
		3. The motherboard port is damaged
E 30	Return air sensor failure	1. The sensor connection wire is disconnected or short-circuited
		2. The sensor is damaged

		3. The motherboard port is damaged
E 31	Water pressure switch failure	1. The water pressure switch wiring is wrong 2. Water pressure switch failure
E 32	Excessive effluent temperature protection	1. Insufficient water flow 2. The sensor is damaged
E 33	High pressure sensor failure	1. The sensor connection wire is disconnected or short-circuited 2. The sensor is damaged 3. The motherboard port is damaged
E 34	Low voltage sensor failure	1. The sensor connection wire is disconnected or short-circuited 2. The sensor is damaged 3. The motherboard port is damaged
E 37	The temperature difference between the inlet and outlet water is too large to protect	1. The water inlet or outlet probe is damaged 2. The inlet or outlet probe is not placed in the wrong position 3. Insufficient water flow
E 38	DC fan failure	The fan drive board or motor is damaged
E 42	Refrigeration coil sensor failure	1. The sensor connection wire is disconnected or short-circuited 2. The sensor is damaged 3. The motherboard port is damaged
E 44	Ambient temperature too low protection	Normal protection
E 47	The economizer inlet sensor is faulty	1. The sensor connection wire is disconnected or short-circuited 2. The sensor is damaged 3. The motherboard port is damaged
E 48	The economizer inlet sensor is faulty	1. The sensor connection wire is disconnected or short-circuited 2. The sensor is damaged 3. The motherboard port is damaged
E 49	The economizer outlet sensor is faulty	Same as E47
E 51	High voltage too high protection	Same as E05
E 52	Low voltage too low protection	Same as E06
E 55	Expansion board communication abnormal	1. Poor contact or broken signal line 2. The expansion board is damaged 3. The motherboard is damaged
E 80	Power supply error	The single-phase power supply unit detected a three-phase electrical signal

E 88	Variable frequency drive module protection	The compressor or compressor drive board is bad, and the failure is shown in Appendix 1
E 94	The main engine circulating water pump is under pressure	1. Input power supply voltage < 165V
		2. Input voltage > 265V
		3. The electronic components on the pump drive board are damaged or damp
		4. The water pump is damaged
E 96	The communication between the press drive and the main control board is abnormal	1. Poor contact or broken signal line
		2. The electronic components on the main control board are damaged or damp
		3. The electronic components on the press drive board are damaged or damp
		4. The power supply of the press drive board is not energized
E 98	The communication between the fan drive and the main control board is abnormal	1. Poor contact or broken signal line
		2. The electronic components on the main control board are damaged or damp
		3. The electronic components on the fan drive board are damaged or damp
		4. The power supply of the fan drive board is not energized
AND A1	The networking model is incorrect	Different series of units are not allowed to be networked
AND A2	Hot water heat source sensor failure	1. The sensor connection wire is disconnected or short-circuited
		2. The sensor is damaged
		3. The motherboard port is damaged
AND A3	Heating heat source sensor failure	1. The sensor connection wire is disconnected or short-circuited
		2. The sensor is damaged
		3. The motherboard port is damaged
AND A4	Heating tank sensor failure	1. The sensor connection wire is disconnected or short-circuited
		2. The sensor is damaged
		3. The motherboard port is damaged
AND A5	Total effluent sensor failure (multiple networking)	1. The sensor connection wire is disconnected or short-circuited
		2. The sensor is damaged
		3. The motherboard port is damaged

Table 3-12

Compressor drive description is attached in Table 1		
E88	P1	IPM overcurrent/IPM module protection
	P2	Compressor drive failure/software control abnormal/compressor out of step
	P3	Compressor overcurrent
	P4	Input voltage phase loss (single phase invalid)
	P5	IPM current sampling fault
	P6	power component overheating shutdown;
	P7	Precharge failed
	P8	DC link overvoltage
	P9	The DC link is undervoltage
	P10	AC input undervoltage
	P11	AC input overcurrent
	P12	Input voltage sampling failure
	P13	DSP-PFC communication failure
	P14	Radiator temperature sensor failure
	P15	DSP and communication board communication failure
	P16	Abnormal communication with the main control board
	P17	Compressor overcurrent alarm
	P18	Compressor field weakening protection alarm
	P19	IPM overtemperature alarm
	P20	PFC overheating alarm
	P21	AC input overcurrent alarm
	P22	EEPROM fault alarm
	P23	ON
	P24	EEPROM refresh completes (can be eliminated after reboot);
	P25	Temperature sensing fault frequency limiting;
	P26	AC undervoltage frequency limit protection alarm;
	P27	ON
	P28	ON
	P29	:ON
	P30	ON
	P31	ON
	P32	ON
	P33	IPM module overheating shutdown

P34	The compressor is out of phase
P35	The compressor is overloaded
P36	Input current sampling fault
P37	IPM supply voltage failure
P38	Precharge circuit voltage failure
P39	EEPROM failure
P40	AC input overvoltage fault
P41	Microelectronics malfunction
P42	Compressor model code failure
P43	Current sampling signal overcurrent (hardware overcurrent)
The remote controller flashes to cycle through the E88 and above codes	

Table 3-13

3.7 Waterway installation and wiring

3.7.1 The system legend illustrates the comparison

Legend code comparison table

code name	Assembly unit	code name	Assembly unit
0	Heat pump host	DC 3	Auxiliary heat source water pump on heating side P_e linkage switch
1	Exhaust valve	DC 4	The auxiliary heat source water pump on the hot water side P_f linkage switch
2	Water flow switch	T15	Outlet water temperature T15 sensor
3	Pressure relief valve	T16	Hot water tank temperature sensor
4	Expansion tank	T10	Buffer tank temperature sensor (optional)
5	Shut-off valves (individual purchase)	T9	Total effluent temperature T15 sensor (optional)
6	Filters (individual purchases)	T11	Heating side heat source temperature sensor (optional)
7	Check valves (individual purchase)	T12	Hot water side heat source temperature sensor (optional)
8	Bypass valves (individual purchase)	P_a	Main engine circulation pump (PWM)
9	Buffer tank	P_b	Heating secondary circulation pump (individual purchase)
10	Domestic hot water tank	P_c	Auxiliary pump (individual purchase)
EH1	Hot water tank electric heating/gas control signal	P_d	User return pump (individual purchase)
EH2	Electric heating of heating water tank (individual purchase)	P_e	Hot water side auxiliary heat source pump (individual purchase)
SV1	Electric 3-way valve for hot water (individual purchase)	P_f	Heating side auxiliary heat source pump (individual purchase)
SV2	Air conditioner electric three-way valve (individual purchase)	P_g	Gas circulation pump (individual purchase)
T8	Inlet water temperature sensor	KA1- KA4	Intermediate relays (individual purchase)
AH S	Additional heat source (wall-hung stove) (individual purchase).	KM1- KM4	AC contactor (individual purchase)
DC 1	Unit linkage switch		
DC 2	Heating secondary water pump P_b linkage switch		

3.7.2 Installation diagram of a single floor heating mode waterway system

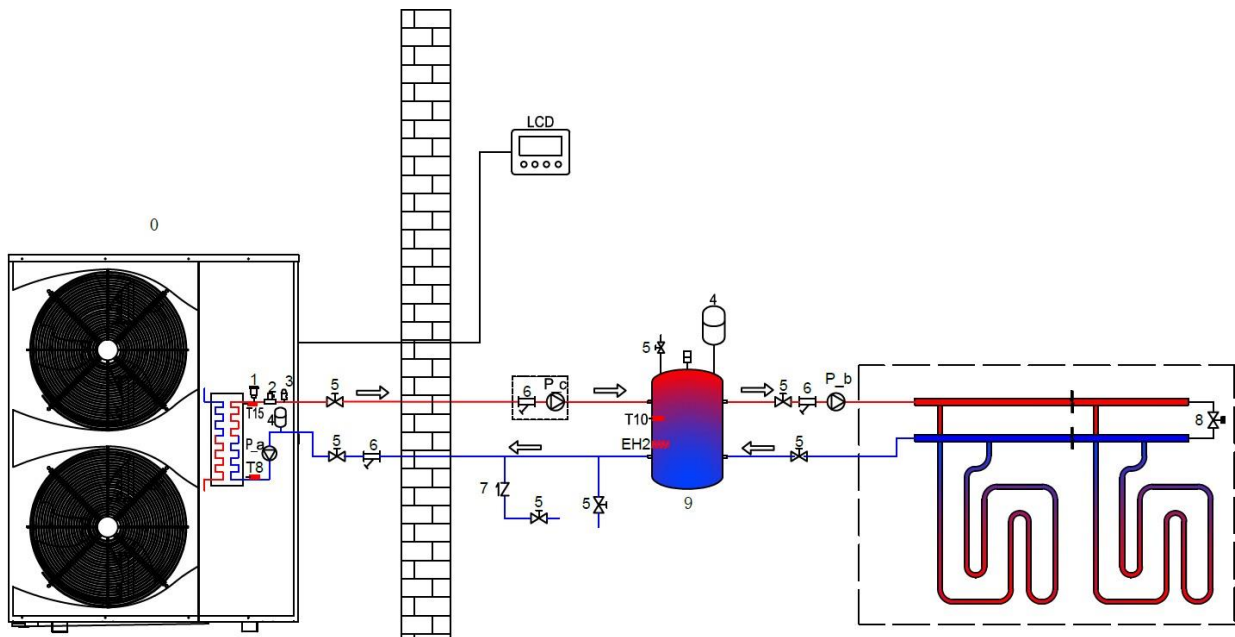

Installation diagram of the heating or cooling mode waterway system

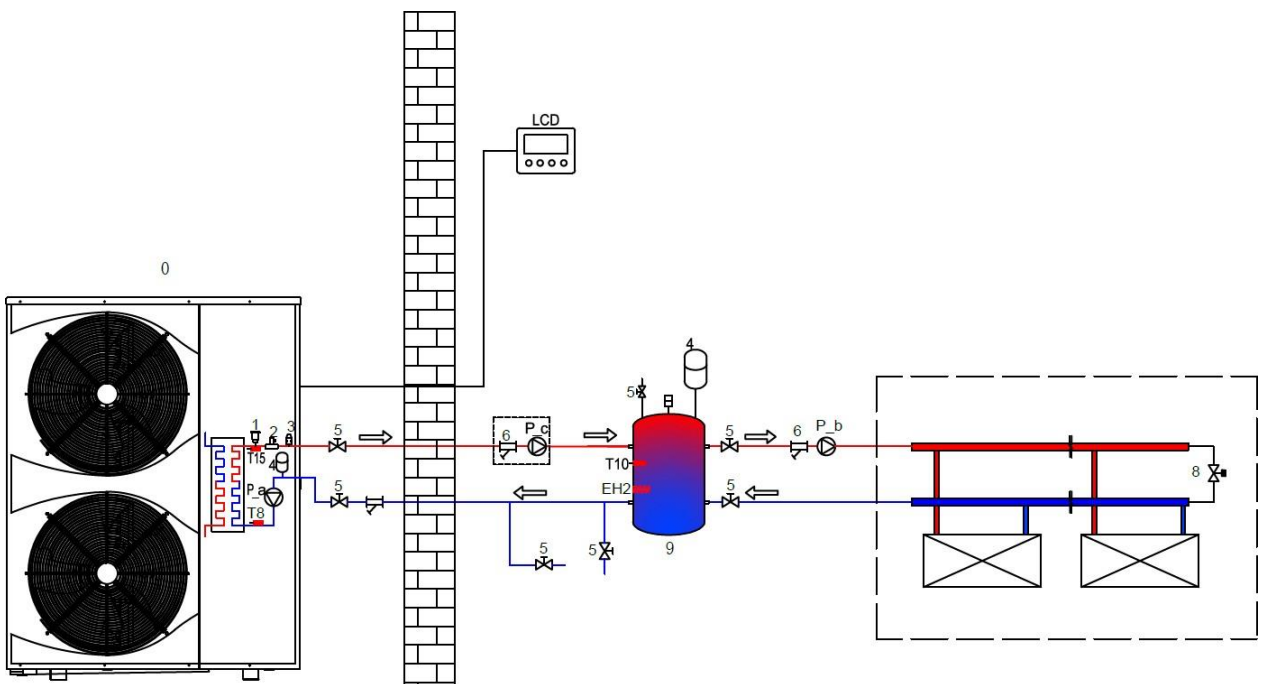

When the application scenario is floor heating, heating, and cooling mode

It is necessary to put the parameters P48=0 (disable the tank temperature sensor), L12=1 (disable high-temperature sterilization)

3.7.3 Schematic diagram of wiring in floor heating, heating and cooling modes

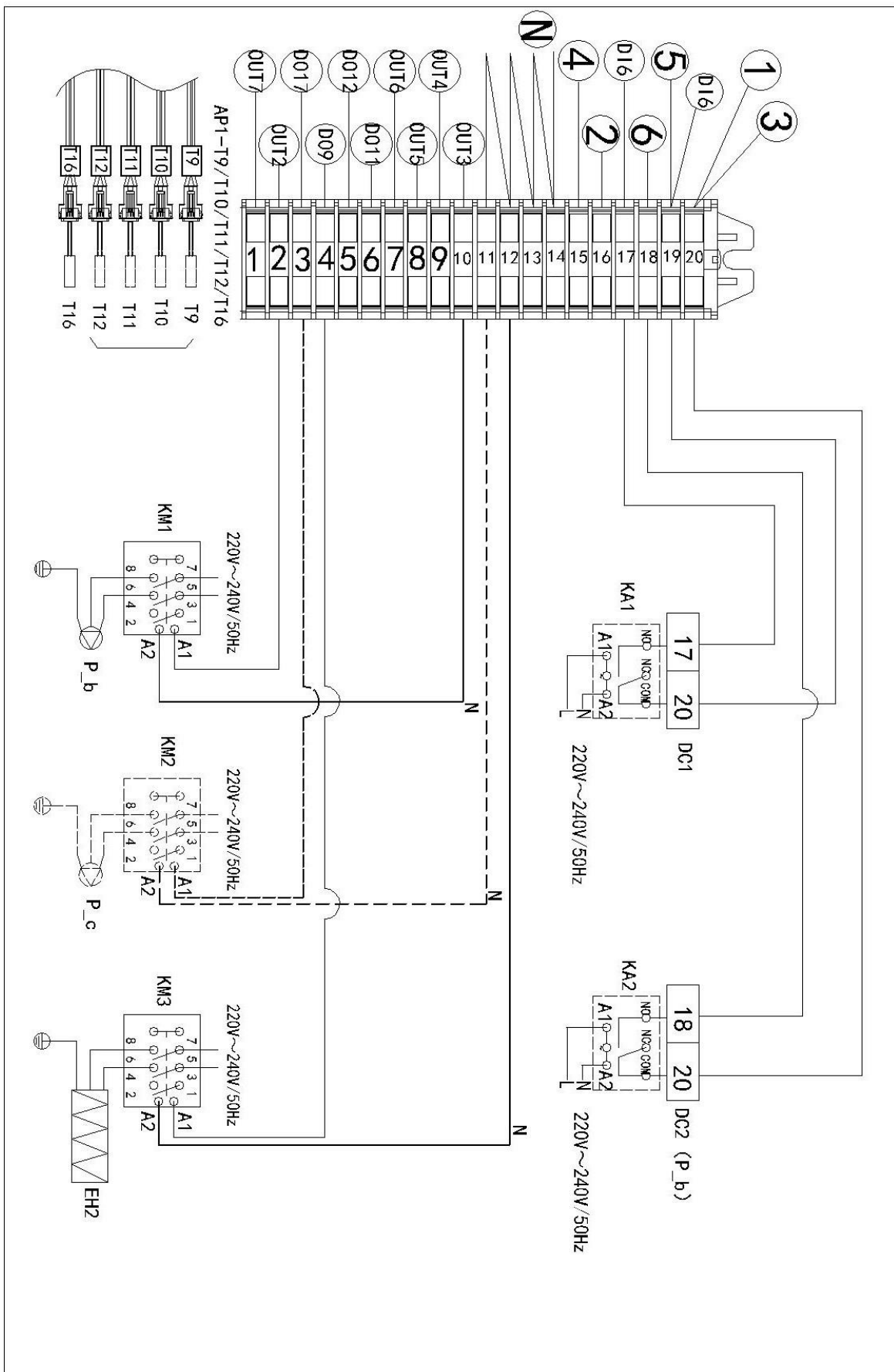

3.7.4 Installation diagram of hot water + cooling or hot water + heating mode waterwaysystem:

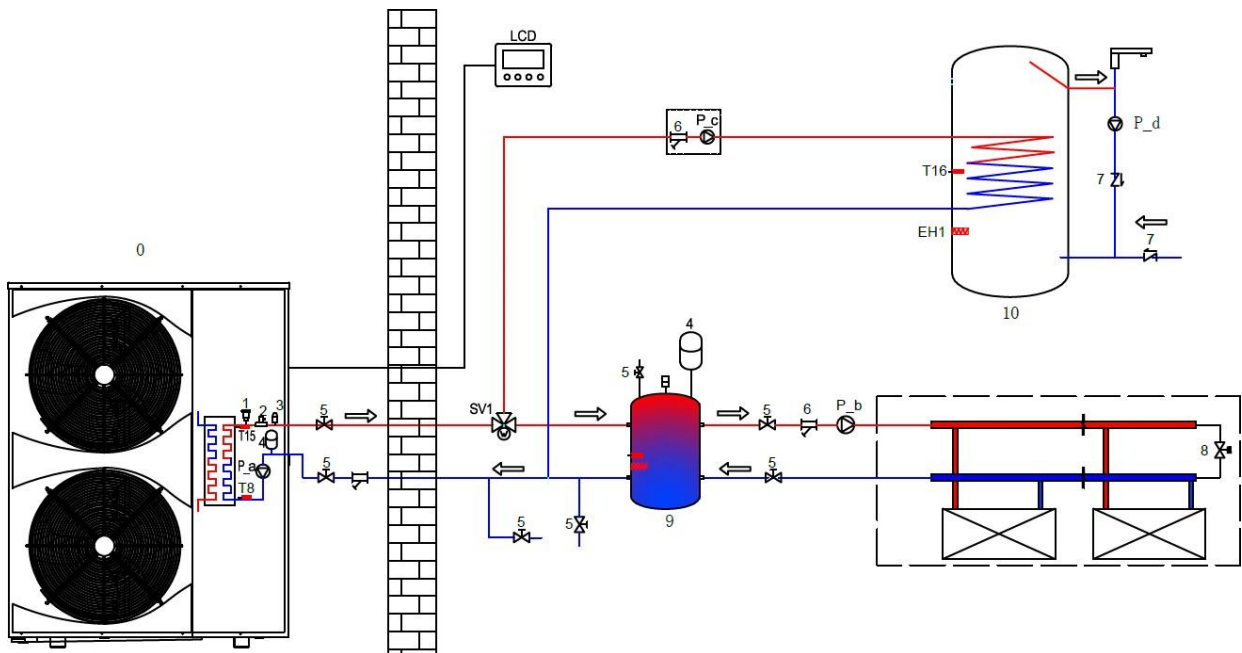

3.7.5 Installation diagram of hot water + floor heating mode waterway system

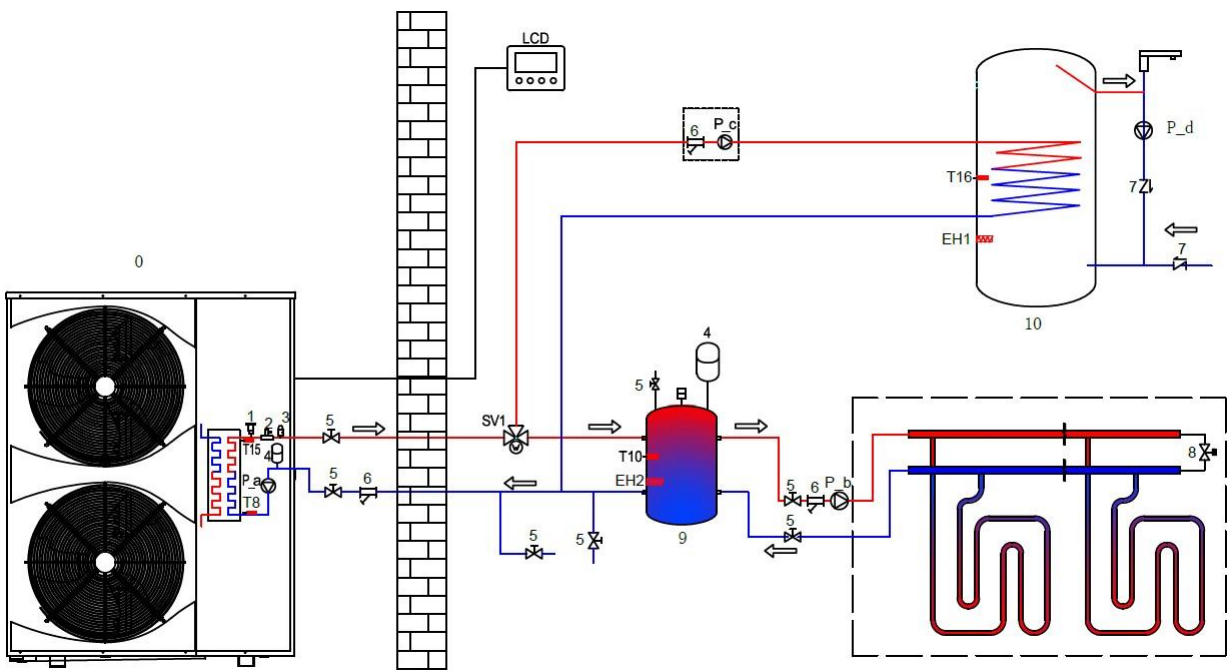

1. When the head of the DC pump of the P_a pump of the unit is not enough, an external auxiliary water pump is required to P_c, and the parameter P161 needs to be set to 0
2. When the parameter P150=2, the P_b pump controls the start and stop according to the heating secondary pump pump linkage switch;
When the parameter P150=3, the P_b water pump starts and stops according to the room temperature control.

3.7.6 Schematic diagram of hot water + refrigeration, hot water + heating, hot water +

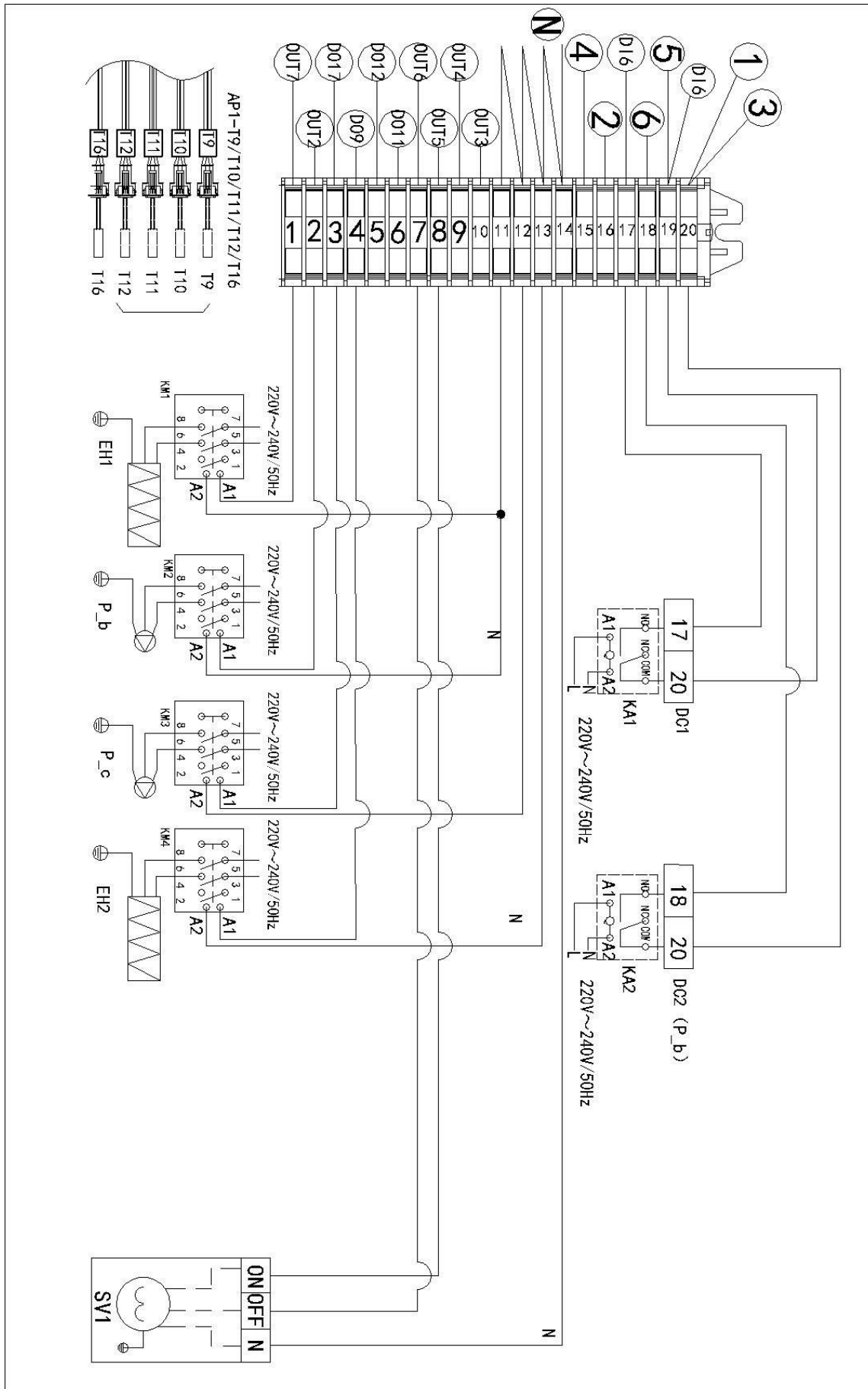

3.7.7 Installation diagram of a mixed-mode waterway system

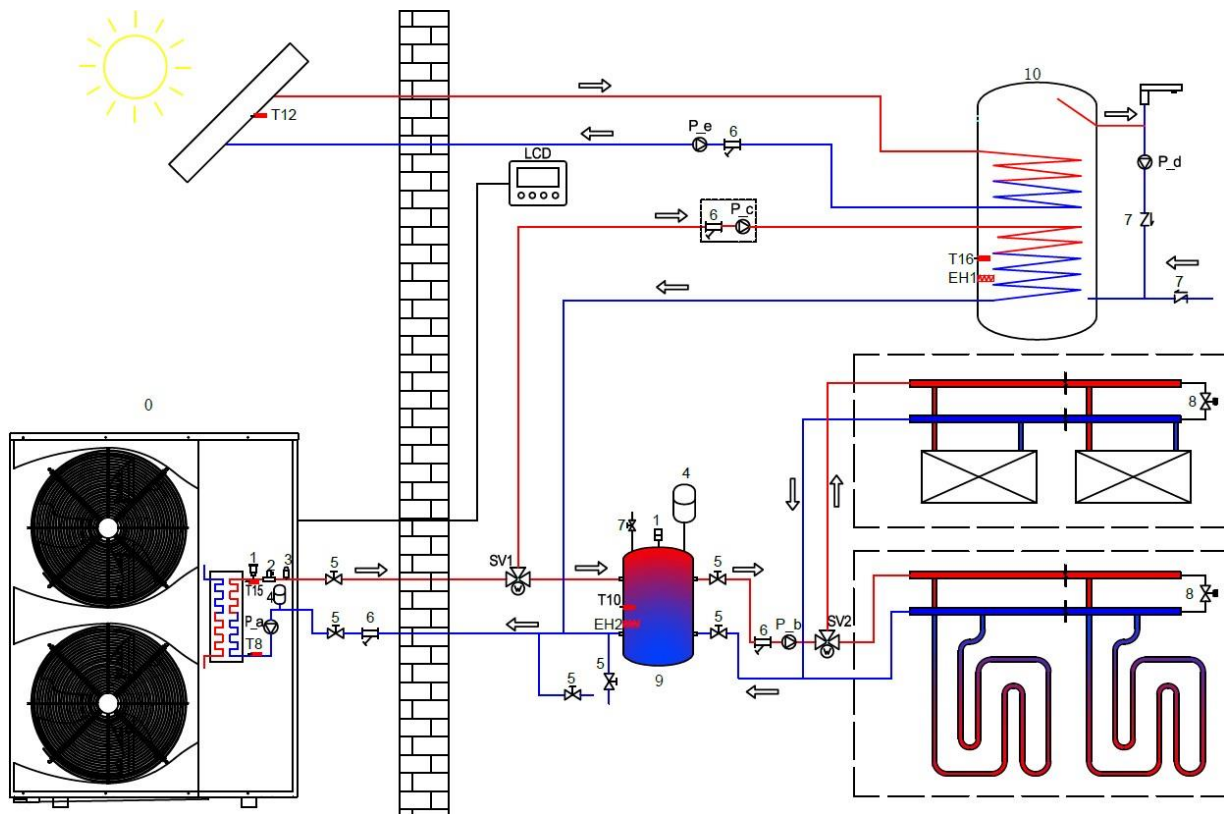

3.7.9 Schematic of cascade mode waterway installation

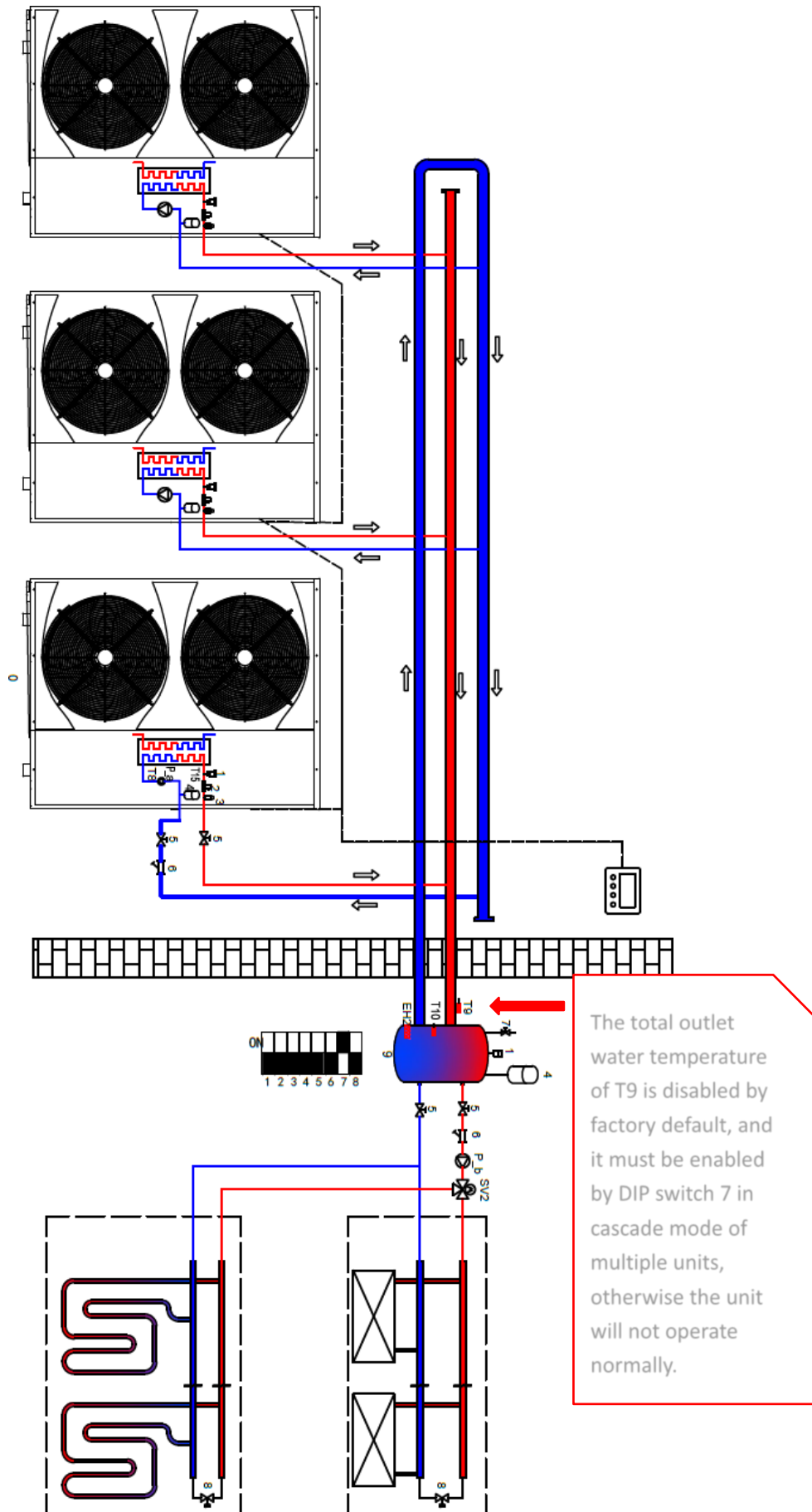

3.7.10 Schematic diagram of cascade mode waterway wiring

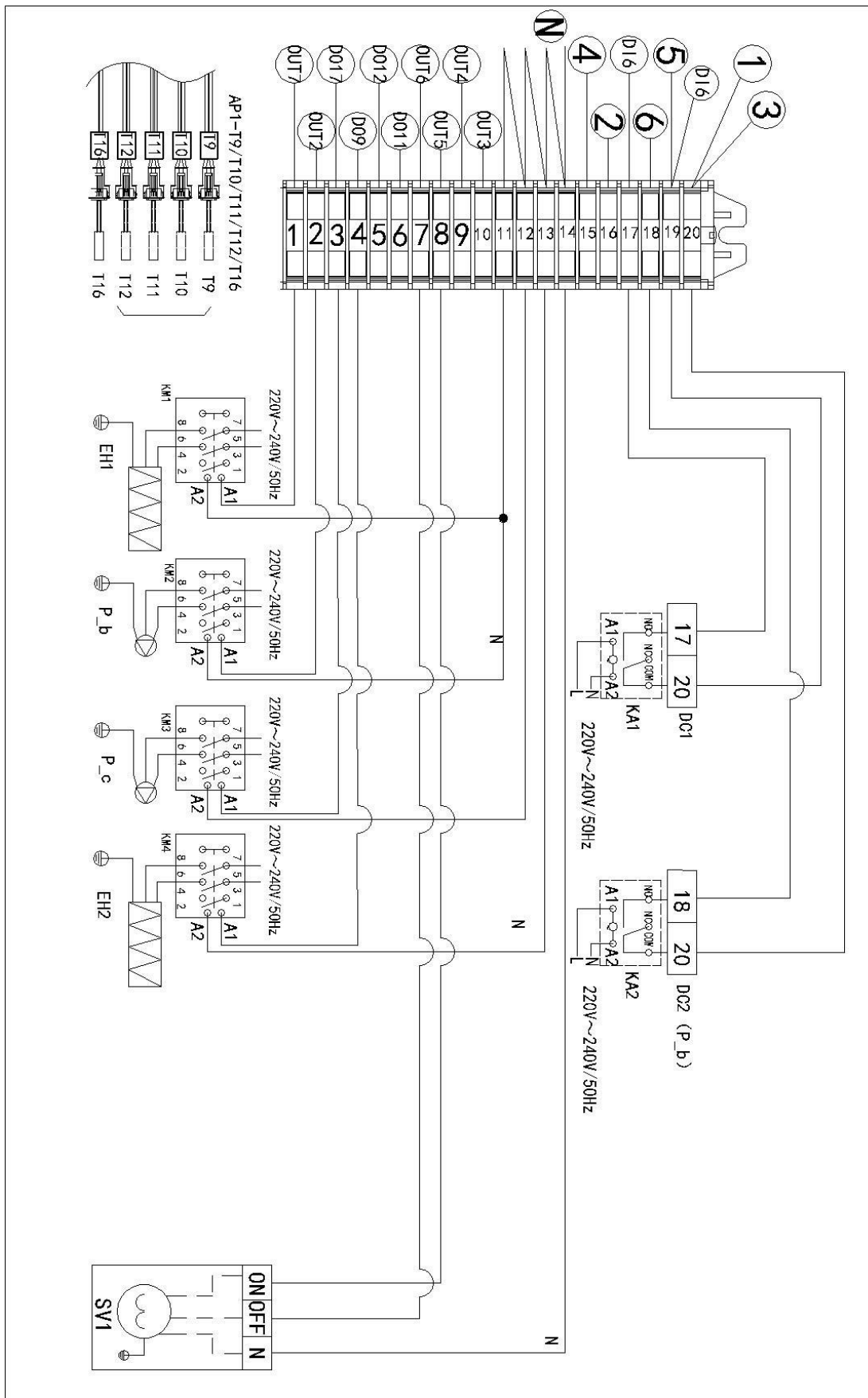

3.7.11 Floor heating + cooling + hot water + gas waterway installation schematic

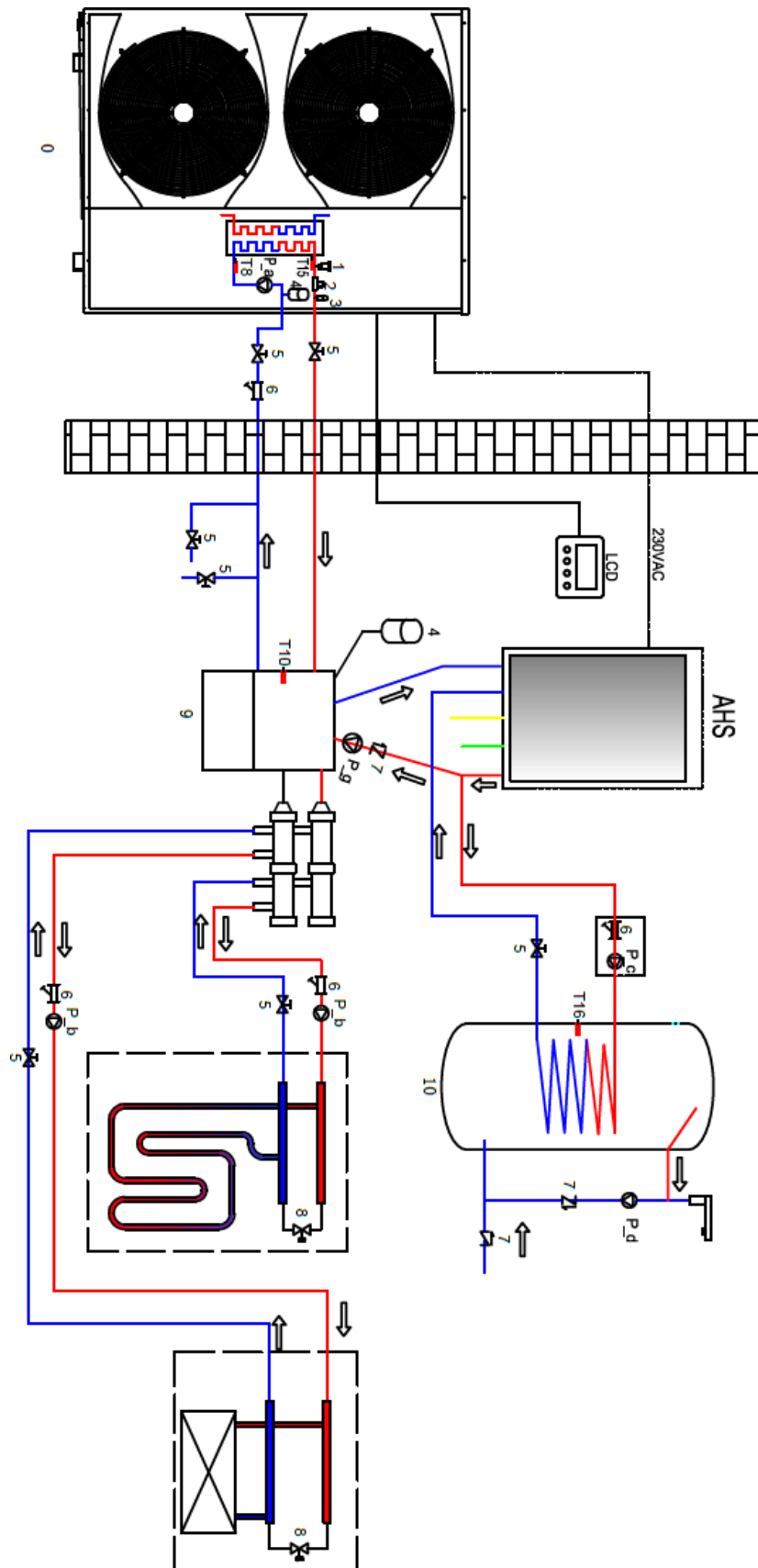

3.7.13 Three-way valve wiring method

Three-wire one-control three-way valve wiring method:

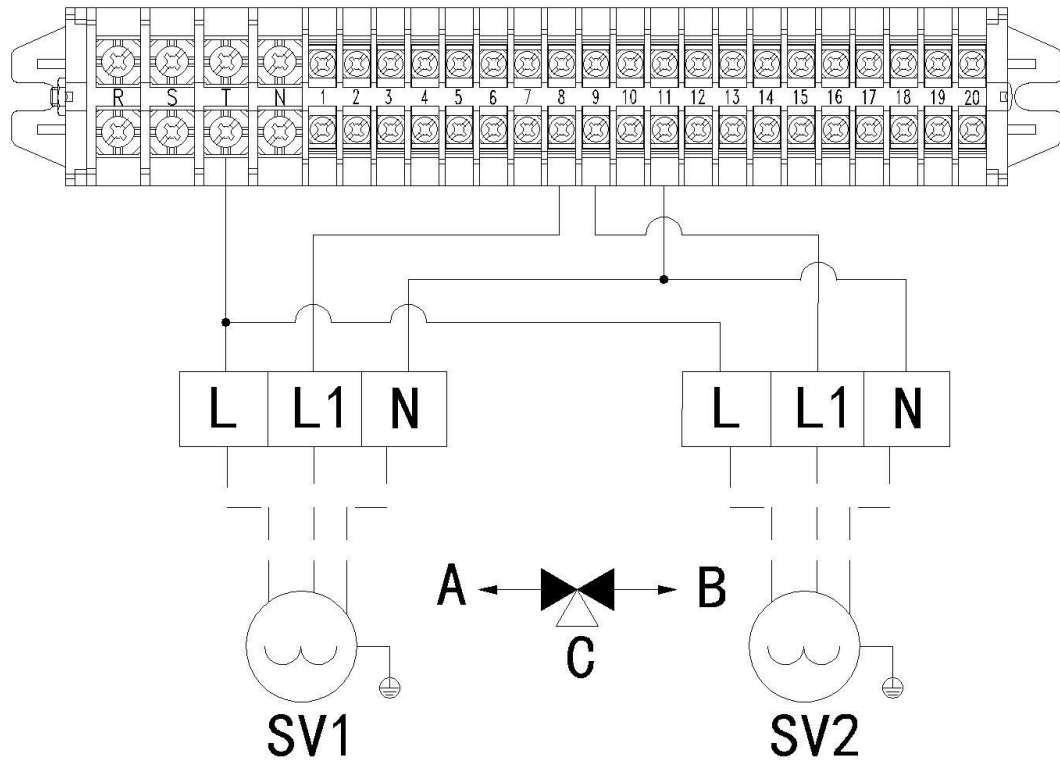

According to the above figure C as the input end, the output end is A and B, when the voltage (VAC230V) is only added to the L line, the valve maintains the initial position C-B, that is, the flow drops from C flows to the B position, and when the voltage is added to the L1 line, the valve drops to the C-A position, that is, the flow drops from C to the A position. When the voltage on the L1 line is removed, the valve drops back to the C-B position.

Three-wire two-control three-way valve wiring method:

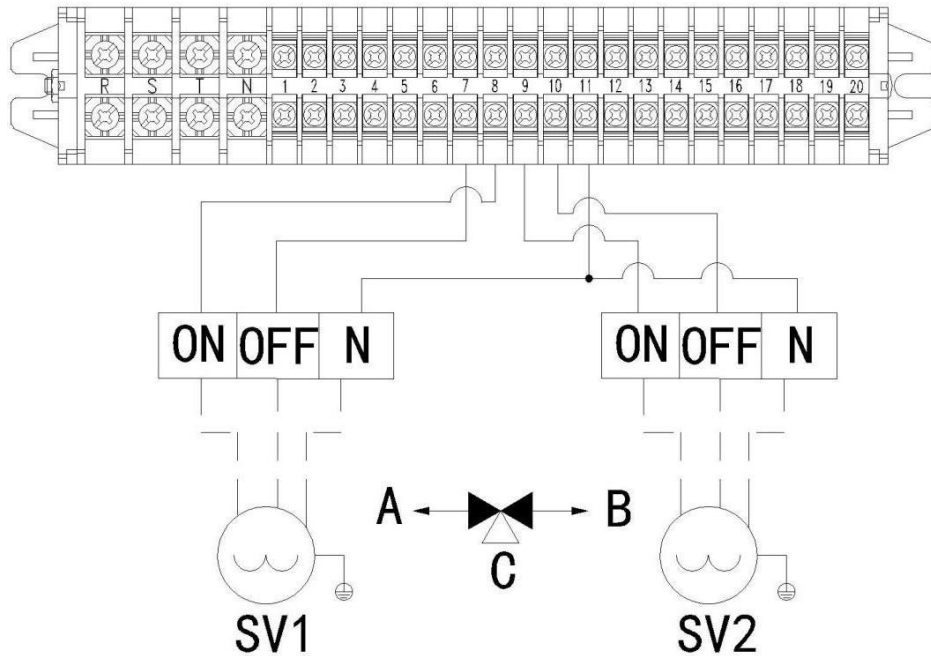

According to the above figure C as the input end, the output terminal is A and B, when the voltage (VAC230V) is added to the ON line, the valve maintains the initial position C-B, that is, the flow rate drops C flows to the B position, and when the voltage is added to the OFF line, the valve drops to the C-A position, that is, the flow drops from C to A Location.

SOL-010HC3/ SOL-014HC3/ SOL-018HC3/ SOL-024HC3Electrical schematic

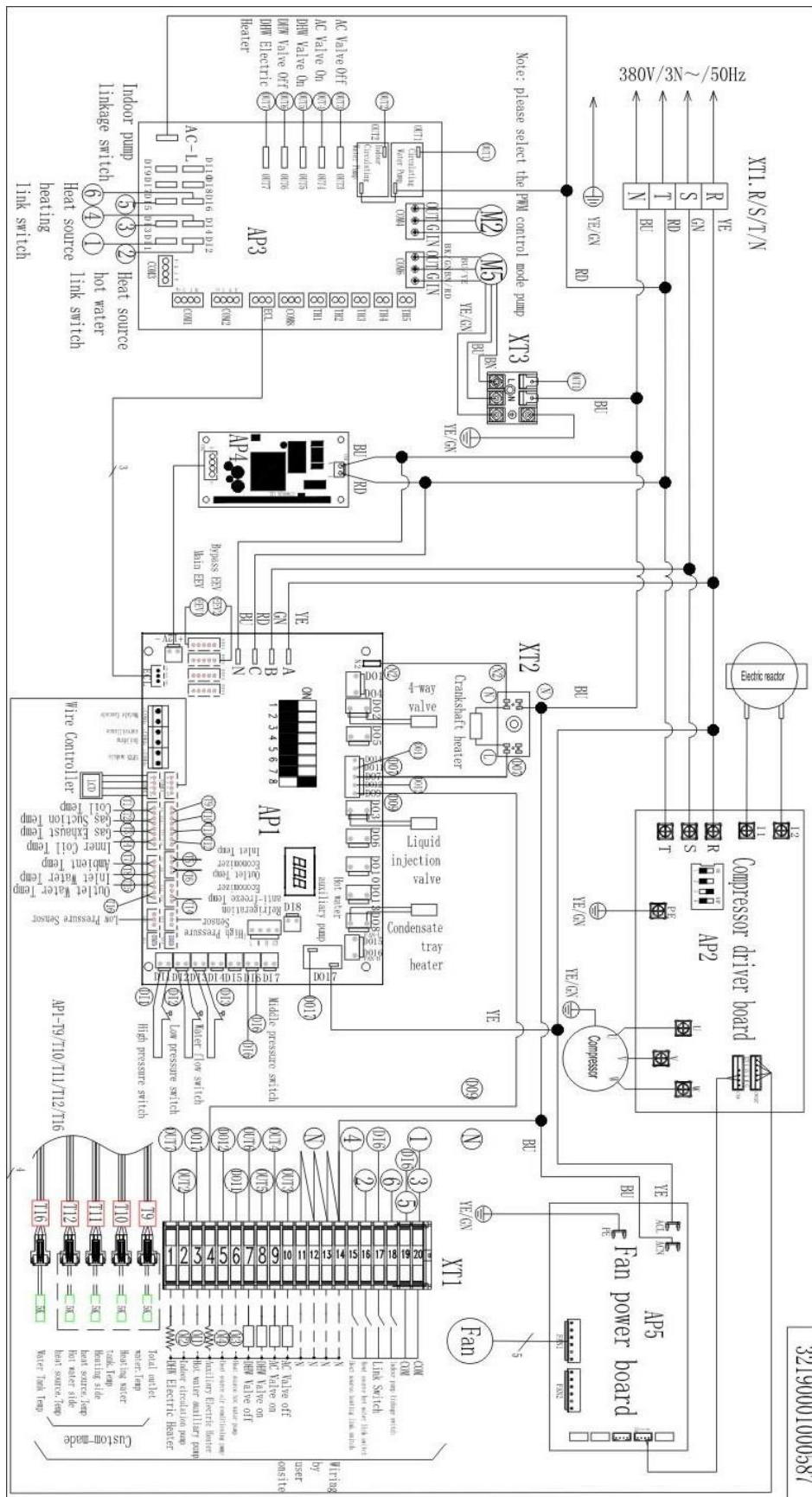



3.9 NCT Sensor resistance table



5K sensor resistance table													
temperatu re (°C)	Resistanc e (K Ω)	temperatu re (°C)	Resistanc e (K Ω)	temperatu re (°C)	Resistanc e (K Ω)	temperatu re (°C)	Resistanc e (K Ω)	temperatu re (°C)	Resistanc e (K Ω)	temperatu re (°C)	Resistanc e (K Ω)	temperatu re (°C)	Resistan ce (K Ω)
-40	108.4	-13	26.2913	14	7.7643	41	2.7692	68	1.1413	95	0.5196	122	0.2677
-39	102.3	-12	25.033	15	7.4506	42	2.6735	69	1.1008	96	0.5088	123	0.2615
-38	96.62	-11	23.8424	16	7.1813	43	2.5816	70	1.0734	97	0.4919	124	0.2554
-37	91.26	-10	22.7155	17	6.8658	44	2.4936	71	1.0412	98	0.4786	125	0.2496
-36	86.23	-9	21.6486	18	6.5934	45	2.4097	72	1.01	99	0.465	126	0.2438
-35	81.51	-8	20.638	19	6.3333	46	2.3276	73	0.98	100	0.4533	127	0.2383
-34	77.08	-7	19.6806	20	6.085	47	2.2491	74	0.9508	101	0.4418	128	0.2329
-33	72.92	-6	18.7732	21	5.8479	48	2.1739	75	0.9228	102	0.4385	129	0.2276
-32	69.01	-5	17.9129	22	5.6213	49	2.1016	76	0.8957	103	0.4273	130	0.2225
-31	65.33	-4	17.097	23	5.4048	50	2.0321	77	0.8695	104	0.4165	131	0.2175
-30	63.7306	-3	16.323	24	5.1978	51	1.9656	78	0.8441	105	0.406	132	0.2127
-29	60.3223	-2	15.5886	25	5	52	1.9016	79	0.8196	106	0.3958	133	0.2079
-28	57.118	-1	14.8713	26	4.8108	53	1.8399	80	0.7959	107	0.3859	134	0.2034
-27	54.1043	0	14.2293	27	4.6298	54	1.7804	81	0.773	108	0.3763	135	0.1989
-26	51.2686	1	13.6017	28	4.4586	55	1.7232	82	0.7508	109	0.367		
-25	48.5994	2	13.0057	29	4.2909	56	1.668	83	0.7295	110	0.3579		
-24	46.086	3	12.439	30	4.1323	57	1.614	84	0.7086	111	0.3491		
-23	43.7182	4	11.9011	31	3.9804	58	1.5636	85	0.6885	112	0.3406		
-22	41.4868	5	11.3894	32	3.8349	59	1.5142	86	0.669	113	0.3323		
-21	39.3833	6	10.9028	33	3.6955	60	1.4856	87	0.6502	114	0.3243		
-20	37.3992	7	10.4399	34	3.562	61	1.4206	88	0.632	115	0.3165		
-19	35.5274	8	9.9995	35	3.434	62	1.3763	89	0.6144	116	0.3089		
-18	33.7607	9	9.5802	36	3.3119	63	1.3336	90	0.5973	117	0.3015		
-17	32.0927	10	9.181	37	3.1937	64	1.2923	91	0.5808	118	0.2944		
-16	30.5172	11	8.8008	38	3.0809	65	1.2526	92	0.5647	119	0.2874		
-15	29.0286	12	8.4395	39	2.9727	66	1.2142	93	0.5492	120	0.2807		
-14	27.6216	13	8.0934	40	2.8688	67	1.1771	94	0.5342	121	0.2741		

50K sensor resistance table													
Temperature (°C).	Resistance (°C)	Temperature (°C).	Resistance (°C)	Temperature (°C).	Resistance (°C)	Temperature (°C).	Resistance (°C)	Temperature (°C).	Resistance (°C)	Temperature (°C).	Resistance (°C)	Temperature (°C).	Resistance (°C)
-40	1588	-12	306.29	16	75.001	44	22.648	72	8.0903	100	3.312	128	1.5165
-39	1489	-11	290.06	17	71.625	45	21.773	73	7.8193	101	3.215	129	1.4774
-38	1396	-10	274.78	18	68.416	46	20.935	74	7.5586	102	3.1214	130	1.4396
-37	1310	-9	260.4	19	65.368	47	20.134	75	7.3077	103	3.031	131	1.4028
-36	1230	-8	246.85	20	62.474	48	19.368	76	7.0667	104	2.9435	132	1.3672
-35	1156	-7	234.08	21	59.719	49	18.635	77	6.8345	105	2.8589	133	1.3327
-34	1086	-6	222.02	22	57.104	50	17.932	78	6.6109	106	2.7772	134	1.2991
-33	1021	-5	210.69	23	54.62	51	17.26	79	6.396	107	2.6982	135	1.2665
-32	959.9	-4	199.98	24	52.253	52	16.616	80	6.189	108	2.6218	136	1.2349
-31	903.1	-3	189.86	25	50	53	16.001	81	5.9894	109	2.5479	137	1.2042
-30	866.96	-2	180.34	26	47.857	54	15.41	82	5.7976	110	2.4764	138	1.1744
-29	815.7	-1	171.33	27	45.817	55	14.844	83	5.6126	111	2.4072	139	1.1455
-28	767.71	0	162.81	28	43.877	56	14.302	84	5.4346	112	2.3403	140	1.1174
-27	722.87	1	154.78	29	42.027	57	13.782	85	5.2629	113	2.2755	141	1.0901
-26	680.87	2	147.19	30	40.265	58	13.284	86	5.0974	114	2.2128	142	1.0636
-25	641.59	3	140	31	38.585	59	12.807	87	4.9379	115	2.1522	143	1.0379
-24	604.82	4	133.21	32	36.987	60	12.348	88	4.7842	116	2.0934	144	1.0128
-23	570.34	5	126.79	33	35.462	61	11.909	89	4.6359	117	2.0365	145	0.9886
-22	538.03	6	120.72	34	34.007	62	11.487	90	4.4931	118	1.9814	146	0.9649
-21	507.74	7	114.96	35	32.619	63	11.083	91	4.3552	119	1.928	147	0.942
-20	479.34	8	109.51	36	31.297	64	10.694	92	4.2222	120	1.8764	148	0.9197
-19	452.68	9	104.34	37	30.034	65	10.321	93	4.0939	121	1.8263	149	0.898
-18	427.67	10	99.456	38	28.827	66	9.9628	94	3.97	122	1.7778	150	0.8769
-17	404.17	11	94.826	39	27.677	67	9.6187	95	3.8506	123	1.7308		
-16	382.11	12	90.426	40	26.578	68	9.2882	96	3.7351	124	1.6852		
-15	361.35	13	86.262	41	25.528	69	8.9706	97	3.6238	125	1.6411		
-14	341.86	14	82.312	42	24.524	70	8.6655	98	3.5162	126	1.5983		
-13	323.53	15	78.561	43	23.566	71	8.3723	99	3.4123	127	1.5567		

Chapter 4: Fault diagnosis and treatment

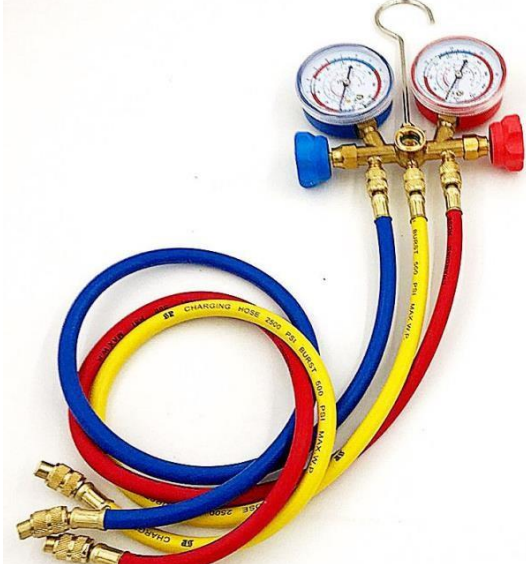

4.1 Repair use tools

serial number	Tool name	Image	function
1	Phillips screwdriver (6 inches).		Remove the Phillips screws
2	Slotted screwdriver (6 inches).		Remove the flat line screws
3	Active wrench (6 inches).		Removing screws, etc
4	Sharp-nosed pliers (6 inches).		Wire cutting, terminal removal, etc
5	Hex wrench (size 5).		Open shut-off valve, etc
6	Electric screwdriver		Remove screws, etc



<p>7</p>	<p>Clamp multimeter</p>		<p>Measure current, voltage, resistance, capacitance, etc</p>
<p>8</p>	<p>vacuum pump</p>		<p>Fluorine system vacuuming</p>
<p>9</p>	<p>Double head pressure gauge</p>		<p>Fluorine system pressure, vacuuming, etc</p>

Note: Other special tools are not listed, the above tools can ensure basic maintenance inspection, etc.

4.2 Model disassembly and parts

Serial number	Image	Illustrate
1		<p>Front trim panel removal method:</p> <p>unscrew the 7 screws on the front panel; Use a "+" screwdriver or an electric cross tool</p>
2		<p>Remove the front trim panel to remove the top cover</p>

3		<p>How to open the top cover:</p> <p>The top cover fixed part, all screws must be removed. Use a Phillips screwdriver or electric Phillips tool.</p>
---	--	--



4		Open the top cover upwards
5	 	<p>Right panel removal:</p> <p>After the top cover is removed, you only need to remove the two fixing screws under the right plate to remove the right plate by pressing down. Use a "+" screwdriver or electric cross tool;</p>

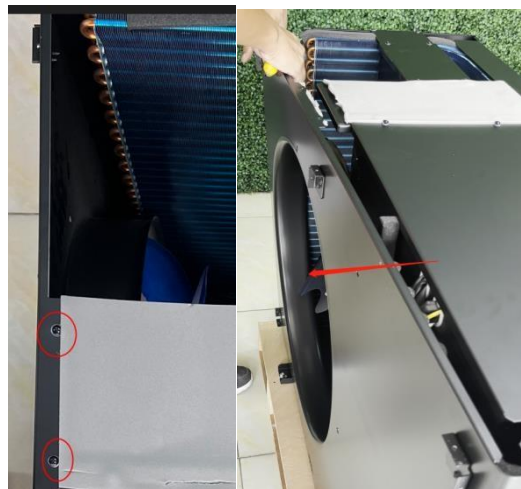
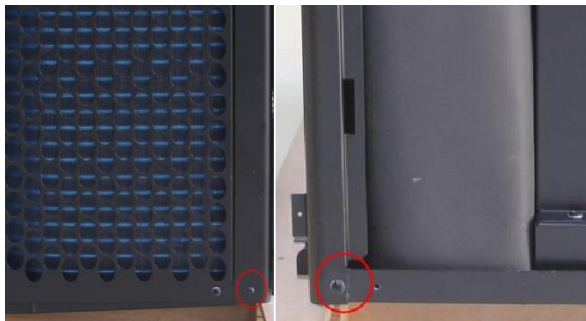

6

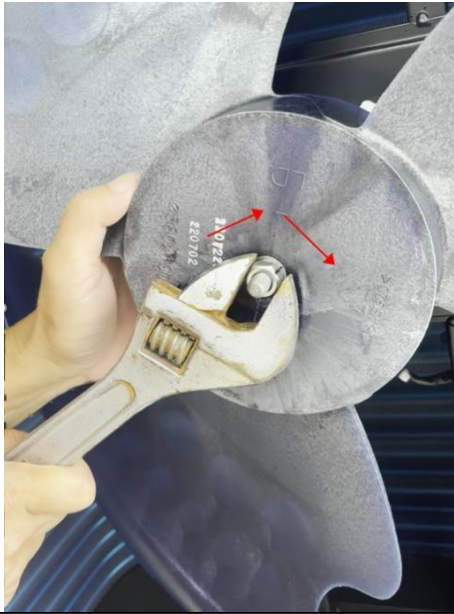

Front panel
removal:

Remove the 7 screws
on the front and 2
screws on the fan
fixing plate and the
left and right-side
screws;
Use a "+"
screwdriver or an
electric cross tool;

<p>7</p>		<p>Blade removal: Use the movable wrench to secure the nut and turn the wrench clockwise Use an active wrench</p>
<p>8</p>		<p>Motor removal: 4 fixing screws Use a "+" screwdriver or an electric cross tool;</p>
<p>9</p>		<p>Removal of the rear decorative panel: Unscrew the decorative version 7 screws Use a "+" screwdriver or an electric cross tool;</p>

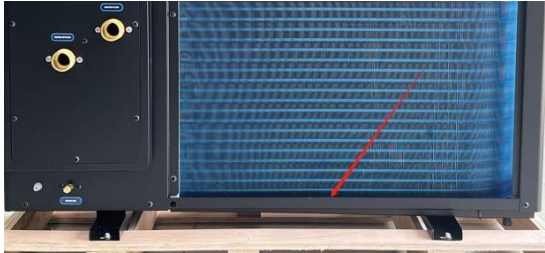
<p>10</p>		<p>Backplane removal: Remove the drain buckle, remove the back plate, remove the fixing screws; Use a "+" screwdriver or an electric cross tool;</p>
<p>11</p>		<p>Appliance box top cover removal: Unscrew the 4 screws on the cover Use a "+" screwdriver or electric cross tool;</p>
<p>12</p>		<p>15kW Fan power board: Unscrew the 4 screws on the fan power strip Use a "+" screwdriver or an electric cross tool;</p>
<p>13</p>		<p>15kW Chassis electric heating removal: Chassis electric heating D08 Use needle-nose pliers</p>

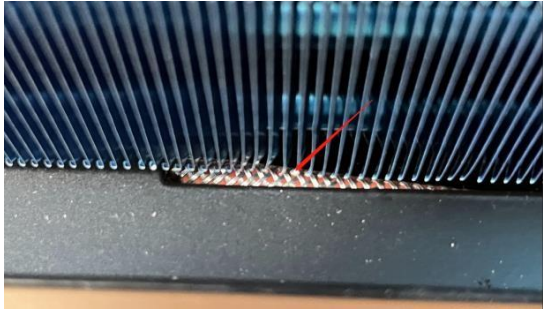
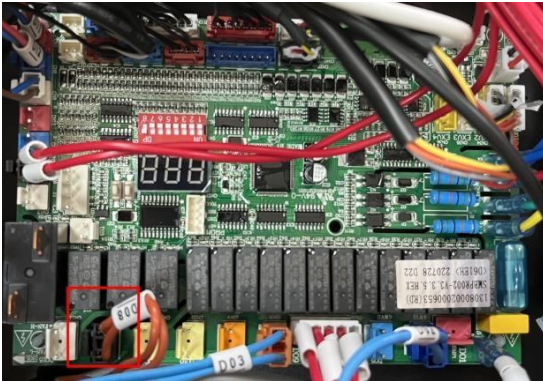
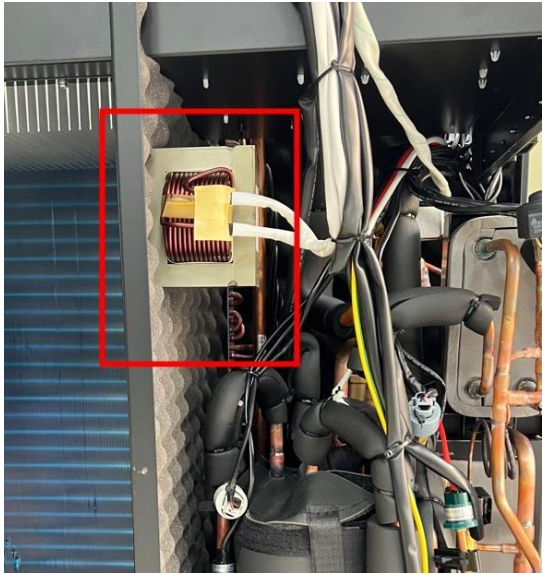
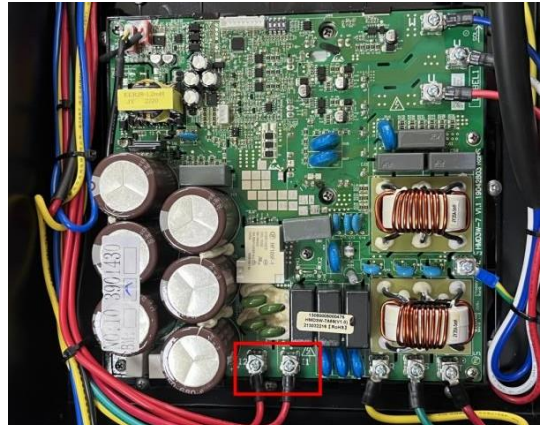
	 	
<p>14</p>	 	<p>Reactor removal:</p> <p>Reactor I2 I1</p> <p>Use a "+" screwdriver or an electric cross tool;</p>

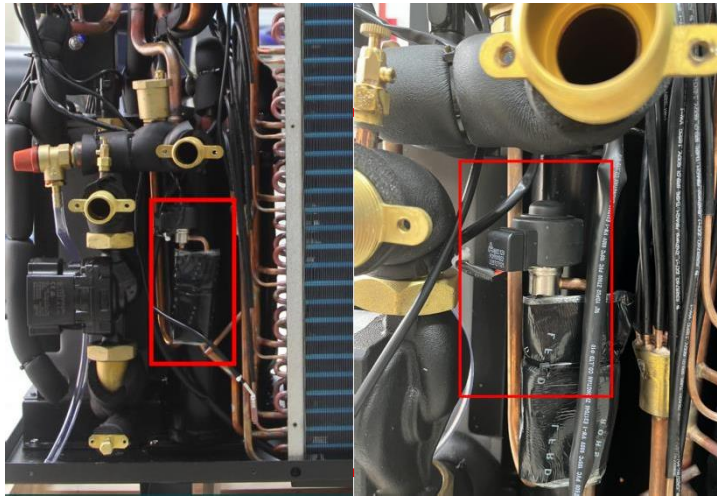
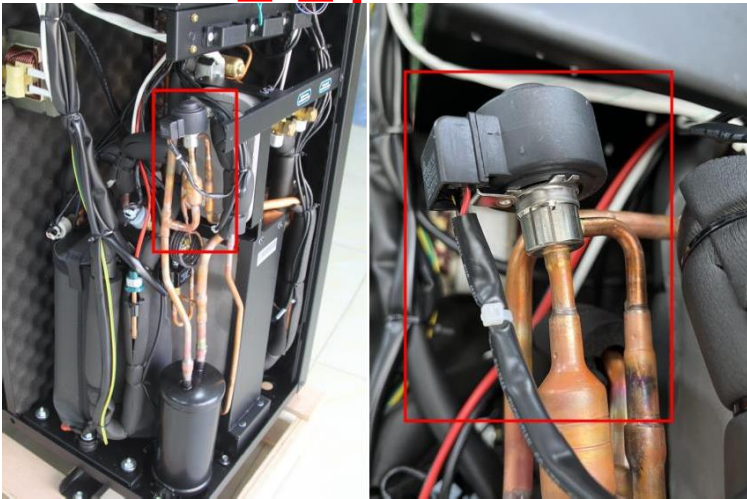
<p>15</p>		<p>15kW Main electronic expansion valve removal:</p> <p>Main electronic expansion valve EXV1</p>
<p>16</p>		<p>15kW Auxiliary electronic expansion valve removal:</p> <p>Auxiliary electronic expansion valve EXV2</p>

<p>17</p>		<p>15kW Fans</p>
<p>18</p>		<p>High pressure sensor A14 (red).</p>

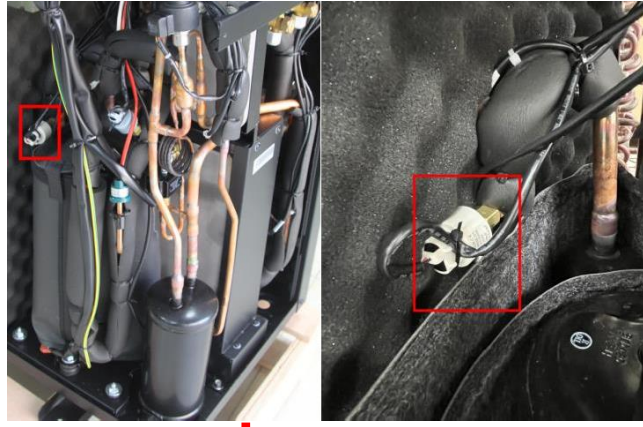
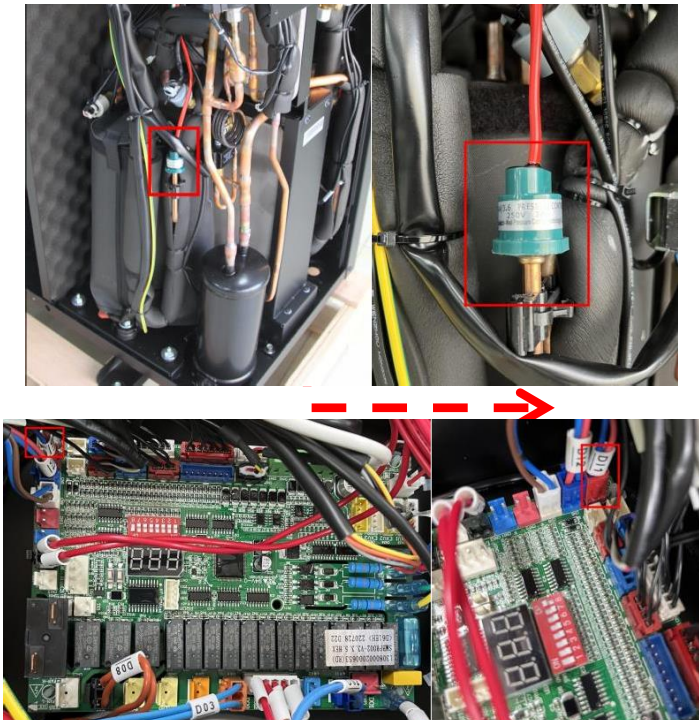
<p>19</p>		<p>15kW low voltage sensor Low voltage sensor A13 (blue)</p>
<p>20</p>		<p>15kW high voltage switch High-voltage switch D11</p>

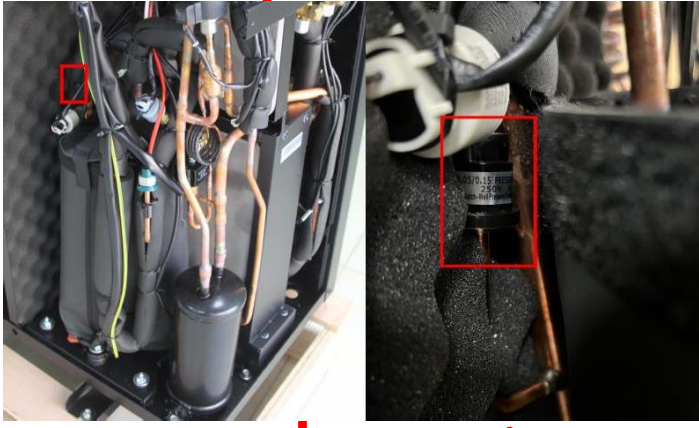
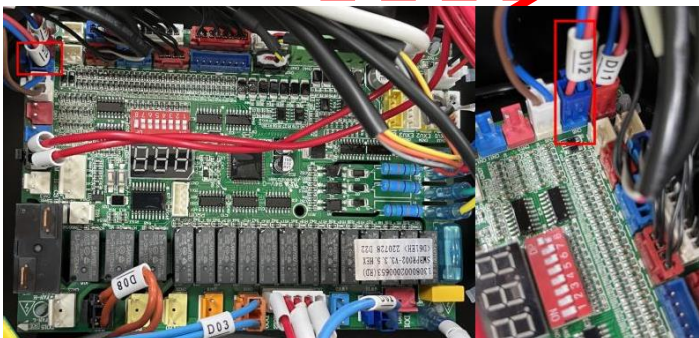
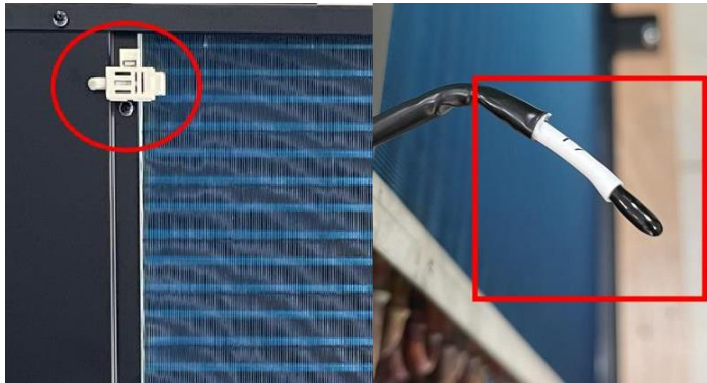
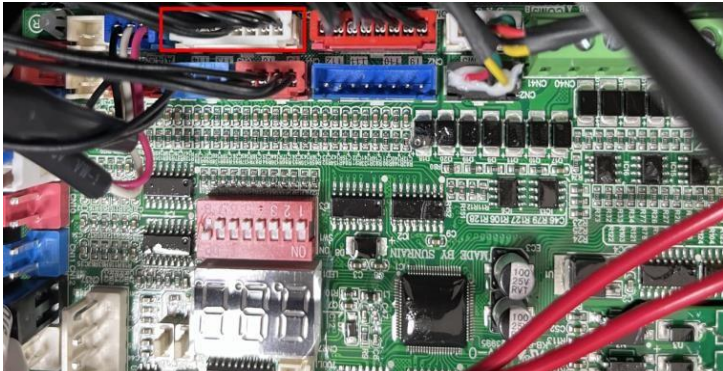

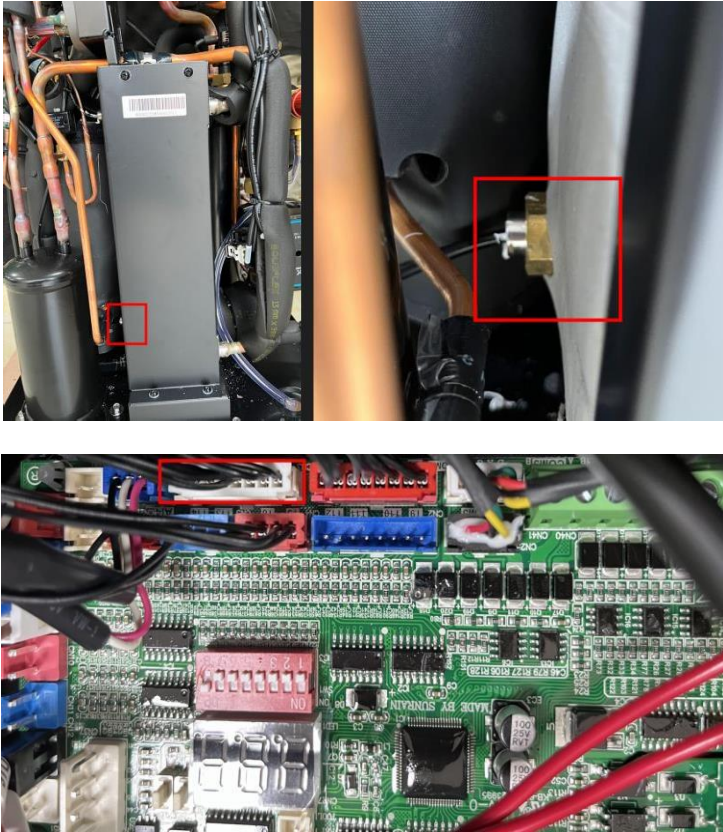
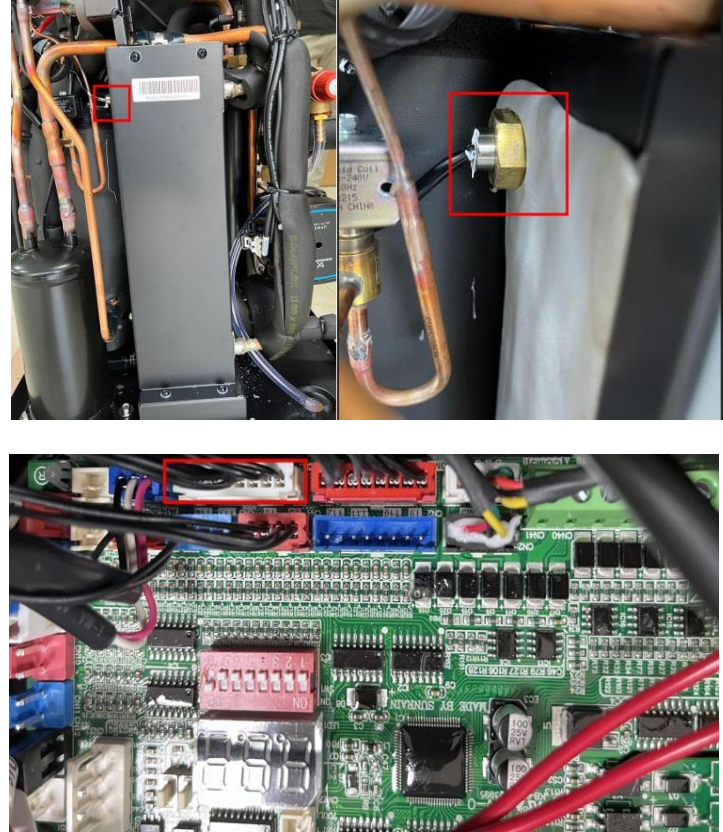
<p>21</p>	 	<p>15kW low voltage switch Low voltage switch D12</p>
<p>22</p>	 	<p>15kW ambient temperature sensor: Ambient temperature sensorT7 5K</p>

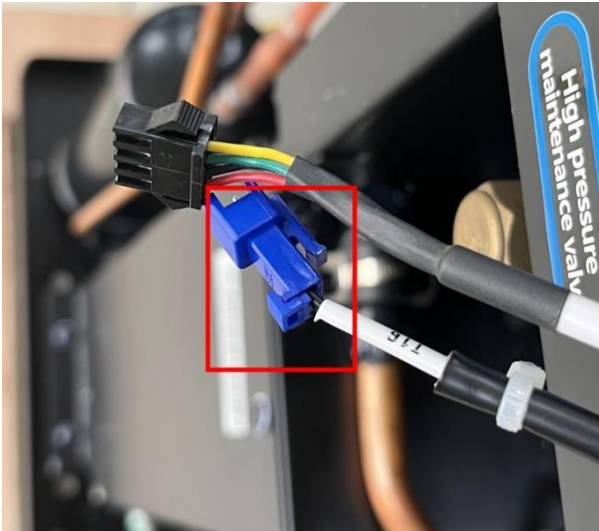
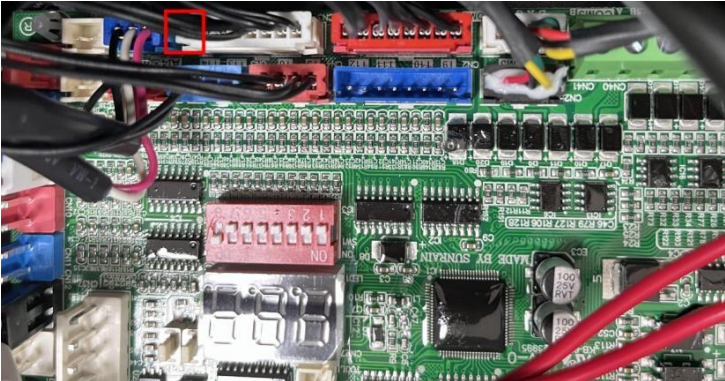
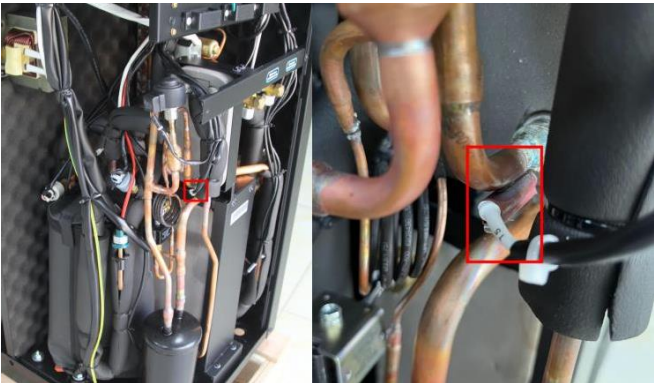
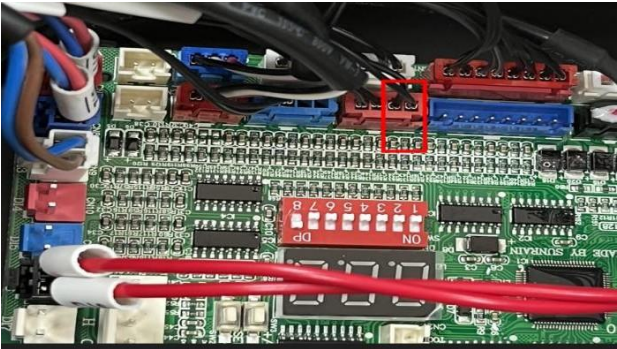
<p>23</p>		<p>15kW inlet water temperature sensor: Inlet water temperature sensorT8 5K</p>
<p>24</p>		<p>15kW effluent temperature sensor: Outlet water temperature sensor T15 5K</p>

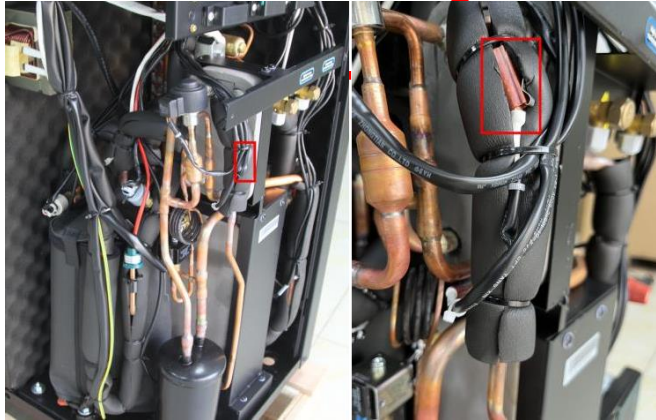
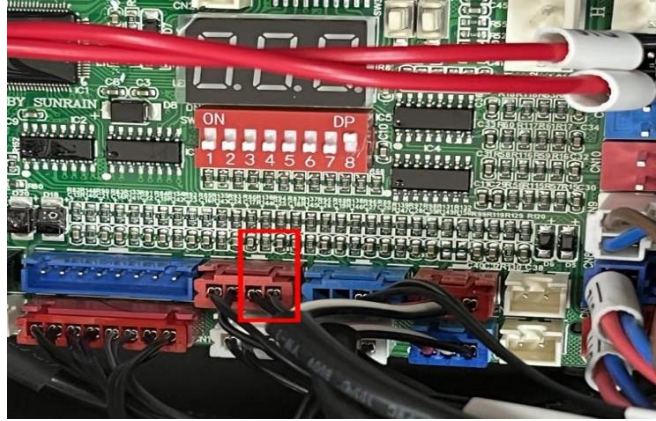
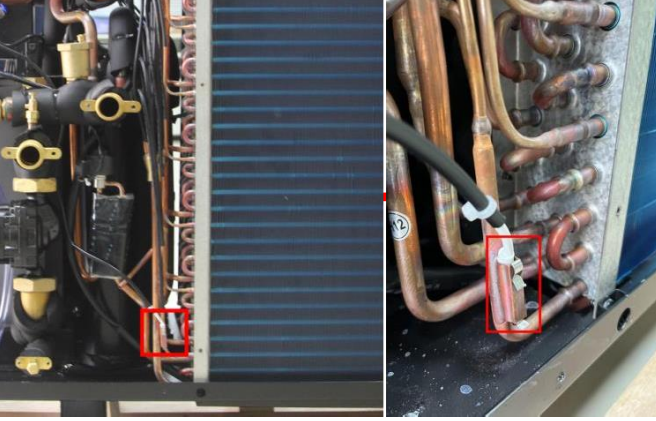
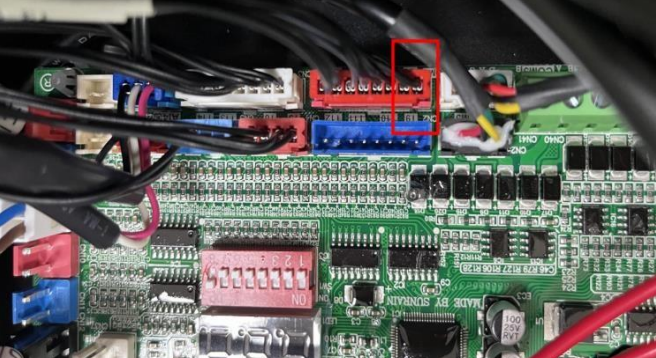
<p>25</p>	 	<p>15kW water tank temperature sensor: 15kW tank temperature sensor T16 5K</p>
<p>26</p>	 	<p>15kW economical inlet temperature sensor 15kW economical inlet temperature sensor T5 5K</p>

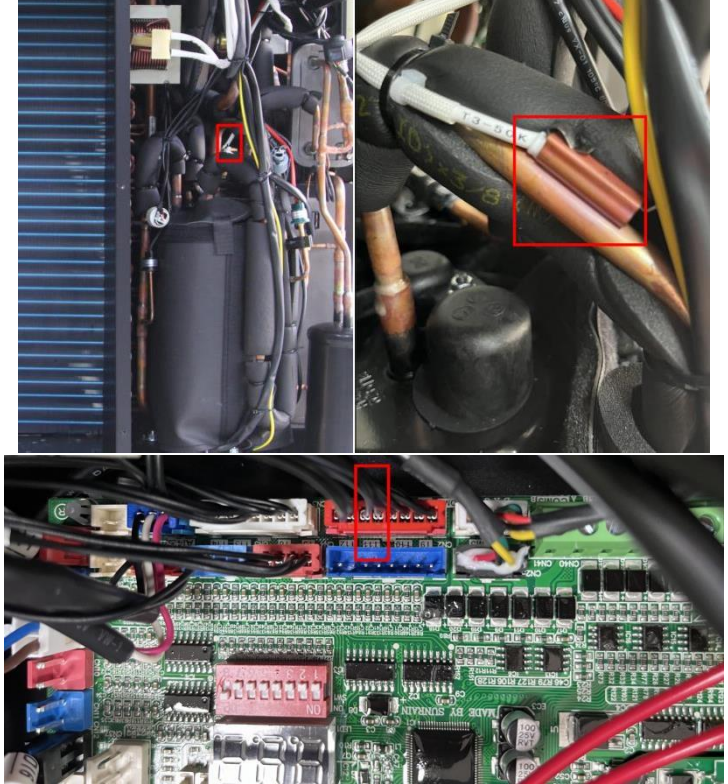
<p>27</p>	 	<p>15kW economical temperature sensor: Economical temperature sensorT6 5K</p>
<p>28</p>	 	<p>15kW coil temperature sensor Coil temperature sensor T2</p>

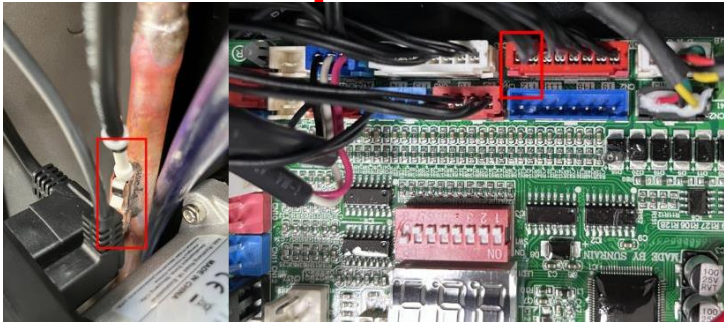
<p>29</p>		<p>15kW return air temperature sensor Return air temperature sensorT2 5K</p>
<p>30</p>		<p>15kW exhaust gas temperature sensor Exhaust gas temperature sensor 50K</p>

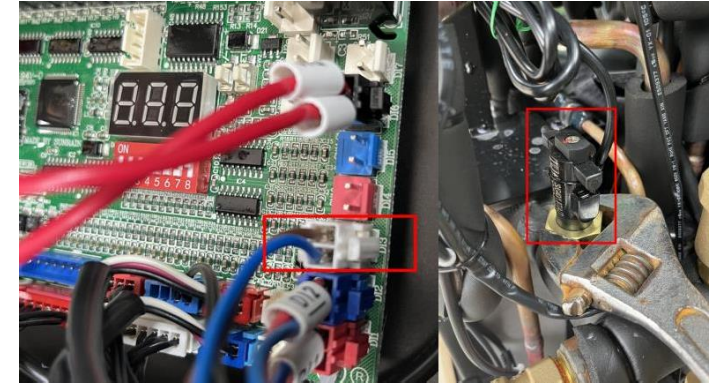
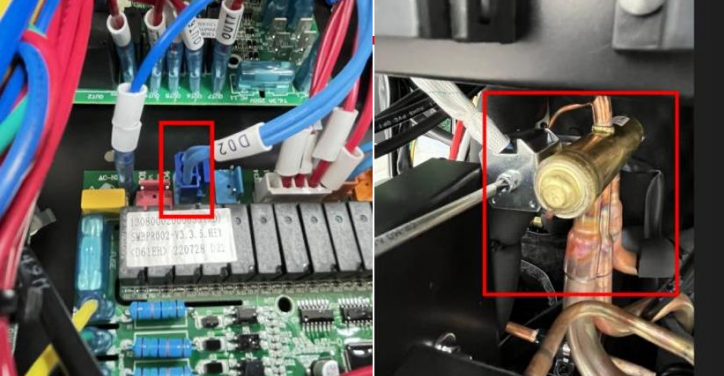
<p>31</p>		<p>15kW internal disc temperature sensor Internal disk temperature sensorT4 5K</p>
<p>32</p>		<p>15kW wire controller</p>
<p>33</p>		<p>15kW water flow switch Water flow switch D13</p>
<p>34</p>		<p>15kW 4-way valve4-way valve D02</p>

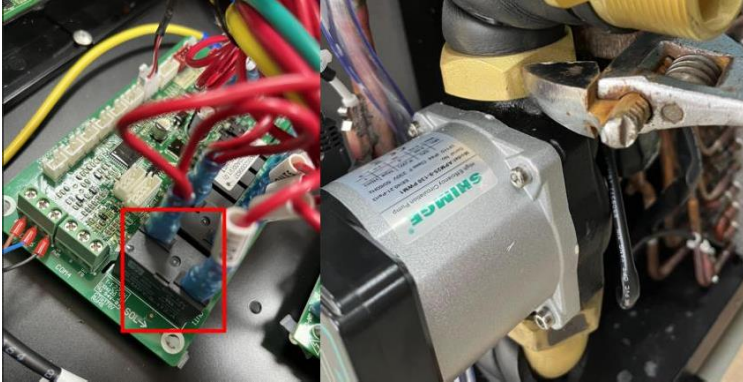
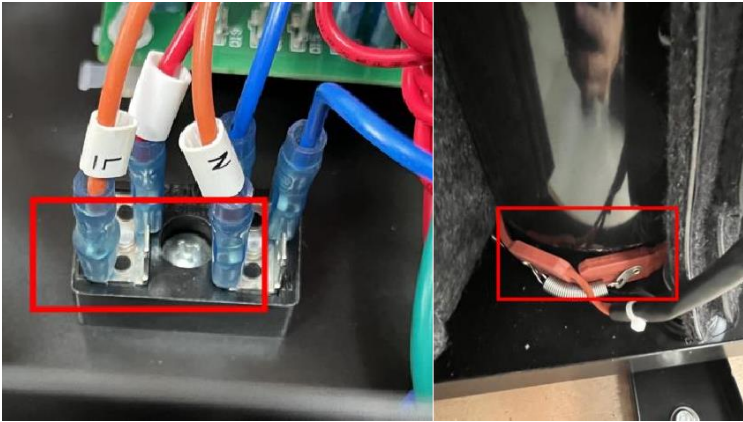
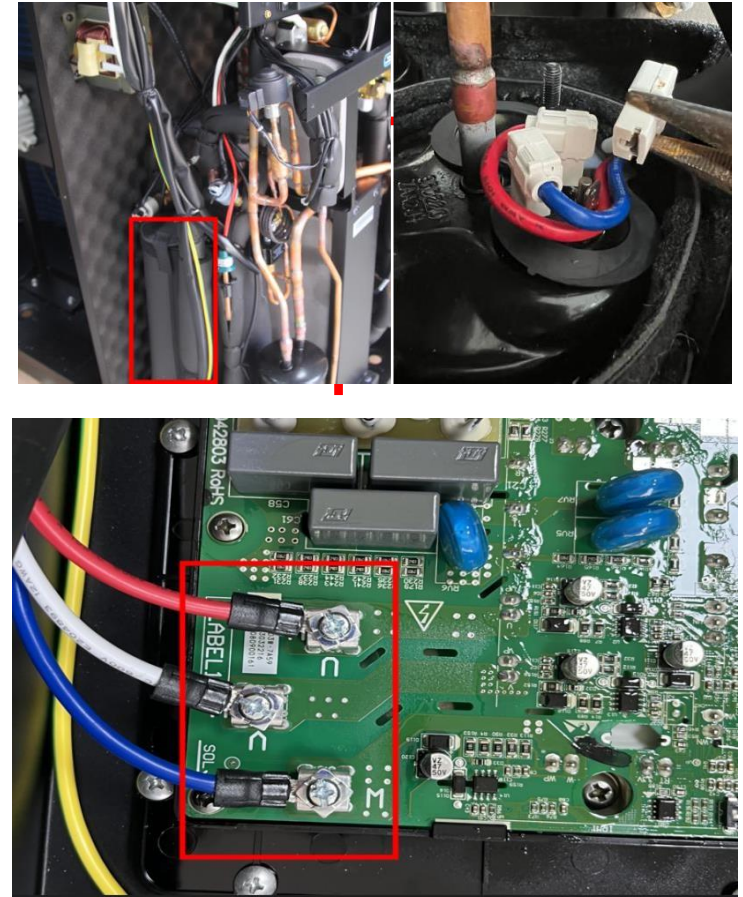
<p>35</p>		<p>15kw circulating water pump Circulating water pump OUT1</p>
<p>36</p>		<p>Compressor tracing</p>
<p>37</p>		<p>15kw compressor</p>

4.3 Common troubleshooting and repair

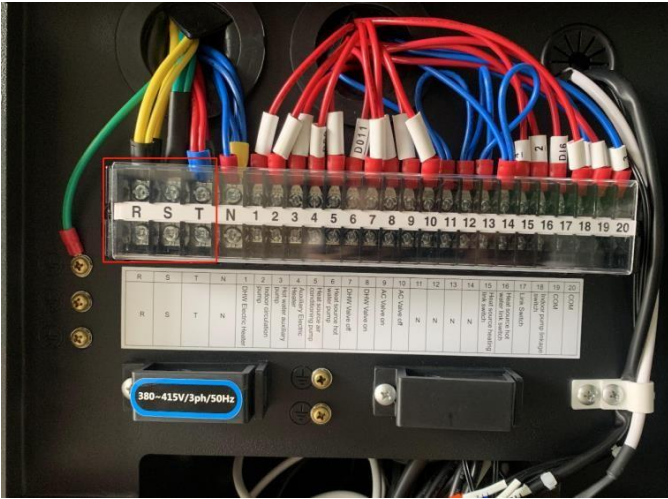
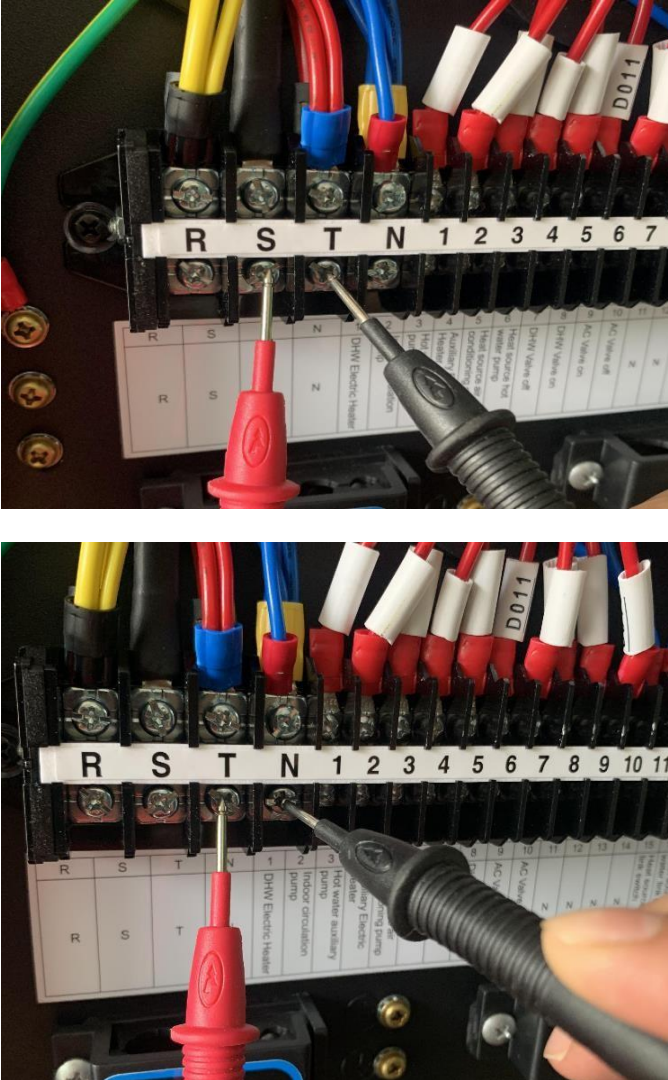
<p>E01 Out-of-phase protection</p>		<p>Repair method:</p> <ol style="list-style-type: none"> 1. S、T Swap two of the threelive wires at will (after swapping,it will be powered back on) 220v machines do not experience this failure
<p>E02 Phase loss fault</p>		<p>Repair method:</p> <p>Step 1: Check that the power cord connection is securely secured</p> <p>Step 2: Use a multimeter to measure the presence of 220V between the neutral line and each live wire (measurement requires energization)</p> <p>Step 3: Use a multimeter to measure whether there is a 380V voltage between three live wires (requires measurement when power is on)</p> <p>220V machines do not experience this failure</p>

E03
Water flow
switch failure
or water flow
too low
protection

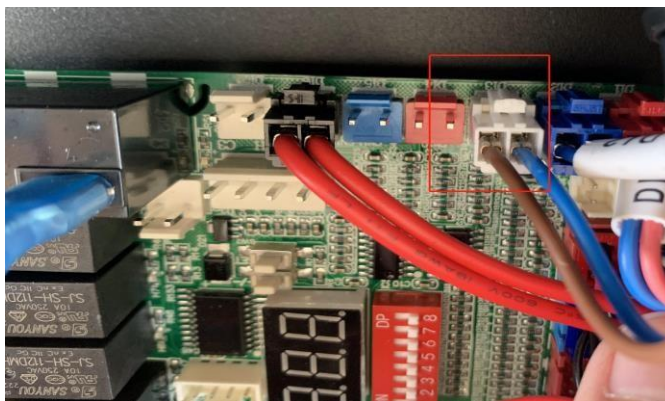

Repair method:

Step 1:

Check that the pipe valve is fully open (confirm that the water is flowing smoothly)

Step 2:

Check whether the water flow switch is installed backwards and whether the water flow switch model is correct

Step 3:

Check that the water flow switch cable port is not plugged into the wrong position (Water flow switch port D13 white)

E03
Water flow
switch failure
or water flow
too low
protection

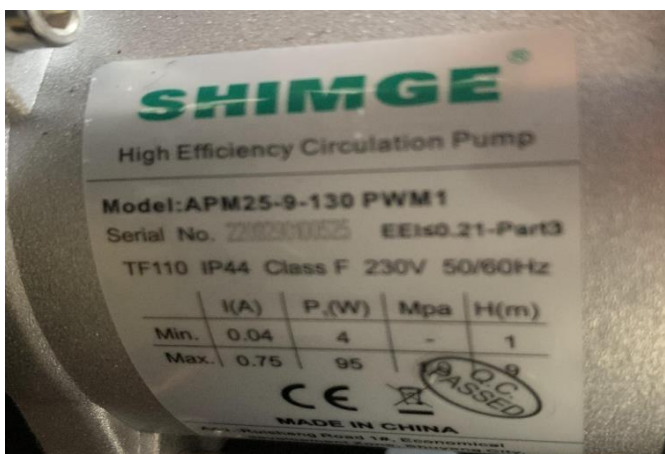
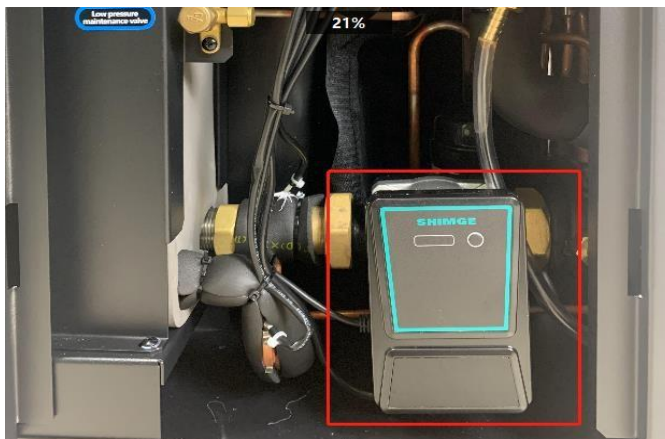

Step 4:



Check whether the circulating water pump is working properly and whether the water system is blocked

Step 5:

Check the pump head and whether the flow rate is sufficient (if it is not enough, add a hot water auxiliary pump)

Step 6:

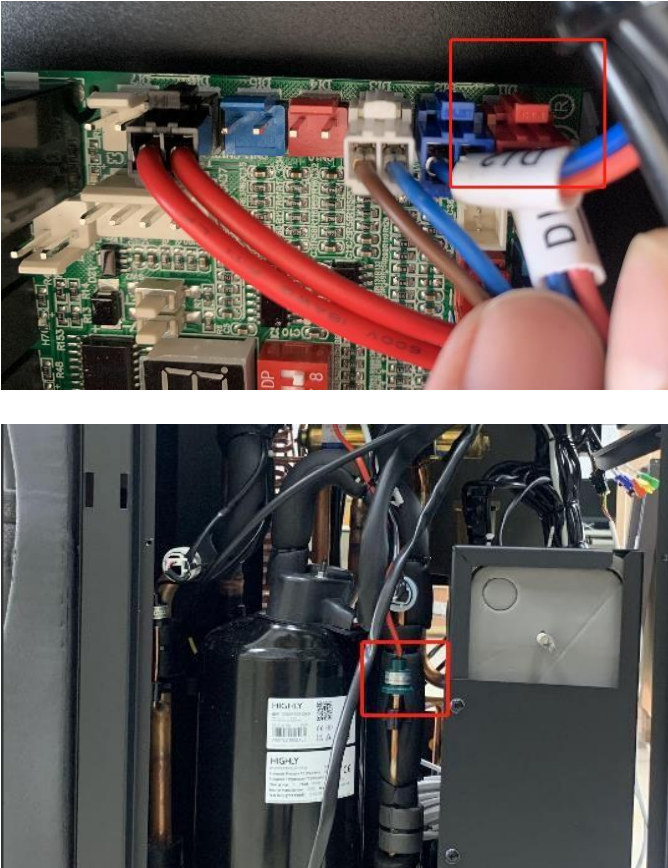
Check whether the external auxiliary pump is installed backward or reversed.

<p>E05 High voltage switch failure</p>		<p>Step 1: Check the high-pressure pressure switch for damage Whether the terminal position is correct (High voltage switch D11 red)</p>
<p>E05 High voltage switch failure</p>		<p>Step 2: Use a pressure gauge to connect the low-pressure access port to measure the system's excess refrigerant.</p>

E05
High voltage
switch failure

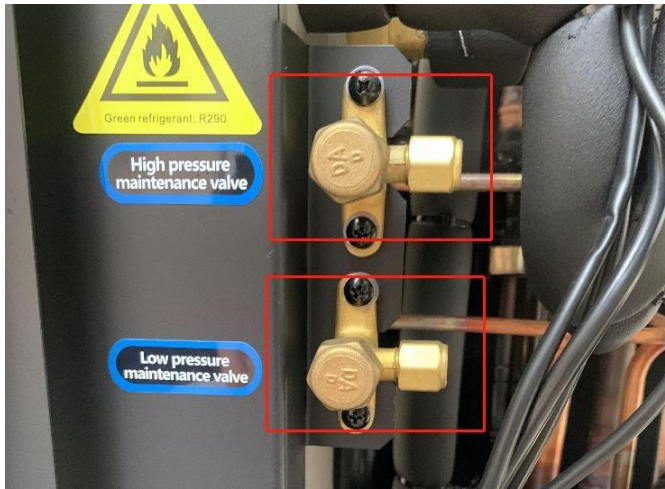

Step 3:

Check the system for blockages or air in the system.

Use the pressure gauge to connect the high and low pressure access ports at the same time to measure whether the operating pressure of the system is normal.

Step 3:
Check the system for blockages or air in the system. Use the pressure gauge to connect the high and low pressure access ports at the same time to measure whether the operating pressure of the system is normal.

E05
High voltage
switch failure



Step 4:
Check that the fan is operating
properly.

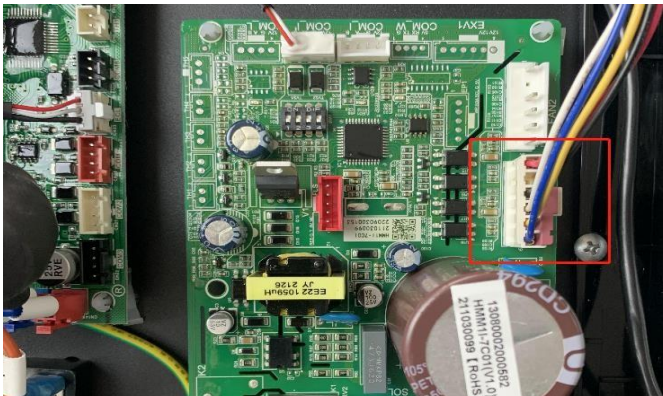

E05
High voltage
switch failure

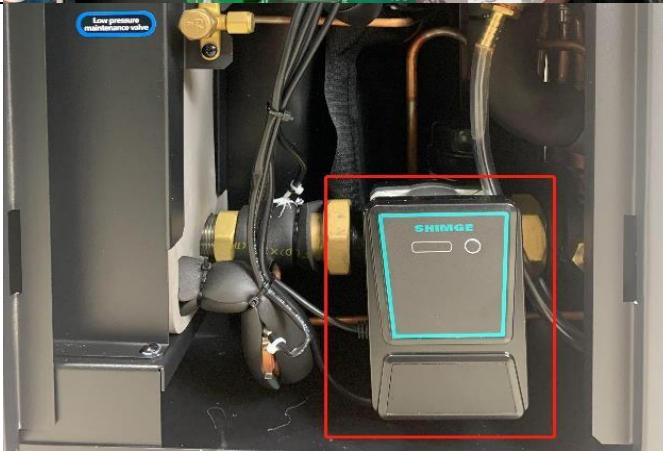

Step 5:
Check whether the pump is running
normally and whether the water flow of
the unit is normal.

E05
High voltage
switch failure

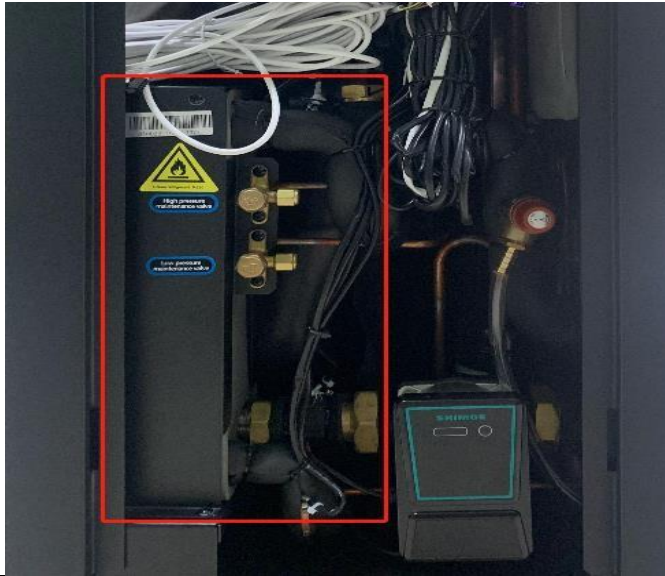

Step 6:
Check whether the water-side heat exchanger is seriously fouled
(In areas with poor water quality, oxalic acid and citric acid should be regularly used to clean the inside of the heat exchanger, or cold water pre-filtration should be installed.))

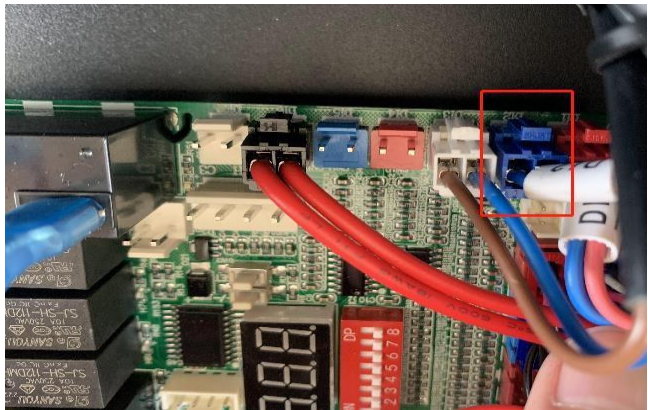
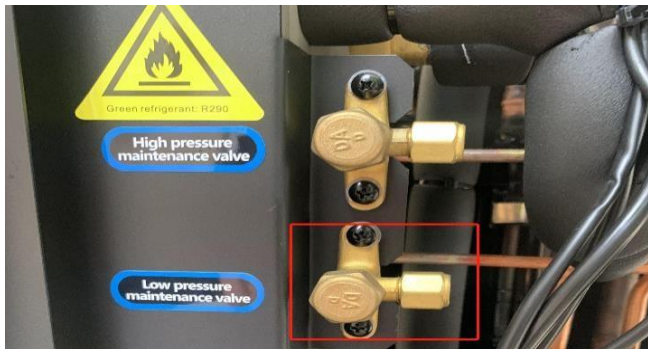
<p>E06 Low voltage switch failure</p>	 	<p>Step 1: Check the low pressure switch for damage Whether the terminal position is correct. (Low voltage switch D12 blue)</p>
<p>E06 Low voltage switch failure</p>		<p>Step 2: Use a pressure gauge to connect the low-pressure access port to measure whether the system refrigerant is missing (After replenishing the refrigerant, use foam to check whether the copper pipe weld has refrigerant leakage)</p>

E06
Low voltage
switch failure

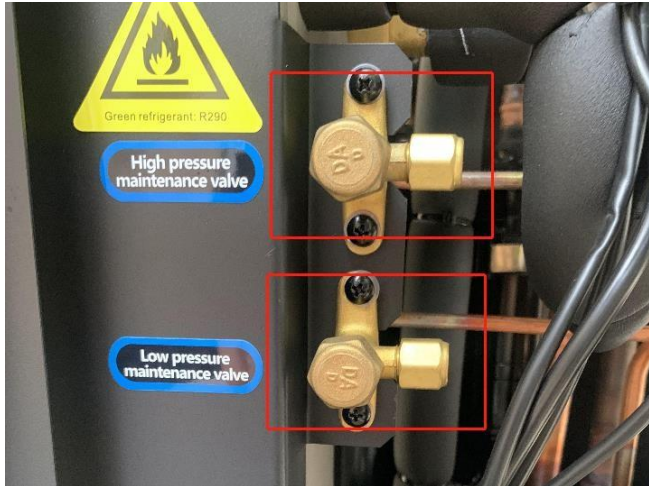
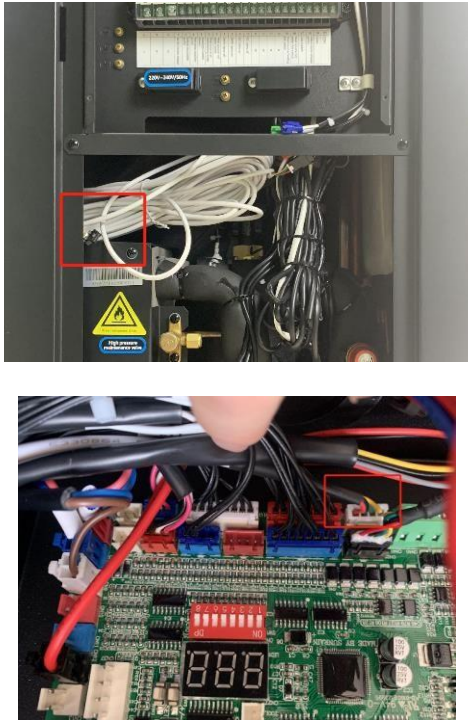
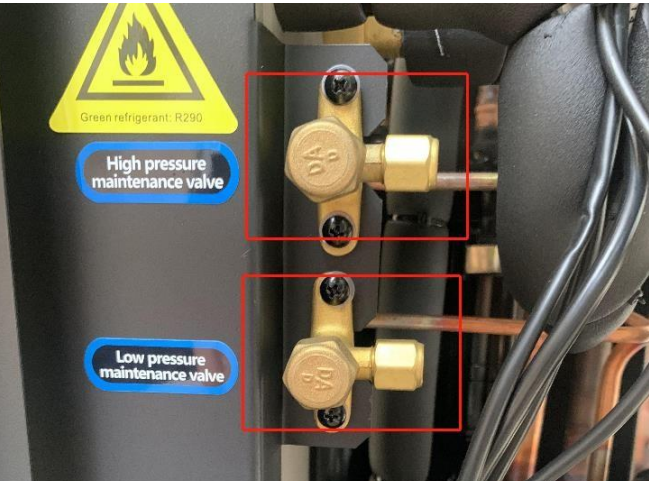

Step 3:
Check that the fan is operating
properly.

<p>E06 Low voltage switch failure</p>		<p>Step 4: Check the system for blockages.</p> <p>Use the pressure gauge to connect the high and low pressure access ports at the same time to measure whether the operating pressure of the system is normal.</p>
<p>E09 The remote controller is communicating with the motherboard is faulty</p>		<p>1: Check whether the communication between the remote controller and the motherboard is normal 2: Use a multimeter to measure whether the voltage output of the motherboard port is normal (white port)</p>
<p>E12 Excessive exhaust temperature protection</p>		<p>Step 1: Check the system for blockages or lack of refrigerant.</p> <p>Use the pressure gauge to connect the high and low pressure access ports at the same time to measure whether the operating pressure of the system is normal.</p>

E12
Excessive
exhaust
temperature
protection

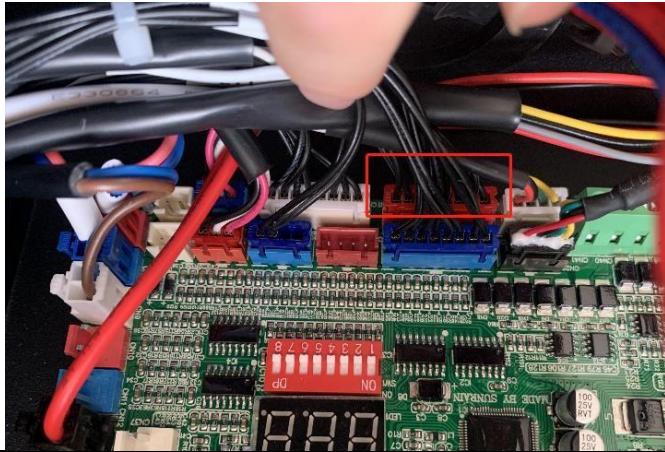
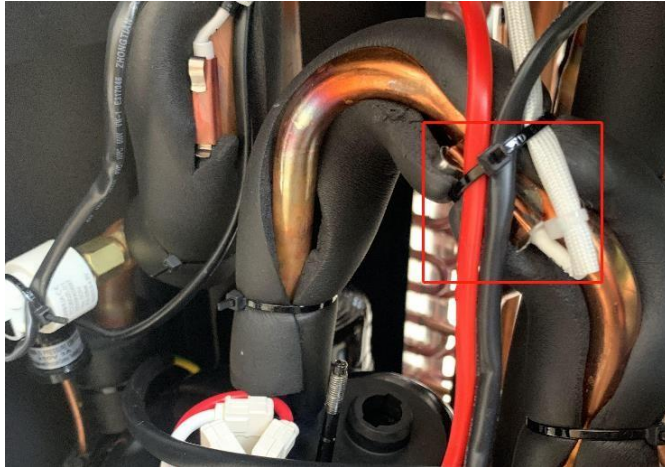

Step 2:
Check that the exhaust
temperature sensor is not
damaged and that the resistance
value is correct and measured
using a multimeter
(T3 red port)

E14
Hot water
tank
temperature
failure

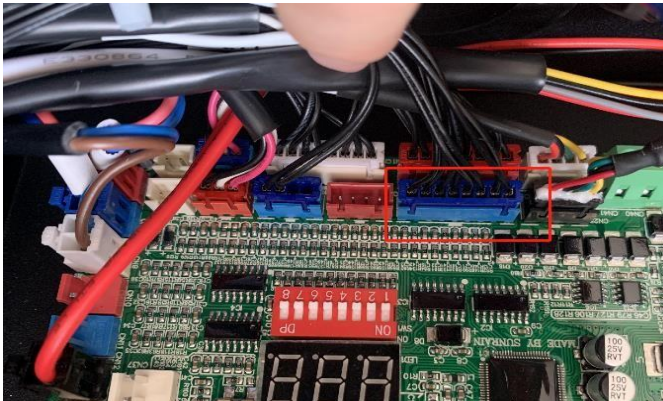
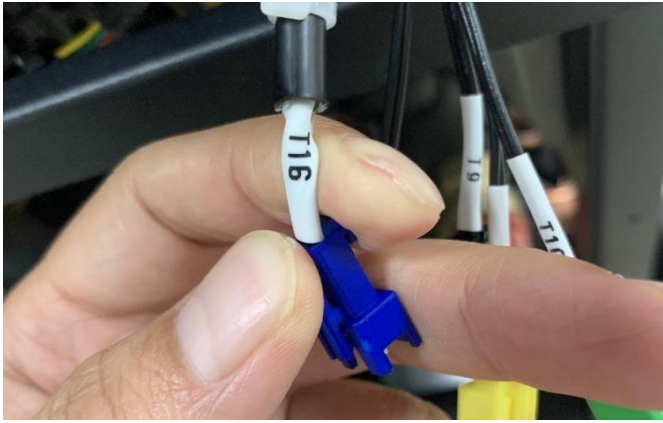

- 1: The sensor connection cable is open or disconnected
- 2: The sensor is damaged
- 3: The motherboard port is damaged
- 4: Use a multimeter to measure whether the resistance value is correct (T16 blue port)

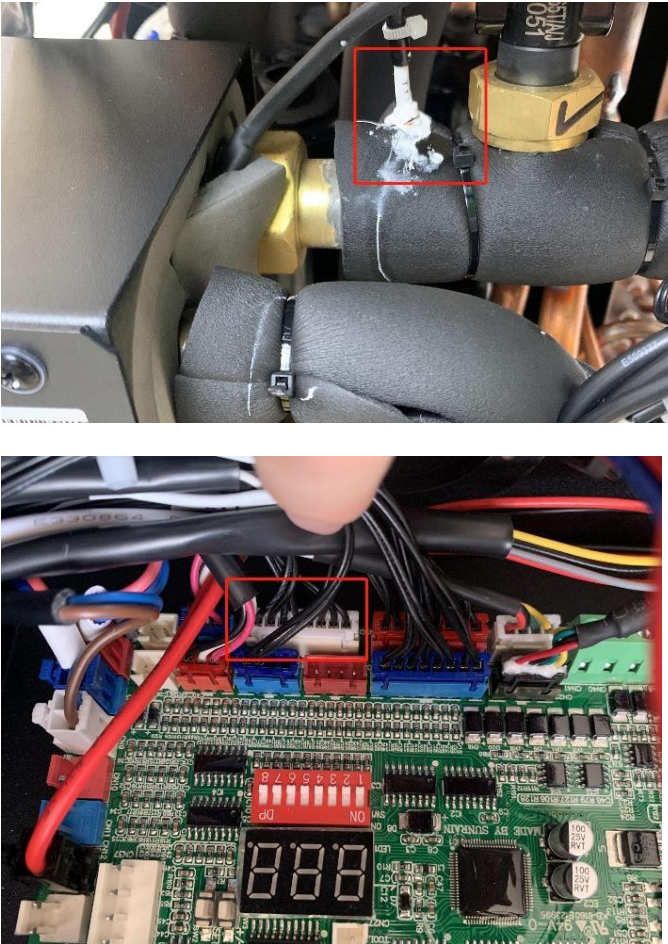
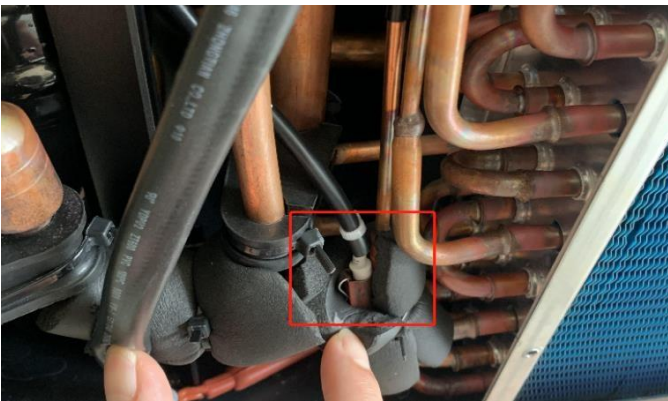
<p>E15 The inlet water temperature sensor is faulty</p>		<p>1: The sensor connection cable is open or disconnected 2: The sensor is damaged 3: The motherboard port is damaged 4: Use a multimeter to measure whether the resistance value is correct (T8 white port)</p>
<p>E16 Coil sensor failure</p>		<p>1: The sensor connection cable is open or disconnected 2: The sensor is damaged 3: The motherboard port is damaged 4: Use a multimeter to measure whether the resistance value is correct (TI Red Port)</p>

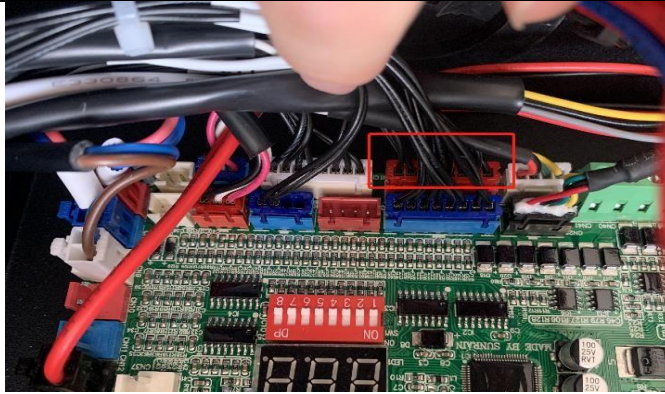

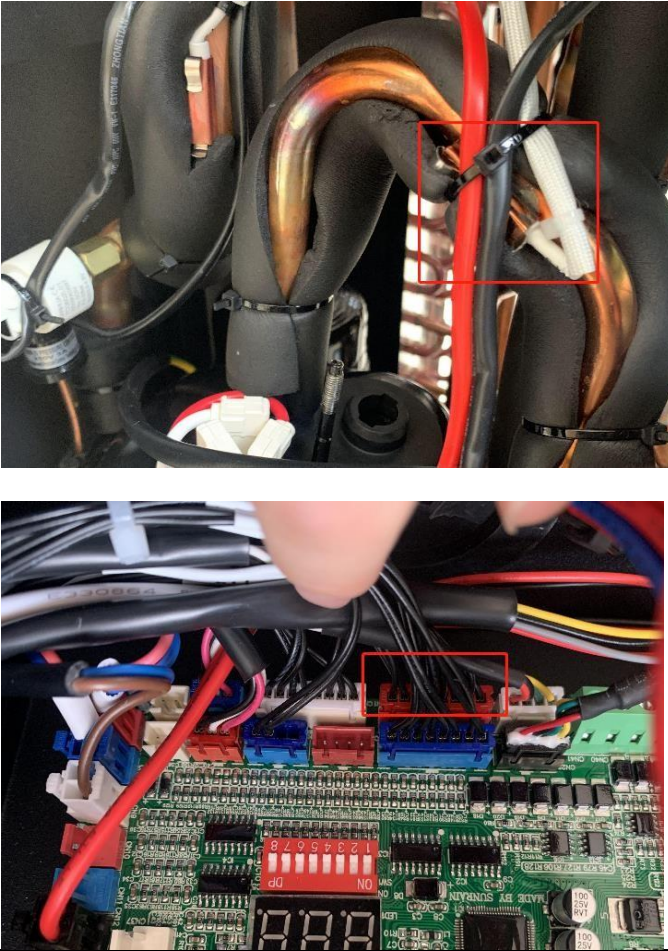
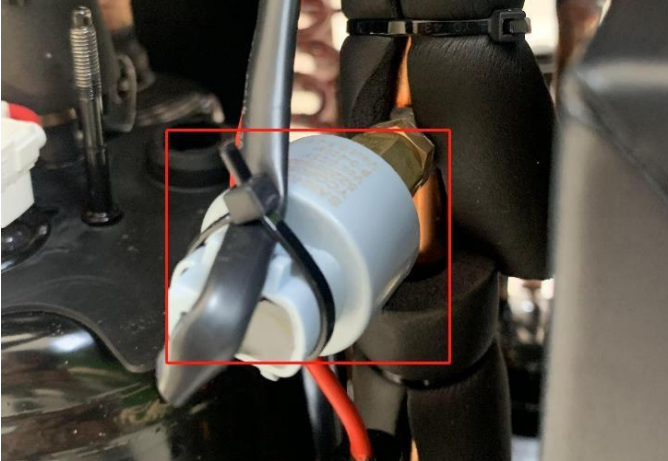
<p>E18 Exhaust sensor failure</p>		<p>1: The sensor connection cable is open or disconnected 2: The sensor is damaged 3: The motherboard port is damaged 4: Use a multimeter to measure whether the resistance value is correct (TI Red Port)</p>
<p>E33 High pressure sensor failure</p>		<p>1: The sensor connection wire is disconnected or open 2: Sensor failure 3: The motherboard port is damaged (D11 red port)</p>

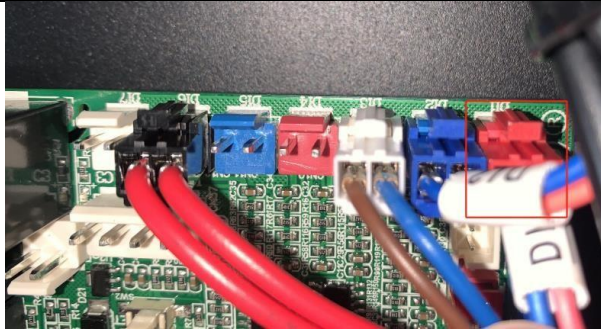

E34
Low voltage
sensor failure

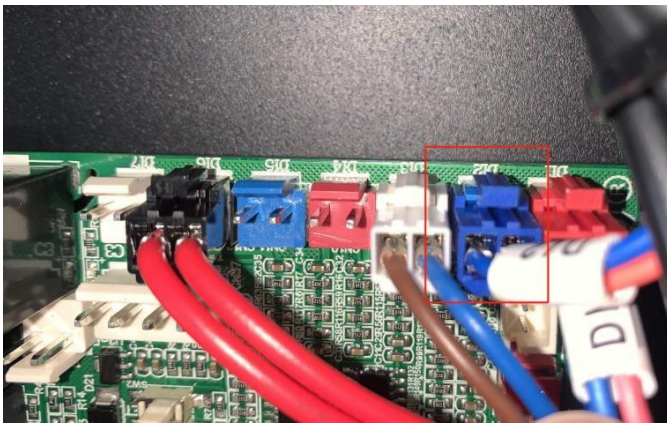

- 1: The sensor connection wire is disconnected or open
- 2: Sensor failure
- 3: The motherboard port is damaged (D12 blue port)

E37
The temperature difference between the inlet and outlet water is too large to protect

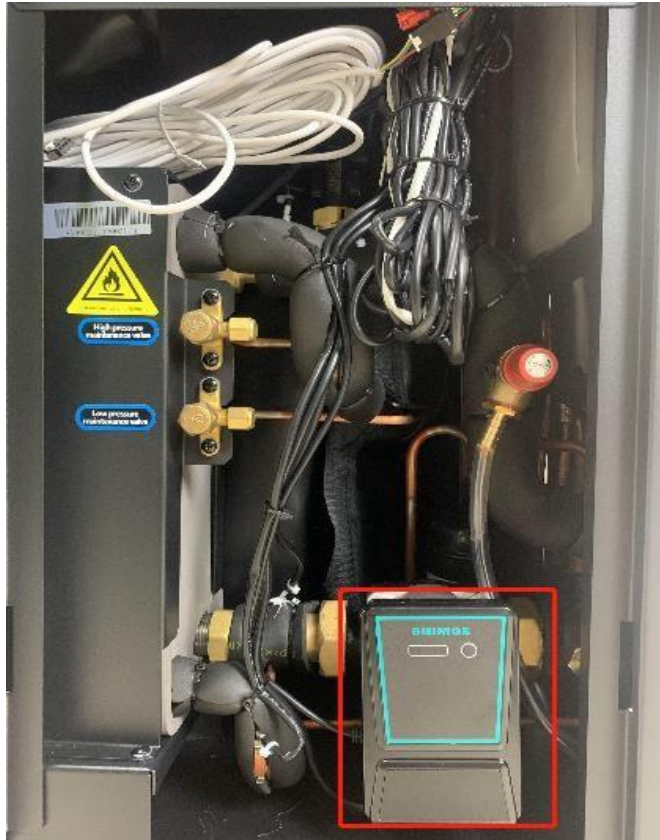

- Step 1:
Check that the piping valves are fully open.
- Step 2:
Check if the pump is working.
- Step 3:
Check whether the rated head of the pump and the rated flow rate meet the normal operation requirements of the machine.
- Step 4:
Manually drain the drain pump and drain the air from the pipeline.

Schedule

Schedule A: Heat dissipation per unit of ground and heat loss from the ground in the lower layer or soil

1. The heat dissipation per unit ground area of PE-X pipe and the heat loss of downward conversion

The surface layer is cement or ceramic, thermal resistance <0.02 ($\text{m}^2 \cdot \text{K}/\text{W}$), the heat dissipation per unit ground and the heat loss from downward turn can be shown in the table A1.1

Table A 1.1

Average Water Temperature	Indoor Air Temperature	Heating Pipe Space (mm)									
		300		250		200		150		100	
(°C)	(°C)	Heat dissipation	Heat Loss	Heat dissipation	Heat Loss	Heat dissipation	Heat Loss	Heat dissipation	Heat Loss	Heat dissipation	Heat Loss
35	16	84.7	23.8	92.5	24.0	100.5	24.6	108.9	24.8	116.6	24.8
	18	76.4	21.7	83.3	22.0	90.4	22.6	97.9	22.7	104.7	22.7
	20	68.0	19.9	74.0	20.2	80.4	20.5	87.1	20.5	93.1	20.5
	22	59.7	17.7	65.0	18.0	70.5	18.4	76.3	18.4	81.5	18.4
	24	51.6	15.6	56.1	15.7	60.7	15.7	65.7	15.7	70.1	15.7
40	16	108.0	29.7	118.1	29.8	128.7	30.5	139.6	30.8	149.7	30.8
	18	99.5	27.4	108.7	27.9	118.4	28.5	128.4	28.7	137.6	28.7
	20	91.0	25.4	99.4	25.7	108.1	26.5	117.3	26.7	125.6	26.7
	22	82.5	23.8	90.0	23.9	97.9	24.4	106.2	24.6	113.7	24.6
	24	74.2	21.3	80.9	21.5	87.8	22.4	95.2	22.4	101.9	22.4
45	16	131.8	35.5	144.4	35.5	157.5	36.5	171.2	36.8	183.9	36.8
	18	123.3	33.2	134.8	33.9	147.0	34.5	159.8	34.8	171.6	34.8
	20	114.5	31.7	125.3	32.0	136.6	32.4	148.5	32.7	159.3	32.7
	22	106.0	29.4	115.8	29.8	126.2	30.4	137.1	30.7	147.1	30.7
	24	97.3	27.6	106.5	27.3	115.9	28.4	125.9	28.6	134.9	28.6
50	16	156.1	41.4	171.1	41.7	187.0	42.5	203.6	42.9	218.9	42.9
	18	147.4	39.2	161.5	39.5	176.4	40.5	192.0	40.9	206.4	40.9
	20	138.6	37.3	151.9	37.5	165.8	38.5	180.5	38.9	194.0	38.9
	22	130.0	35.2	142.3	35.6	155.3	36.5	168.9	36.8	181.5	36.8
	24	121.2	33.4	132.7	33.7	144.8	34.4	157.5	34.7	169.1	34.7
55	16	180.8	47.1	198.3	47.8	217.0	48.6	236.5	49.1	254.8	49.1
	18	172.0	45.2	188.7	45.6	206.3	46.6	224.9	47.1	242.0	47.1
	20.0	163.1	43.3	178.9	43.8	195.6	44.6	213.2	45.0	229.4	45.0
	22.0	154.3	41.4	169.3	41.5	185.0	42.5	201.5	43.0	216.9	43.0
	24.0	145.5	39.4	159.6	39.5	174.3	40.5	189.9	40.9	204.3	40.9

Note: Calculation Condition: The nominal outer diameter of heating pipe is 20mm, the thickness of the fill layer is 50mm, The thickness of polystyrene foam plastic insulation layer is 20mm, the temperature difference between water supply and return is 10°C.

The ground layer is plastic material, thermal resistance = 0.075 (m². K/W), the heat dissipation per unit ground and the heat loss of downward conversion can be calculated according to Table A1.2

Table A 1.2

Average Water Temperature (°C)	Indoor Air Temperature (°C)	Heating Pipe Space (mm)									
		300		250		200		150		100	
		Heat dissipation	Heat Loss	Heat dissipation	Heat Loss	Heat dissipation	Heat Loss	Heat dissipation	Heat Loss	Heat dissipation	Heat Loss
35	16	67.7	24.2	72.3	24.3	76.8	24.6	81.3	25.1	85.3	25.7
	18	61.1	22.0	65.2	22.2	69.3	22.5	73.2	22.9	76.9	23.4
	20	54.5	19.9	58.1	20.1	61.8	20.3	65.3	20.7	68.5	21.3
	22	48.0	17.8	51.1	18.1	54.3	18.1	57.4	18.5	60.2	18.8
	24	41.5	15.5	44.2	15.9	46.9	16.0	49.5	16.3	51.9	16.7
40	16	85.9	30.0	91.8	30.4	97.7	30.7	103.4	31.3	108.7	32.0
	18	79.2	27.9	84.6	28.1	90.0	28.6	95.3	29.1	100.1	29.8
	20	72.5	26.0	77.5	26.0	82.4	26.4	87.2	26.9	91.5	27.6
	22	65.9	23.7	70.3	24.0	74.8	24.2	79.1	24.7	83.0	25.3
	24	59.3	21.4	63.2	21.9	67.2	22.1	71.1	22.5	74.6	23.1
45	16	104.5	35.8	111.7	36.1	119.0	36.8	126.1	37.6	132.6	38.5
	18	97.7	33.8	104.5	34.1	111.2	34.7	117.8	35.4	123.9	36.3
	20	90.9	31.8	97.2	32.1	103.5	32.6	109.6	33.2	115.2	33.9
	22	84.2	29.7	89.9	30.0	95.8	30.4	101.4	31.0	106.5	31.9
	24	77.4	27.7	82.7	28.0	88.1	28.2	93.2	28.8	97.9	29.4
50	16	123.3	41.8	131.9	42.2	140.6	42.9	149.1	43.9	156.9	44.9
	18	116.5	39.6	124.6	40.3	132.8	40.8	141.1	41.7	148.1	42.7
	20	109.6	37.7	117.3	38.1	125.0	38.7	132.4	39.5	139.3	40.4
	22	102.8	35.5	109.9	36.2	117.1	36.6	124.1	37.3	130.6	38.3
	24	96.0	33.7	102.7	33.9	109.4	34.4	115.9	35.1	121.8	35.9
55	16	142.4	47.7	152.3	48.6	162.5	49.1	172.4	50.2	181.5	51.4
	18	135.4	45.8	145.0	46.2	154.6	47.0	164.0	48.0	172.7	49.3
	20	128.6	43.7	137.6	41.3	146.8	44.9	155.6	45.9	163.8	47.0
	22	121.7	41.6	130.2	42.2	138.9	42.8	147.3	43.7	155.0	44.9
	24	114.9	39.6	122.9	39.9	131.0	40.7	138.9	41.5	146.2	42.6

Note: Calculation Condition: The nominal outer diameter of heating pipe is 20mm, the thickness of the fill layer is 50mm, The thickness of polystyrene foam plastic insulation layer is 20mm, the temperature difference between water supply and return is 10°C.

The ground layer is wood floor material, thermal resistance = 0.1 (m². K/W), the heat dissipation per unit ground and the heat loss of downward conversion can be calculated according to Table A 1.3

Table A 1.3

Average Water Temperature (°C)	Indoor Air Temperature (°C)	Heating Pipe Space (mm)									
		300		250		200		150		100	
		Heat dissipation	Heat Loss	Heat dissipation	Heat Loss	Heat dissipation	Heat Loss	Heat dissipation	Heat Loss	Heat dissipation	Heat Loss
35	16	62.4	24.4	66.0	24.6	69.6	25.0	73.1	25.5	76.2	26.1
	18	56.3	22.3	59.6	22.5	62.8	22.9	65.9	23.3	68.7	23.9
	20	50.3	20.1	53.1	20.5	56.0	20.7	58.8	21.1	61.3	21.6
	22	44.3	18.0	46.8	18.2	49.3	18.5	51.7	18.9	53.9	19.3
	24	38.4	15.7	40.5	16.1	42.6	16.3	44.7	16.6	46.5	17.0
40	16	79.1	30.2	83.7	30.7	88.4	31.2	92.8	31.9	96.9	32.5
	18	72.9	28.3	77.2	28.6	81.5	29.0	85.5	29.6	89.3	30.3
	20	66.8	26.3	70.7	26.5	74.6	26.9	78.3	27.4	81.7	28.1
	22	60.7	24.0	64.2	24.4	67.7	24.7	71.1	25.2	74.1	25.8
	24	54.6	21.9	57.8	22.1	60.9	22.5	63.9	22.9	66.6	23.4
45	16	96.0	36.4	101.8	36.9	107.5	37.5	112.9	38.2	117.9	39.1
	18	89.8	34.1	95.1	34.8	100.5	35.3	105.6	36.0	110.2	36.8
	20	83.6	32.2	88.6	32.7	93.5	33.1	98.2	33.8	102.6	34.5
	22	77.4	30.1	82.0	30.4	86.6	30.9	90.9	31.6	94.9	32.4
	24	71.2	28.0	75.4	28.4	79.6	28.8	83.6	29.3	87.3	30.0
50	16	113.2	42.3	120.0	43.1	126.8	43.7	133.4	44.6	139.3	45.6
	18	106.9	40.3	113.3	41.0	119.8	41.6	125.9	42.4	131.6	43.4
	20	100.7	38.1	106.7	38.7	112.7	39.4	118.5	40.2	123.8	41.2
	22	94.4	36.1	100.1	36.7	105.7	37.2	111.1	38.0	116.1	38.9
	24	88.2	34.0	93.4	34.6	98.7	35.1	103.8	35.7	108.4	36.6
55	16	130.5	48.6	138.5	49.1	146.4	50.0	154.0	51.1	161.0	52.2
	18	124.2	46.6	131.8	47.1	139.3	47.9	146.6	48.9	153.2	50.0
	20	118.0	44.4	125.1	45.0	132.2	45.7	139.1	46.7	145.4	47.8
	22	111.7	42.2	118.4	42.8	125.2	43.6	131.6	44.5	137.6	45.5
	24	105.4	40.1	111.7	40.8	118.1	41.4	124.2	42.2	129.8	43.2

Note: Calculation Condition: The nominal outer diameter of heating pipe is 20mm, the thickness of the fill layer is 50mm, The thickness of polystyrene foam plastic insulation layer is 20mm, the temperature difference between water supply and return is 10°C.

2. The heat dissipation and downward heat loss per unit ground area of PB pipe

The surface layer is cement or ceramic, thermal resistance <0.02 ($\text{m}^2 \cdot \text{K}/\text{W}$), the heat dissipation per unit ground and the heat loss from downward turn can be shown in the table A 2.1 compute

Table A 2.1

Average Water Temperature (°C)	Indoor Air Temperature (°C)	Heating Pipe Space (mm)									
		300		250		200		150		100	
		Heat dissipation	Heat Loss	Heat dissipation	Heat Loss	Heat dissipation	Heat Loss	Heat dissipation	Heat Loss	Heat dissipation	Heat Loss
35	16	76.5	21.9	84.3	22.3	92.7	22.9	101.8	23.7	111.1	24.1
	18	68.9	20.1	75.9	20.4	83.5	20.9	91.5	21.7	99.8	22.6
	20	61.4	18.2	67.5	18.7	74.3	19.0	81.4	19.6	88.6	20.6
	22	53.9	16.5	59.3	16.8	65.1	17.2	71.4	17.5	77.6	18.5
	24	46.6	14.6	51.2	14.8	56.1	15.3	61.4	15.7	66.8	16.4
40	16	97.3	27.1	107.4	27.6	118.5	28.3	130.3	29.2	142.4	30.6
	18	89.6	25.4	98.9	25.9	109.1	26.4	119.9	27.2	130.9	28.6
	20	82.0	23.5	90.4	24.1	99.6	24.6	109.5	25.2	119.5	26.5
	22	74.4	21.7	82.0	22.1	90.3	22.7	99.2	23.3	108.2	24.4
	24	66.8	19.9	73.6	20.3	81.0	20.8	88.9	21.5	96.9	22.4
45	16	118.6	32.4	131.1	33.0	144.9	33.8	159.6	35.1	174.7	36.6
	18	110.8	30.6	122.5	31.2	135.3	31.9	149.0	33.0	163.1	34.6
	20	103.1	28.8	113.9	29.4	125.7	30.0	138.4	31.2	151.4	32.5
	22	95.3	27.0	105.3	27.5	116.2	28.2	127.9	29.1	139.8	30.5
	24	87.7	25.2	96.7	25.6	106.7	26.3	117.4	27.2	128.3	28.4
50	16	140.3	37.6	155.2	38.4	171.8	39.4	189.5	40.8	207.9	42.7
	18	132.4	35.8	146.5	36.5	162.1	37.5	178.8	38.9	196.0	40.6
	20	124.6	34.0	137.8	34.7	152.4	35.7	168.1	36.8	184.2	38.6
	22	116.8	32.2	129.1	32.9	142.7	33.8	157.3	35.0	172.4	36.6
	24	109.0	30.5	120.4	31.1	133.1	31.9	146.7	32.9	160.7	34.5
55	16	162.2	42.9	179.7	43.7	199.1	44.9	220.0	46.5	241.7	48.7
	18	154.3	41.1	170.9	42.0	189.3	43.0	209.2	44.4	229.7	46.7
	20	146.4	39.3	162.2	40.1	179.5	41.3	198.3	42.6	217.7	44.7
	22	138.5	37.5	153.4	38.3	169.8	39.5	187.5	40.7	205.8	42.7.0
	24	130.7	35.8	144.6	36.5	160.0	37.5	176.7	38.7	193.9	40.6

Note: Calculation Condition: The nominal outer diameter of heating pipe is 20mm, the thickness of the fill layer is 50mm, The thickness of polystyrene foam plastic insulation layer is 20mm, the temperature difference between water supply and return is 10°C.

The ground layer is plastic material, thermal resistance = 0.075 (m². K/W), the heat dissipation per unit ground and the heat loss of downward turn can be calculated according to Table A 2.2

Table A 2.2

Average Water Temperature (°C)	Indoor Air Temperature (°C)	Heating Pipe Space (mm)									
		300		250		200		150		100	
		Heat dissipation	Heat Loss	Heat dissipation	Heat Loss	Heat dissipation	Heat Loss	Heat dissipation	Heat Loss	Heat dissipation	Heat Loss
35	16	62.0	23.2	66.8	23.5	72.0	23.5	77.2	24.2	82.3	24.8
	18	55.9	21.3	60.3	21.6	64.9	21.6	69.5	22.1	74.2	22.6
	20	49.9	19.3	53.7	19.9	58.0	19.9	62.0	20.0	66.1	20.6
	22	43.9	17.4	47.2	17.9	51.0	17.9	54.5	17.9	58.0	18.5
	24	38.0	15.3	40.8	15.9	44.1	15.9	47.1	15.9	50.1	16.3
40	16	78.5	28.9	84.7	29.6	91.5	29.6	98.1	30.1	104.8	30.9
	18	72.4	27.1	78.1	27.7	84.4	27.7	90.5	27.8	96.5	28.8
	20	66.3	25.1	71.5	25.7	77.2	25.7	82.8	25.8	88.3	26.8
	22	60.2	23.1	64.9	23.7	70.1	23.7	75.1	23.8	80.1	24.5
	24	54.1	21.1	58.3	21.7	63.0	21.7	67.5	21.7	71.9	22.3
45	16	95.4	34.6	103.0	35.4	111.4	35.4	119.5	36.1	127.7	37.2
	18	89.2	32.5	96.3	33.4	104.1	33.4	111.7	33.9	119.4	35.0
	20	83.0	30.6	89.6	31.5	96.9	31.5	104.0	31.8	111.0	32.9
	22	76.9	28.5	82.9	29.5	89.7	29.5	96.2	29.6	102.7	30.8
	24	70.7	26.9	76.3	27.5	82.5	27.5	88.5	27.5	94.4	28.4
50	16	112.5	40.2	121.6	41.2	131.5	41.2	141.3	41.9	151.1	43.4
	18	106.2	38.4	114.8	39.3	124.2	39.3	133.4	40.1	142.6	41.3
	20	100.0	36.4	108.0	37.4	116.9	37.4	125.5	38.1	134.2	39.1
	22	93.8	34.5	101.3	35.4	109.6	35.4	117.7	35.8	125.7	37.0
	24	87.6	32.3	94.6	33.4	102.3	33.4	109.8	33.6	117.4	34.8
55	16	129.8	45.7	140.3	47.1	151.1	47.1	163.4	47.7	174.8	49.6
	18	122.8	44.0	132.9	44.0	145.1	44.0	155.9	45.5	166.7	47.0
	20	117.2	42.1	126.8	42.7	137.2	42.7	147.5	43.7	157.7	45.4
	22	110.9	40.3	120.0	41.0	129.8	41.0	139.5	41.8	149.2	43.4
	24	104.7	38.2	113.2	39.2	122.5	39.2	131.6	39.9	140.7	41.2

Note: Calculation Condition: The nominal outer diameter of heating pipe is 20mm, the thickness of the fill layer is 50mm, The thickness of polystyrene foam plastic insulation layer is 20mm, the temperature difference between water supply and return is 10°C.

The ground layer is wood floor material, thermal resistance = 0.1 (m². K/W), the heat dissipation per unit ground and the heat loss of downward turn can be calculated according to

Table A 2.3

Table A 2.3

Average Water Temperature (°C)	Indoor Air Temperature (°C)	Heating Pipe Space (mm)									
		300		250		200		150		100	
		Heat dissipation	Heat Loss	Heat dissipation	Heat Loss	Heat dissipation	Heat Loss	Heat dissipation	Heat Loss	Heat dissipation	Heat Loss
35	16	57.4	23.1	61.5	23.1	65.6	23.9	69.7	24.6	73.7	25.4
	18	51.8	21.4	55.5	21.4	59.2	21.7	62.9	22.4	66.5	23.1
	20	46.2	19.2	49.5	19.2	52.7	19.9	56.1	20.2	59.3	20.9
	22	40.7	17.7	43.5	17.7	46.5	17.5	49.3	18.0	52.1	18.7
	24	35.2	15.2	37.7	15.2	40.2	15.6	42.7	15.8	45.1	16.4
40	16	72.6	29.3	77.8	29.3	83.1	29.8	88.5	30.6	93.7	31.6
	18	66.9	27.3	71.8	27.3	76.6	27.7	81.5	28.4	86.3	29.4
	20	61.4	24.7	65.8	24.7	70.2	25.6	74.6	26.4	79.0	27.2
	22	55.8	22.7	59.8	22.7	63.7	23.6	67.8	24.2	71.7	24.9
	24	50.2	20.7	53.8	20.7	57.3	21.3	60.9	21.9	64.5	22.7
45	16	88.2	34.4	94.7	34.4	101.1	35.4	107.6	36.5	114.0	37.8
	18	82.4	32.4	88.5	32.4	94.5	33.6	100.6	34.6	106.6	35.6
	20	76.7	30.4	82.4	30.4	87.9	31.5	93.6	32.4	99.2	33.5
	22	71.1	28.4	76.3	28.4	81.4	29.4	86.7	30.1	91.8	31.2
	24	65.6	26.4	70.2	26.4	74.9	27.4	79.7	28.1	84.4	29.0
50	16	103.9	40.1	111.6	40.1	119.2	41.5	127.0	42.6	134.6	44.3
	18	98.2	38.1	105.4	38.1	112.6	39.3	119.9	40.5	127.1	42.0
	20	92.4	36.1	99.2	36.1	106.0	37.4	112.9	38.5	119.6	39.9
	22	86.7	34.2	93.0	34.2	99.4	35.3	105.8	36.3	112.2	37.6
	24	81	32.2	86.9	32.2	92.8	33.2	98.8	34.2	104.7	35.4
55	16	119.7	45.9	128.6	45.9	137.5	47.3	146.6	48.8	155.5	50.5
	18	114	43.8	122.4	43.8	130.8	45.5	139.5	46.8	148.0	48.5
	20	108.1	41.9	116.2	41.9	124.2	43.5	132.4	44.5	140.5	46.2
	22	102.3	39.9	110.0	39.9	117.5	41.5	125.3	42.4	132.9	44.1
	24	96.6	37.9	103.8	37.9	111.0	39.1	118.2	40.3	125.4	41.7

Note: Calculation Condition: The nominal outer diameter of heating pipe is 20mm, the thickness of the fill layer is 50mm, The thickness of polystyrene foam plastic insulation layer is 20mm, the temperature difference between water supply and return is 10°C.

Schedule B: Coefficient of expansion of water

temperatu re	Coefficient of expansion
0	0.00013
10	0.00025
15	0.00085
20	0.00180
25	0.00289
30	0.00425
35	0.00582
40	0.00782
45	0.00984
50	0.01207
55	0.01447
60	0.01704
65	0.01979
70	0.02269
75	0.02575
80	0.02898
85	0.03236
90	0.03590
95	0.03958
100	0.04342

Note: The coefficient of expansion of the volume of water relative to 4°C at different temperatures

