

Rechargeable Lithium-ion Battery System

Ai-LB 5K Pro Quick Installation Guide

Version: 1.5

Doc. No.: PT-Q-231C02

Date: 2023/07/05



© Copyright 2023 Solplanet Limited. All rights reserved. Specifications are subject to change without prior notice.

Solplanet does not accept any responsibility whatsoever for potential errors or possible lack of information in this document.



Before installation, Please read this guide.

1. Read this guide carefully before installation to understand product features and safety precautions.
2. Installers should be well trained to fully understand grid-connected photovoltaic power systems and national/regional standards.
3. Installers must use insulated tools and wear safety equipment.
4. As required by local regulations, an overcurrent protection and isolation device that operates both positive and negative conductors simultaneously is required between inverter and battery system and also between parallel batteries. The cable needs to be prepared by the installer, cable specification: 25mm² / 4 AWG, cable terminal model: E25-16.
5. Before installation, ensure that battery pack is switched off, and open any associated circuit breakers and disconnect switches.

1 Handling Precautions and Guidelines for Product

These Handling Precautions and Guidelines for Rechargeable Battery System (“Handling Precautions and Guidelines”) shall only apply to the packs manufactured by AISWEI New Energy Technology (Yangzhong) Co., Ltd (hereinafter referred to as “AISWEI”). Customer shall strictly follow these Handling Precautions and Guidelines, and shall alert its customers, contract manufacturers, agents, distributors, service providers and end users of the risks of the packs and shall ensure that Customer’s obligations as specified in the Document as well as the Handling Precautions and Guidelines are, through a printed label on host device, or through Customer’s Quick Installation Guide, or a help file or Customer’s Internet website, contractually imposed on Customer’s own customers and distributors, and by them further down to the end users so that the entire chain is committed to the above obligations and so that the products are properly handled, operated, transported, used and maintained.

Statement(1) :

Customer is requested to contact AISWEI in advance, if and when the customer needs other applications or operating conditions than those described in this Document. Additional experimentation may be required to verify performance and safety under such conditions

Statement (2) :









AISWEI will take no responsibility for any accident or liabilities in the event the Product is used for applications or under conditions other than those described in this Document.

- Use Product under specified charge/discharge conditions.
- Do not immerse in water.
- Do not heat.

- Do not attempt to crush, drop or penetrate the pack.
- Do not attempt to have any modification/.
- Leave Product in cool places.
- Stop using Product with any colour change or mechanical damage detected during assembling, charging, normal operation and storage .
- In case of leakage or smells, track to thermal source, remove the thermal source and clean with water.
- Do not place or leave the pack and equipment in the reach of children so that they are not able to swallow or mistreat the product. In case of ingestion, consult with a doctor immediately.
- Keep leaked electrolyte away from eyes or skin. In case of leakage contact with eyes or skin, immediately clean with water and seek help from a doctor. Serious damages can be caused due to delayed treatment.
- Do not put the pack into a fire. Do not use it or leave it in a place near fire, heaters, or high temperature sources. The heat can melt pack insulator and damage safety vent, resulting in overheating, explosion or fire of the pack .
- Do not submerge the product in water, or wet the product. If the protective devices are damaged, abnormal charging current and voltage may cause a chemical reaction within the product, which may result in overheating, explosion and even fire of the pack .
- Do not connect positive (+) and negative (-) terminals of the pack reversely.
- Do not short circuit. Do not contact the pack terminals (+ and -) directly with a wire or any metal (like a metal necklace or a hairpin). Otherwise, the pack is short circuited and generates excessive current, which may result in overheating, explosion, or fire of the pack .
- Do not throw or drop the pack. Strong impact may damage the protective devices and an abnormal chemical reaction might occur during charge, resulting in overheating, explosion, or fire of the pack.
- Do not drive a nail in, hit with a hammer, or stamp on the pack. Otherwise, the pack may be deformed and short circuited, resulting in overheating, explosion, or fire of the pack.
- Do not solder the pack directly. Heat applied during soldering may damage the insulator of the safety vent and mechanism, resulting in overheating, explosion, or fire of the pack.
- Do not disassemble or alter the pack. The pack employs a safety mechanism and a protection device in order to avoid any danger. If they are damaged, the pack might overheat, explode or catch a fire.
- Do not put the pack in a microwave oven or a pressure cooker. Sudden heat may damage the sealing of the pack and may cause overheating, explosion, or fire of the pack.
- Do not leave the pack in a charger or equipment if it generates an odour and/or heat, changes colour and /or shape, leaks electrolyte, or encounters any other abnormality. In such a case, immediately take the pack out of the charger or equipment and keep it away from fire. Otherwise, the pack might overheat, explode, or catch a fire.
- Stop charging or using the battery after battery reaches its lifetime, otherwise, as the PACK might cause heat generation, explosion, or fire.
- Do not use the pack beyond specified conditions. Otherwise, the pack might encounter overheating, damage, or performance deterioration .

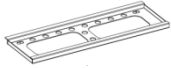
- Read the instructions regarding the installation and operation so as to avoid damages due to incorrect operations.
- The pack may have insufficient power capacity after long storage.
- Knockoff or counterfeit battery.
- Any inconsistency between serial number, model number, and product code.

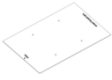
2 Product Packing List

Item Name	ID	Details	Quantity	Image	Notes
Battery	A	Ai-LB 5K Pro 460x165x652 mm 18.11x6.50x25.67 in	1		
Output Cable	B	Positive: orange plug, 25 mm ² / 4 AWG, L:1.5 m (59.06 in) to SC25-8 ring terminal. Negative: black plug, 25 mm ² / 4 AWG, L:1.5 m (59.06 in) to SC25-8 ring terminal	2		Continuo us flow capacity : 100A
	C	Ground cable yellow & green/L:1 m (39.37in)/ double OT M6	1		
Communication cable	D	Standard network cable black/L:1.5 m (59.06 in)/Double RJ45 Plug	1		
Back Plate	E	-	1		
Expansion Screw	G	M8*80 mm	4		
Screw	H	M5*16 mm	2		
Mounting Positioning Board	I	-	1		
RJ45 Water-proof Wiring Terminal	J	-	3		

3 Installation environment requirements

1. Ensure that the equipment is installed in a dry and well-ventilated environment.
2. The installation position must be away from direct sunlight and rain.
3. The installation position must be far away from fire sources.
4. The installation position must be far away from water sources such as taps, sewer pipes, and sprinklers to prevent water seepage.
5. Do not expose the equipment to flammable or explosive gas or smoke.
6. Humidity: <95%RH (non-condensing); Operating temperature: -15°C~+55°C.

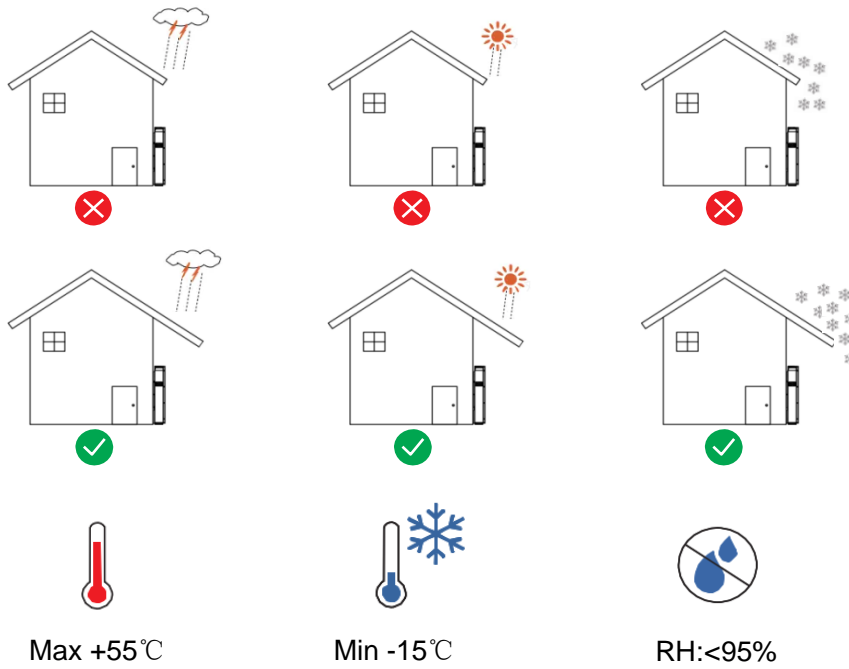

4 Product Appearance

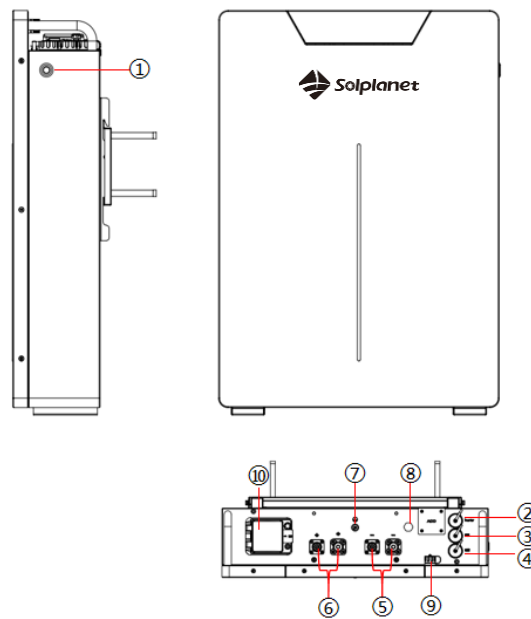

Number	Name	Details	Notes
1	Power Switch		Red light: ALM, Blue light: RUN
2	INVERTER	RJ45	CAN communication to the inverter
3	LINK IN	RJ45	Internal RS485 communication between batteries
4	LINK OUT	RJ45	Internal RS485 communication between batteries
5	Port Negative x2	PSR6XABM5A	Black cable 25 mm ² / 4 AWG, cable plug model: PSRP6XA25A
6	Port Positive x2	PSR6XCBM5A	Red cable 25 mm ² / 4 AWG, cable plug model: PSRP6XC25A
7	GND	M6	Yellow-Green, 10 AWG
8	Breather Valve		

9	WIFI Socket		For optional WIFI stick
10	125A DC Breaker		

RJ45 Port Pin Definition

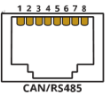
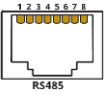
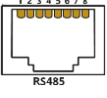
View	Item	Description	1	2	3	4	5	6	7	8
	2	INVERTER	-	RS485-A	RS485-B	CAN-H	CAN-L	GND	-	-
	3	LINK IN	-	BMS-RS485-A	BMS-RS485-B	DI+	DI-	-	BMS-CAN-H	BMS-CAN-L
	4	LINK OUT	-	BMS-RS485-A	BMS-RS485-B	DO+	DO-	-	BMS-CAN-H	BMS-CAN-L

5 Installation

5.1 Battery Installation

5.1.1

1. Measure the mounting space (position a cardboard the same size as the battery).
2. Mark the fixed position with the "mounting locating plate(I)".

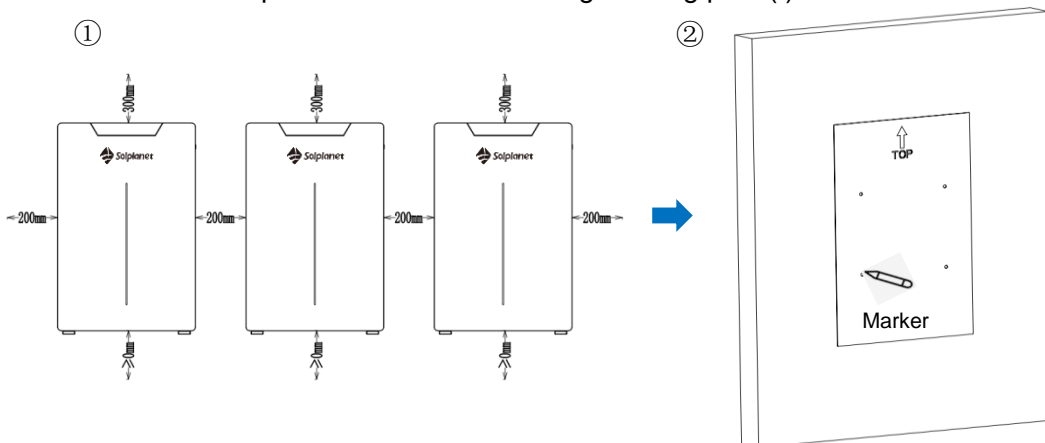

⚠ Note: Ensure that the mounting locating plate is level with the floor.

5.1.2

1. Use an impact electric drill to drill holes in the concrete or stone (fireproof) wall, the drilling depth is between 80mm and 85mm: The drill diameter is 12 mm.
2. Tighten the expansion bolt (G) slightly and put it into the hole. Knock the expansion bolt with a rubber hammer until all the expansion pipes enter into the hole.
3. Pre-tighten the expansion bolt.
4. Screw out the bolts and remove the spring washer and flat washer.

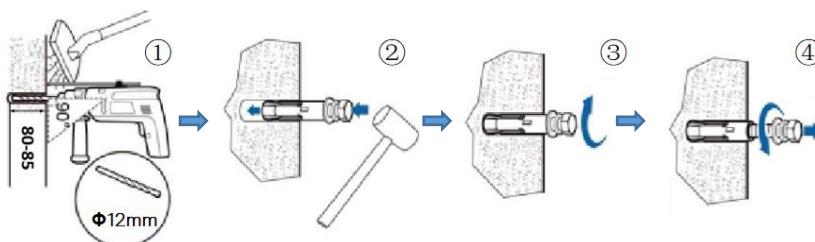

⚠ Note: Expansion bolts are mainly used for solid brick-concrete walls and concrete floors. If you choose other types of walls and floors, ensure that they meet the load-bearing requirements and select the bolts yourself.

5.1.3

1. Fix the "Back Plate (E)" to the wall.
2. Hang the battery on the bracket according to the picture below.
3. Secure the PACK from the side using screws (H).

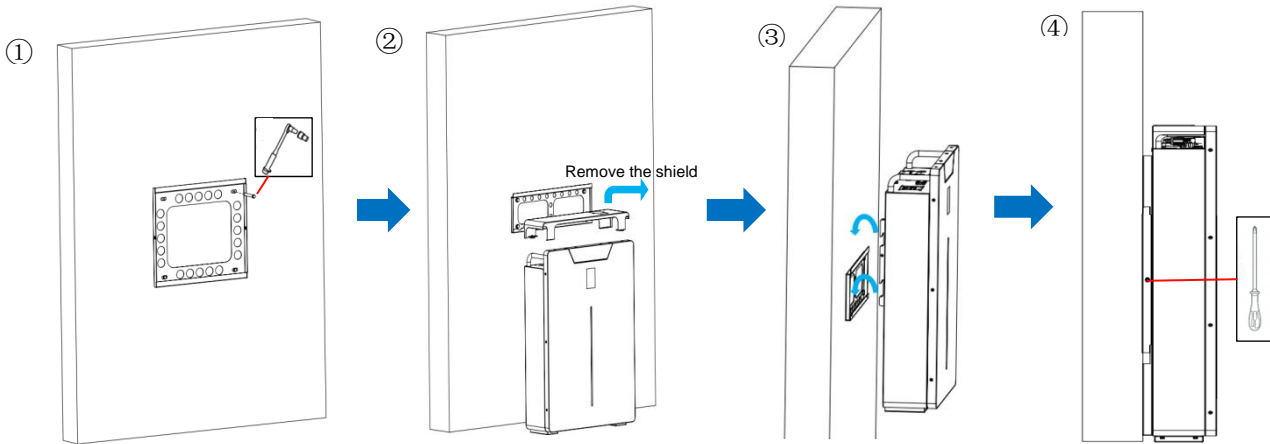

5.2 Single Unit Connection

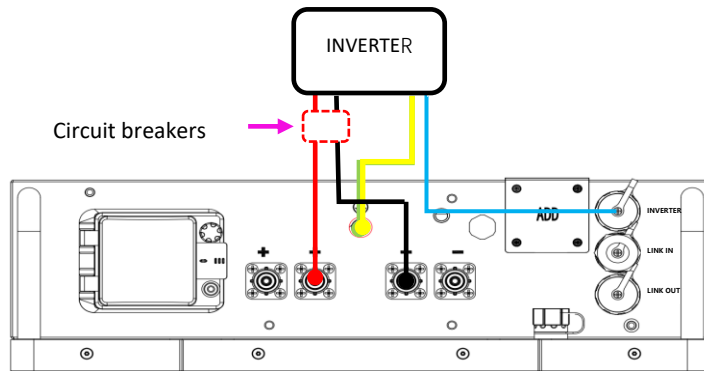

⚠ Note: Before electrical connection, ensure that the circuit breaker/power switch of the battery and all switches connected to the energy storage are in the OFF state. Otherwise, electric shock may occur.

1. The rated output power of the cable connection is 3 kW; SOC>70% The output power is 5 kW.
2. Install circuit breakers based on local regulations.

5.2.1 Ground Connection

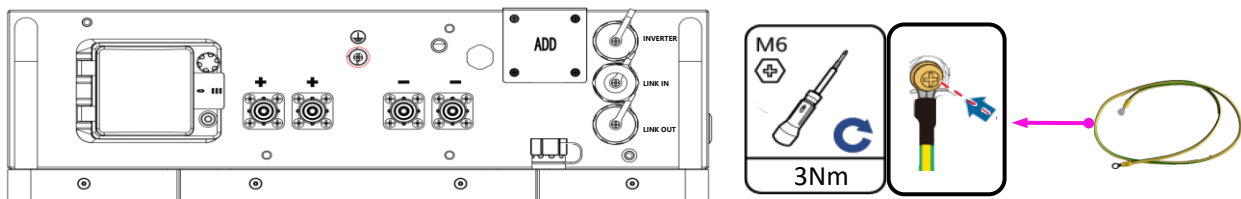

5.2.2 Communication Connection

1. Route the communications cable through the RJ45 cable cover (J) .
2. Connect the communications cable to the RJ45 port (marked "Inverter").
3. Tighten the RJ45 cable cover.
4. Connect the other end of the communication cable to the inverter.

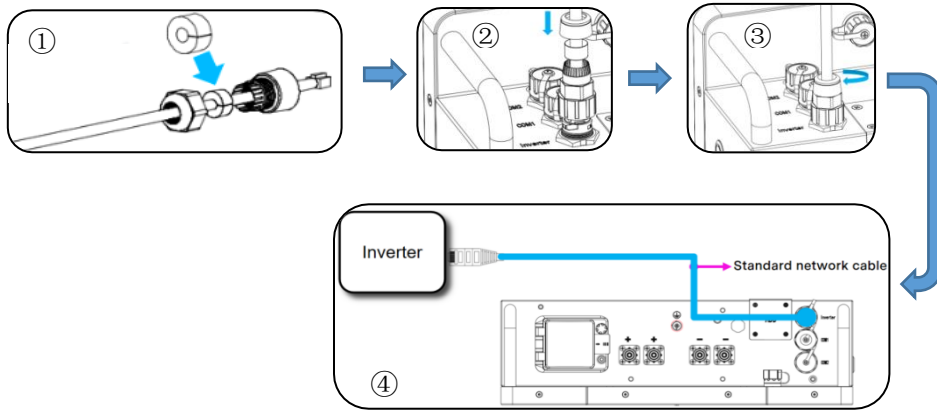

5.2.3 Power Cable Connection

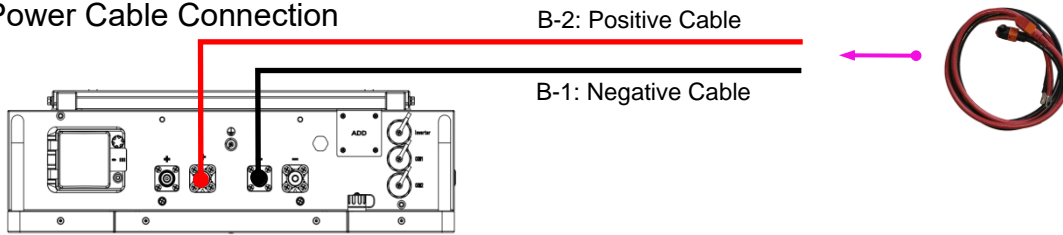

5.2.4 Activate Battery

1. Turn on the circuit breaker while the power switch is off.
2. Turn on Power Switch to start battery. After five seconds, a blue light flashes to indicate normal operation.
3. Cover with the front cover after checking.
4. Turn on any external DC circuit breaker between inverter and battery or parallel batteries.

NOTE:

State	Standby	Charge	Discharge	Failure
Light				
Remarks	Light 0.25 S / Lights out 3.75 S	Light 0.5 S / Lights out 0.5 S	Lights stay on	Flicker/Persist
	When the battery starts up, the red and blue lights alternately flash, indicating that the battery self-test is normal			

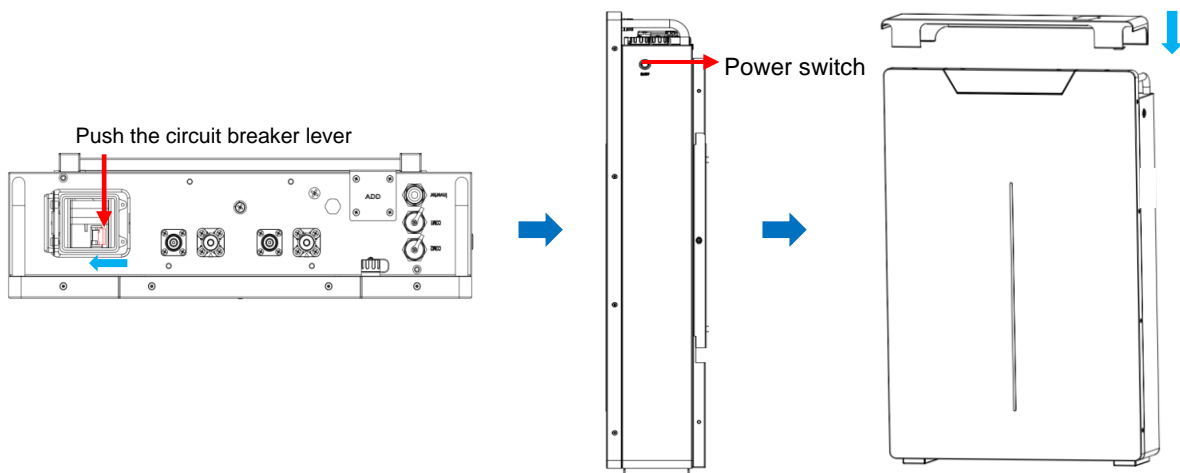

5.2.5 Shutdown Battery

1. Turn off Power Switch to shutdown battery.

2. Turn off any external DC circuit breaker between inverter and battery or parallel batteries.
3. Turn off the integrated circuit breaker.

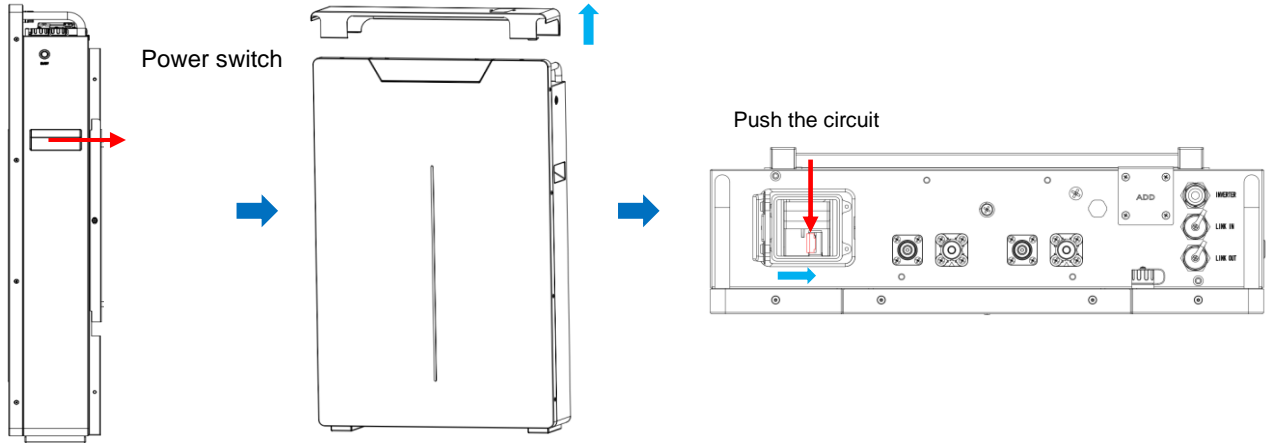

5.3 Multi-Unit Connection with Bus-Bars (3-Unit Example)

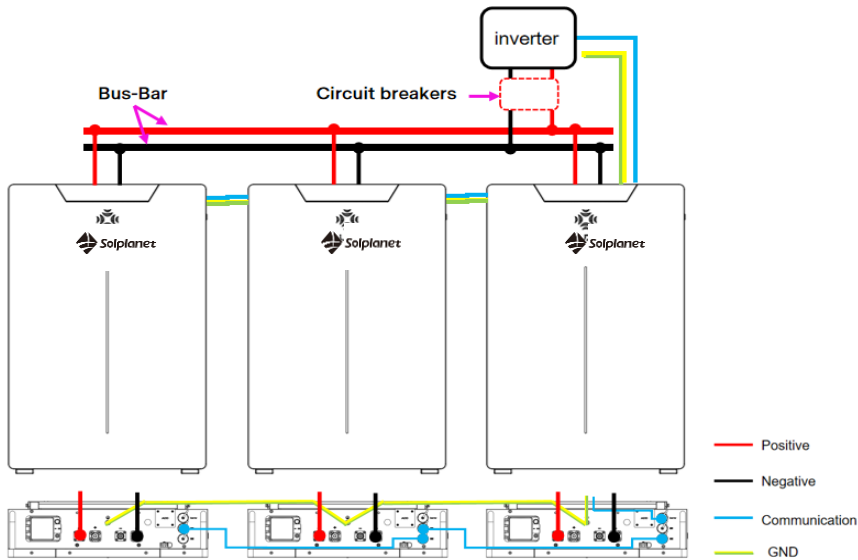

1. The method of cable connection with a bus-bar will output a power of $3 \times 3 \text{ kW} = 9 \text{ kW}$, and at a state-of-charge (SOC) over 70%, $3 \times 5 \text{ kW} = 15 \text{ kW}$.
2. Max. number of parallel units: 32. Note that the max. recommended charge and discharge power is 96 kW continuous and 160kW peak.
3. Install circuit breakers based on local regulations.

5.3.1 Ground Connection

Please follow step 5.2.1.

5.3.2 Parallel communication

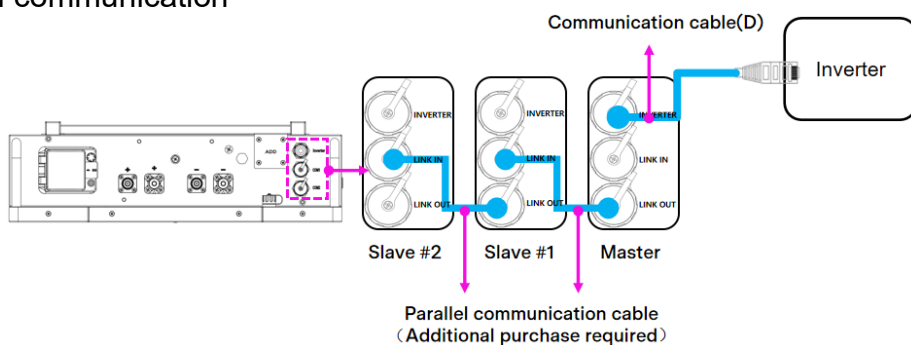

For details about communication wiring follow step 5.2.2.

5.3.3 Power Cable Connection

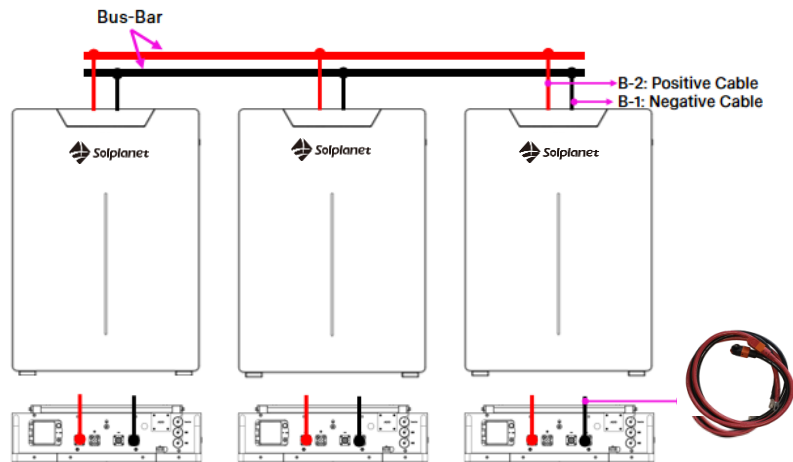

5.3.4 Activate Battery Bank

Please follow step 5.2.4. Make sure all breakers are turned on before pressing the power switches on all batteries.

5.4 Multi-Unit Connection without Bus-Bars (3-Unit Example)

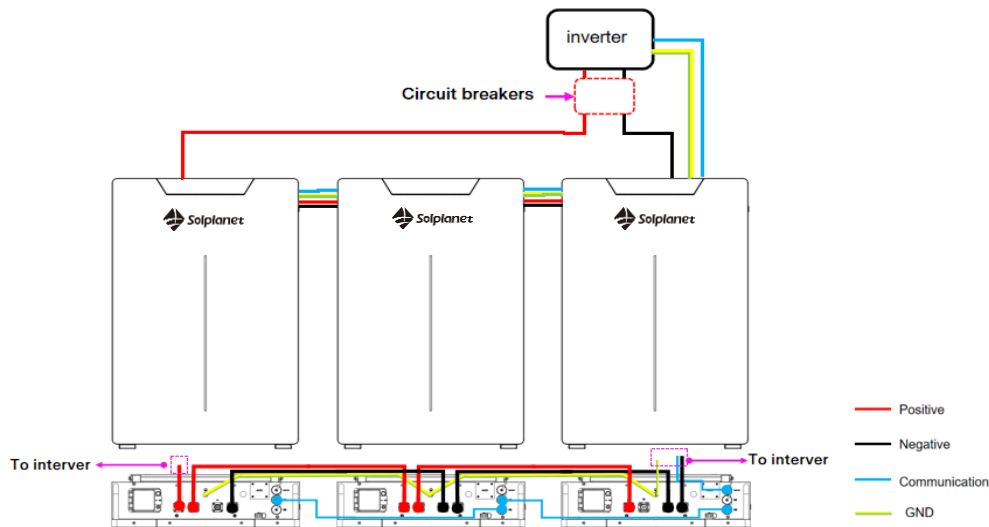

1. This wiring method will allow a max. power output of 5 kW continuous, limited by the wiring and connectors. Make sure the connected inverter does not exceed 5 kW/100 A continuous during both charge and discharge.

2. Install circuit breakers based on local regulations.

5.4.1 Ground Connection

Please follow step 5.2.1.

5.4.2 Communication Connection

Please follow step 5.2.2.

5.4.3 Power Cable Connection

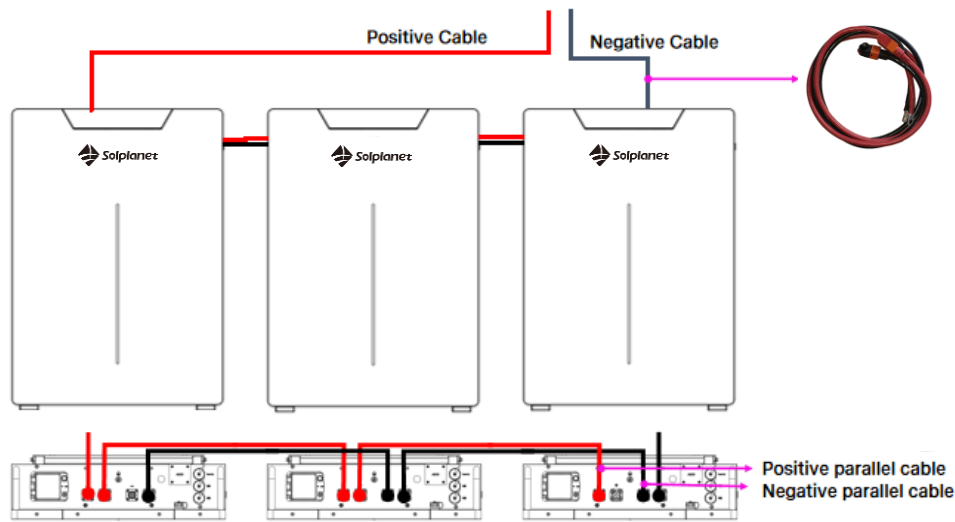

Note: Parallel cable needs to be purchased extra.

5.4.4 Activate Battery Bank

Please follow step 5.2.4. Make sure all breakers are turned on before pressing the power switches on all batteries.

6 Manufacturing Cables When Required

6.1 Power Cable

6.1.1 Material List (plug components may be purchased separately from supplier)



Plug sub assembly



Cable sealing ring



Plug protection cover

Steps:

Procedure	Schematic picture
1.Route the cable through the isolation cable sealing ring and Plug protection cover.	
2.Remove 13mm of insulation at end of cable.	
3.The red plug is used for the positive, and the black is for the negative power cable. The end of the cable is crimped at the terminal using a crimping clamp.	
4.Tighten the isolation cap and plug contact.	
5.Put the positive and negative plug on to the system and tighten them.	
6.Use isolation cap for unused DC plug.	

6.2 Communication Cable

6.2.1 Battery to Battery Communication Cable

Pin definition as below, alternatively a standard straight CAT 5 Ethernet cable can be used.

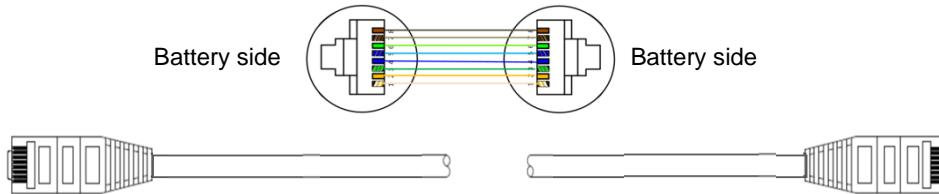

6.2.2 Battery to Inverter Communication Cable

Pin definition as below, check the pin definition for your inverter in the document linked in 5.2.2, point 4.

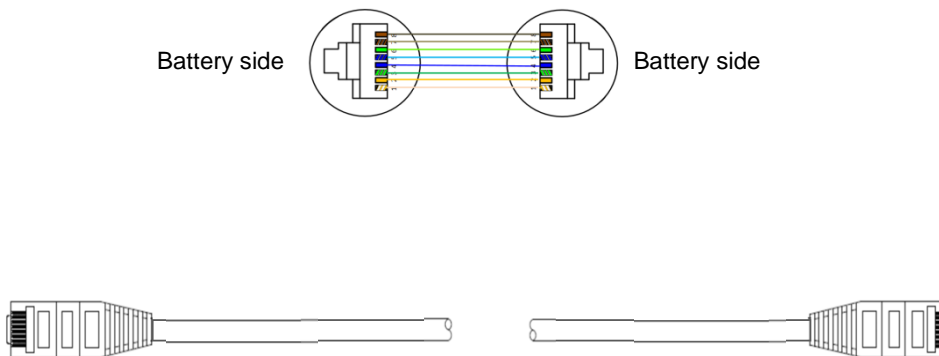

7 Other

Install an isolation device (i.e. a circuit breaker) between the inverter and the battery system to run both positive and negative conductor overcurrent protection. The steps for installing isolation devices (i.e. circuit breakers) are as follows:

1. Use E25-16 terminals to connect the wiring harness to the isolation device.
2. Insert the wiring harness terminal into the connection port of the isolation device, and distinguish the positive and negative terminals of the isolation device (see the isolation device specifications for details);
3. Tighten the wiring harness terminal with screws to secure it.

Note: During installation, please turn off the battery power switch and check whether the power is off. The cable from the circuit breaker to the inverter is provided by the installation personnel. (Please refer to the Product Packaging List for cable specifications)

8 Routine maintenance

To ensure the long-term running of the energy storage system (hereinafter referred to as “ the system”), you are advised to perform the following maintenance operations.

Check content	Maintenance method	Maintenance cycle
System cleaning	<ul style="list-style-type: none"> ● Check whether the appearance of the system is damaged or deformed. ● Clean the system. 	Once every six months to once a year.
System running state	<ul style="list-style-type: none"> ● Check whether there is abnormal sound during the operation of the system. 	Once every six months.

	<ul style="list-style-type: none"> ● Check whether indicator lights work normally. ● Check whether the system parameters are normal. ● Update software. 	
Electrical connection	<ul style="list-style-type: none"> ● Check whether the cable connection is loose. ● Check whether the cables are discolored. ● Check whether the cable is damaged, especially whether there is a cut mark on the surface of the cable in contact with the metal surface 	Half a year after the first commissioning, and once every half a year to a year thereafter.
Ground reliability	Check whether the ground cable is grounded reliably.	Half a year after the first commissioning, and once every half a year to a year thereafter.

9 Commissioning



The battery can operate together with Solplanet inverters as default. Monitoring of the battery status is available via the Solplanet App when installed with a Solplanet inverter. If the battery operate together with the other inverters, please contact Solplanet service.

If all of the items mentioned above have been met then proceed as follows to comission and start-up the battery for the first time:

Step 1: Turn the circuit breaker on the BCU to the “ON” position.

Step 2: Wait for the status LED to turn yellow, and press the ON/OFF button for 5s, and the BS will enter into working mode.

Step 3: Check whether the battery indicator of the inverter is on.

Step 4: Start inverter according to inverter start-up procedure.

Step 5: Commission the inverter according to the inverter commissioning procedure using the Solplanet App.