



# Single phase All-in-one hybrid energy storage system

## User Manual

ASW0600/1250A-S

ASW0800/1250A-S

ASW1000/1250A-S

ASW0600/2500A-S

ASW0800/2500A-S

ASW1000/2500A-S

## Contents

1	General information .....	3	9.1	Disconnecting the inverter from voltage sources.....	67
1.1	About this document.....	3	10	Technical data .....	69
1.2	Product validity.....	3	10.1	ASW 0600-1000/1250A-S.....	69
1.3	Target group.....	3	10.2	ASW 0600-1000/2500A-S .....	70
1.4	Symbols .....	4	10.3	General data .....	72
2	Safety.....	5	10.4	Protective device.....	73
2.1	Intended use .....	5	11	Troubleshooting .....	74
2.2	Important safety instructions.....	5	12	Maintenance .....	76
2.3	Symbols on the label.....	6	13	Recycling and disposal.....	77
3	Unpacking and storage.....	8	14	EU declaration of conformity .....	77
3.1	Scope of delivery .....	8	15	Service and warranty .....	77
3.2	Product storage .....	8	16	Contact.....	78
4	Inverter overview.....	9			
4.1	Product description.....	9			
4.2	Dimensions.....	9			
4.3	Display .....	10			
4.4	Interfaces and functions .....	12			
4.5	System solution .....	13			
4.6	Energy Management .....	20			
5	Mounting .....	24			
5.1	Requirements for mounting.....	24			
6	Electrical connection.....	26			
6.1	Connection port description .....	26			
6.2	Connecting additional grounding.....	26			
6.3	AC connection .....	27			
6.4	DC connection.....	32			
6.5	Communication equipment connection.....	39			
7	Commissioning and operating .....	42			
7.1	Inspection before commissioning .....	42			
7.2	Commissioning procedure.....	42			
7.3	Checking the operating status.....	42			
7.4	Configure the parameter on the screen .....	43			
8	Solplanet APP .....	45			
8.1	Brief introduction.....	45			
8.2	Download and install .....	45			
8.3	Create an account .....	45			
8.4	Create a plant .....	47			
8.5	Setting parameters .....	53			
9	Decommissioning the product .....	67			

# 1 General information

## 1.1 About this document

This document describes the mounting, installation, commissioning, configuration, operation, troubleshooting and decommissioning of the single phase All-in-one hybrid energy storage system (HESA).

You will find the latest version of this document and further information on the HESA in PDF format at [www.solplanet.net](http://www.solplanet.net).

It is recommended that this document be readily accessible at all times.

## 1.2 Product validity

This document is valid for the following models:

- ASW0600/1250A-S
- ASW0800/1250A-S
- ASW1000/1250A-S
  
- ASW0600/2500A-S
- ASW0800/2500A-S
- ASW1000/2500A-S

## 1.3 Target group

This document is intended for electricians and users who have basic safety knowledge about operating electrical equipment. However, installation personnel must be familiar with local requirements and regulations.

Users must possess the following skills:

- Know how the machine works and operates.
- Train how to deal with the hazards and risks associated with installing, repairing, and using electrical equipment and installations.
- Be aware of all applicable laws, standards and directives.
- Be aware of all applicable laws, standards and directives.

## 1.4 Symbols

### **DANGER**

Indicates a hazardous situation which, if not avoided, will result in death or serious injury.

### **WARNING**

Indicates a hazardous situation which, if not avoided, could result in death or serious injury.

### **CAUTION**

Indicates a hazardous situation which, if not avoided, could result in minor or moderate injury.

### **NOTICE**

Indicates a situation which, if not avoided, can result in property damage.



Information that is important for a specific topic or goal, however not related to safety.

## 2 Safety

### 2.1 Intended use

- The product is a All-in-one hybrid energy storage system with 2 MPP trackers and a internal battery connection that feeds the direct current of the PV array into the connected battery or converts it to grid-compliant single-phase current and then feeds it into the utility grid. The product also can convert the direct current supplied by the battery into grid-compliant single-phase current. The product has a backup function that can continue to supply the load with power from the battery or PV system in the event of a grid fault after the customer's inhouse main power switch is off.
- The product is intended for indoor applications. Do not use in outdoor applications.
- The product is equipped with an integrated high frequency transformer and therefore has galvanic isolation. The product should not be operated with PV modules which require functional grounding of either the positive or negative PV conductors.
- All components must remain within their permitted operating ranges and their installation requirements at all times.
- Use the product only in accordance with the information provided in the user manual and with the locally applicable standards and directives. Any other application may cause personal injury or damage to property.
- The product must only be used in countries for which it is approved by solplanet and the grid operator.
- The type label must be permanently attached to the product and must be in a legible condition.
- This document does not replace any regional, state, provincial, federal or national laws, regulations or standards that apply to the installation, electrical safety and use of the product.

### 2.2 Important safety instructions

The product has been designed and tested strictly according to the international safety requirements. As with all electrical or electronical devices, there are residual risks despite careful construction. To prevent personal injury and property damage and to ensure long-term operation of the product, read this section carefully and observe all safety information at all times.

#### **DANGER**

##### **Danger to life due to electric shock when touching live components in Off-Grid mode !**

Even if the AC breaker are disconnected, the parts of the system may still be live when the battery is switched on due to Off-Grid mode.

- Do not open the product.
- Disconnect the product from all voltage and energy sources and ensure it can not be reconnected before working on the product.

#### **DANGER**

##### **Danger to life due to fire or explosion when batteries are fully discharged !**

A fire may occur due to incorrect charging of fully discharged batteries. This can result in death or serious injury.

- Make sure that the battery is not fully discharged before commissioning the system.
- Contact the battery manufacturer for further proceedings if the battery is fully discharged.
- The battery in the product need be charged if the product has been stored more than half a year.

## **WARNING**

### **Danger to life due to electric shock from destruction of the measuring device due to overvoltage !**

Overvoltage can damage a measuring device and result in voltage being present in the enclosure of the measuring device. Touching the live enclosure of the measuring device results in death or lethal injuries due to electric shock.

- Only use measuring devices with the measurement range higher than the grid voltage.

## **WARNING**

### **Risk of burns due to high temperature !**

Some parts of the enclosure can become hot during operation.

- During operation, do not touch any parts other than the enclosure lid of the product.

## **WARNING**

### **Risk of injury due to weight of product !**

Injuries may result if the product is lifted incorrectly or dropped while being transported or mounted.

- Transport and lift the product carefully. Take the weight of the product into account.
- Wear suitable personal protective equipment for all work on the product.



### **The country grid code set must be set correctly !**

If you select a country grid code set which is not valid for your country and purpose, it can cause a disturbance in the PV system and lead to problems with the grid operator. When selecting the country grid code set, you must always observe the locally applicable standards and directives as well as the properties of the PV system (e.g., PV system size, grid-connection point).

- If you are not sure which standards and directives are valid for your country or purpose, contact the grid operator.

## 2.3 Symbols on the label



Beware of a danger zone!

This symbol indicates that the product must be additionally grounded if additional grounding or equipotential bonding is required at the installation site.



Beware of high voltage and operating current!

The product operates at a high voltage and current. Work on the product must only be carried out by skilled and authorized personnel.



Beware of hot surfaces!

The product can get hot during operation. Avoid contact during operation.



WEEE Designation

Do not dispose of the product together with household waste. Dispose the product in accordance with local disposal regulations for electronic waste



CE marking  
The product complies with the requirements of the applicable EU directives.



Certification mark  
The product has been tested by TÜV and obtained the quality certification mark.



CE marking  
The product complies with the requirements of the applicable EU directives.



Capacitor discharge  
Danger to life due to high voltages in the inverter. Do not touch live parts for 5 minutes after disconnection from the power sources.



Observe the documentation  
Read and understand all documentation supplied with the product.

---

## 3 Unpacking and storage

### 3.1 Scope of delivery

Check the scope of delivery for completeness and any visible external damage. Contact your distributor if the scope of delivery is incomplete or damaged.

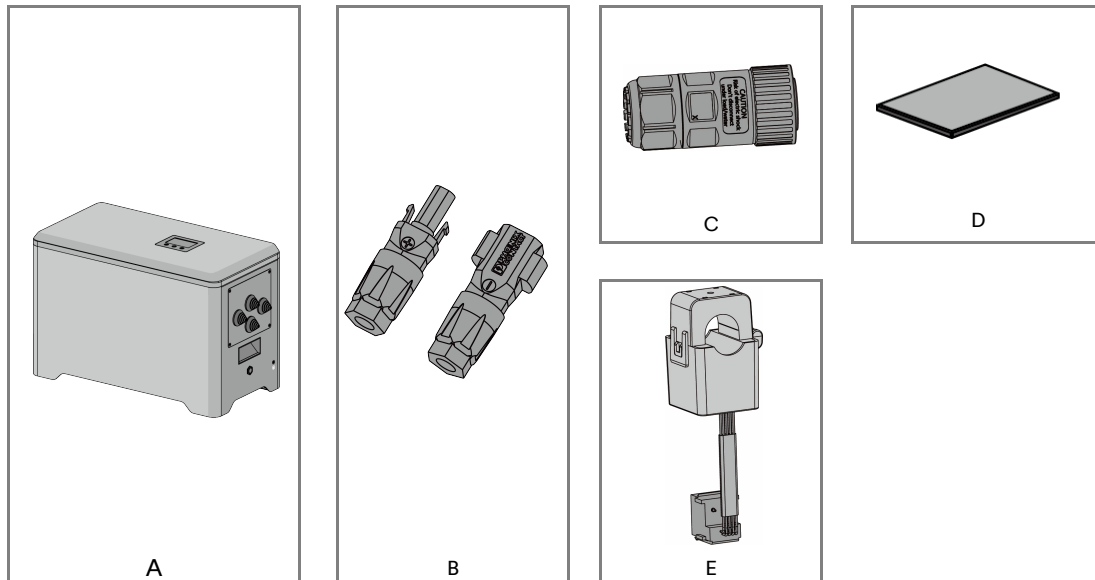

Object	Description	Quantity
A	All-in-one system	1
B	DC connector	4
C	AC connector	1
D	Document	1
E	External CT	1

### 3.2 Product storage

Suitable storage is required if the inverter is not installed immediately:

- Store the HESA in the original packing case.
- The storage temperature must be between  $-15^{\circ}\text{C}$  to  $+55^{\circ}\text{C}$ , and the storage relative humidity must be between 0 and 95%, non-condensing.
- The packing with the product shall not be tilted or inverted.
- The product must be fully inspected and tested by professionals before it can be put into operation, if it has been stored for half a year or more.



## 4 Inverter overview

### 4.1 Product description

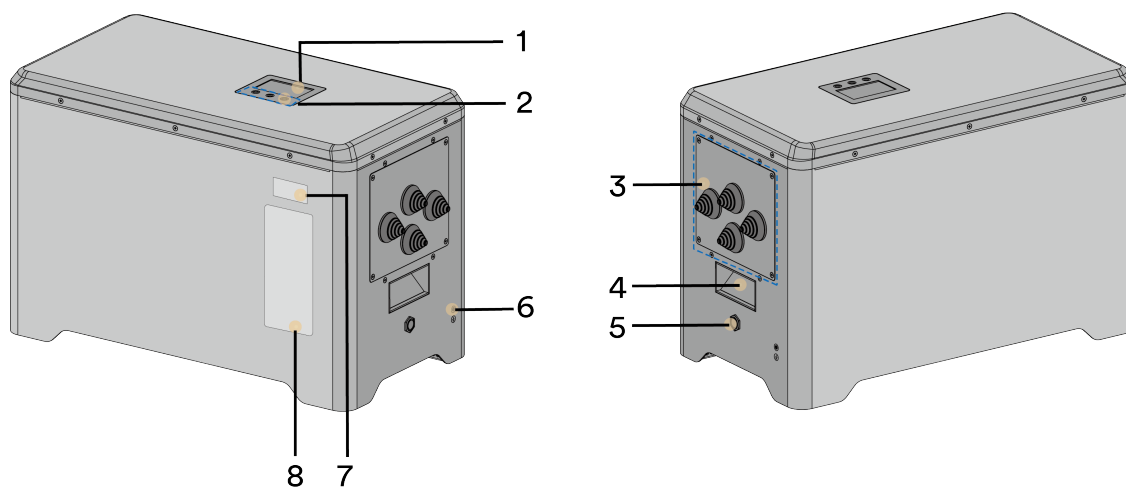
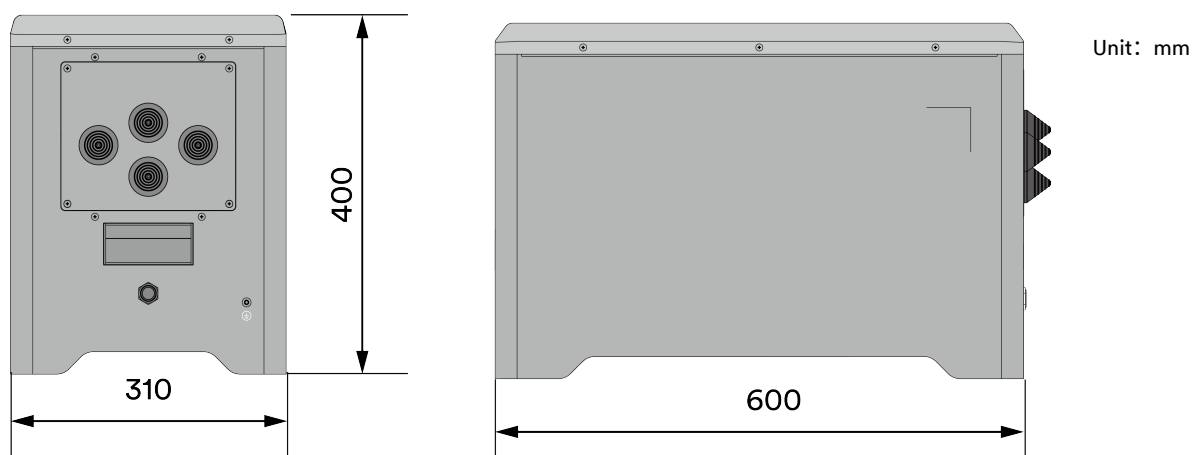

Figure shown here is for reference only. The actual product received may differ!

Object	Description
1	Display screen
2	Button area
3	Wiring area
4	Handle
5	Battery button
6	Secondary grounding wire screw
7	Ai-Dongle QR code
8	Labels

### 4.2 Dimensions



## 4.3 Display

The information provided here includes the operating parameters of all single phase All-in-one hybrid energy storage system.

### 4.3.1 Overview of the panel

The machine is equipped with 1 display screen and 3 keys.

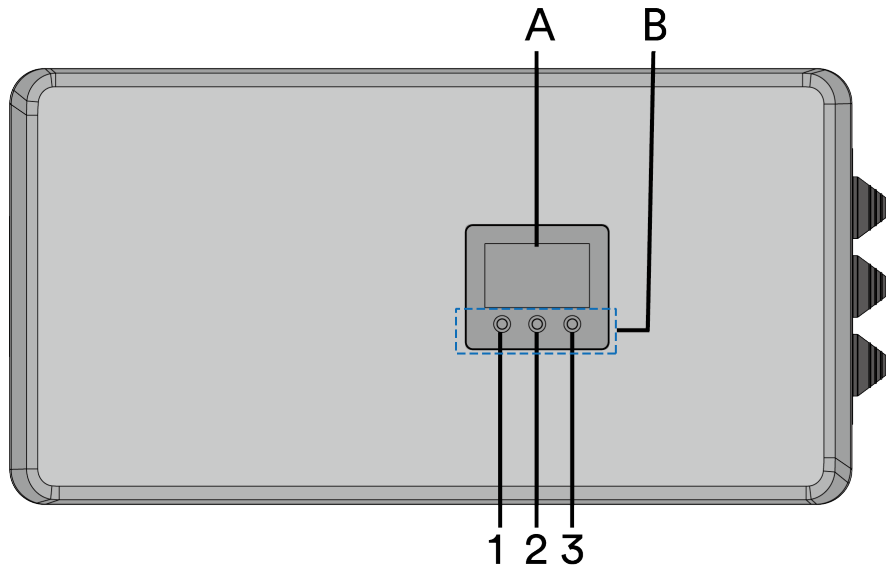

Area	Mark	NAME	Function
A DISPLAY	/	/	Alarm, set parameters, and working status display. See below.
B KEY	1	UP	Adjust parameter selection or parameter value upward.
	2	DOWN	Adjust parameter selection or parameter value downward.
	3	HOME	Click the HOME button to go to the next level menu, or toggle parameter options and parameter values. Press the HOME button for 2 seconds to return to the upper-level menu.

### 4.3.2 Screen

The information provided here includes the operating parameters of all single phase All-in-one hybrid energy storage system.

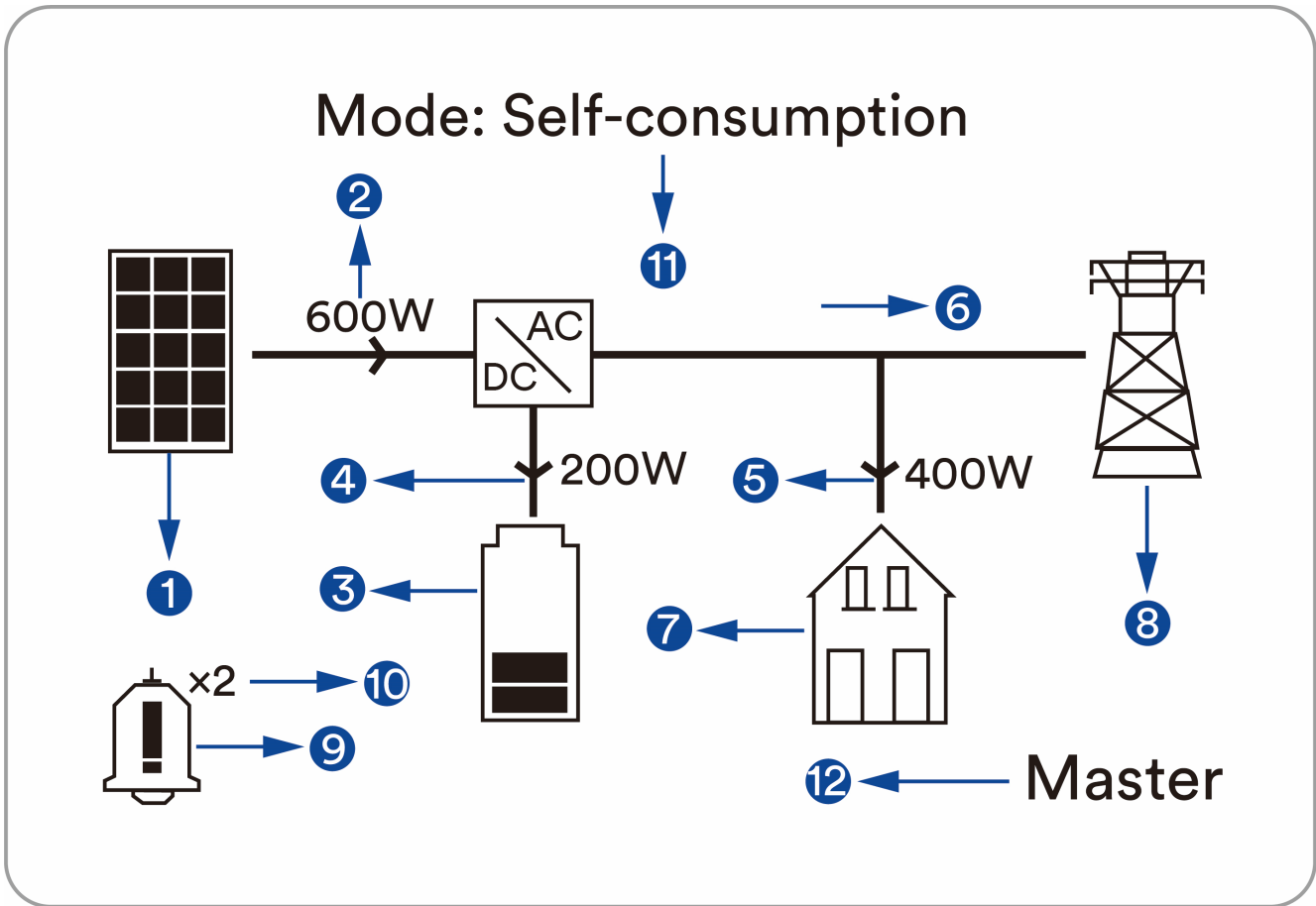

Object	Description
1	PV strings model.
2	Output power of PV strings.
3	The SOC information of the battery, 5 cells of charge represents 100% SOC.
4	Battery charging and discharging power values, the arrow up means discharge, and vice versa, charge.
5	The power value of the household load from the machine.
6	Power value, the arrow to the right indicates that power flows to the grid, and vice versa indicates that power is taken from the grid.
7	Household load.
8	Utility grid.
9	Error or warning information.
10	Number of alarms.
11	Current operation mode.
12	The current state of the machine in parallel mode, there are two kinds: master or slave. It is displayed only when the anti-reflux function is enabled on multiple machines. Master is displayed on the host, slave is displayed on the slave

## 4.4 Interfaces and functions

The product is equipped with the following interfaces and functions:

### **Ai-Dongle**

The product is equipped with an Ai-Dongle as standard, which provides a user interface for configuring and monitoring the product. The Ai-Dongle can connect to the Internet via WLAN.

### **RS485 Interface**

The product is equipped with two external RS485 interfaces, RS485-1 and RS485-2. The RS485 interfaces are connected through RJ45 ports.

The RS485 interfaces are reserved and you do not need to connect cables.

### **Current transformer (CT) interface**

The CT is connected to the HESA through the RJ45 port (see section 6.5.1). The HESA is equipped with a CT. In the self-consumption mode, the user needs to connect the CT to achieve the anti-reflux function. You can configure network cables to connect to the CT and the HESA based on your needs.

### **CAN (Controller Area Network) Interface**

The product is equipped with two external CAN interfaces and one internal CAN interfaces. The CAN interfaces are connected through RJ45 ports.

CAN-1 and CAN-2 ports (see section 6.5.1): When the user sets the machine to enter the Parallel Off-grid mode or 3-phase Off-grid mode, it is necessary to connect the external CAN communication interfaces of multiple machines(see section 4.5.2). Multiple machines communicate via the external CAN interfaces.

An internal CAN port is used to communicate with a Battery Management System (BMS). The internal CAN port has been connected.

### **USB Interface**

USB port is used to quickly upgrade programs via USB flash drive.

## 4.5 System solution

### 4.5.1 System solution

The single phase All-in-one hybrid energy storage system is composed of the following parts.

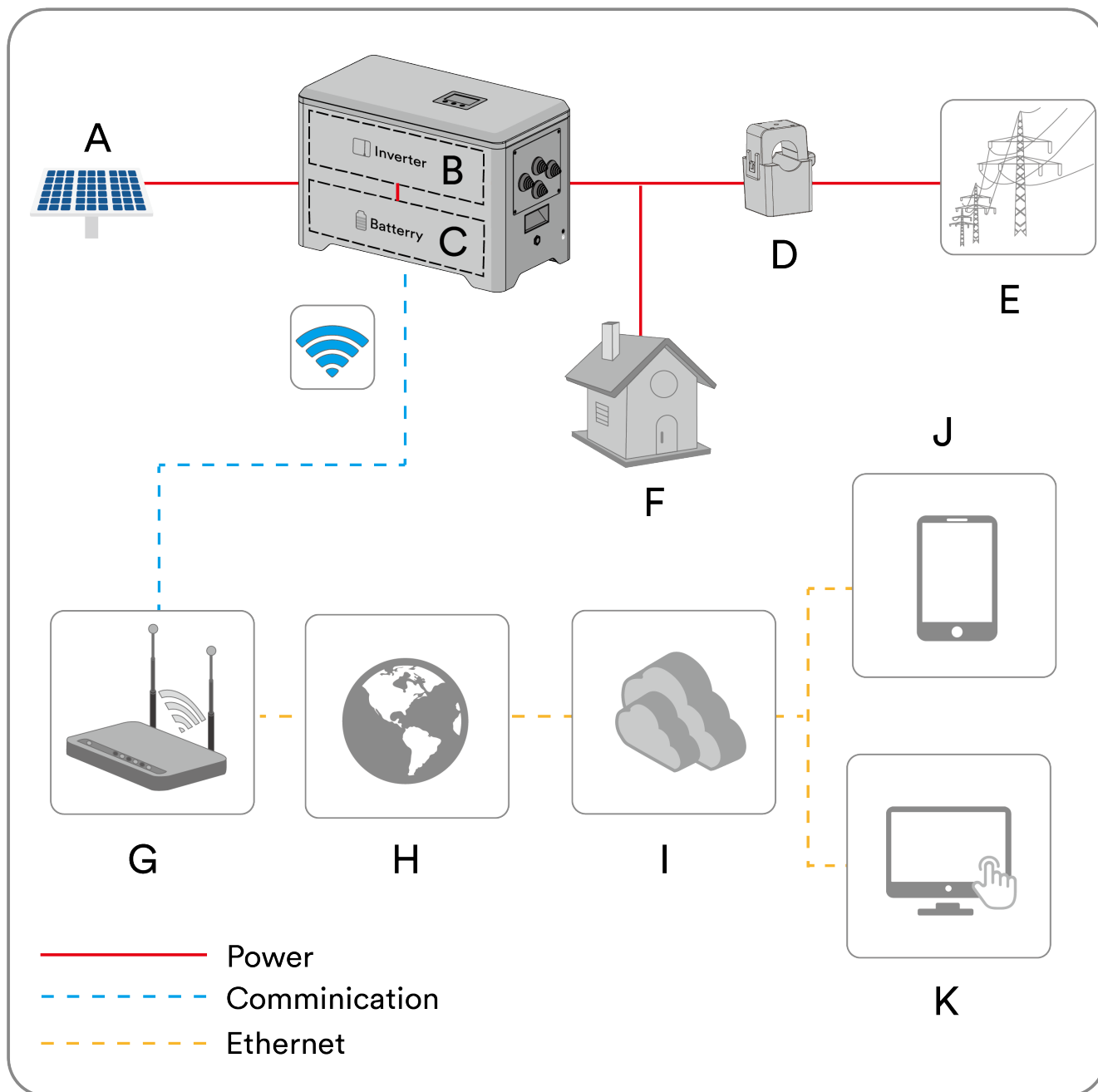

Object	Description	Remark
A	PV module	Supports to connect monocrystalline silicon module, polycrystalline silicon module, and thin-film module without grounding.
B	Inverter	Energy conversion (HESA).
C	Battery	Energy storage (Inside of HESA).

D	Current transformer (CT)	Measure the current and use for energy management.
E	Utility grid	The product can connect to TN and TT grounding system grid.
F	Load	General electrical equipment or EPS.
G	Router	The product can connect to router through Wi-Fi signal.
H	Internet	The monitor information can transfer to Cloud Server through Internet.
I	Cloud server	The monitor information is stored at cloud server.
J	Smart phone	The APP can be installed on the smart phone and then review the monitor information.
K	Computer	The monitor information also can be review on the computer.

#### 4.5.2 System wiring diagram

The wiring diagram of a single device with the single phase grid in Europe is shown in Figure 1.

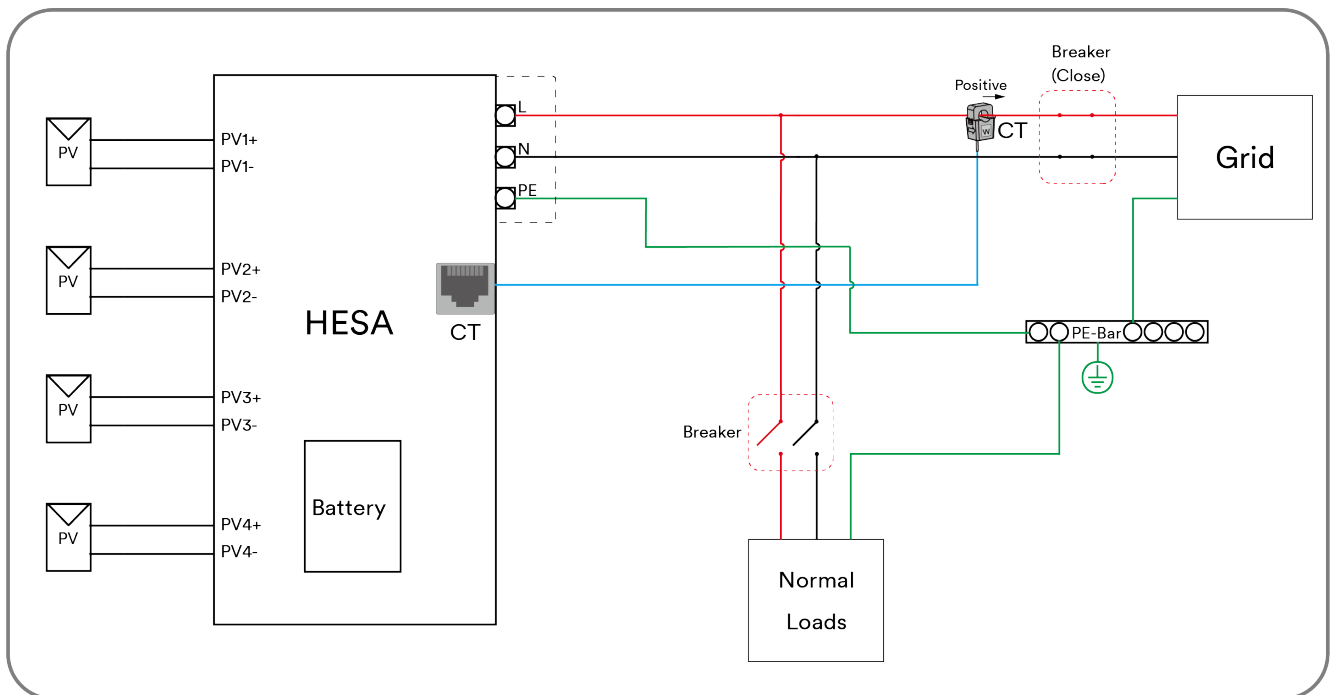

Figure 1



In self-consumption mode, users need to connect the CT according to the Figure 1, and ensure that the arrow on the CT points to the power grid. Otherwise the HESA will not work properly.

The wiring diagram of multiple devices with the single phase grid in Europe is shown in Figure 2.

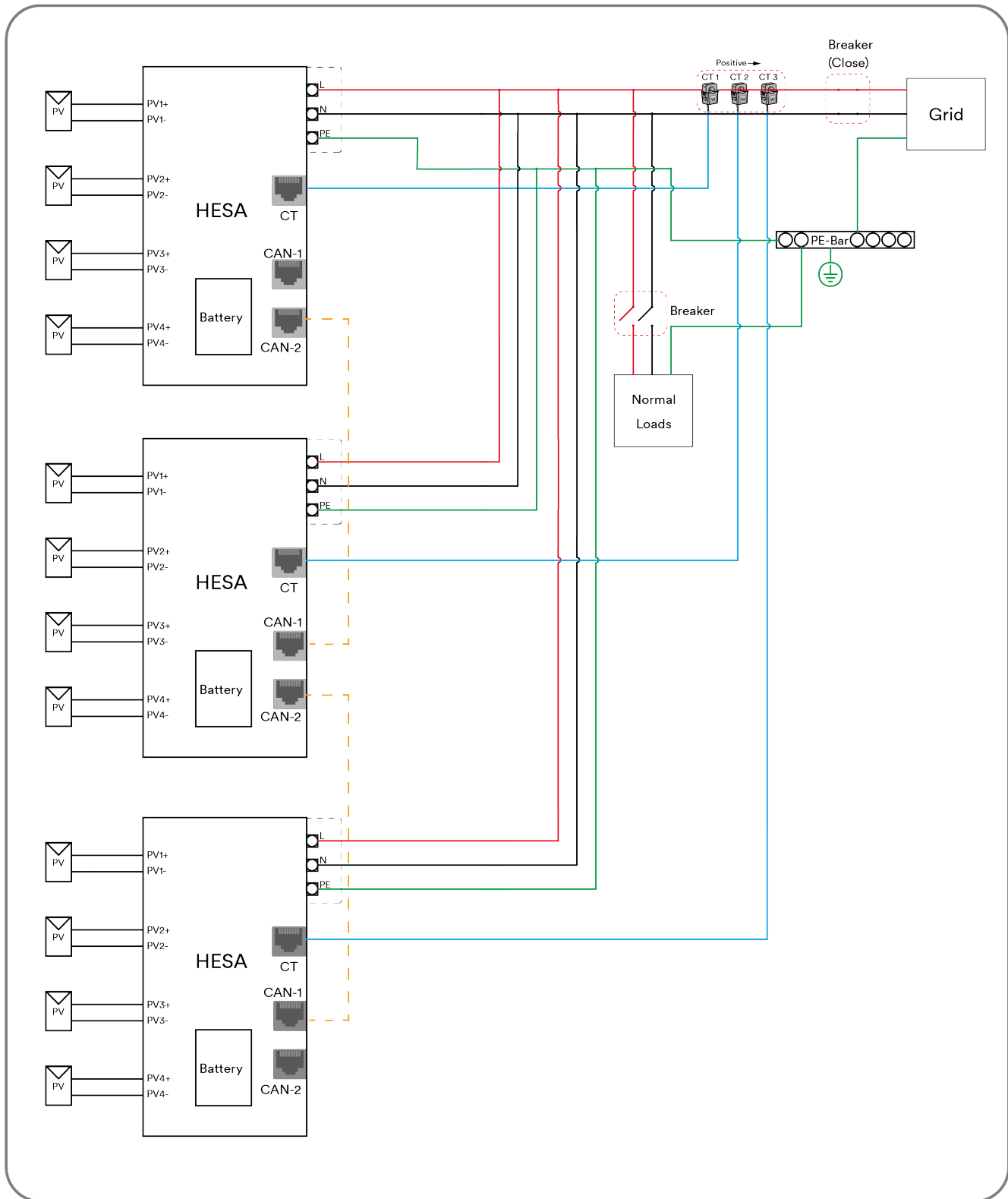

Figure 2



Users need to connect the CT correctly according to the Figure 2. CAN communication lines between multiple machines are not required.

The wiring diagram of multiple devices with the three-phase grid in Europe is shown in Figure 3.

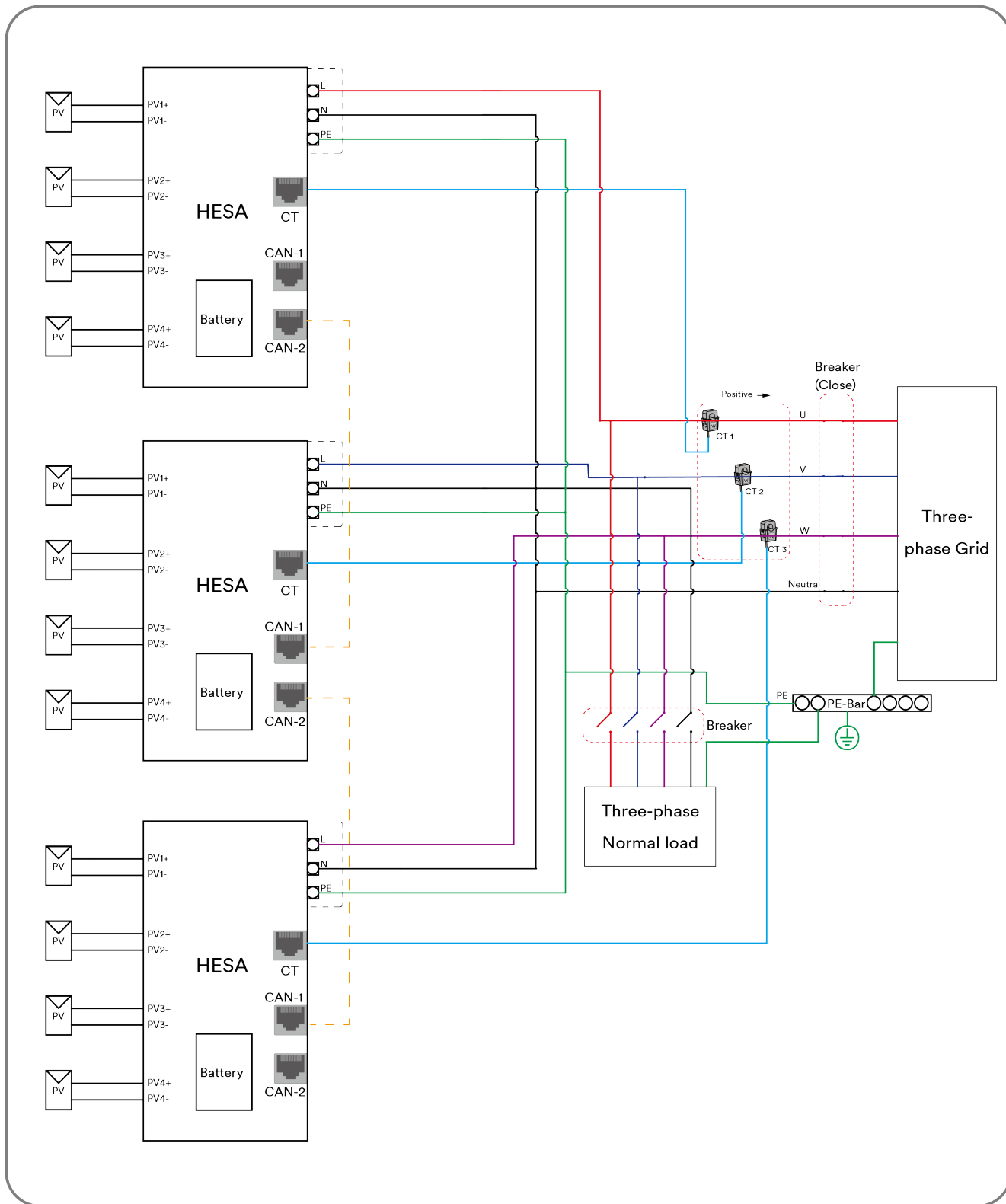

Figure 3



Users need to connect the CT correctly according to the Figure 3. CAN communication lines between multiple machines are not required.



The Off-grid mode wiring diagram of a single device is shown in Figure 4.

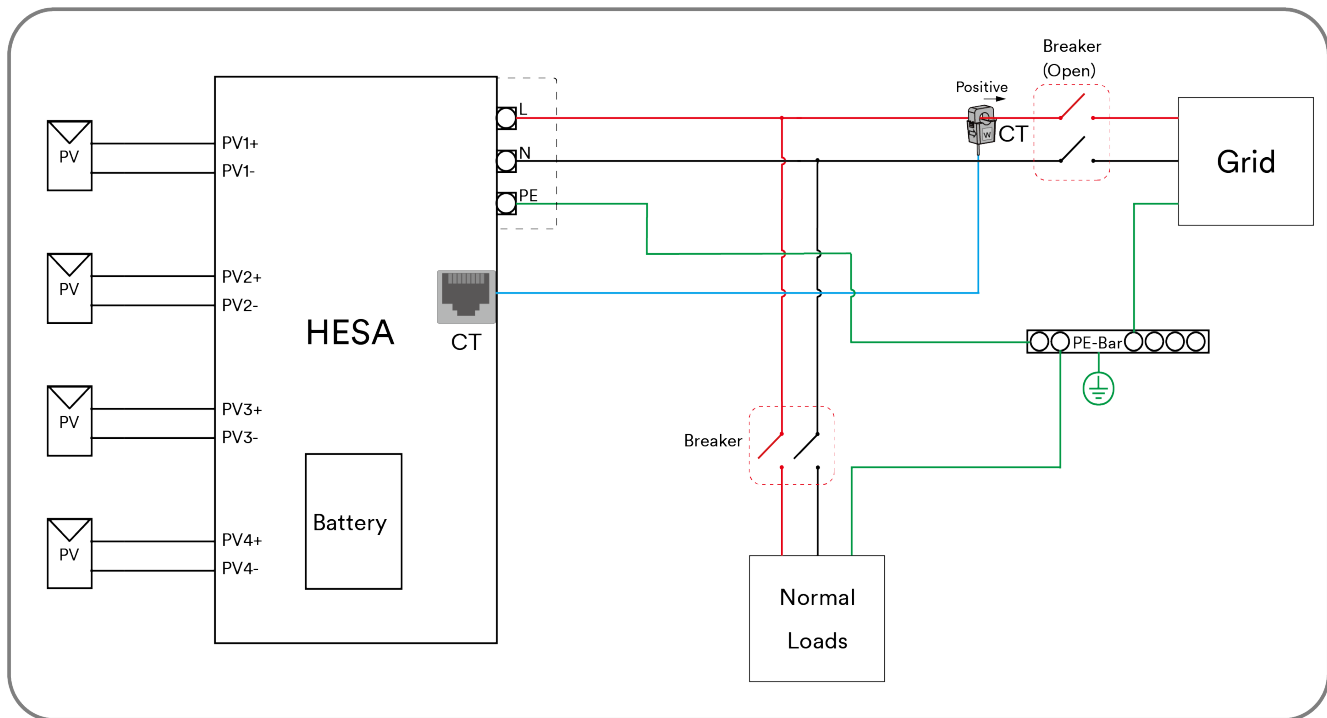

Figure 4



Before setting the HESA to work in Off-grid mode, users need to disconnect the circuit breaker on the grid side to prevent impact on the HESA when the power grid is restored. Otherwise, the machine may report an error or warning. When the HESA is operating in Off-grid mode, the circuit breaker on the grid side needs to remain disconnected.

The Parallel Off-grid mode wiring diagram of multiple devices is shown in Figure 5.(up to three devices in Parallel Off-grid mode)

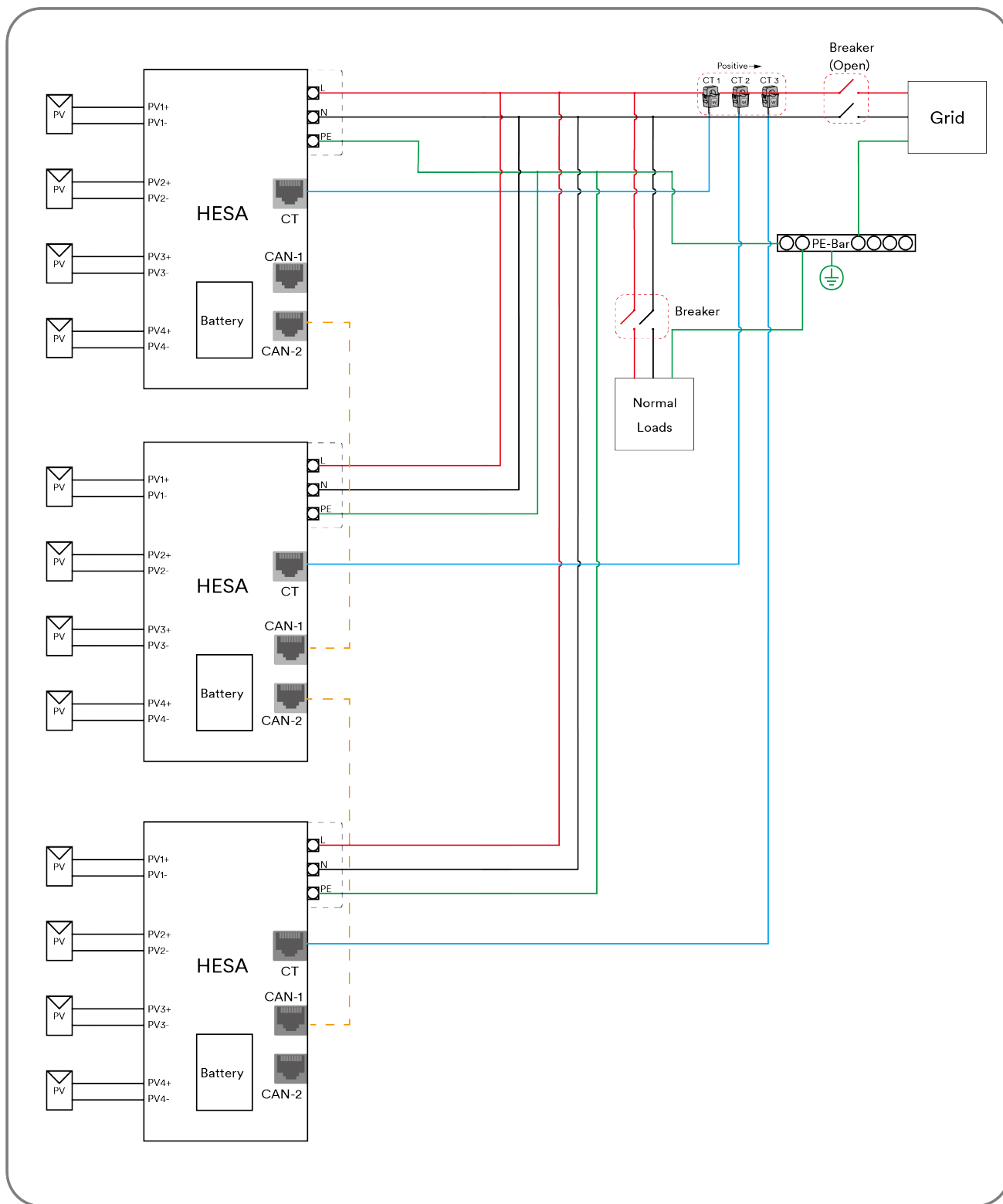

Figure 5



Before setting the HESAs to work in Parallel Off-grid mode, users need to disconnect the circuit breaker on the grid side to prevent impact on the HESAs when the power grid is restored. Otherwise, the devices may report an error or warning. When the HESAs are operating in Parallel Off-grid mode, the circuit breaker on the grid side needs to remain disconnected. In this mode, the CAN communication lines between multiple devices must be connected.

The 3-phase Off-grid mode wiring diagram of three devices is shown in Figure 6.

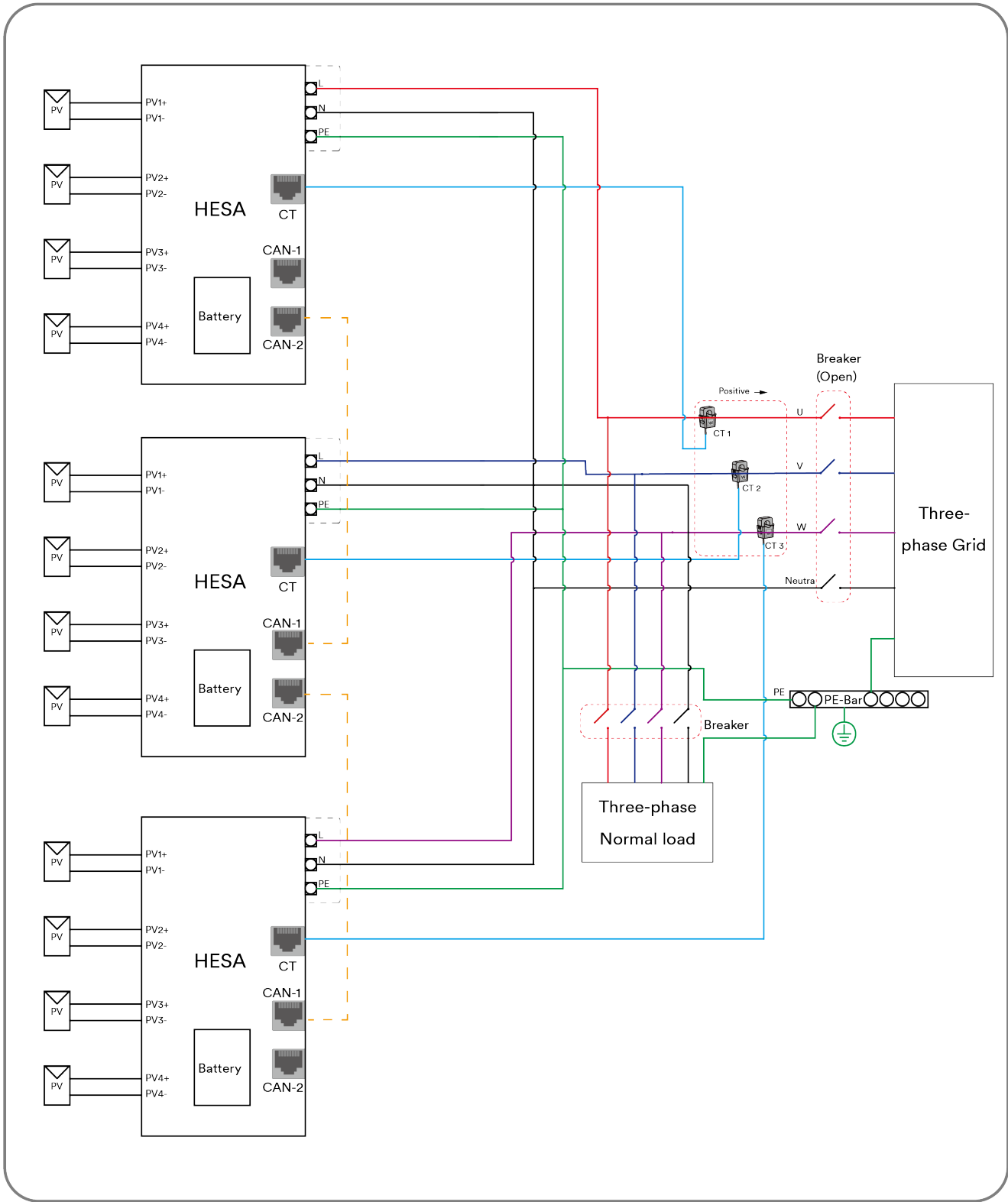

Figure 6



Before setting the HESAs to work in 3-phase Off-grid mode, users need to disconnect the circuit breaker on the grid side to prevent impact on the HESAs when the power grid is restored. Otherwise, the devices may report an error or warning. When the HESAs are operating in 3-phase Off-grid mode, the circuit breaker on the grid side needs to remain disconnected. In this mode, the CAN communication lines between multiple devices must be connected.

## 4.6 Energy Management

Single phase All-in-one hybrid energy storage system has six operating modes, self-consumption mode, simple mode, custom mode, Off-grid mode, Parallel Off-grid mode and 3-phase Off-grid mode. Users can set different working modes through the LCD display or APP.

### Self-Consumption mode

The photovoltaic energy is preferentially used by local load to improve the self-consumption rate and self-sufficiency rate.

The energy management during daytime:

Case 1: PV power generation is lower than the load power consumption, and the energy of the battery is not available.

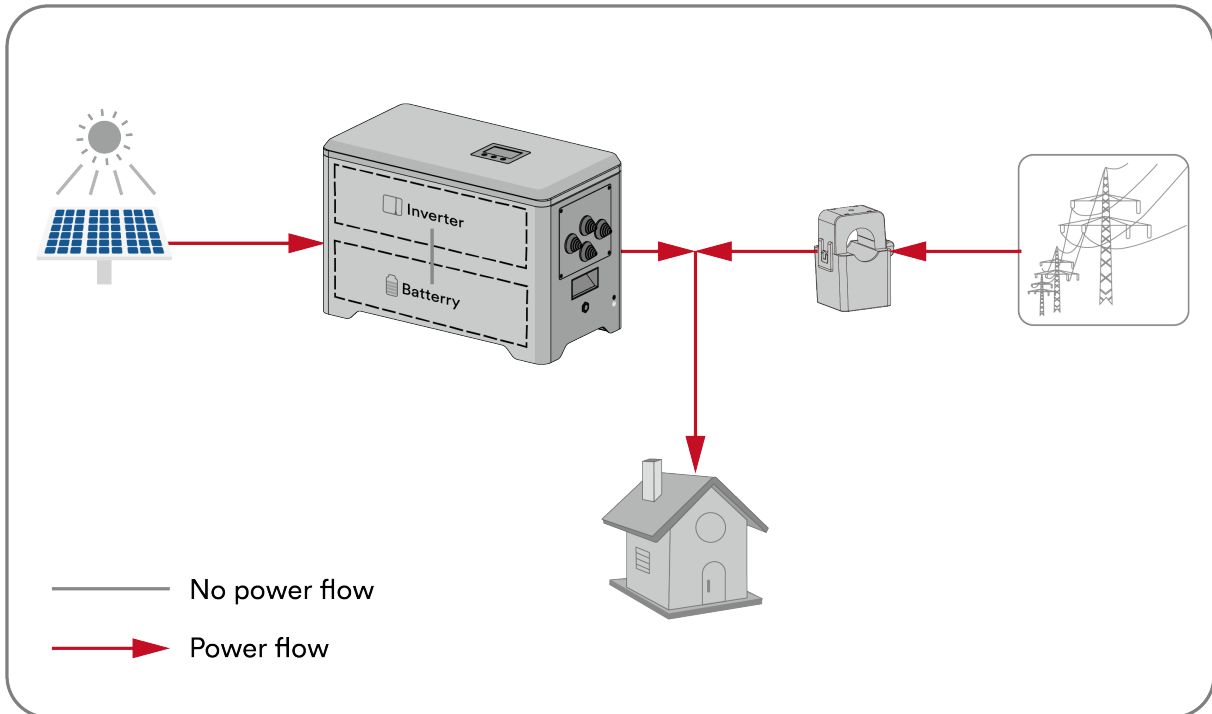

Case 2: PV power generation is lower than the load power consumption, and the energy of the battery is available.

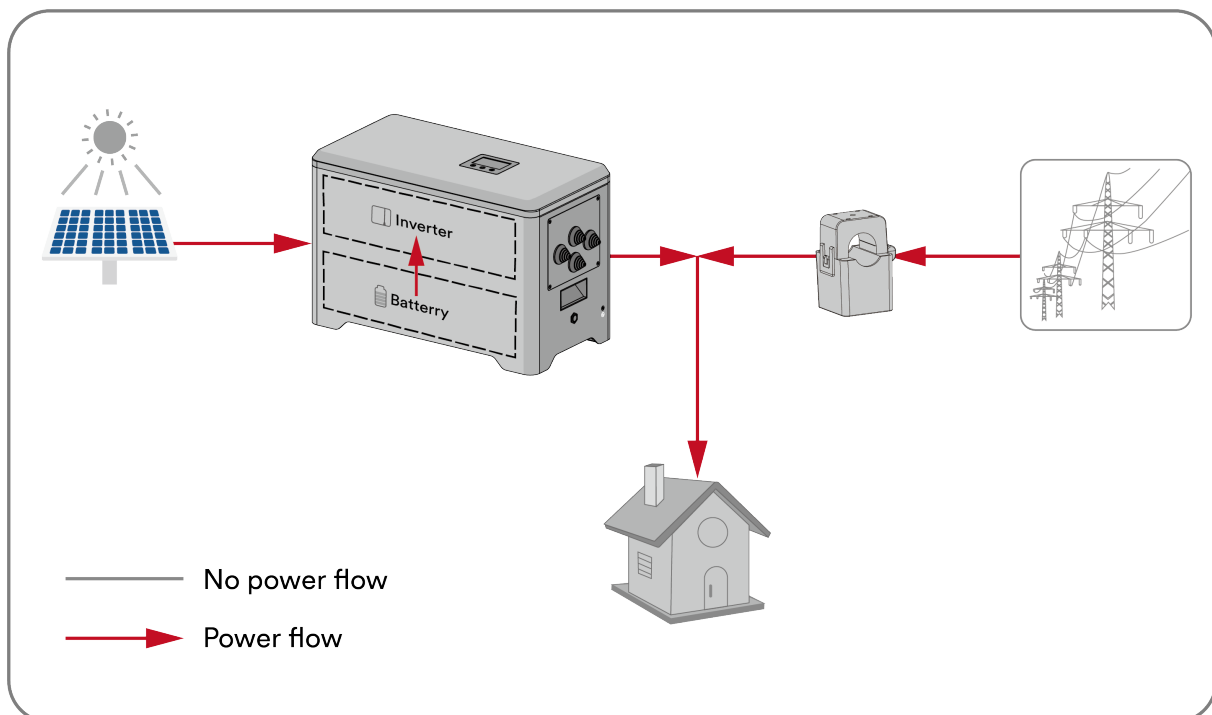

Case 3: PV power generation is larger than the load power consumption.

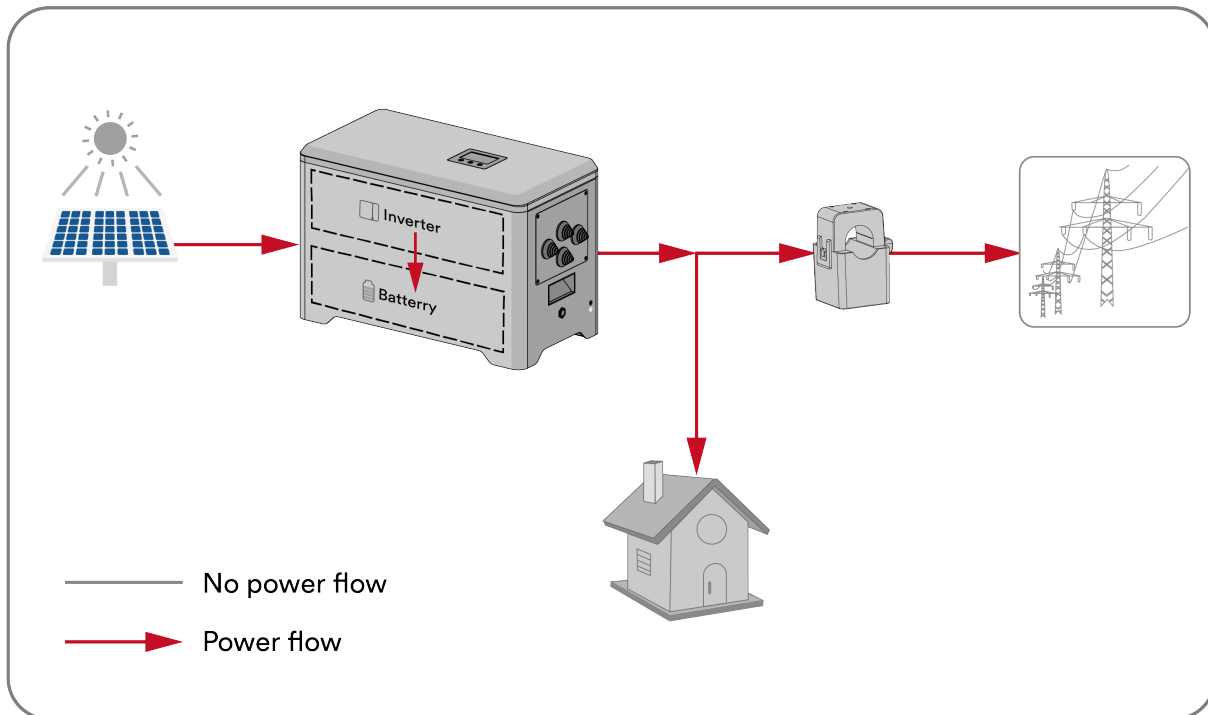

The energy management during night:

Case 1: The energy of the battery is available.

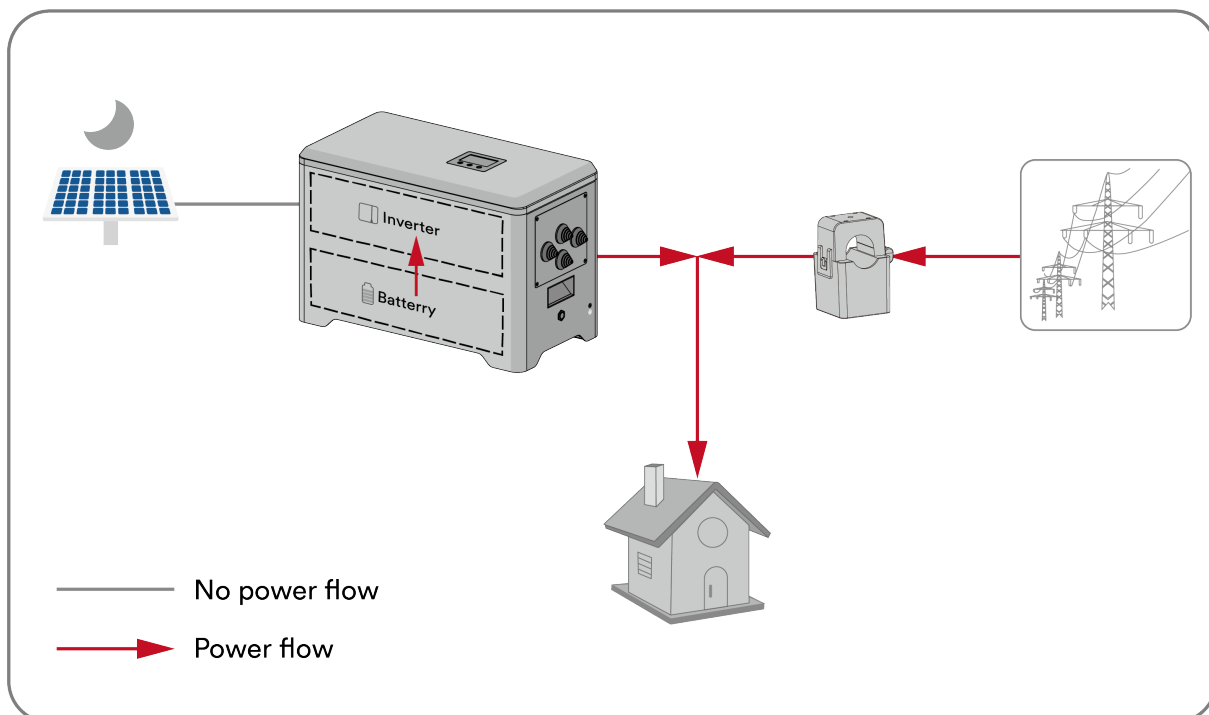

Case 2: The energy of the battery is not available.

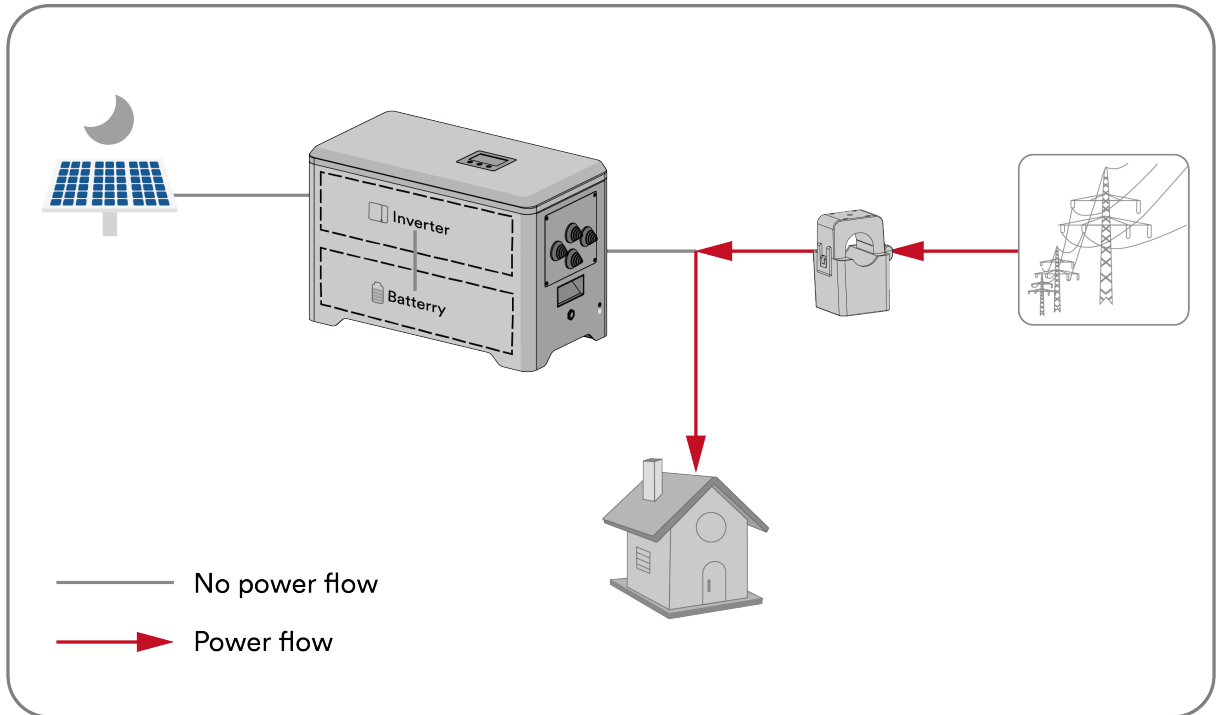

### Simple mode

In some cases, users don't need CT sensors and can achieve convenient and economical energy management solutions by simply setting the parameters of the all-in-one machine.

The user can set the upper and lower SOC values of the battery through the APP (see the chapter on APP Usage for details) (the default value for the upper SOC is 100%, the lower SOC is 10%), the battery discharge time range (the default value is 18:00 PM to 22:00 PM) and the battery discharge power on the LCD screen.

There are two discharge modes for customers to choose. The default mode is "Automatic", in this mode the discharge power is automatically calculated by the machine. The other mode is "Fix", in this mode the user can manually set the discharge power from 0 to Pmax W (Depending on the device model and capacity for example ASW0600/1250A-S has a 600W capacity).

### Custom mode

Users can manage the energy according to their own needs, and set the daily regular charging and discharging on the app. In the charge and discharge time band, the machine runs at rated power. Outside the charge and discharge time band, the machine works in self-consumption mode by default.

### Off-grid mode

When the power grid fails or the output is abnormal, the user can set the machine to enter the Off-grid mode (via APP or LCD). In this mode, the machine continuously outputs voltage for emergency load use even when there is no grid. However, it should be noted that the working load should not exceed the rated maximum power value of the machine at this time, otherwise the machine will stop working and report EPS Overload warning. In this case, the user needs to reduce the load and the machine can resume normal work.

Before entering the Off-grid mode, disconnect the circuit breaker connected to the power grid to prevent impact on the machine when the power grid is restored. After the circuit breaker is disconnected, set the machine to work in Off-grid mode.

Before exiting the Off-grid mode and entering another working mode, ensure that the circuit breaker connected to the power grid is off, set the machine to work in another mode, and finally close the circuit breaker connected to the power grid. When the machine detects that the power grid is back to normal, it will work normally again.

### **Parallel Off-grid mode**

In order to improve the load capacity in Off-grid mode, the user can set the machine to work in Parallel Off-grid mode (via APP or LCD). Before the user sets the mode, the user needs to connect the power output line and communication line of multiple machines respectively according to Figure 5(in 4.5.2 System wiring diagram), otherwise the machine cannot work normally. In Parallel Off-grid mode, each machine establishes communication through CAN, and the output power of multiple machines is equally distributed to meet the load requirements. The Parallel Off-grid mode supports a maximum of three parallel machines.

### **3-phase Off-grid mode**

When the user needs to carry three-phase load in off-grid mode, the machine can be set to enter the 3-phase Off-grid mode (via APP or LCD). Before the user sets the mode, the user needs to connect the power output line and communication line of multiple machines respectively according to Figure 6(in 4.5.2 System wiring diagram), otherwise the machine cannot work normally. In addition, the user needs to manually set the phase sequence U, V, and W of the three machines on the APP or LCD, and the system can work normally after the setting is completed. In off-grid three-phase networking mode, three machines communicate through CAN.

## 5 Mounting

### 5.1 Requirements for mounting

#### **DANGER**

Danger to life due to fire or explosion !

Despite careful construction, electrical devices can cause fires.

- Do not mount the HESA on flammable construction materials.
  - Do not mount the HESA in areas where flammable materials are stored.
  - Do not mount the HESA in areas where there is a risk of explosion.
- 
- Do not place the all-in-one system near heat sources. It is prohibited to place the all-in-one system in an environment with flammable, explosive gas, or smoke.
  - The all-in-one system should be installed in an area away from liquids. It is forbidden to install it near or below water pipes, air outlets and other locations that are prone to water condensation.
  - Ensure that the all-in-one system is installed out of the reach of children.
  - To ensure best operating status and prolonged service life, the mounting ambient temperature and humidity of the HESA should be  $\leq 45^{\circ}\text{C}$  and  $\leq 95\%$ .
  - Do not use the all-in-one system above 3000m.

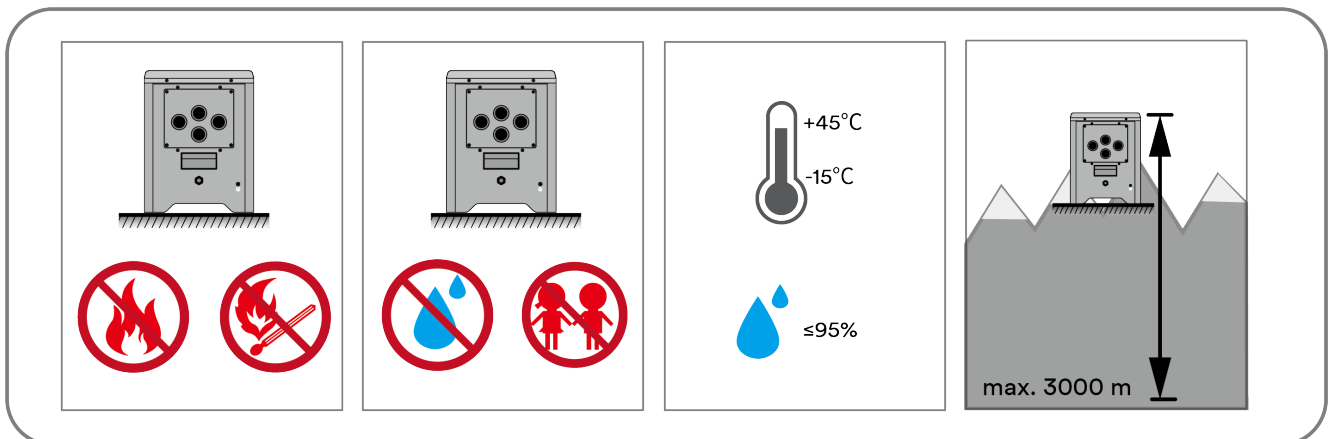

- The mounting condition must be suitable for the weight and size of the all-in-one system. The all-in-one system is suitable to be mounted on the flat floor indoors.
- To ensure adequate heat dissipation, the clearances between the all-in-one system and other objects are recommended as follows:



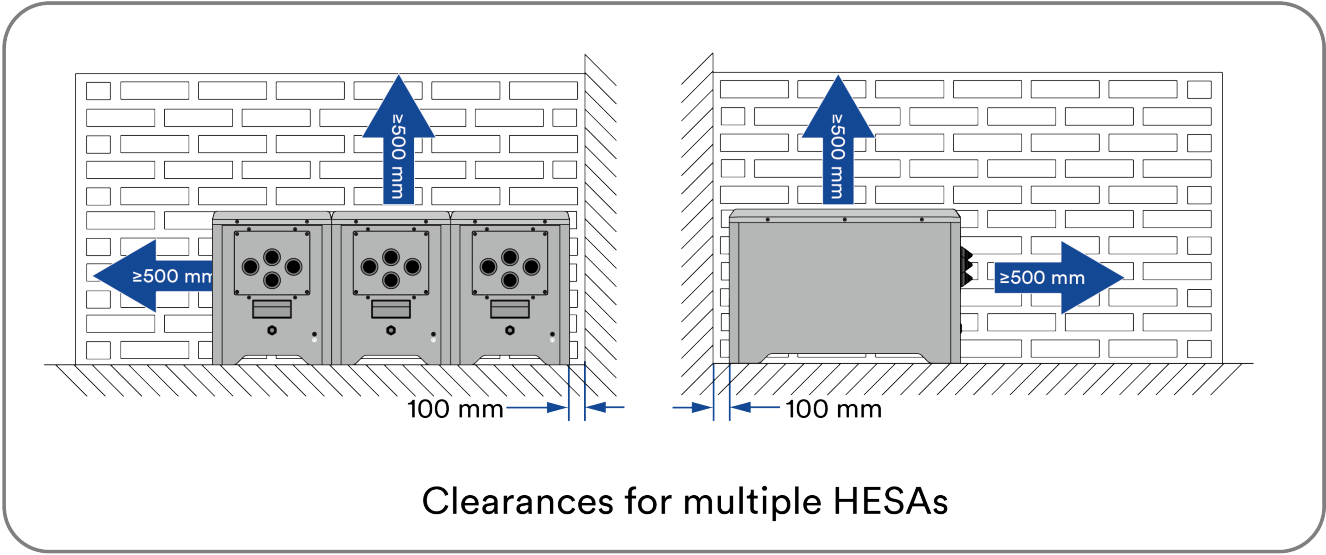
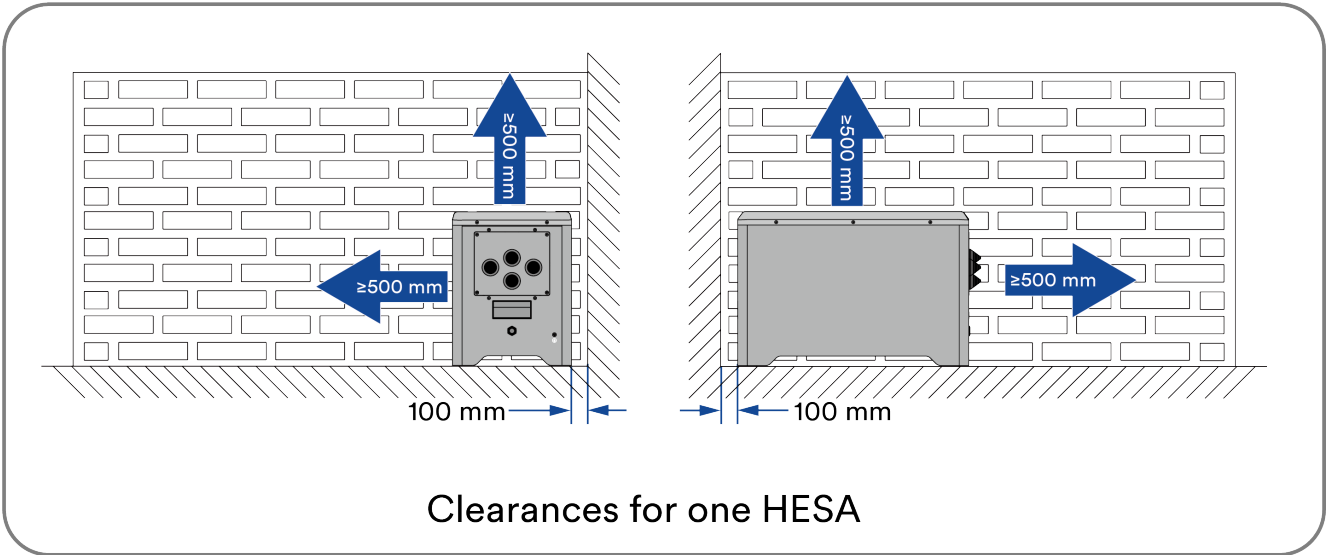

## 6 Electrical connection

### 6.1 Connection port description

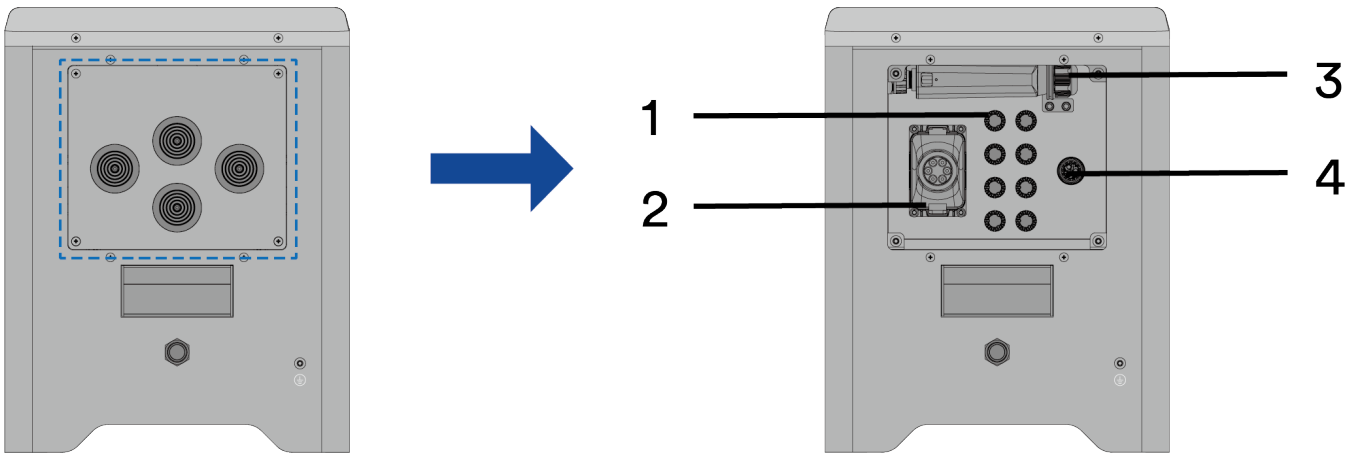

Figure shown here is for reference only. The actual product received may differ!

Object	Description
1	PV Input
2	Communication wiring area
3	Ai-Dongle
4	AC connector

### 6.2 Connecting additional grounding

The HESA is equipped with a grounding conductor monitoring device. The ground conductor monitoring device detects whether the machine is grounded in real time. If the HESA is detected to be ungrounded, the HESA will report a ground fault and disconnect from the grid.

If the grounding conductor monitoring function is deactivate or the additional grounding is required by locally standard, you can connect additional grounding to the HESA.

#### Requirements for the secondary protection ground cable:

Item	Description	Note
1	Screw	Specifications M4, complimentary
2	OT/DT terminal	Specifications M4, complimentary
3	Yellow and green ground cable	Same as the PE wire in the AC cable.

**Procedure:**

**Step 1:** Strip the grounding cable insulation. Insert the stripped part of the grounding cable into the ring terminal lug and crimp using a crimping tool.

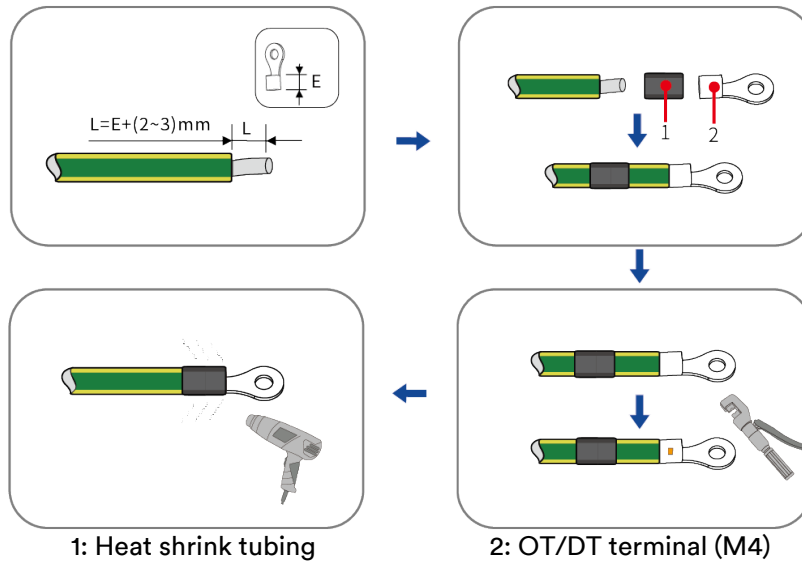

**Step 2:** Remove the screw on the ground terminal, insert the screw through the OT/DT terminal, and lock the terminal using a wrench.

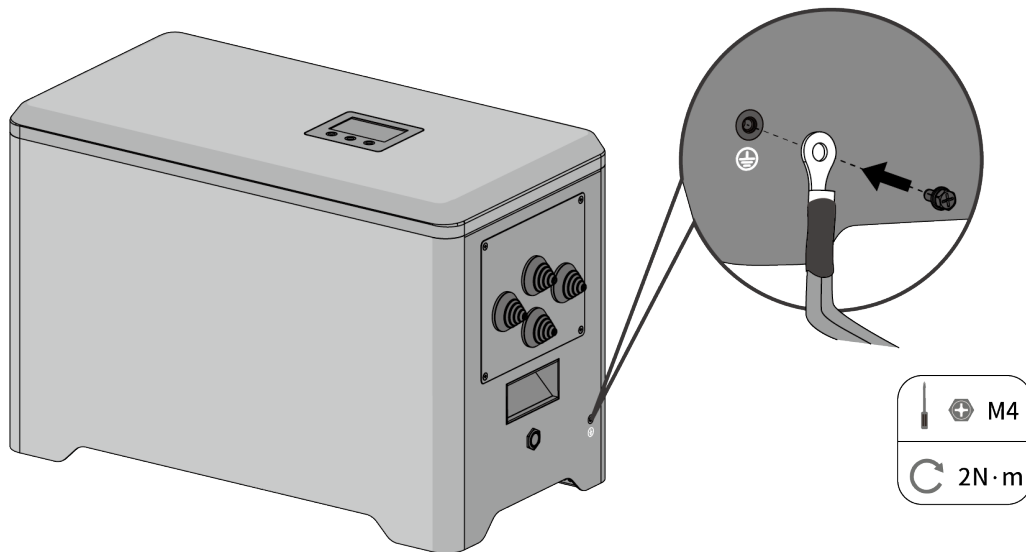

**Step 3:** Apply paint to the grounding terminal to ensure corrosion resistance.

**Complete the installation.**

## 6.3 AC connection

### 6.3.1 Requirements for the AC connection

#### Cable Requirements

The cable must be dimensioned in accordance with the local and national directives for the dimensioning of cables. The requirements for the minimum wire size derive from these directives.

Examples of factors influencing cable dimensioning are: nominal AC current, type of cable, routing method, cable bundling, ambient temperature and maximum desired line losses.

The grid connection is established using three conductors (L, N, and PE).

We recommend the following specifications for stranded copper wire.

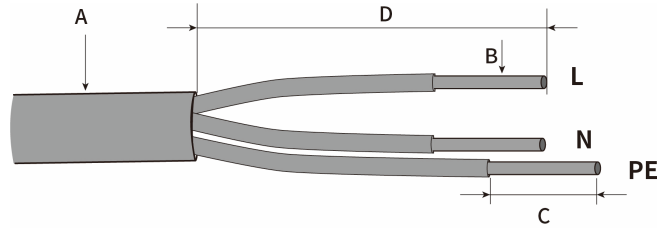

Item	Description	Value
A	External diameter	10.5-12.5mm
B	Copper cable conductor cross-section	1.5~2.5 mm <sup>2</sup>
C	Insulation stripping length	≈7 mm
D	Sheath stripping length	≈20 mm



The PE conductor must be 2 mm longer than the L and N conductors.

Larger cross-sections should be used for longer cables.

### Overvoltage category

The inverter can be used in grids of overvoltage category III or lower in accordance with IEC 60664-1. That means that the product can be permanently connected to the grid-connection point of a building.

### 6.3.2 AC cable connection

**Step 1:** Disconnect the HESA from the power grid and make sure that the HESA is not turned on.

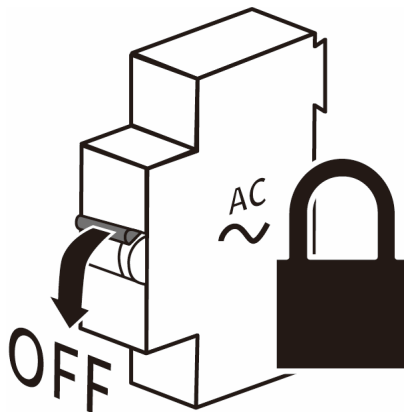

**Step 2:** Remove the cover before making electrical connection. Subtract the waterproof ring according to the wire diameter.

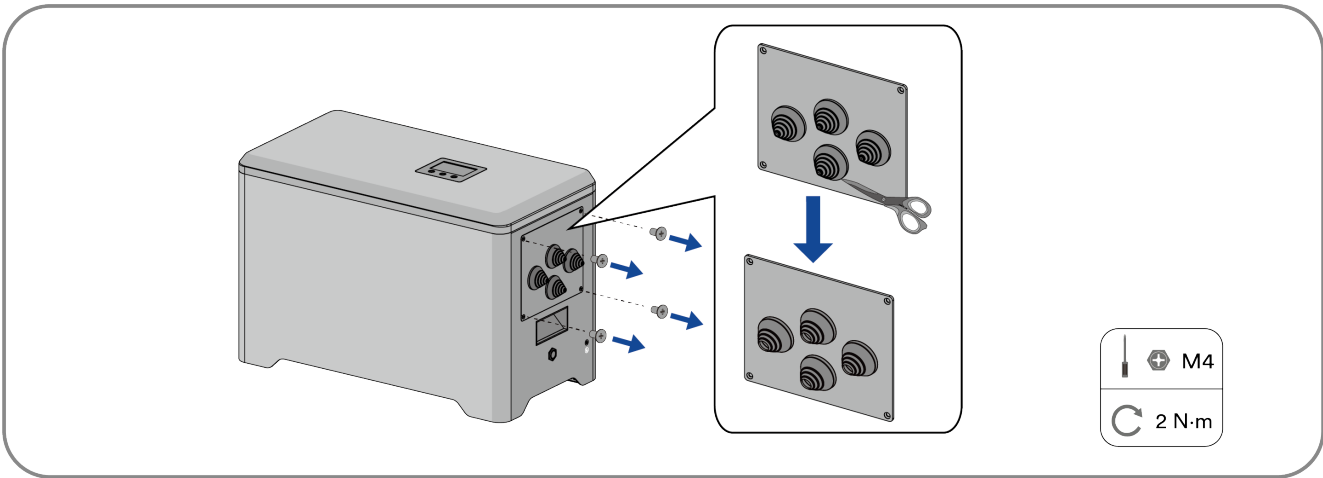
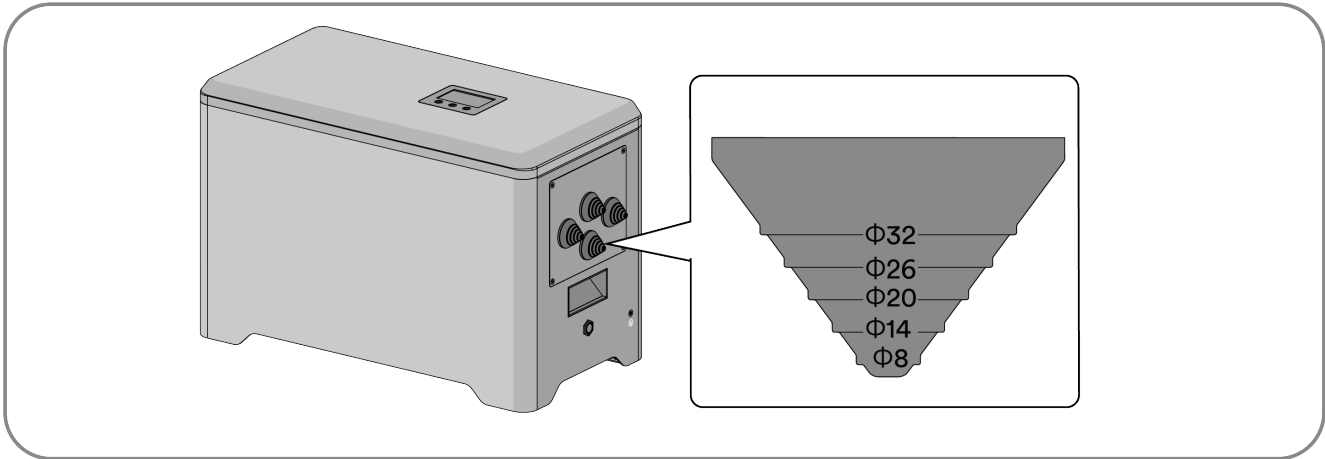

**Step 3:** Pass the AC cord through the waterproof ring.

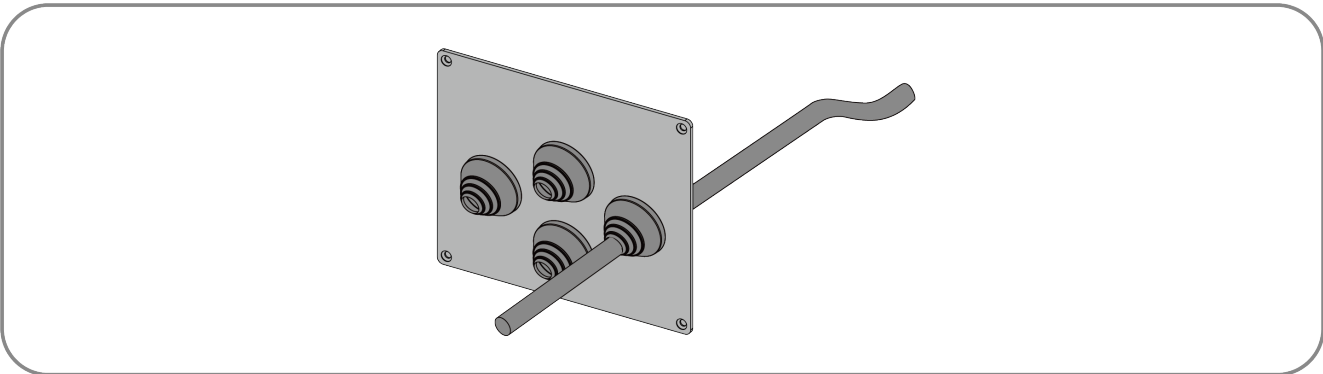

**Step 3:** Use the tool to split the connector

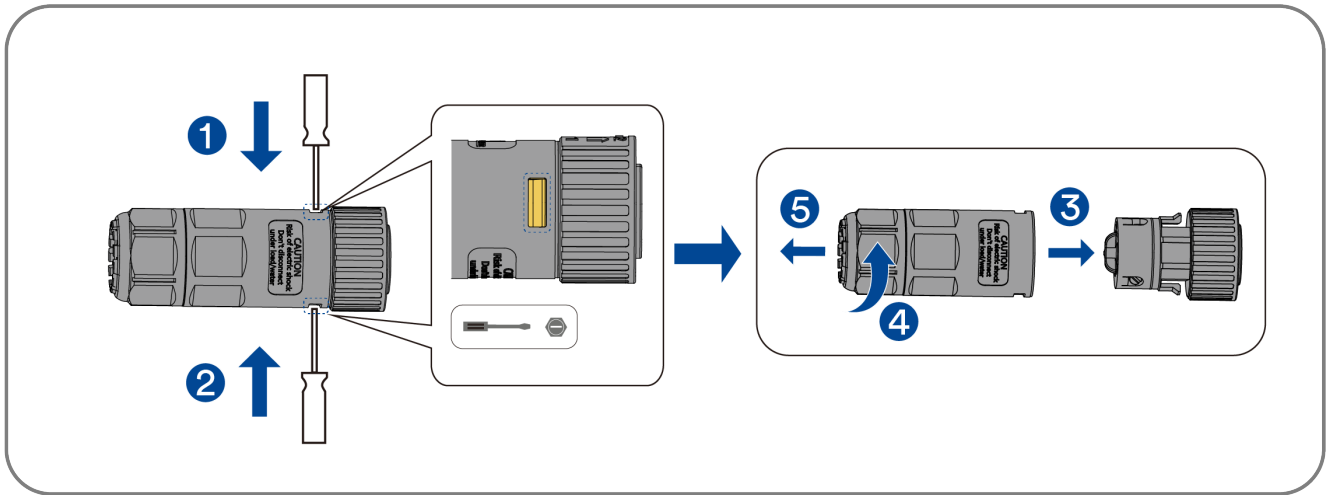

**Step 4:** Insert the conductor into a suitable ferrule acc. to DIN 46228-4 and crimp the terminals with crimping pliers.

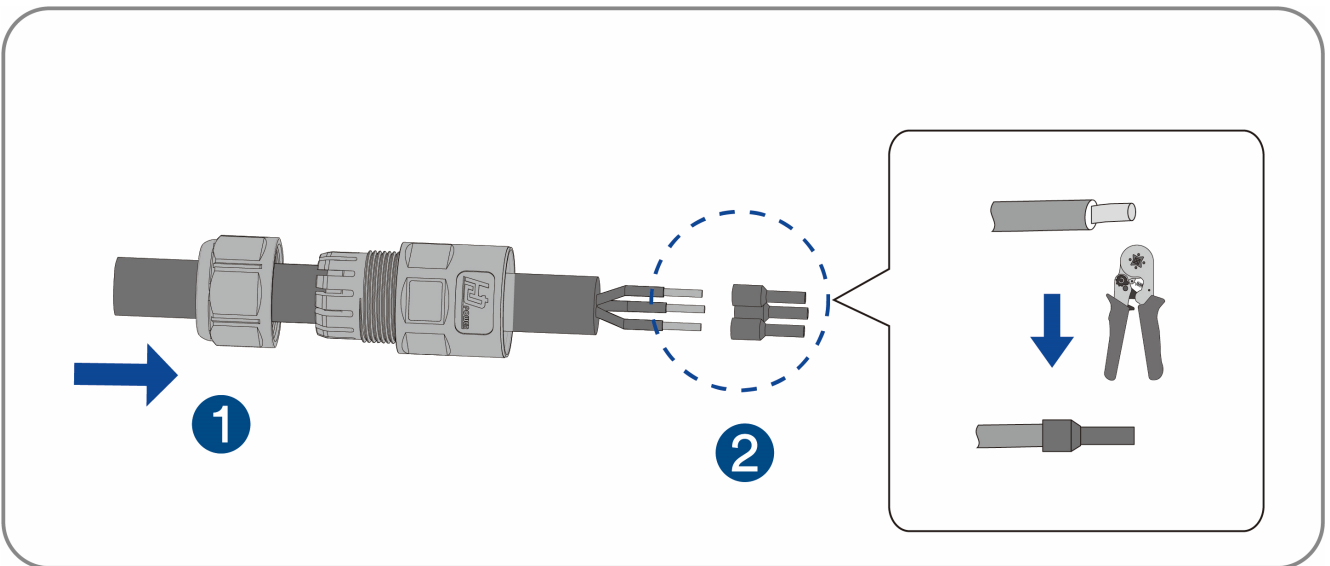

**If the L line was connected to PE terminal, the HESA will not function properly.**

- Please ensure that the type of the conductors matches the signs of the terminals on the socket element.

**Step 5:** Set the parts on the cable, insert the terminal holes in sequence. Crimp the wire with a straight screwdriver and screw the torque  $1.0 \pm 0.1 \text{ N}\cdot\text{m}$ .

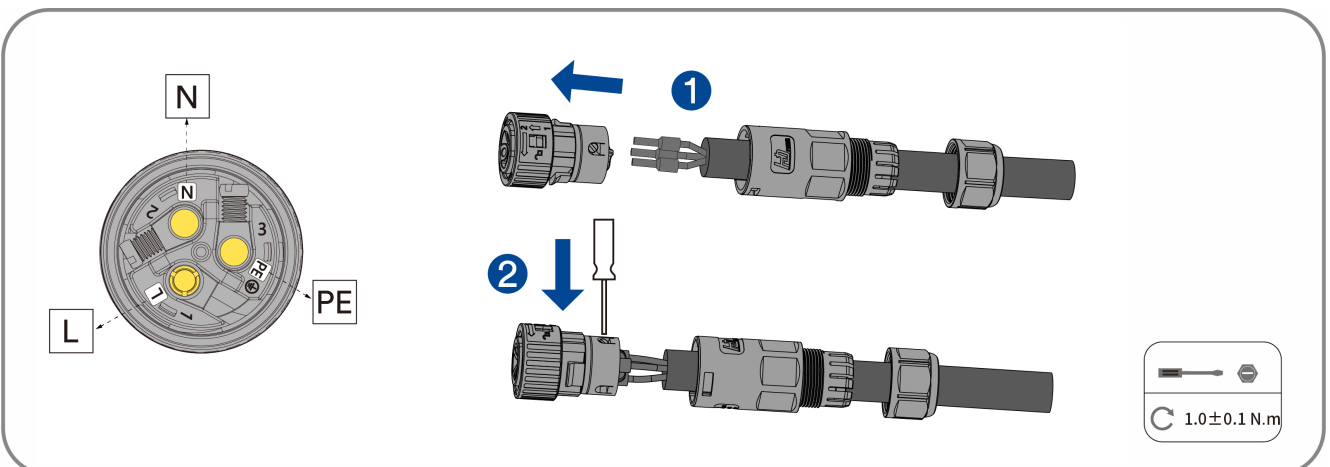

**Step 6:** Tighten the body with an open-ended wrench (torque  $2.0 \pm 0.5$  N·m).

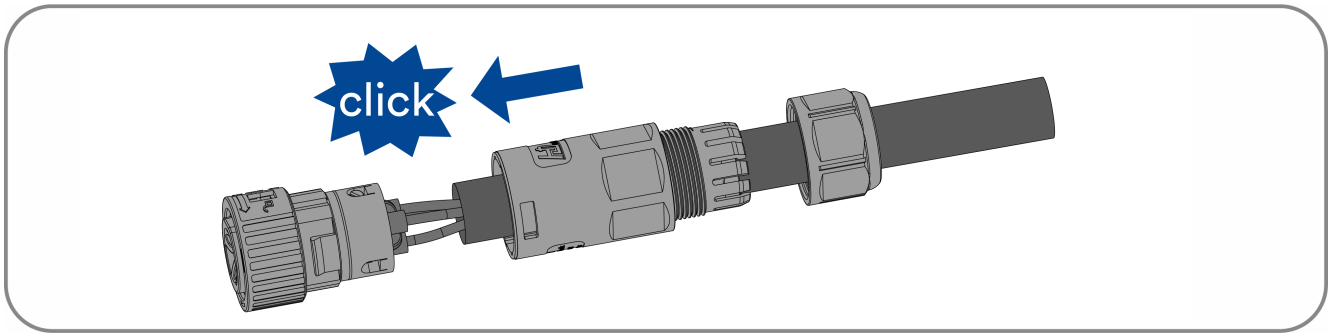

**Step 7:** Tighten the nut with an open-ended wrench (torque  $2.5 \pm 0.5$  N·m).

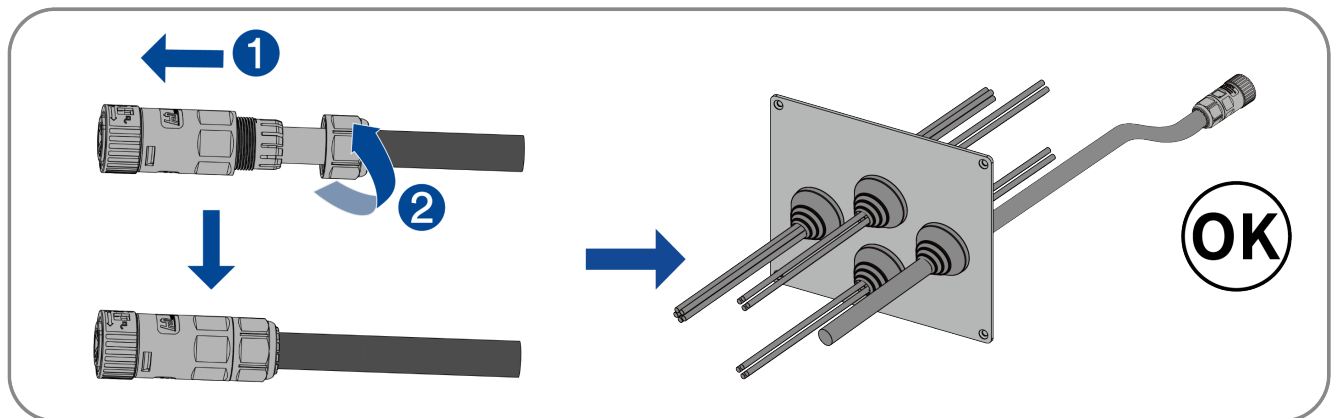

### 6.3.3 Connecting the AC connectors

**Step 1:** Insert the AC connector into the AC connection jack and tighten when you hear the "click" sound.

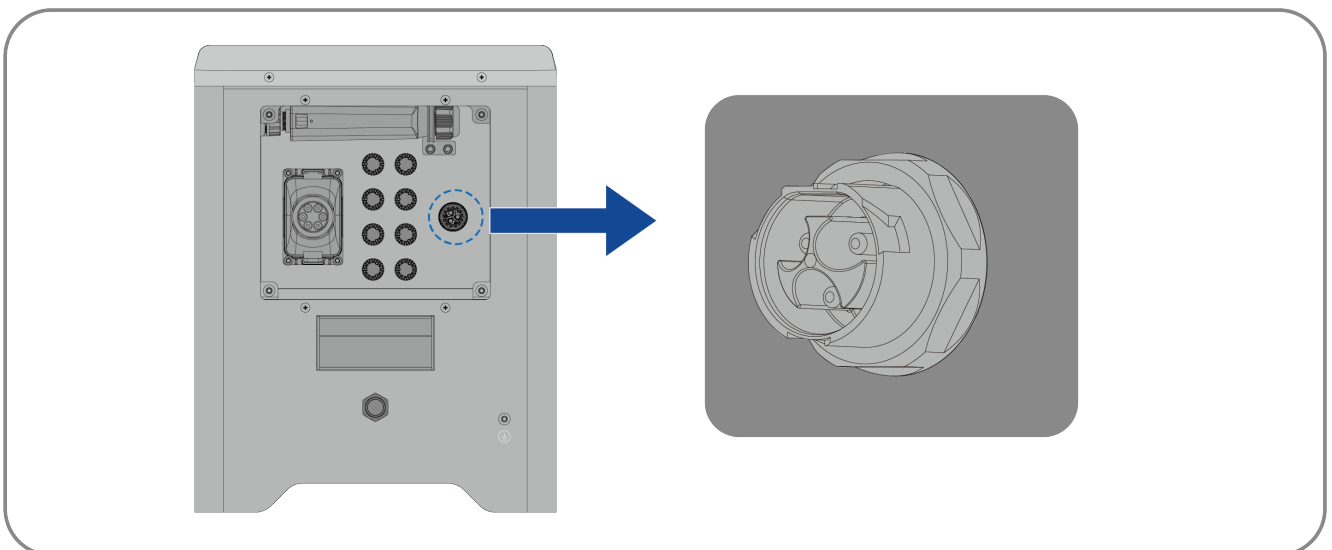

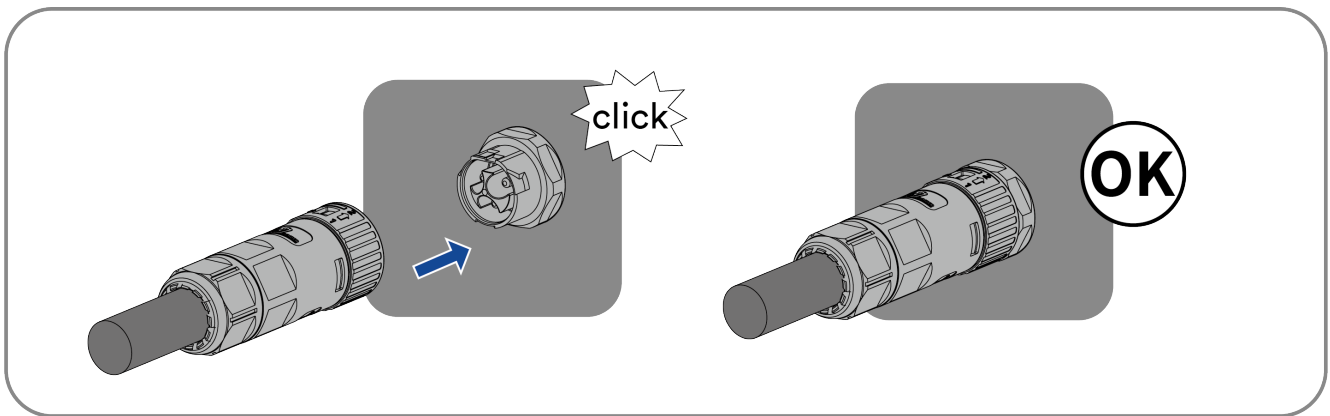

**Complete the installation.**

## 6.4 DC connection

### 6.4.1 Requirements for the DC connection

#### Requirements for the PV modules per input:

- All PV modules should be of the same type.
- All PV modules should be aligned and tilted identically.
- On the coldest day based on statistical records, the open-circuit voltage of the PV modules must never exceed the maximum input voltage of the inverter.
- The maximum input current per PV module must be maintained and must not exceed the through fault current of the DC connectors.
- The connection cables to the inverter must be equipped with the connectors included in the scope of delivery.
- The thresholds for the input voltage and the input current of the inverter must be adhered to.
- The positive connection cables of the PV modules must be equipped with the positive DC connectors. The negative connection cables of the PV modules must be equipped with the negative DC connectors.

### 6.4.2 Assembling the DC connectors



For connection to the inverter, all PV module connection cable must be fitted with the DC connectors provided. Assemble the DC connectors as described in the following.

#### Type 1 DC connector:

Assemble the DC connectors as described below. Be sure to observe the correct polarity. The DC connectors are marked with the symbols “+” and “-”.



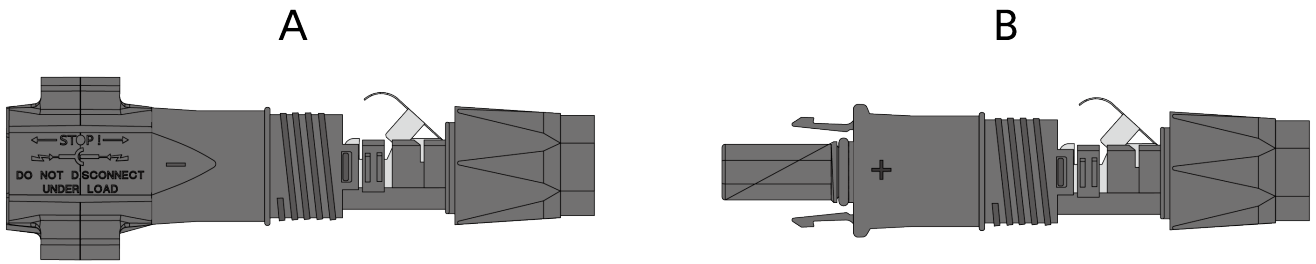

**Cable requirements:**

Item	Description	Value
1	Cable type	PV cable
2	External diameter	5-8 mm
3	Conductor cross-section	2.5-6 mm <sup>2</sup>
4	Number of copper wires	At least 7
5	The rated voltage	≥100V

**Procedure:**

**Step 1:** Refer to the step 1 of 6.3.1 AC cable connection.

**Step 2:** Pass the DC cord through the waterproof ring.

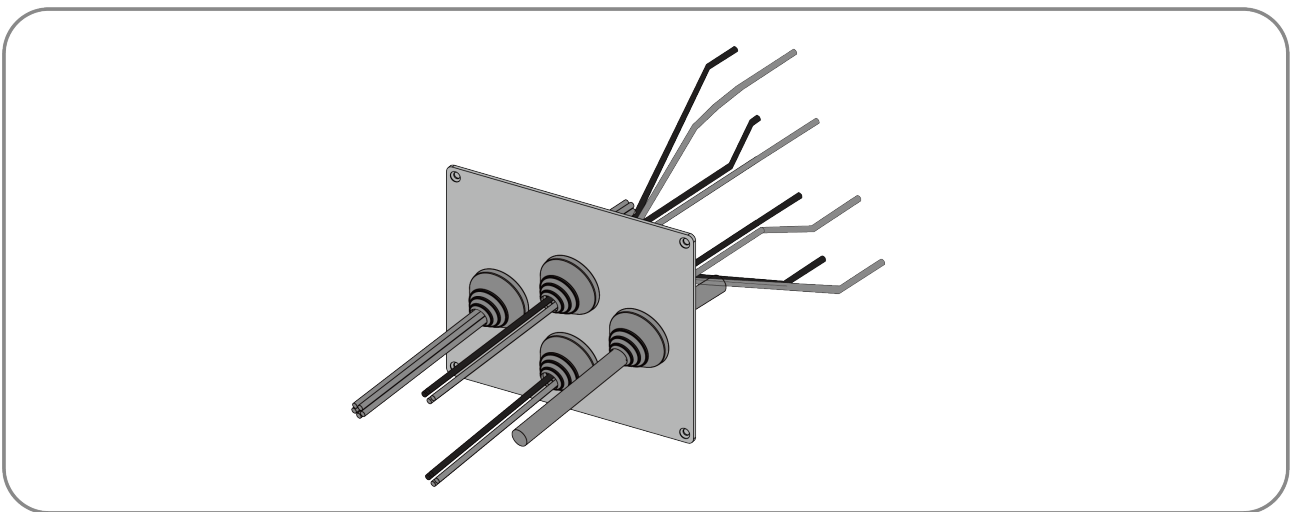

**Step 3:** Strip 12 mm off the cable insulation.

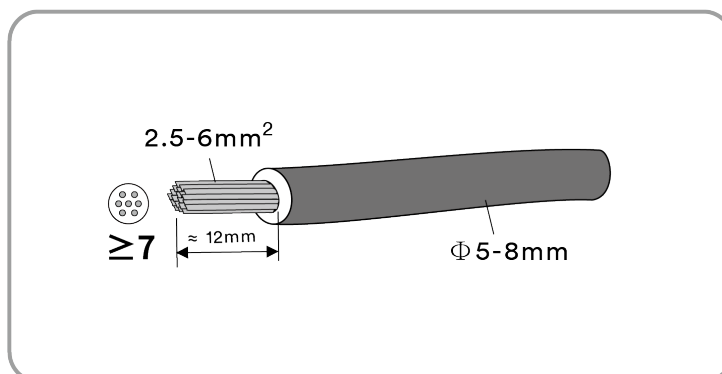

**Step 4:** Crimp the contacts with the corresponding cables. Crimping tool: PV-CZM-61100.

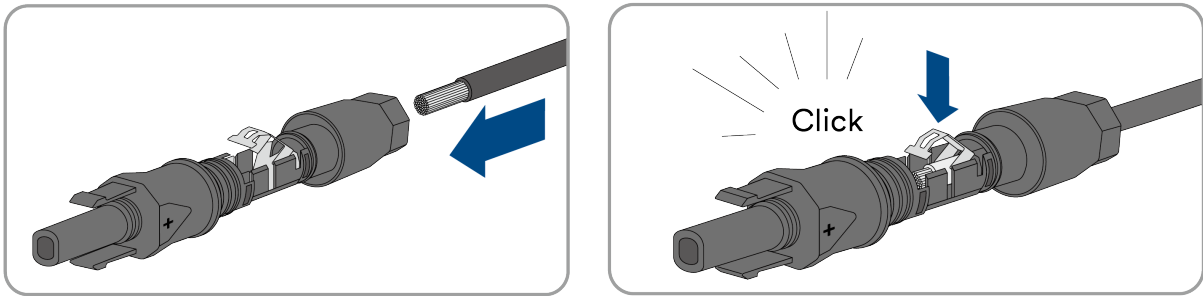

If the stranded wire is not visible in the chamber, the cable is not correctly inserted and the connector must be reassembled. To do this, the cable must be removed from the connector.

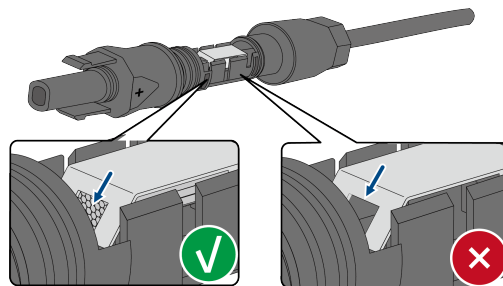

Release the clamping bracket. To do so, insert a screwdriver (blade width: 3.5mm) into the clamping bracket and pry the clamping bracket open.

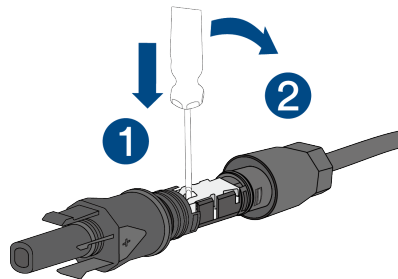

Remove the cable and go back to step 2.

**Step 5:** Push the swivel nut up to the thread and tighten the swivel nut. (SW15, Torque: 2.0Nm)

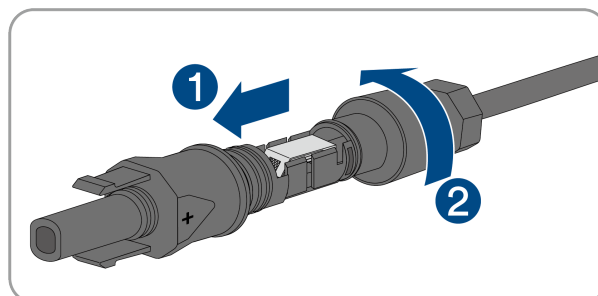

#### Type 2 DC connector:

Assemble the DC connectors as described below. Be sure to observe the correct polarity. The DC connectors are marked with the symbols “+” and “-”.

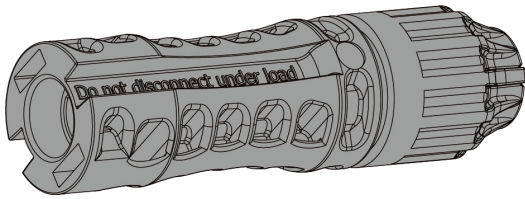
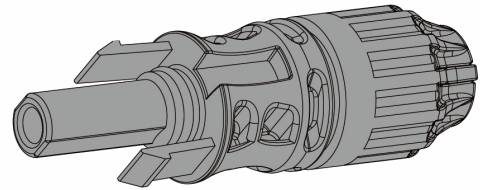
**A****B****Cable requirements:**

Item	Description	Value
1	Cable type	PV cable
2	External diameter	5-8 mm
3	Conductor cross-section	4-6 mm <sup>2</sup>
4	Number of copper wires	At least 7

**Procedure:**

**Step 1:** Refer to the step 1 of 6.3.1 AC cable connection.

**Step 2:** Pass the DC cord through the waterproof ring.

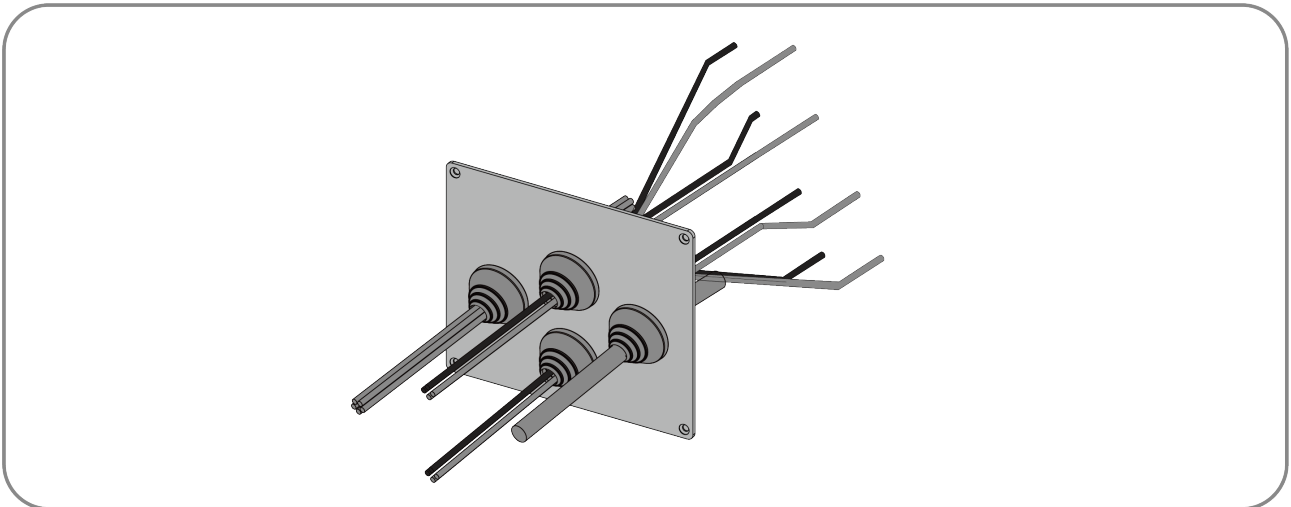

**Step 3:** Strip 8-10 mm off the cable insulation.

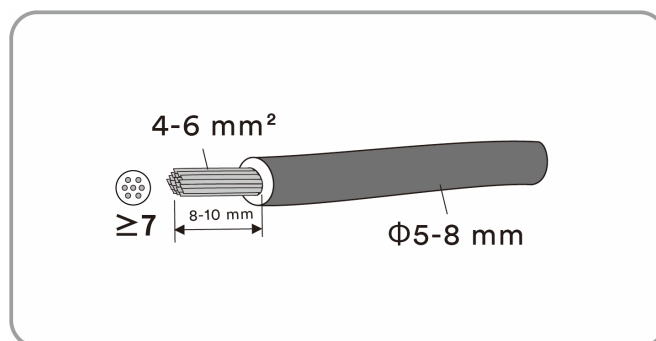

**Step 4:** Crimp the contacts with the corresponding cables. Crimping tool: PV-CZM-61100.

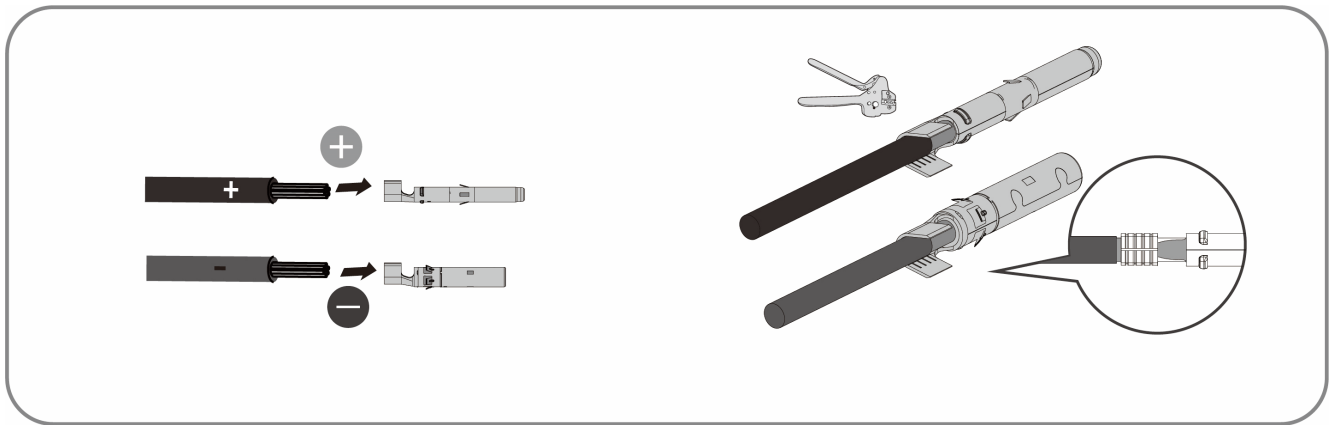

**Step 5:** Insert the contact cable assembly into back of the corresponding DC plug connector. A “click” should be heard or felt when the contact cable assembly is seated correctly and tighten the swivel nut. (Torque:2.5 Nm)

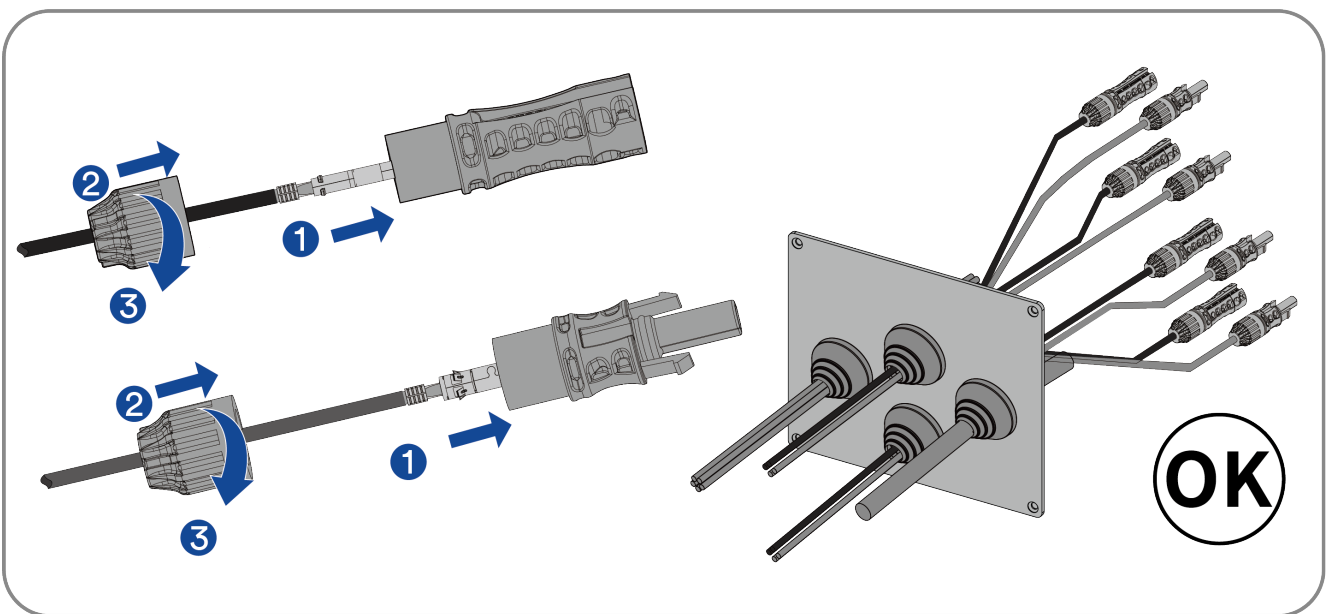

### 6.4.3 Connecting the PV module

#### **NOTICE**

**The HESA can be destroyed by overvoltage.**

If the voltage of the PV module exceeds the maximum DC input voltage of the HESA, it can be destroyed due to overvoltage. All warranty claims become void.

- Do not connect PV modules with an open-circuit voltage greater than the maximum DC input voltage of the HESA.

#### **Procedure:**

**Step 1:** Ensure that there is no power on the AC side of the HESA.

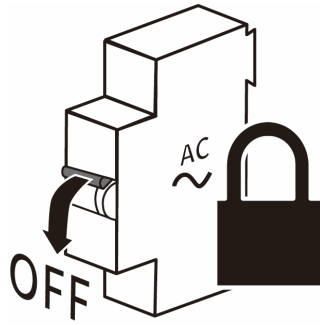

**Step 2:** Check whether the DC connector has the correct polarity. If the DC connector fits with a DC cable having the wrong polarity, the DC connector must be reassembled again. The DC cable must always have the same polarity as the DC connector.

**Step 3:** Ensure that the open-circuit voltage of the PV strings does not exceed the maximum DC input voltage of the HESA.

**Type 1 DC connector: Phoenix Contact**

- Connect the assembled DC connectors to the inverter.

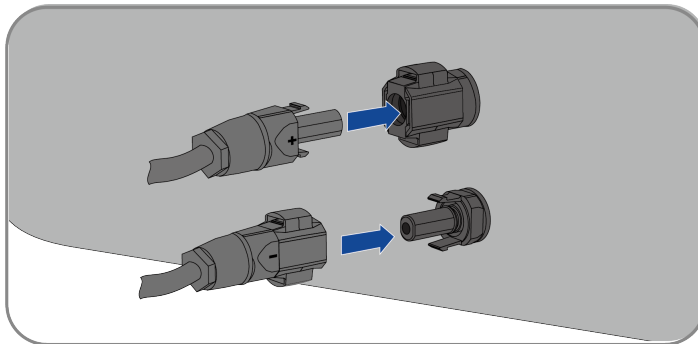

- For unused DC connectors, push down the clamping bracket and push the swivel nut up to the thread. Insert the DC connectors with sealing plugs into the corresponding DC inputs on the inverter.

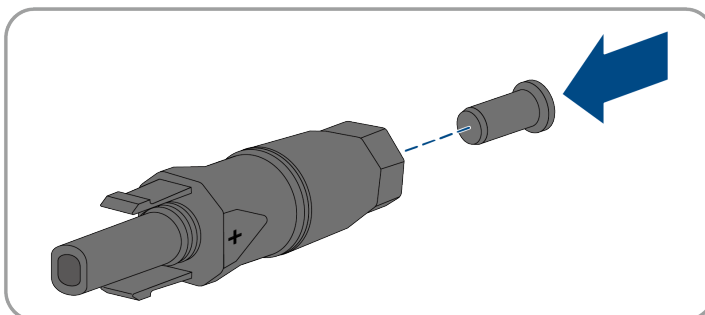
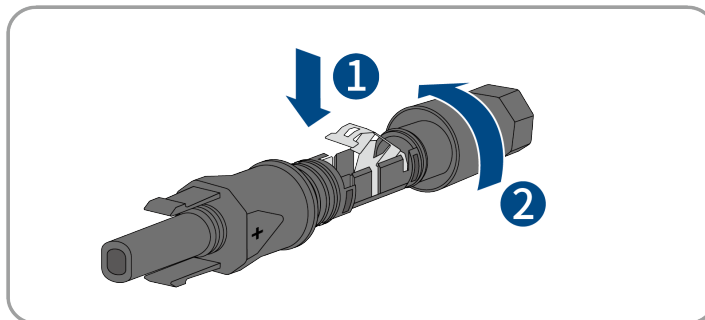

- Insert the DC connectors with sealing plugs into the corresponding DC inputs on the inverter.

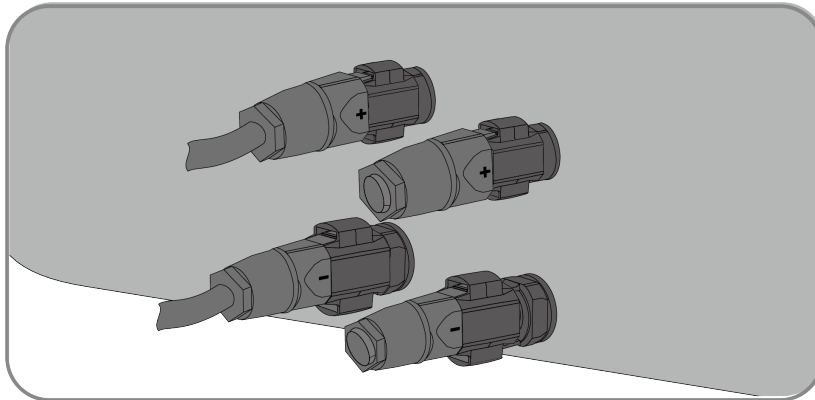

**Type 2 DC connector:**

- Step 4:** Connect the assembled DC connectors to the HESA until they audibly snap into place.

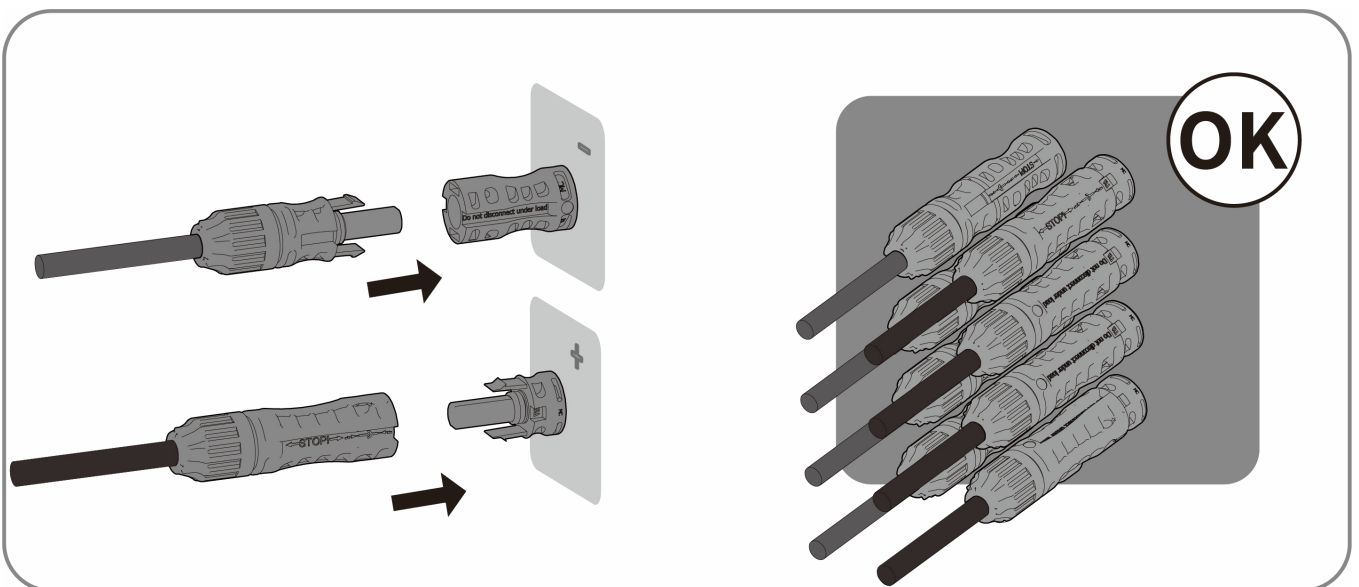
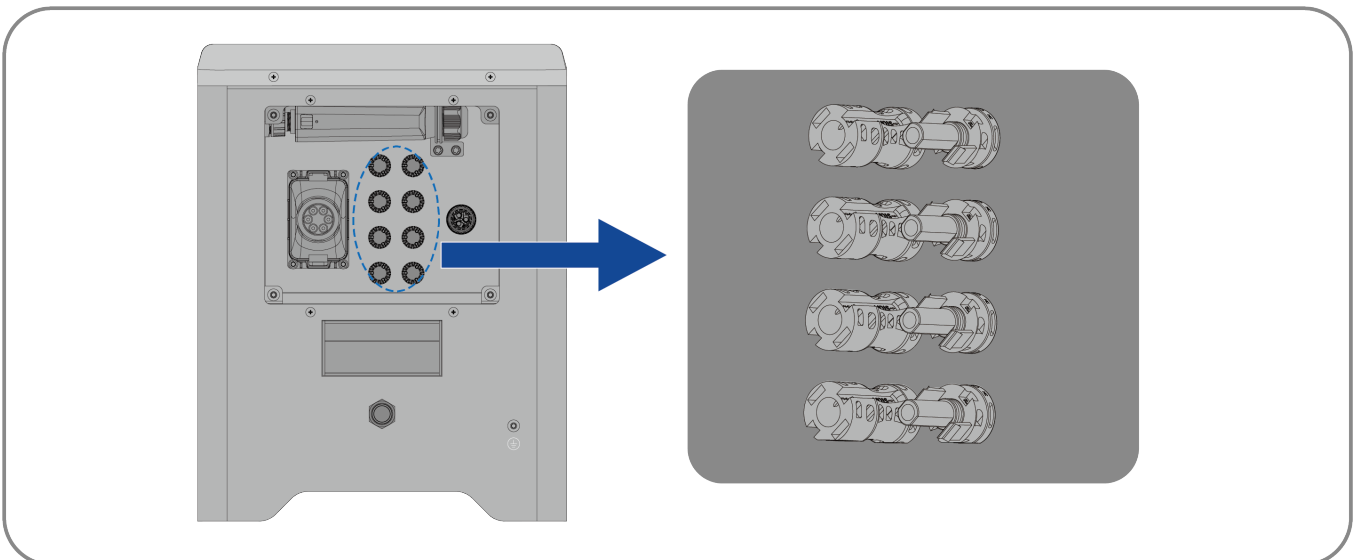

## 6.5 Communication equipment connection

### 6.5.1 Communication ports

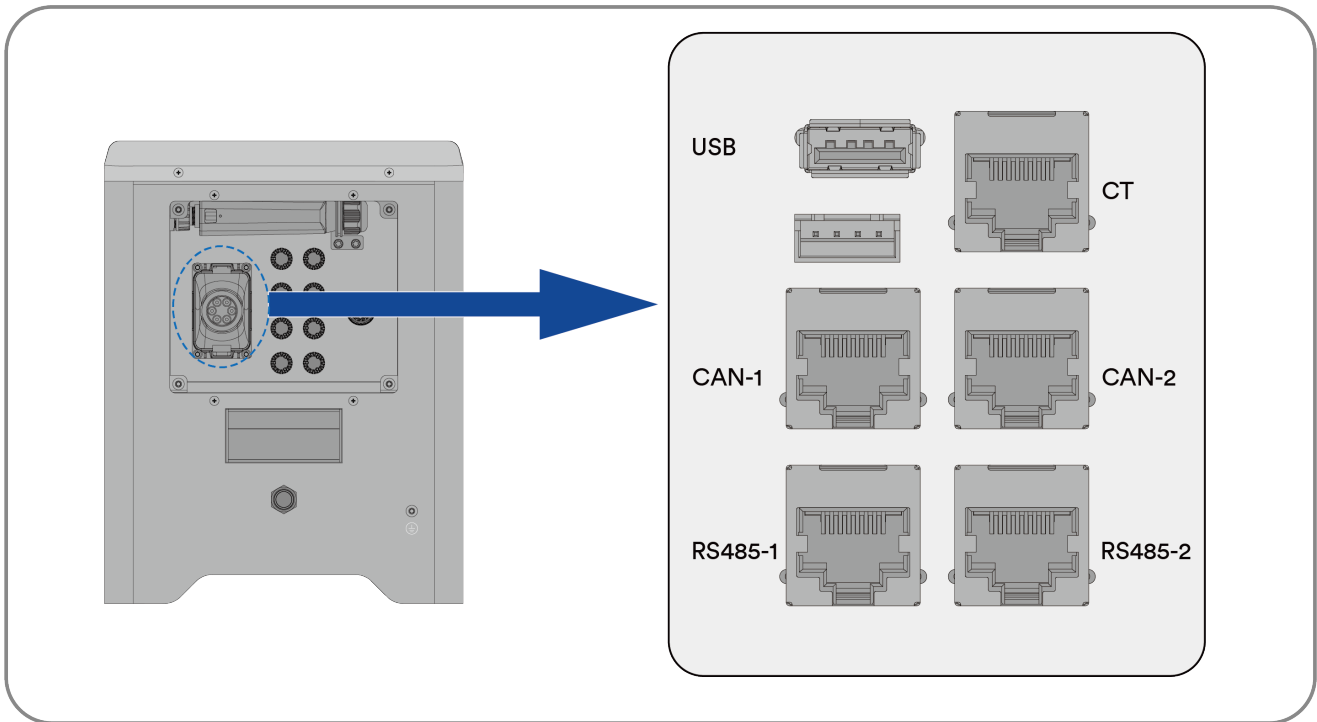

Object	Description
USB	USB port is used for formal updating.
CT	Current transformer
CAN-1/CAN-2	Communication between each inverter of the Parallel Off-grid mode or 3-phase Off-grid mode.
RS485-1/RS485-2	Reserved.

### 6.5.2 Communication cable connection



A standard straight network cable of category 5E or higher is required for connection to the RJ45 socket.

**Step 1:** Pass the network cable through the waterproof ring. Crimp the wiring terminal.

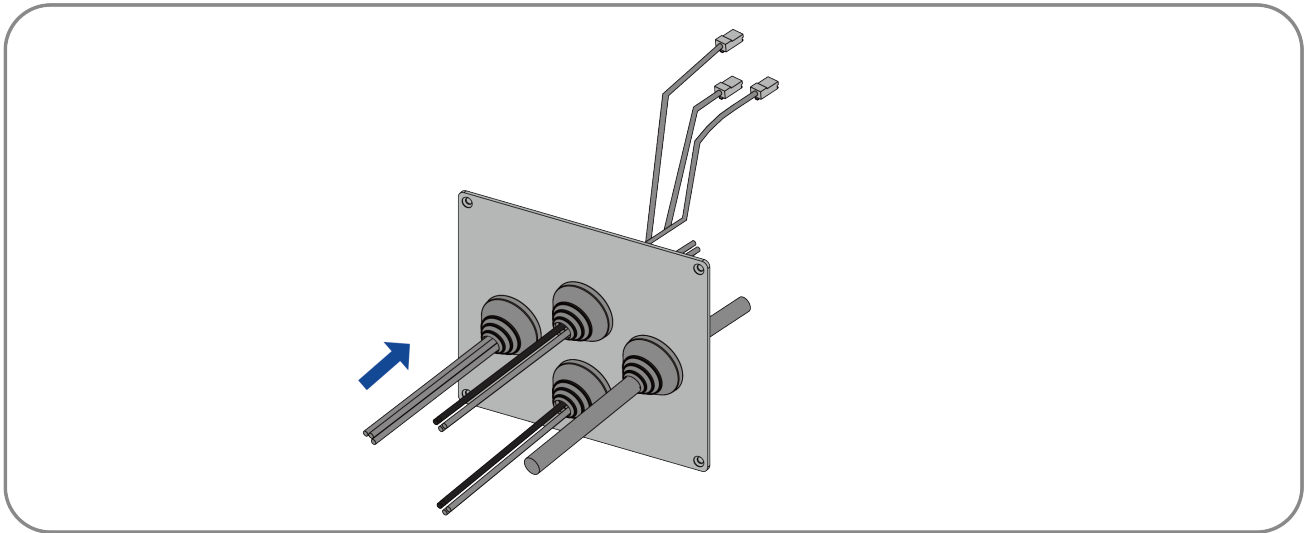

**Step 2:** Remove the communication cover.

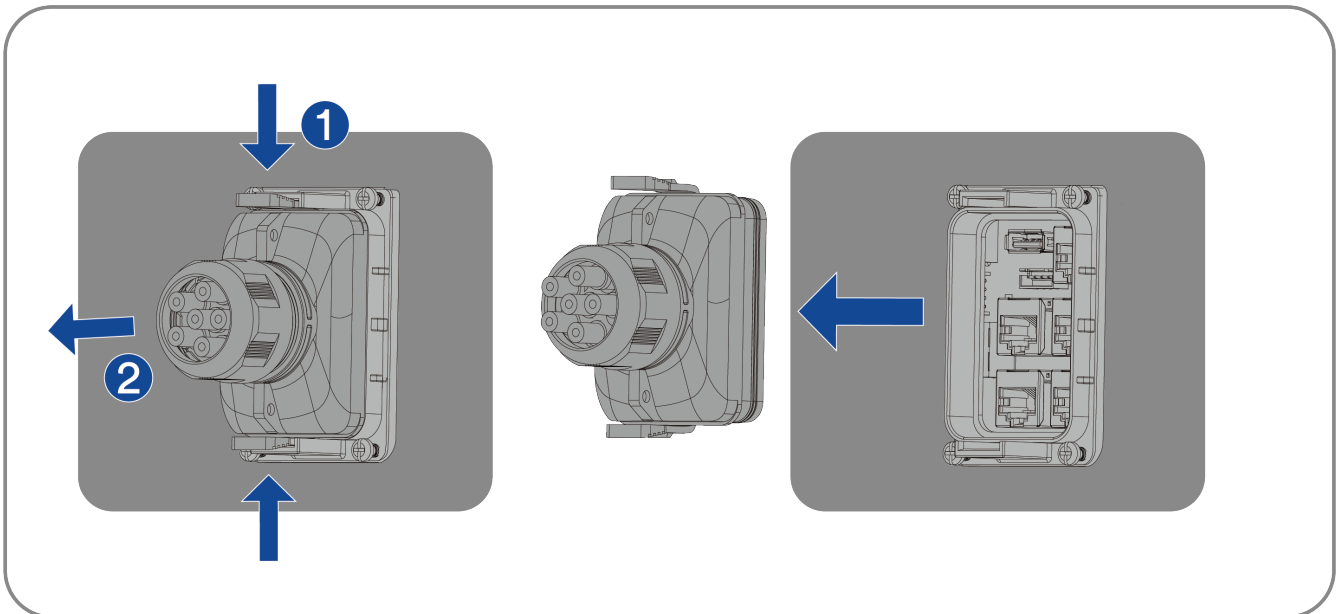

**Step 3:** Route the communication cable through the communication cover.

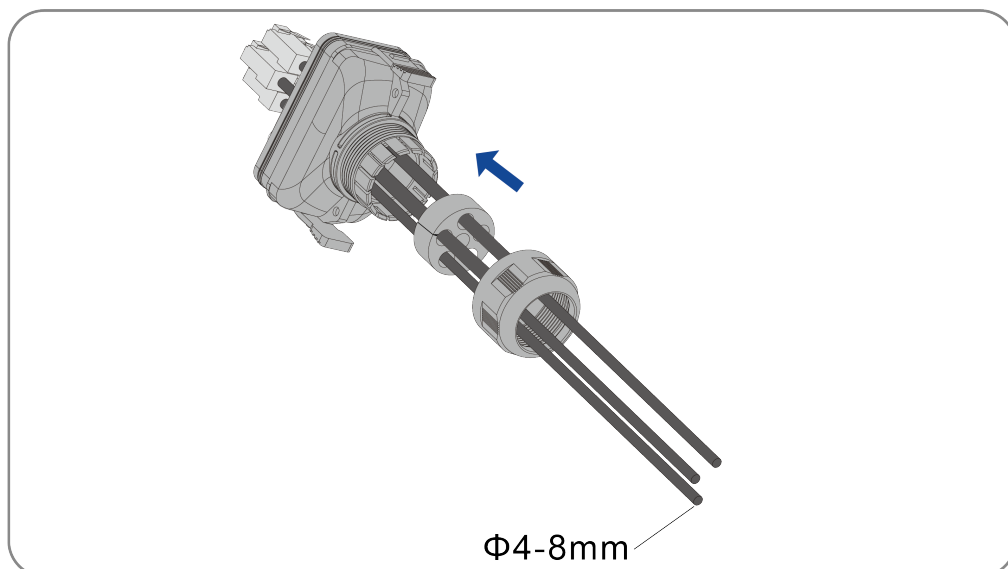



**Step 4:** Connect the communication cable crimped to the corresponding communication port

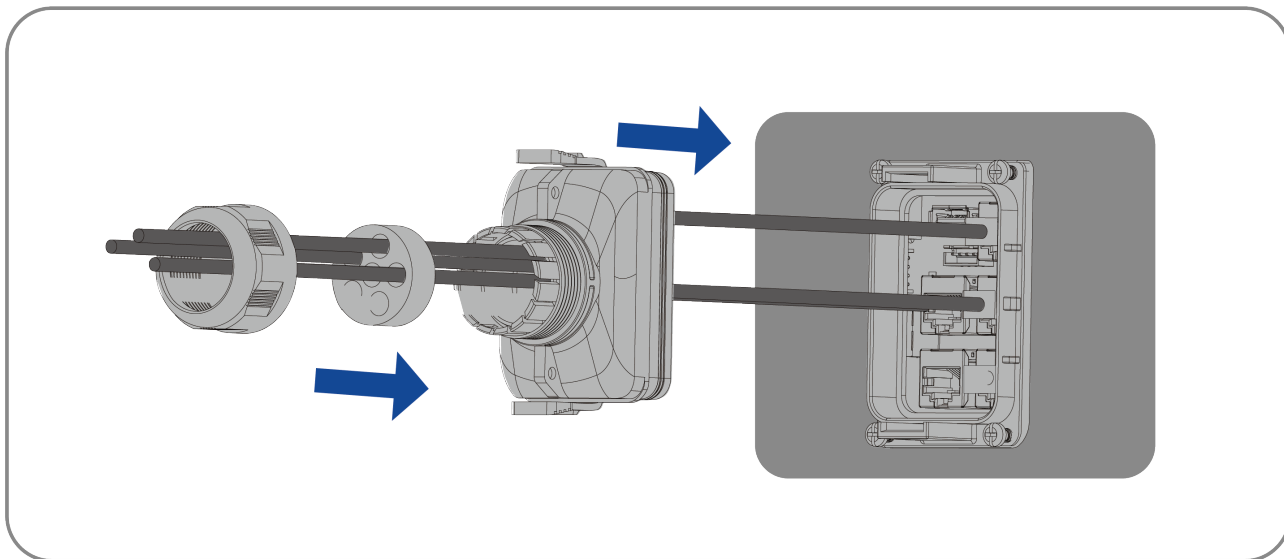

**Step 5:** Tighten the cable gland nuts.

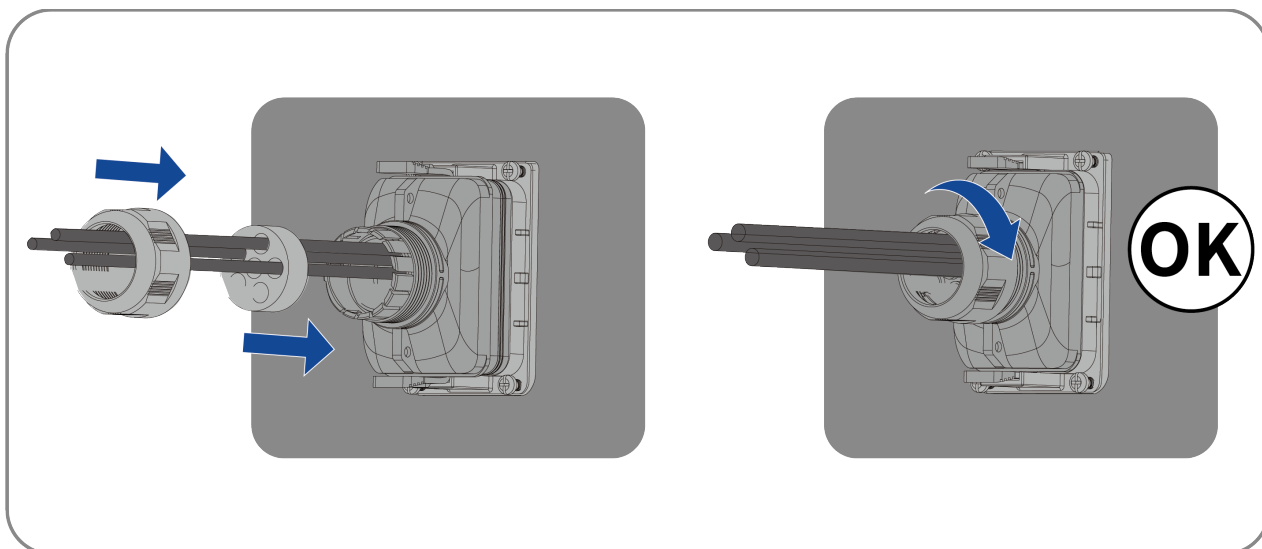

## 7 Commissioning and operating

### 7.1 Inspection before commissioning

Check the following items before starting the HESA:

- Ensure that the machine's exposed metal surface has a ground connection.
- Check that the DC voltage of the PV module does not exceed the permitted limits. The open-circuit voltage of the PV strings should not exceed 50V.
- Ensure the DC voltage has the correct polarity. Ensure that the PV cables are connected according to the wiring diagram.

#### **CAUTION**

##### **Danger to life due to the presence of AC Voltage!**

Touching the live conductors can lead to lethal electric shocks.

- Only touch the insulation of the AC cables.
  - Wear personal protective equipment such as insulating gloves.
- 
- Check that the grid voltage at the point of connection of the HESA complies with the permitted value.
  - Ensure that the AC cables are connected according to the wiring diagram, and ensure the
  - AC L and N has the correct polarity. Otherwise the machine does not work.
  - Ensure that the CT is connected according to the CT diagram, and the wiring sequence and direction are correct.
  - Ensure the machine is placed on a flat surface.
  - Ensure the front cover is installed correctly.

### 7.2 Commissioning procedure

If all of the items mentioned above meet the requirements, proceed as follows to start up the inverter for the first time.

**Step 1:** Switch on the battery circuit button.

**Step 2:** Set initial protection parameters via the Solplanet App. For details, please refer to "8.4 Create a plant".

**Step 3:** Switch on the AC circuit breaker. If the irradiation and grid conditions meet requirements, the HESA will operate normally

**Step 4:** Observe the display screen to ensure that the HESA operates normally

### 7.3 Checking the operating status

Through button operation, the screen can display different information such as operation parameters and power generation status.

**Step 1:** First short press the "DOWN" key, the voltage, current and power of PV side is shown on the screen.

**Step 2:** Second short press the "DOWN" key, the voltage, current and power of AC side is shown on the screen.

**Step 3:** Third short press the “DOWN” key, the voltage, current and power of Battery is shown on the screen.

**Step 4:** Fourth short press the “DOWN” key, the fault information is shown on the screen.

**Step 5:** Short press the “HOME” key, the screen return to the home page.

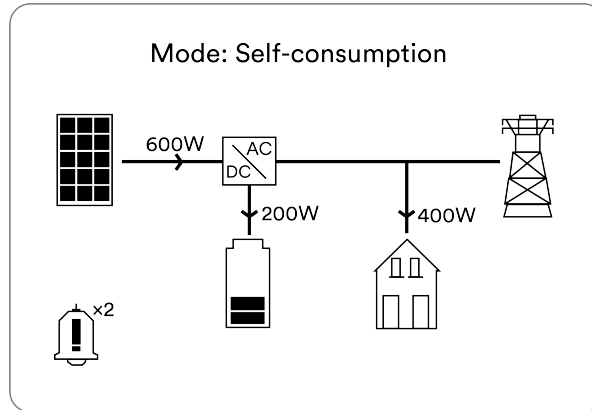

Home page

	PV1: 45.4V 0.0A 0W
	PV2: 45.4V 0.0A 0W
	PV3: 45.6V 0.0A 0W
	PV4: 45.6V 0.0A 0W

Step 1

Voltage: 220.5V

Current: 3.2A

Power: 705W

Step 2

Error Code: 34

AC Voltage Out of Range

Waiting Code: 175

Brttery Soc Low

Step 4

SOC: 56%

Voltage: 45.0V

Current: -20.0A

Power: -0.9K W

Step 3

## 7.4 Configure the parameter on the screen

The display allows accessing the configuration of the basic parameters.

1. Press the “HOME” key over 2 second, the parameter setting is shown on the screen.
2. Short Press “UN” or “DOWN” key to choose the parameter, and then short press “HOME” to enter the next level or confirm the setting.

3. Press the "HOME" key over 2 second again, the screen return to the previous level.

**Grid Code**

Grid Code: VDE4105  
Work Mode: Simple  
Rated Power: 600W  
Language: English



Grid Code

EN 50549-1	ES RD1699
VDE4105	CEI0-21 2019
	ES RD 647 LV
...	
G98-1	

**Work Mode**

Grid Code: VDE4105  
Work Mode: Simple  
Rated Power: 600W  
Language: English



Work Mode

Simple ▶  
Self-consumption  
Custom



Work Mode -> Simple

Discharge Type: Fixed  
Discharge Power: 500W  
Start Time: hh:mm  
End Time: hh:mm

**Language**

Grid Code: VDE4105  
Work Mode: Simple  
Rated Power: 600W  
Language: English



Language

English  
German

## 8 Solplanet APP

### 8.1 Brief introduction

The Solplanet App can establish communication connection to the HESA via the WLAN, there by achieving near-end maintenance on the HESA. Users can view the HESA information and set parameters through the App.

### 8.2 Download and install

Scan the following QR code to download and install the App according to the prompt information.



Android



iOS

### 8.3 Create an account

If you do not have an account, you need to register a new account first.

#### Procedure:

**Step 1:** Open Solplanet App to enter the login screen, and tap “Do not have an account” to enter the next screen.

**Step 2:** The user groups “Business user” and “End user” need be selected according to your identity, and tap “Next step”.



The end user and the business user have the different permissions for setting parameters.

The end user only can set the parameter during commissioning. The business user has more permissions, but they need submit more identity authentication documents.

**Step 3:** Enter the right mobile phone number (Via SMS) or E-mail address (Via mail). And tap the “Send verification code”

**Step 4:** Enter the correct verification code to automatically enter the next page.

**Step 5:** Set the password and click “Register” to complete the registration.

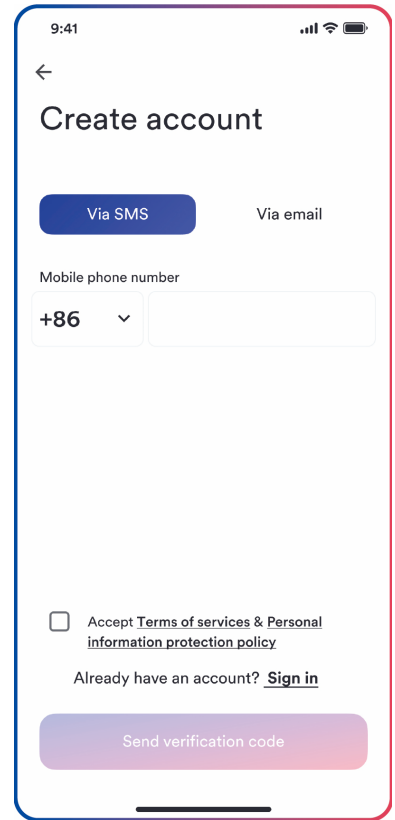
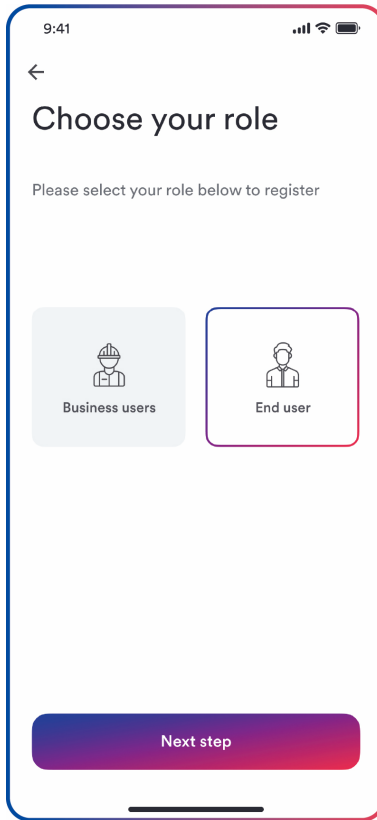
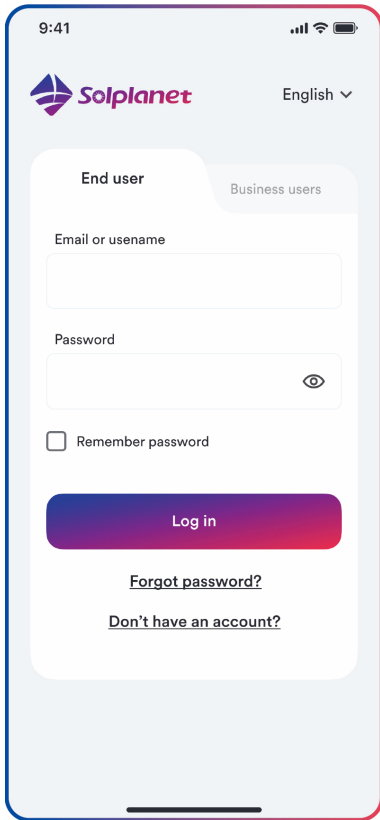

Step 1

Step 2

Step 3

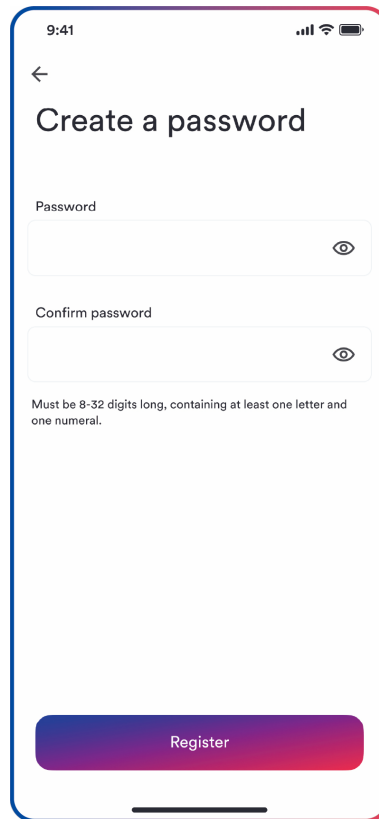
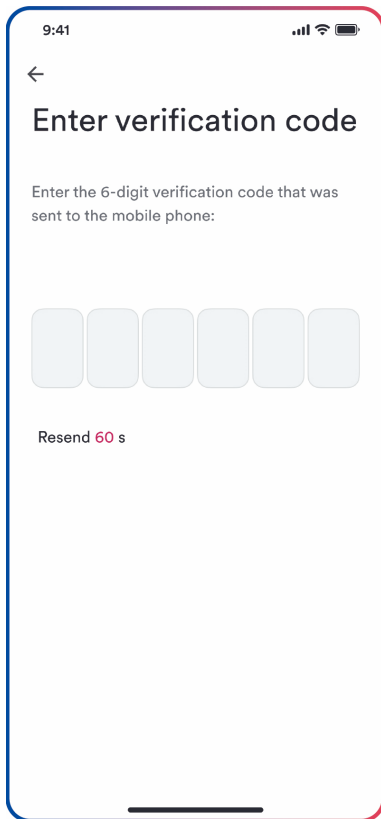

Step 4

Step 5

## 8.4 Create a plant

Procedure:

**Step 1:** Open Solplanet App to enter the login screen, enter the account name and password, and tap “Log in” to enter the next screen.

**Step 2:** Tap the symbol “+” to enter the next screen, and tap “Create or modify a plant”, then the camera of the mobile automatically turns on, and scan the QR code of the Ai- dongle to enter the next screen, tap “Create new plant” to the next screen.

**Step 3:** Enter the PV plant information in all fields marked with a red asterix, and tap “Create” to enter the next screen.

**Step 4:** After the planet created, tap “Add dongle to the plant”, and tap “Add to plant” to the next screen.

**Step 5:** Tap “Connect to dongle access point”, the smart mobile will connect to Ai- dongle hotspot automatically. The inverter list can be found after the connection successful.

**Step 6:** Tap the inverter serial number that matches your inverter, then the setting parameter can be set. The detail description can be found at section 8.5.



The grid code should be chosen at this step. And the parameters also should be set if the grid company has the different requirements.

**Step 7:** The Energy Management shall be set here. Tap “Energy storage settings” to the next page, then tap “Battery settings” to choose the energy management mode.

**Step 8:** After setting the working mode, tap the left arrow to go back the inverter list page. Then tap “Next step” to enter the next page.

**Step 9:** Set the parameter of the “Export Power Control” , and tap “Save” after the parameter configuration. Then tap “Nest step” to enter the next page. (Users need to select **CT-STMHALL** as the Meter type)

**Step 10:** Tap “Continue”, and choose WiFi network from the list, and enter WiFi network password. Then tap “continue” to enter the next step.

**Step 11:** Observe whether the Led blue light of the dongle stays on. If it is always on, it means that the network configuration is successful, and you can tap “Complete” to complete the configuration. Otherwise, you need to go back to the previous step and re-enter the Wi-Fi password.

**Step 12:** Now the new plant have been created. Tap the plant to review the information of the plant.

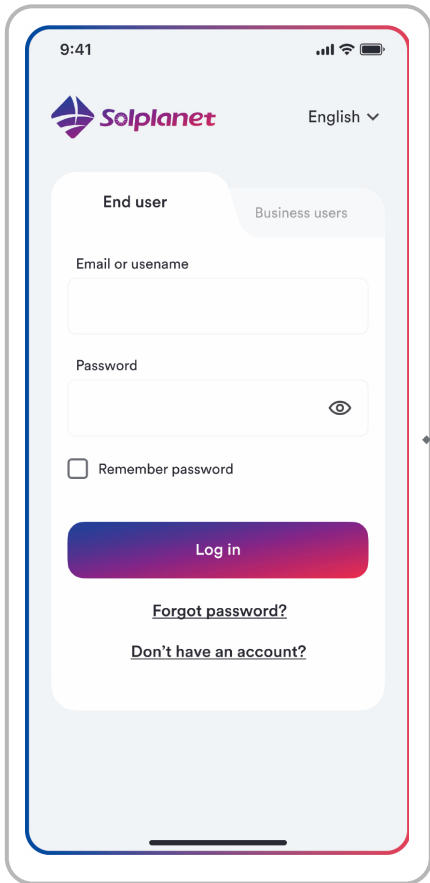

Step 1

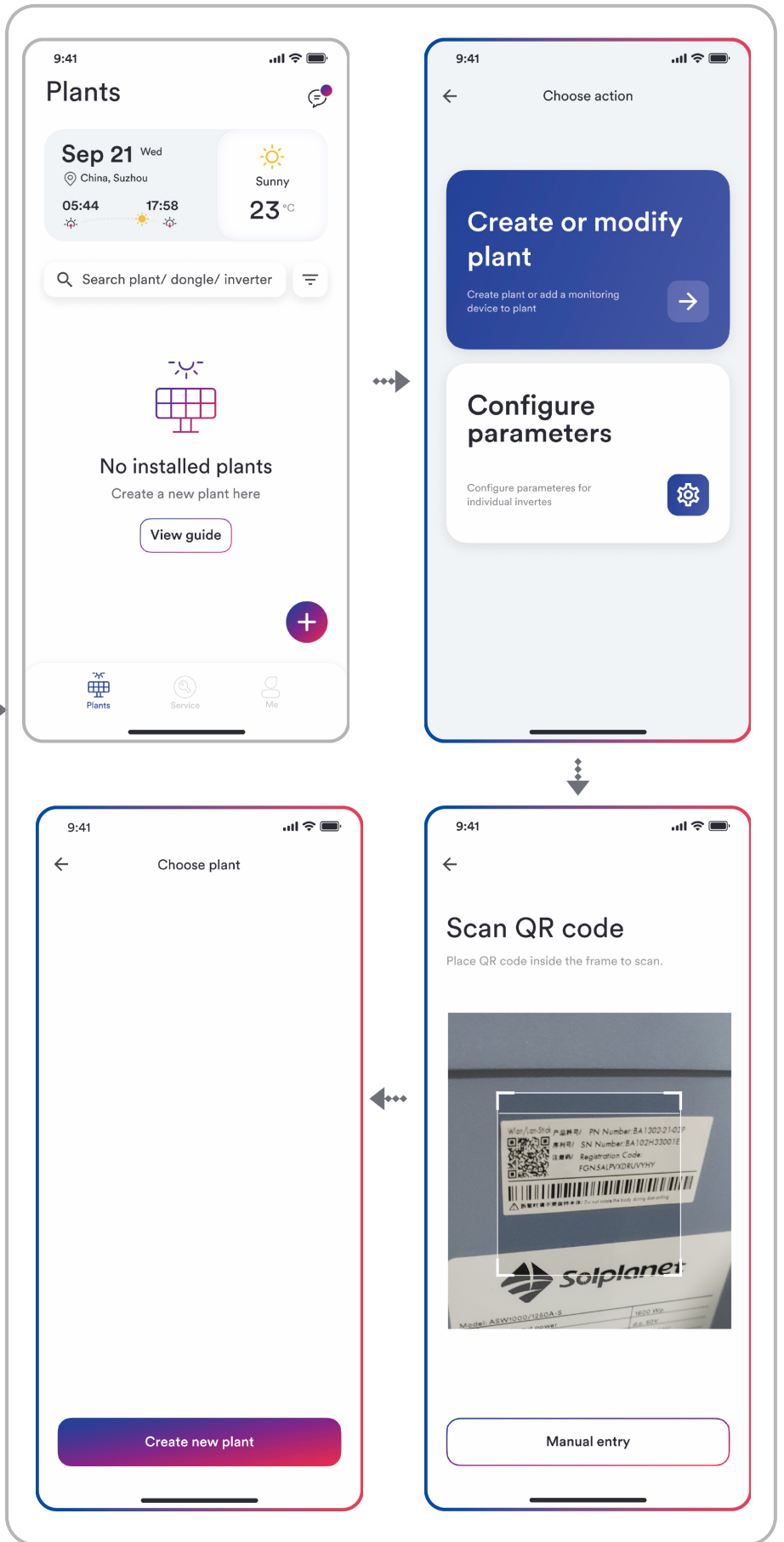

Step 2



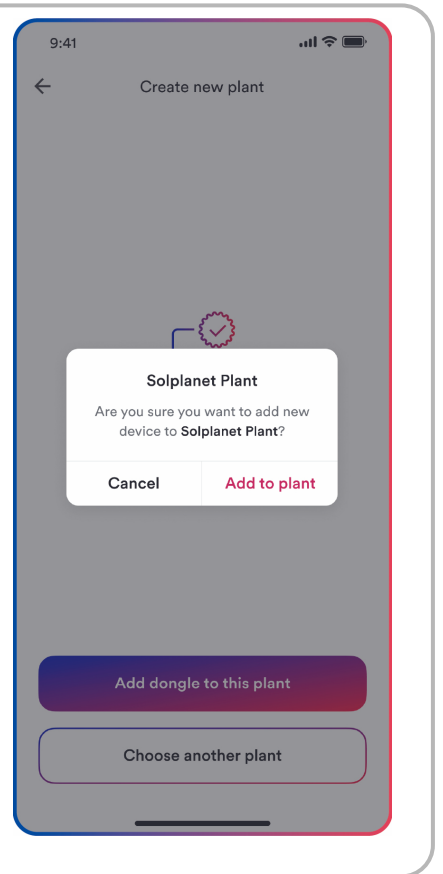
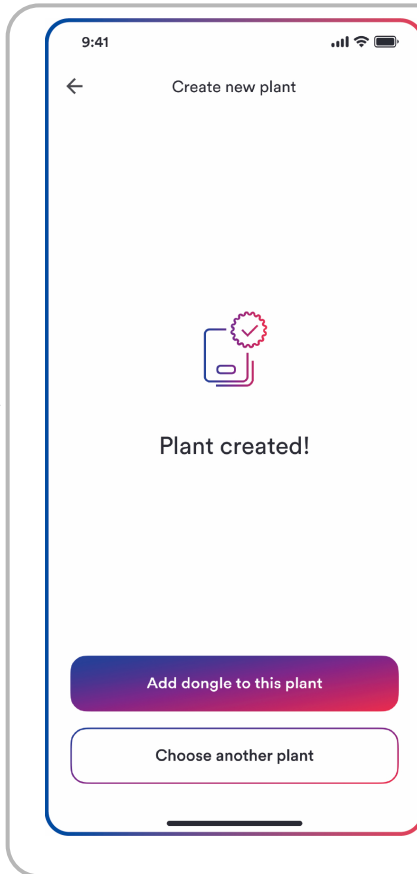
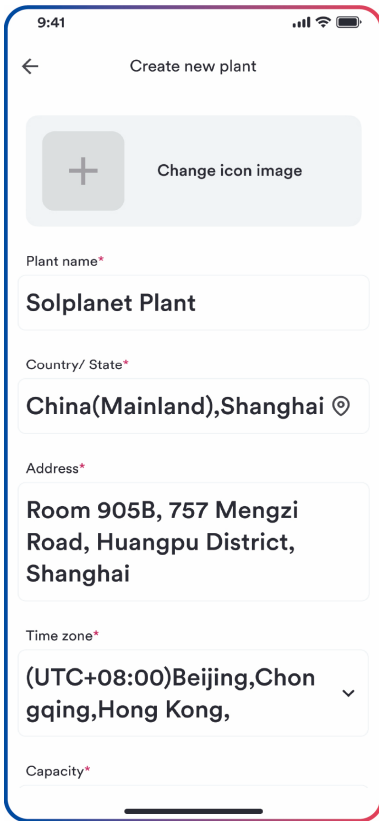

Step 3

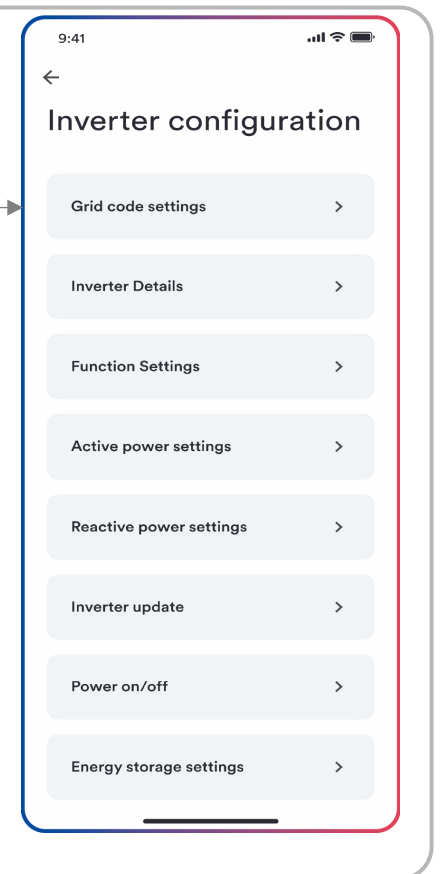
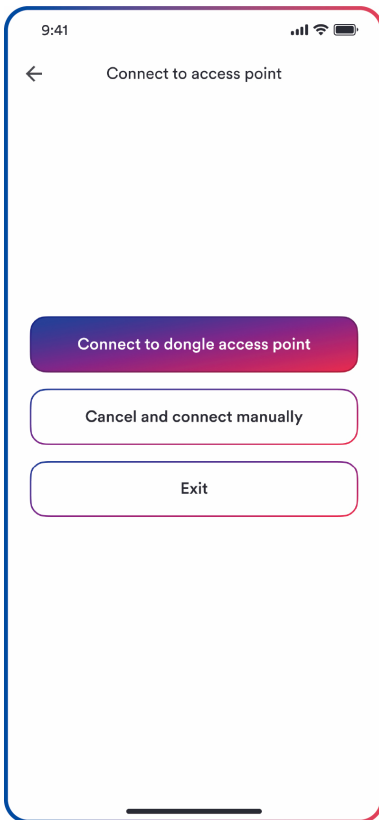

Step 5

Step 6

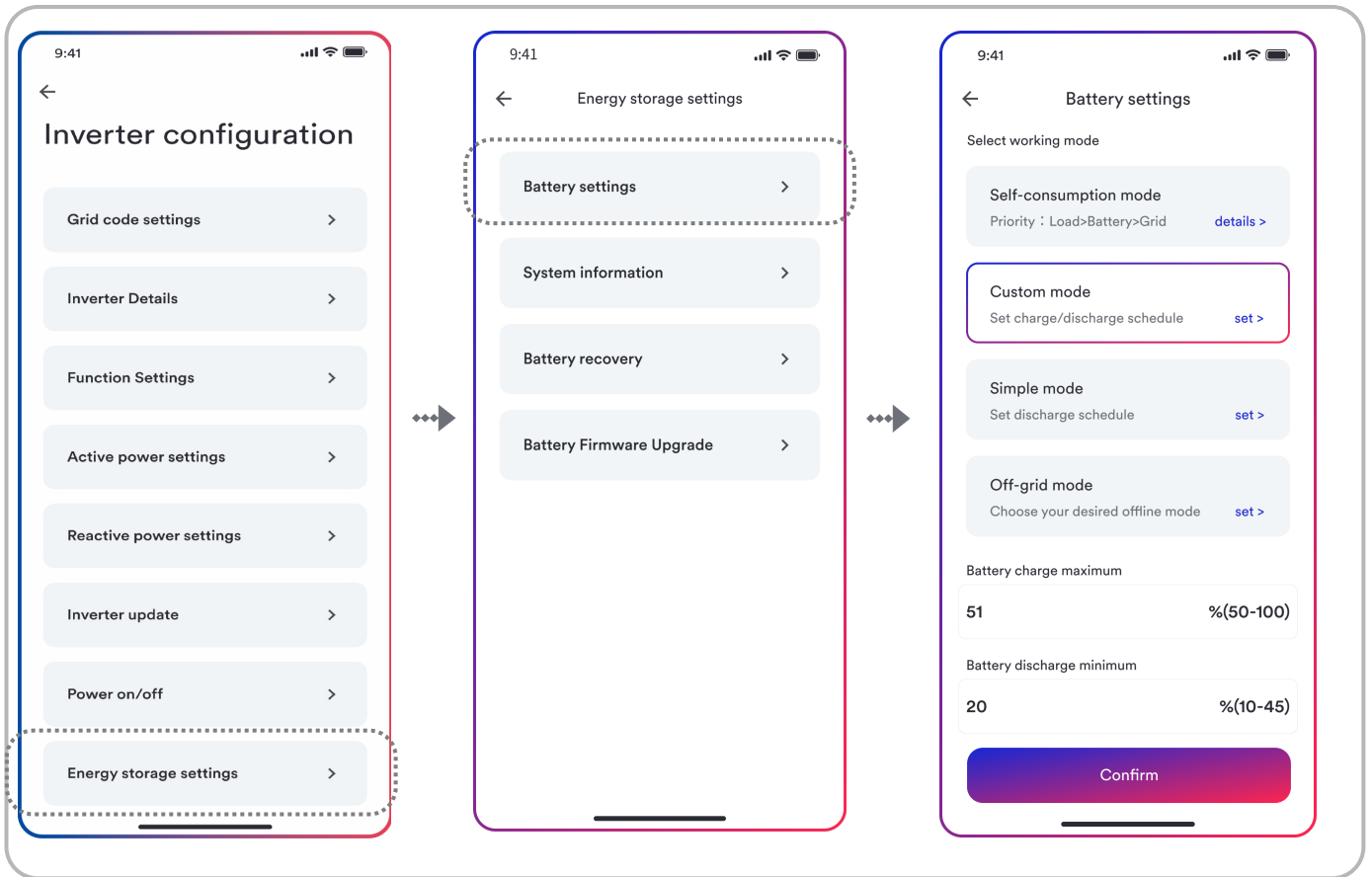

Step 7

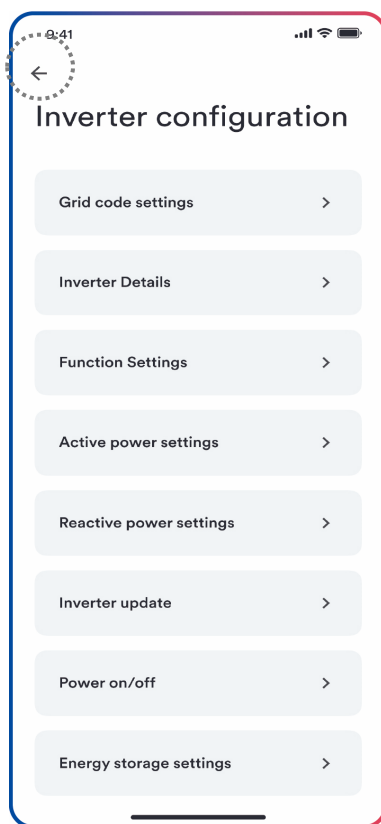

Step 8

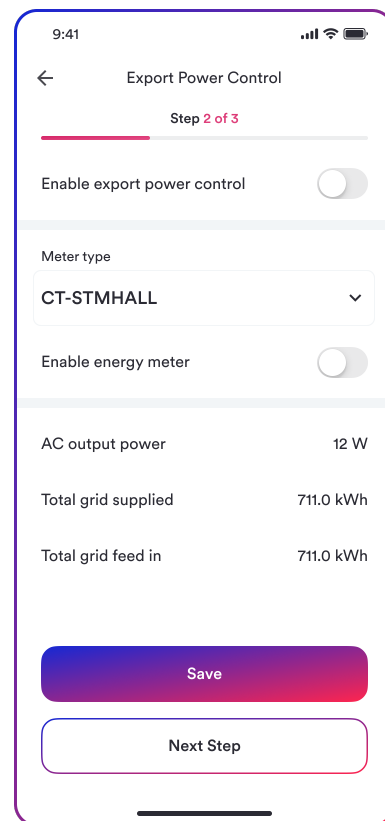

Step 9

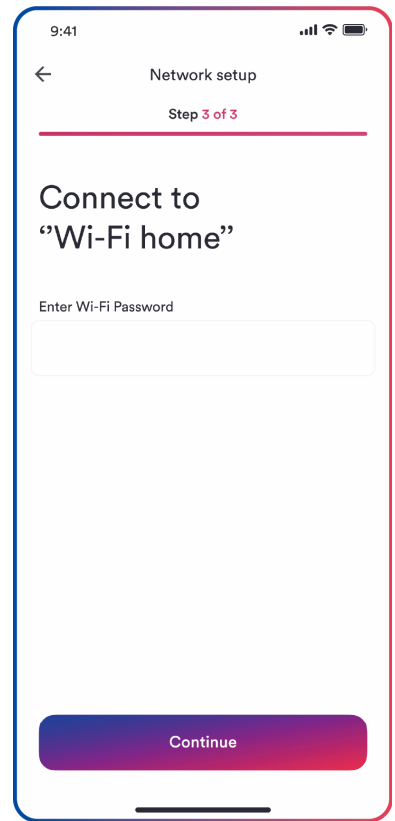
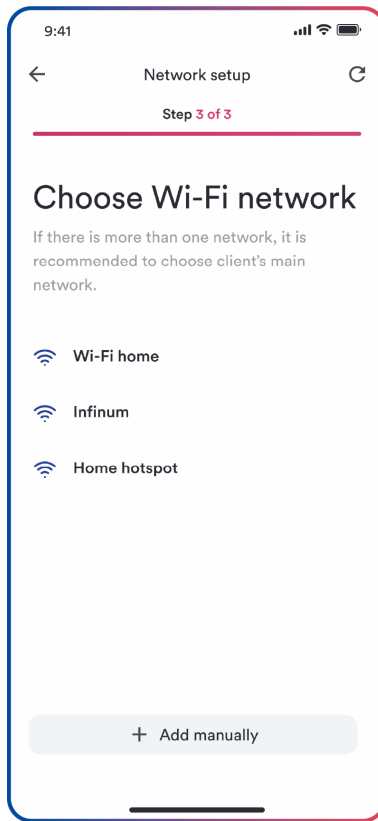
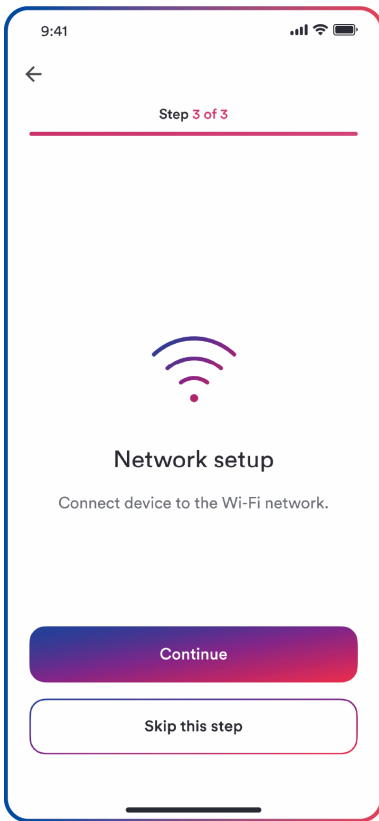

Step 10

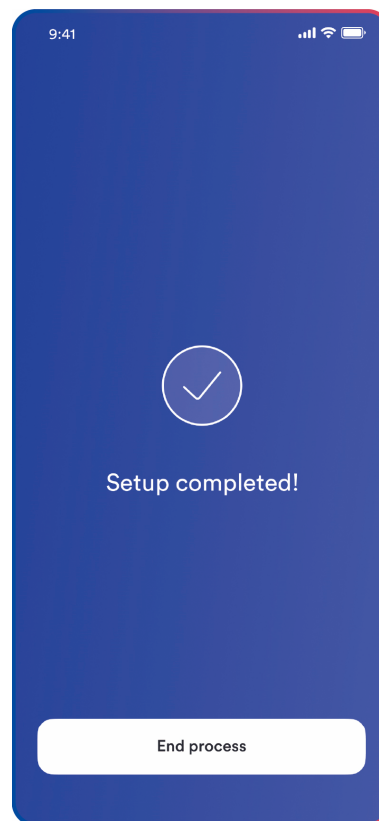
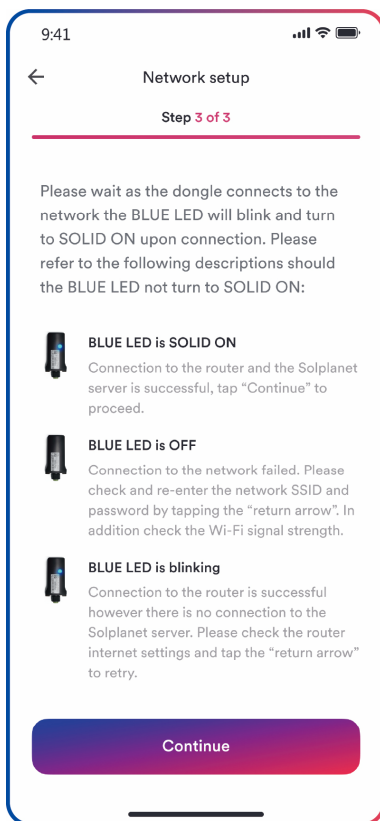

Step 11

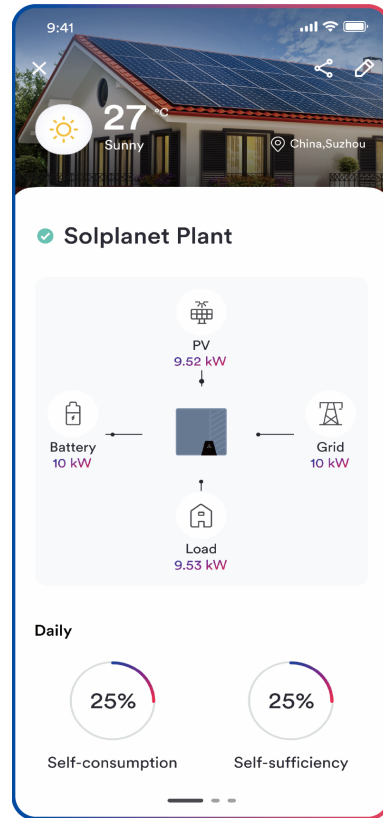
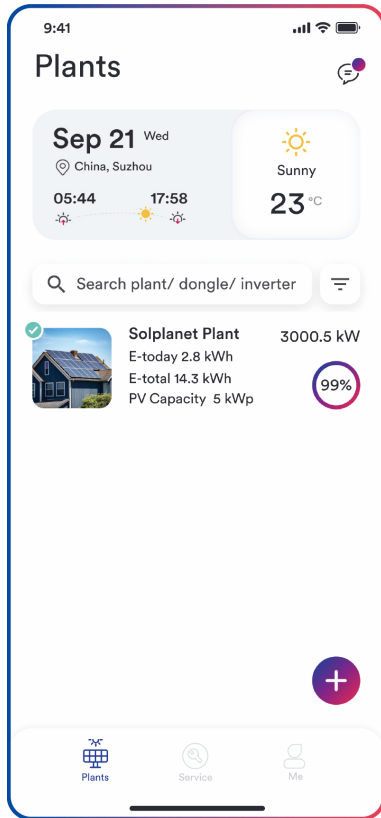

Step 12

## 8.5 Setting parameters

### 8.5.1 Inverter configuration

The Solplanet's products comply with local grid code when leaving the factory. But you still should check the grid code and the parameters according to the requirements of the installation site. Once configuration of the product is completed, the product will start operating automatically.

The Business user interface is shown in the following figure. The End user interface displays fewer parameters than Business users. If you have the relevant expertise, it is recommended that you choose Business users. Common users are advised to select End users.

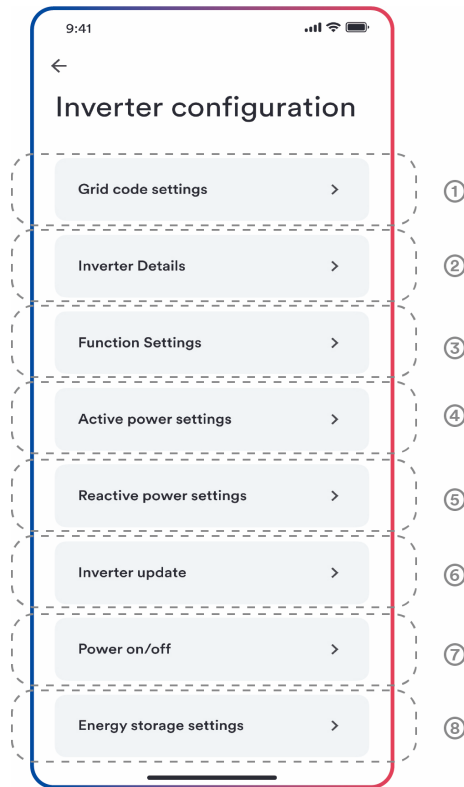

**Table description**

No.	Function	Description
①	Grid code settings	Choose a safety code. Configure the protection parameters. Configure the start operation parameters and automatic reconnection parameters.
②	Inverter Details	Show the general information of the inverter. Show the present operation value of the inverter.
③	Function settings	Active the general function. Active some special function.
④	Active power settings	Configure the parameters of the P(U) curve. Configure the parameters of the P(f) curve. Configure the parameters of the active power limited. Configure the parameters of the active power increasing and decreasing speed.
⑤	Reactive power settings	Choose the reactive power control mode. Configure the parameters of the Q (U) curve. Configure the parameters

		of the $\cos \varphi$ (P) curve. Configure the parameters of the fix Q value or fix $\cos \varphi$ value.
⑥	Inverter update	Update the firmware of the inverter and monitor device. Update the safety package.
⑦	Power on/off	Remote turn on/off the inverter on the App.
⑧	Energy storage settings	Configure the parameters of the Hybrid inverter. Configure the parameters of the battery.

## 8.5.2 Grid code settings



For the Australia market, the inverter cannot be connected to the grid before the safety related area is set. Please select from Australia Region A/B/C to comply with AS/NZS 4777.2:2020, and contact your local electricity grid operator on which Region to select.

Normally you only need choose the grid code from the support grid code list. The product has fully complied with the standards that are added in the list. If the local grid operator has the other requirement, you can can set the parameter according to the requirement after you get the approval.

### Procedure:

**Step 1:** Tap “Grid code setting” to enter to the next page.

**Step 2:** Swipe the smartphone screen to choose the right grid code, then tap “Save” and go back the previous page.

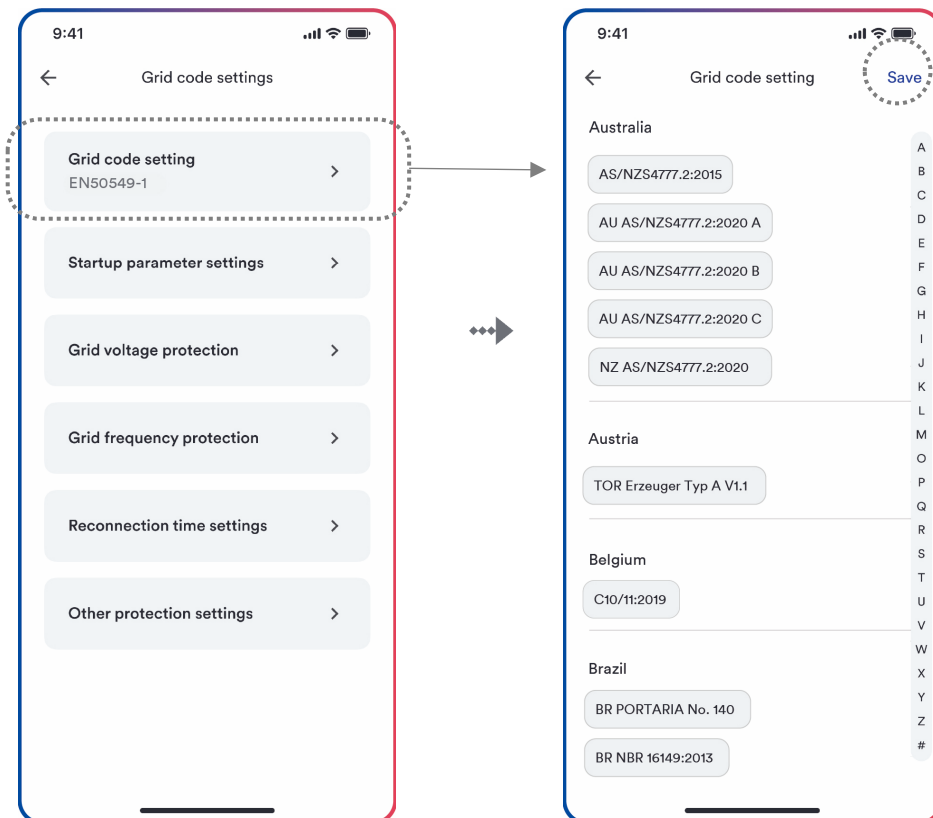

Step 1

Step 2

### 8.5.3 Active power reduction at overfrequency P(f)

There are four modes (Please refer to the following table) can be chosen for this function and many parameters can be configured according to the requirement of the local grid company.

**Procedure:**

**Step 1:** Tap “Active power settings” to enter to the next page.

**Step 2:** Tap “Overfrequency response settings” to enter to the next page.

**Step 3:** Tap the drop-down menu to choose the mode of this function.

**Step 4:** Configure the parameters and tap “Save”.



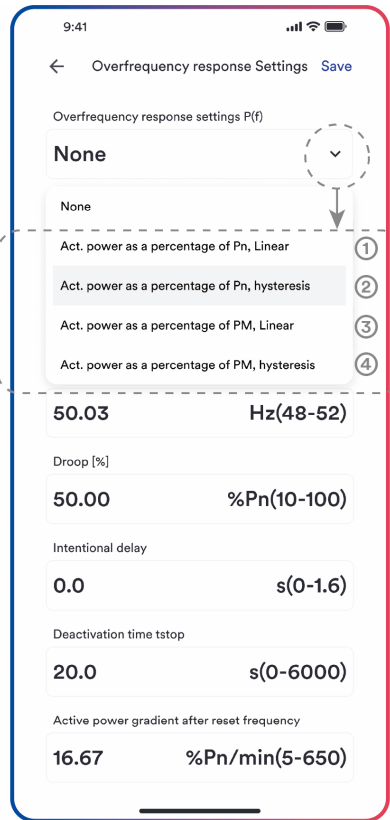

Step 3

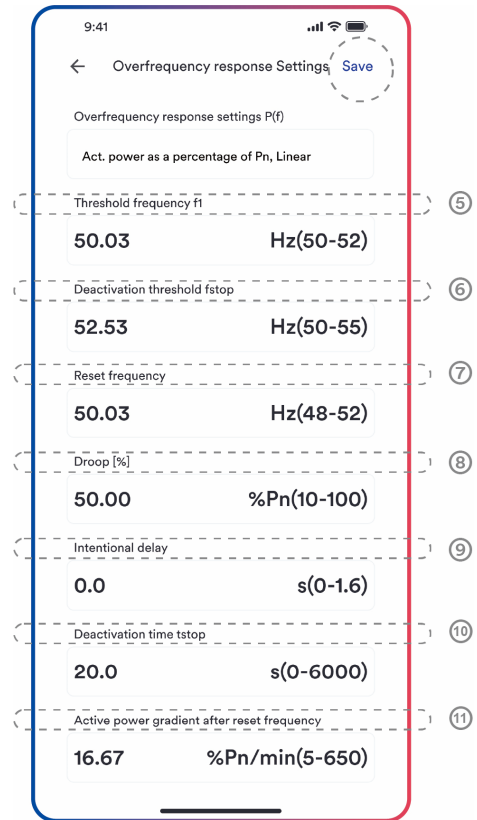

Step 4

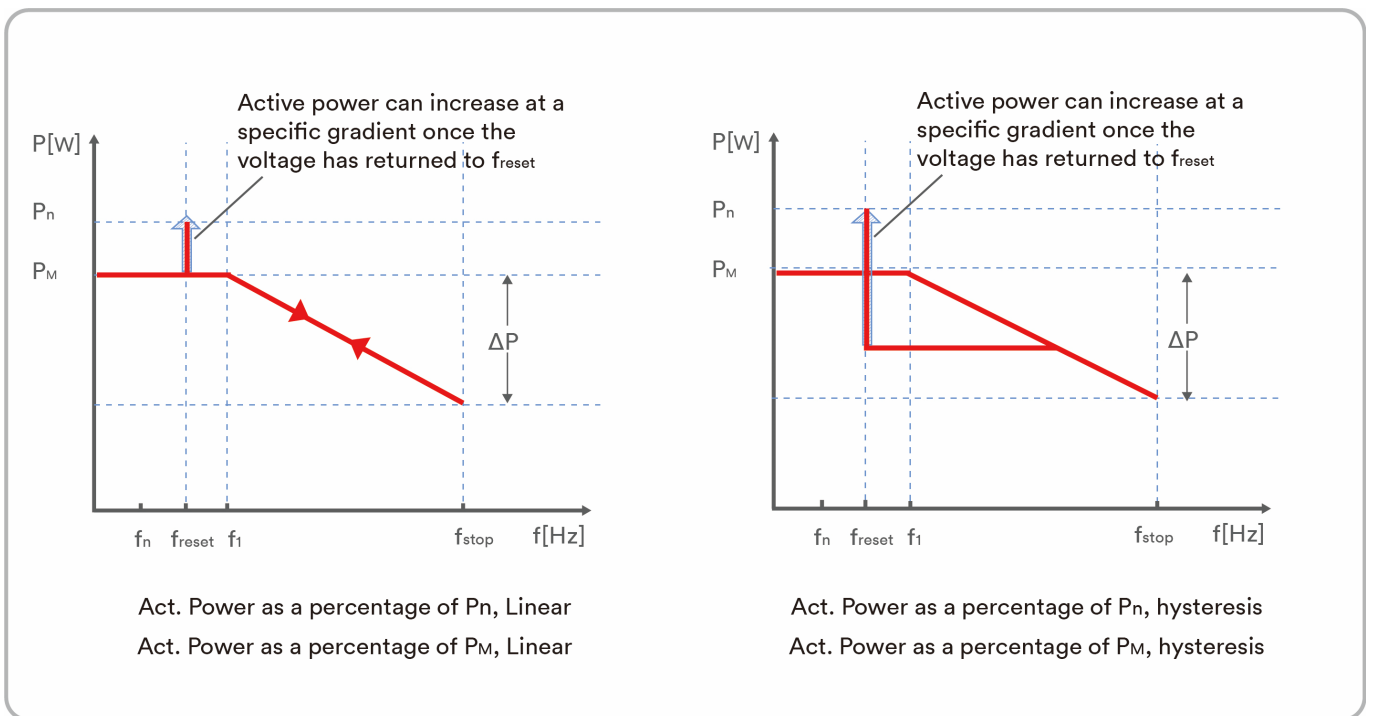



Table description

No.	Name	Description
①	Act. Power as a percentage of $P_n$ , Linear	Droop is defined as the active power as a percentage of $P_n$ . The active power will continuously move up and down the frequency characteristic curve in the frequency range of $f_1$ to $f_{stop}$ .
②	Act. Power as a percentage of $P_n$ , hysteresis	Droop is defined as the active power as a percentage of $P_n$ . The active power shall remain at or below the lowest power output level reached in response to the increase in frequency between $f_1$ to $f_{stop}$ .
③	Act. Power as a percentage of $P_M$ , Linear	Droop is defined as the active power as a percentage of $P_M$ . The active power will continuously move up and down the frequency characteristic curve in the frequency range of $f_1$ to $f_{stop}$ .
④	Act. Power as a percentage of $P_M$ , hysteresis	Droop is defined as the active power as a percentage of $P_M$ . The active power shall remain at or below the lowest power output level reached in response to the increase in frequency between $f_1$ to $f_{stop}$ .
⑤	Threshold frequency $f_1$	The threshold frequency for activating active power response to overfrequency.
⑥	Deactivation threshold $f_{stop}$	The threshold frequency for deactivating the active power response to overfrequency or disconnecting the inverter from the grid.
⑦	Reset frequency $f_{reset}$	The threshold frequency for deactivating the active power response to overfrequency after the frequency reducing.
⑧	Droop $\Delta P$	Reducing the active power in percentage of $P_n$ or $P_M$ when the frequency rise to $f_{stop}$ .
⑨	Intentional delay time	The delay time for activating active power response to overfrequency after the frequency over $f_1$ . An intentional delay shall be programmable to adjust the dead time to a value between the intrinsic dead time and 2s.
⑩	Deactivation time $t_{stop}$	The delay time that the active power can increase after the frequency below $f_{reset}$ .
⑪	Active power gradient	The active power increasing gradient as a percent of $P_n$ per minutes after the frequency reducing to $f_{reset}$ .



Here, the Droop is different from the Droop S in section 3.7.2 of the standard EN 50549-1.

If you want to configure the Droop S, the formula as below should be used to configure.

$$\Delta P = \frac{(f_{\text{stop}} - f_1) / f_n}{\text{Droop S}} \times 100$$

#### 8.5.4 Active power reduction at overvoltage P(U)

There are five modes (Please refer to the following table) can be chosen for this function and many parameters can be configured according to the requirement of the local grid company.

##### Procedure:

- Step 1:** Tap “Active power settings” to enter to the next page.
- Step 2:** Tap “Overvoltage response settings” to enter to the next page.
- Step 3:** Tap the drop-down menu to choose the mode of this function.
- Step 4:** Configure the parameters and tap “Save”.

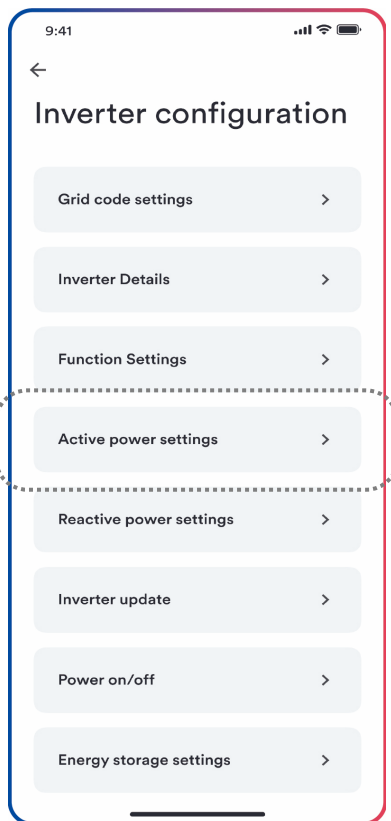

Step 1

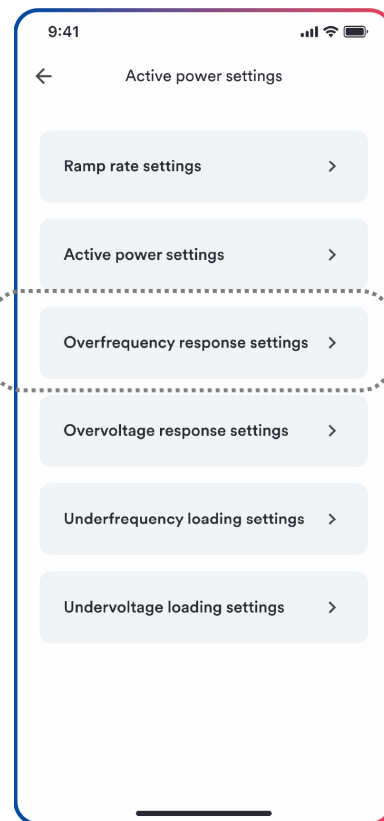

Step 2

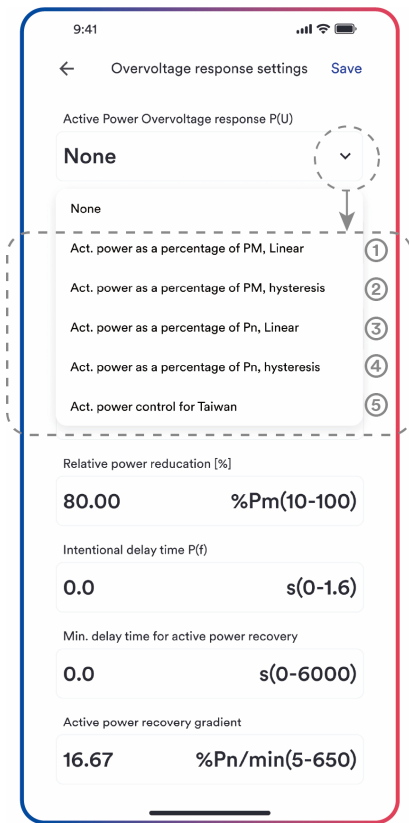

Step 3

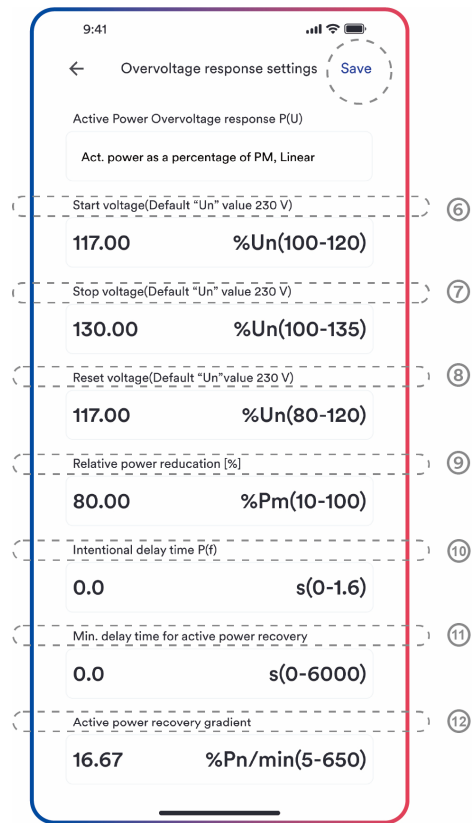

Step 4

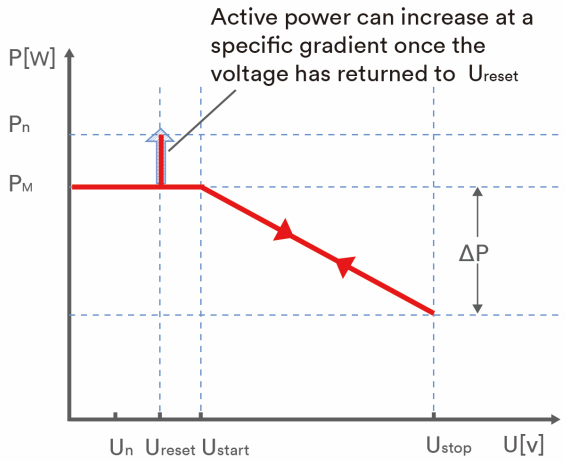

Act. Power as a percentage of  $P_M$ , Linear

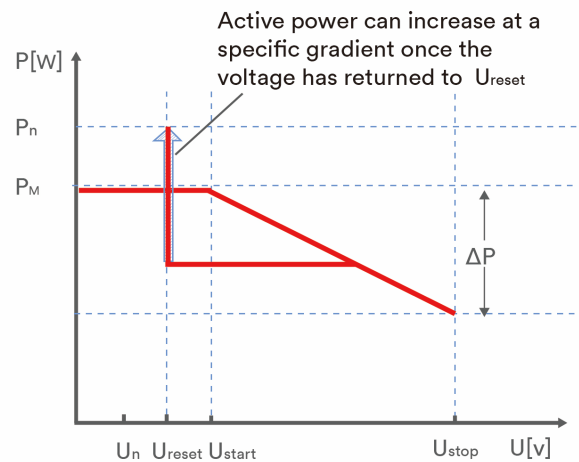

Act. Power as a percentage of  $P_M$ , hysteresis

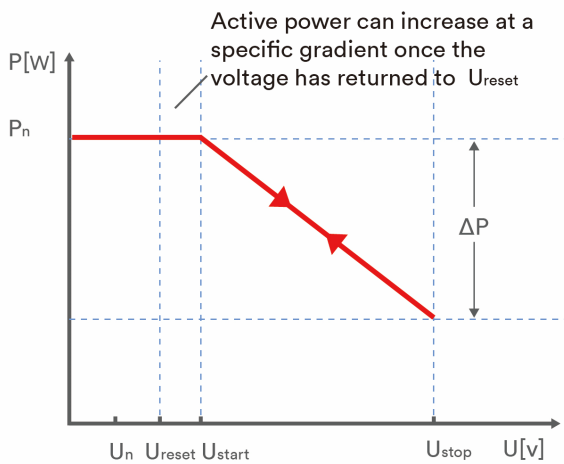

Act. Power as a percentage of  $P_n$ , Linear

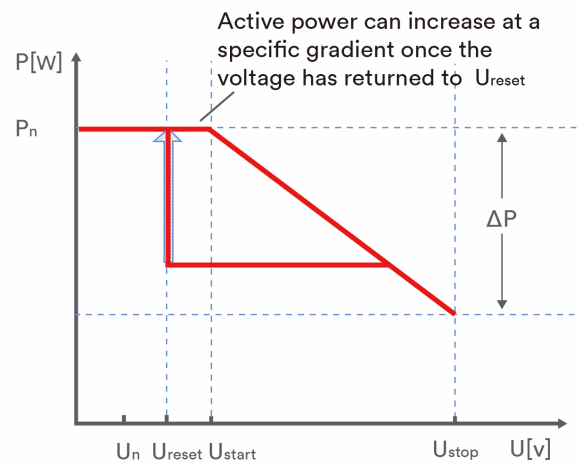

Act. Power as a percentage of  $P_n$ , hysteresis

**Table description**

No.	Name	Description
①	Act. Power as a percentage of $P_M$ , Linear	<p>Droop is defined as the active power as a percentage of <math>P_M</math>.</p> <p>The active power will continuously move up and down the voltage characteristic curve in the voltage range of <math>U_{start}</math> to <math>U_{stop}</math>.</p> <p>The active power reduce from the <math>P_M</math> that is the instantaneous active power at the time of exceeding Start voltage <math>U_{start}</math>.</p>
②	Act. Power as a percentage of $P_M$ , hysteresis	<p>Droop is defined as the active power as a percentage of <math>P_M</math>.</p> <p>The active power shall remain at or below the lowest</p>

		<p>power output level reached in response to the increase in voltage between <math>U_{start}</math> to <math>U_{stop}</math>.</p> <p>The active power reduce from the <math>P_M</math> that is the instantaneous active power at the time of exceeding Start voltage <math>U_{start}</math>.</p>
③	Act. Power as a percentage of $P_N$ , Linear	<p>Droop is defined as the active power as a percentage of <math>P_N</math>.</p> <p>The active power will continuously move up and down the voltage characteristic curve in the voltage range of <math>U_{start}</math> to <math>U_{stop}</math>.</p> <p>The active power reduce from the rated active power <math>P_n</math> at all time. The active power maybe don't reduce if the limited value of the curve is lower than the instantaneous active power at the time of exceeding Start voltage <math>U_{start}</math>.</p>
④	Act. Power as a percentage of $P_N$ , hysteresis	<p>Droop is defined as the active power as a percentage of <math>P_N</math>.</p> <p>The active power shall remain at or below the lowest power output level reached in response to the increase in the voltage range of <math>U_{start}</math> to <math>U_{stop}</math>.</p> <p>The active power reduce from the rated active power <math>P_n</math> at all time. The active power maybe don't reduce if the limited value of the curve is lower than the instantaneous active power at the time of exceeding Start voltage <math>U_{start}</math>.</p>
⑤	Act. Power control for Taiwan	Special control mode for Chinese Taiwan market.
⑥	Start voltage $U_{start}$	The threshold voltage for activating active power response to overvoltage.
⑦	Stop voltage $U_{stop}$	The threshold voltage for deactivating the active power response to overvoltage or disconnecting the inverter from the grid.
⑧	Reset voltage $U_{reset}$	<p>The threshold voltage for deactivating the active power response to overvoltage after the voltage reducing.</p> <p>Reset voltage does not work in the mode "Act. Power as a percentage of <math>P_N</math>, Linear".</p>
⑨	Droop $\Delta P$	Reducing the active power in percentage of $P_N$ or $P_M$ when the voltage rise to $U_{stop}$ .
⑩	Intentional delay time	The delay time for activating active power response to overvoltage after the voltage over $U_{start}$ . An intentional delay shall be programmable to adjust the dead time to a value between the intrinsic dead time and 2s.
⑪	Deactivation time $t_{stop}$	The delay time that the active power can increase after the voltage below $U_{reset}$ .
⑫	Active power gradient	The active power increasing gradient as a percent of $P_n$ per minutes after the frequency reducing to $f_{reset}$ .

## 8.5.5 $\cos\phi(P)$ curve configuration

The power related control mode  $\cos\phi(P)$  controls the  $\cos\phi$  of the output as a function of the active power output.

There are four coordinate points that can be configured. The coordinate points are the active power as a percentage of  $P_n$  and the displacement factor  $\cos\phi$ .

### Procedure:

- Step 1:** Tap “Reactive power settings” to enter to the next page.
- Step 2:** Tap “Enable reactive power” to choose the reactive power control mode and tap the left arrow to go back.
- Step 3:** Tap “ $\cos\phi(P)$  curve settings” to enter to the next page.
- Step 4:** Configure the parameters and tap “Save”.

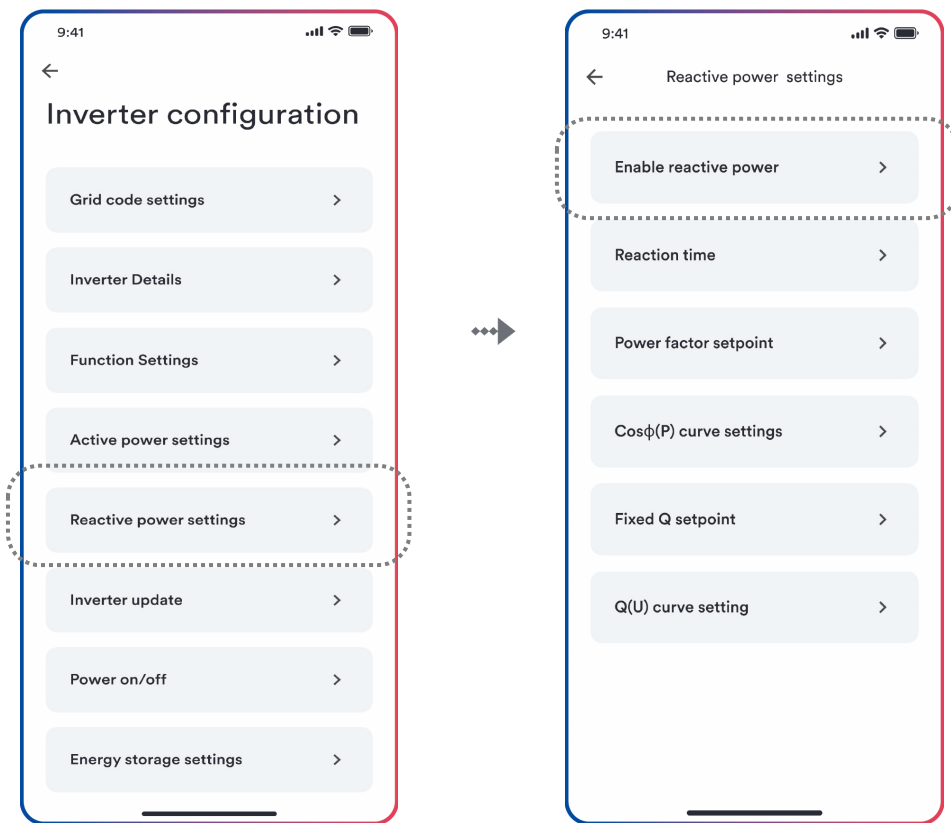

Step 1

Step 2

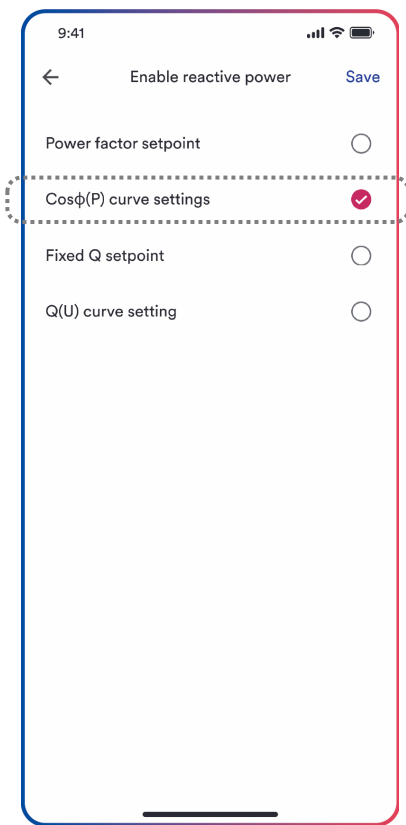

Step 3

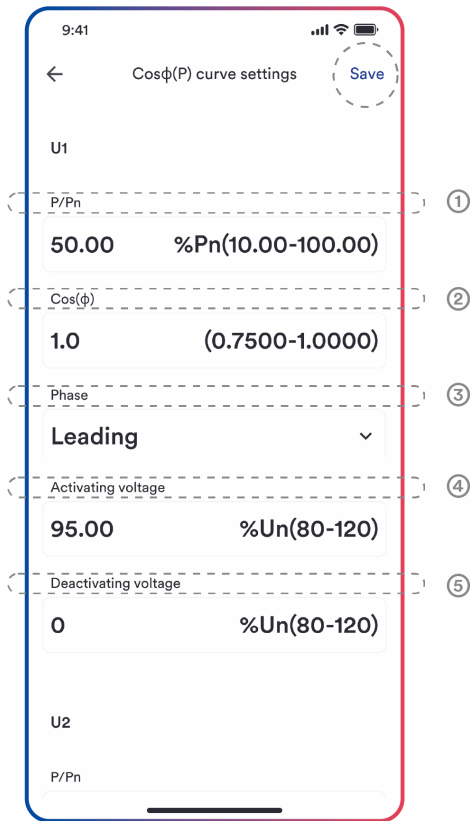

Step 4

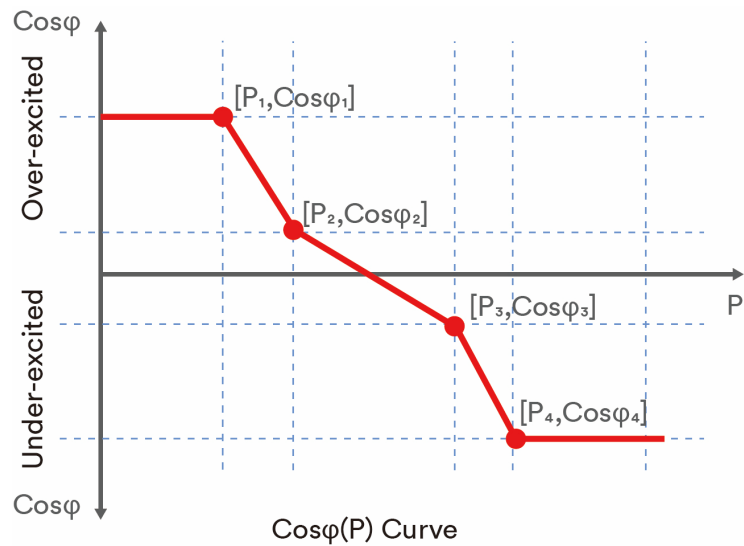

Cosφ(P) Curve

**Table description**

No.	Parameter	Description
①	P/P <sub>n</sub>	The active power as a percentage of P <sub>N</sub> .
②	Cosφ	The displacement factor that is cosine of the phase angle between the fundamental components of the line to neutral point voltage and the respective current.
③	Phase	Choose the over-excited or under-excited.

④	Activating voltage	<p>The lock-in voltage value that enables the automatic reactive power delivery mode.</p> <p>Activation threshold as a percentage of <math>U_n</math> corresponds to 'lock-in' voltage.</p>
⑤	Deactivating voltage	<p>The lock-out voltage value that disables the automatic reactive power delivery mode.</p> <p>Deactivation threshold as a percentage of <math>U_n</math> corresponds to 'lock-out' voltage</p>



Some grid companies may require two voltage thresholds as a percentage of  $U_n$  to activate or deactivate the function. The voltage thresholds normally call 'lock-in' and 'lock-out' voltage.

### 8.5.6 Q(U) curve configuration

The voltage related control mode Q(U) controls the reactive power output as a function of the voltage.

There are four coordinate points that can be configured. The coordinate points are the voltage as a percentage of  $U_n$  and the reactive power as a percentage of  $P_n$ .

#### Procedure:

**Step 1:** Tap "Reactive power settings" to enter to the next page.

**Step 2:** Tap "Enable reactive power" to choose the reactive power control mode and tap the left arrow to go back.

**Step 3:** Tap "Q(U) curve settings" to enter to the next page.

**Step 4:** Configure the parameters and tap "Save".



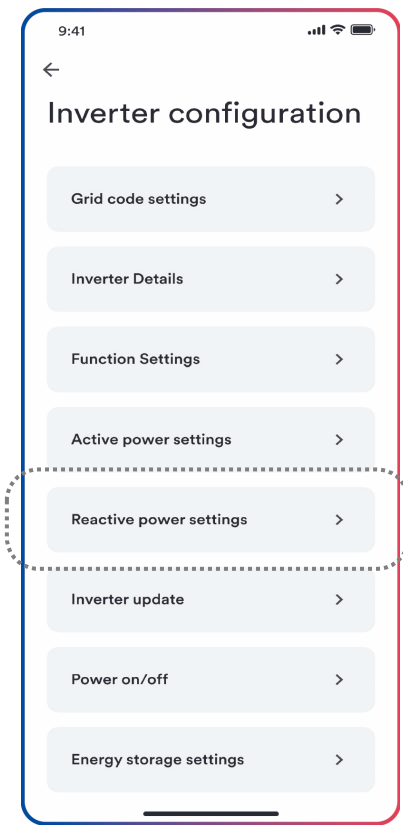

Step 1

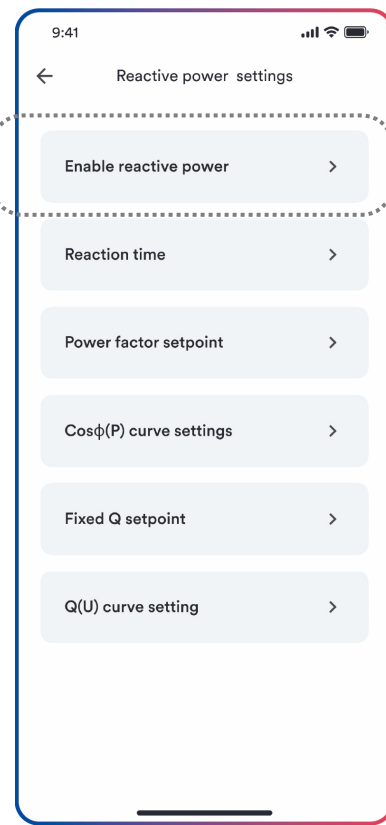

Step 2

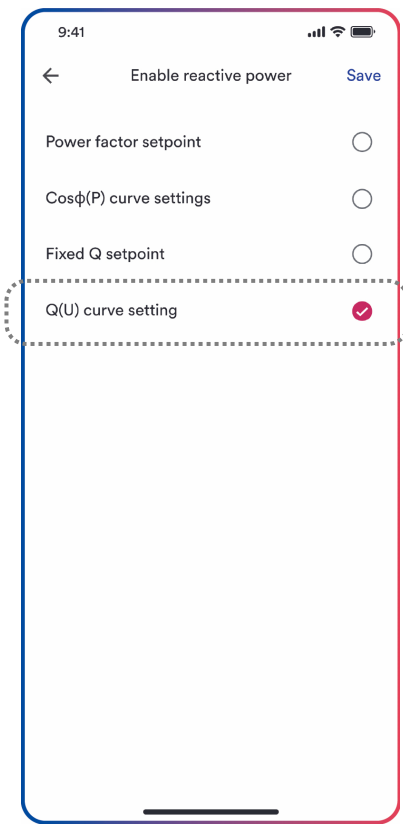

Step 3

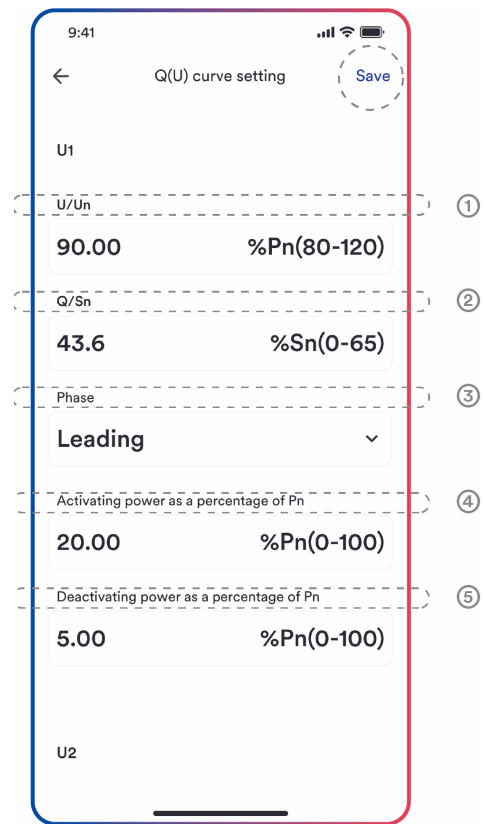

Step 4

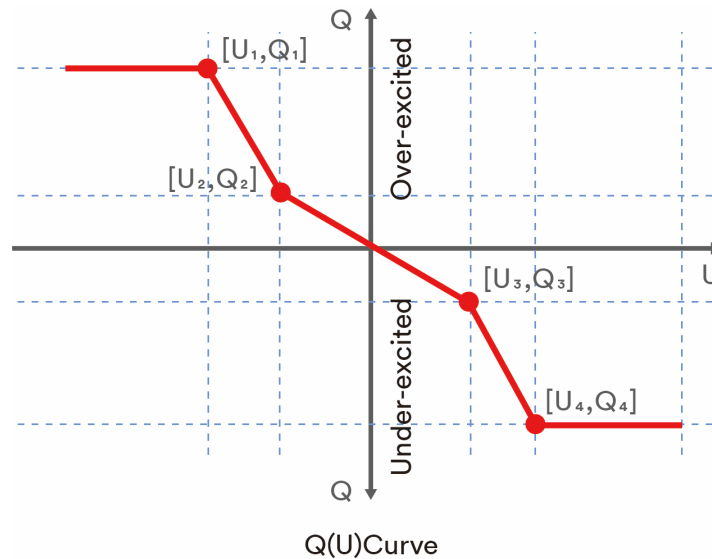

#### Table description

No.	Name	Description
①	$U/U_n$	The voltage as a percentage of $U_n$ .
②	$Q/P_n$	The reactive power as a percentage of $P_n$ .
③	Phase	Choose the over-excited or under-excited.
④	Activating power as a percentage of $P_n$	The lock-in active power value that enables the automatic reactive power delivery mode. Activation threshold as a percentage of $P_n$ corresponds to 'lock-in' power.
⑤	Deactivating power as a percentage of $P_n$	The lock-out active power value that disables the automatic reactive power delivery mode. Deactivation threshold as a percentage of $P_n$ corresponds to 'lock-out' power.



Some grid companies may require two active power thresholds as a percentage of  $P_n$  to activate or deactivate the function. The active power thresholds are normally called 'lock-in' and 'lock-out' active power.

## 9 Decommissioning the product

### 9.1 Disconnecting the inverter from voltage sources

#### **DANGER**

**Danger to life due to electric shock when touching exposed AC conductors if the AC connectors are damaged or loose!**

The AC connectors can break or become damaged, become free of the AC cables, or no longer be connected correctly if the AC connectors are released and disconnected incorrectly. This can result in the AC conductors being exposed. Touching live AC conductors will result in death or serious injury due to electric shock.

- Wear insulated gloves and use insulated tools when working on the AC connectors.
- Ensure that the AC connectors are in perfect condition and that none of the AC conductors are exposed.
- Carefully release and remove the AC connectors as described in the following.

Before performing any work on the machine, disconnect it from all voltage sources as described in this section. It is recommended to follow the given order.

#### Procedure:

**Step 1:** Turn off the circuit breaker and secure against reconnection.

**Step 2:** Press the battery button and hold for longer than 5s to power off the battery. Wait until the screen is off.

**Step 3:** Remove the cover refer to the step 1 of 6.3.1. AC cable connection.

**Step 4:** Use the flat-head screwdriver installation icon to flip the unlock lock and rotate the latch as shown.

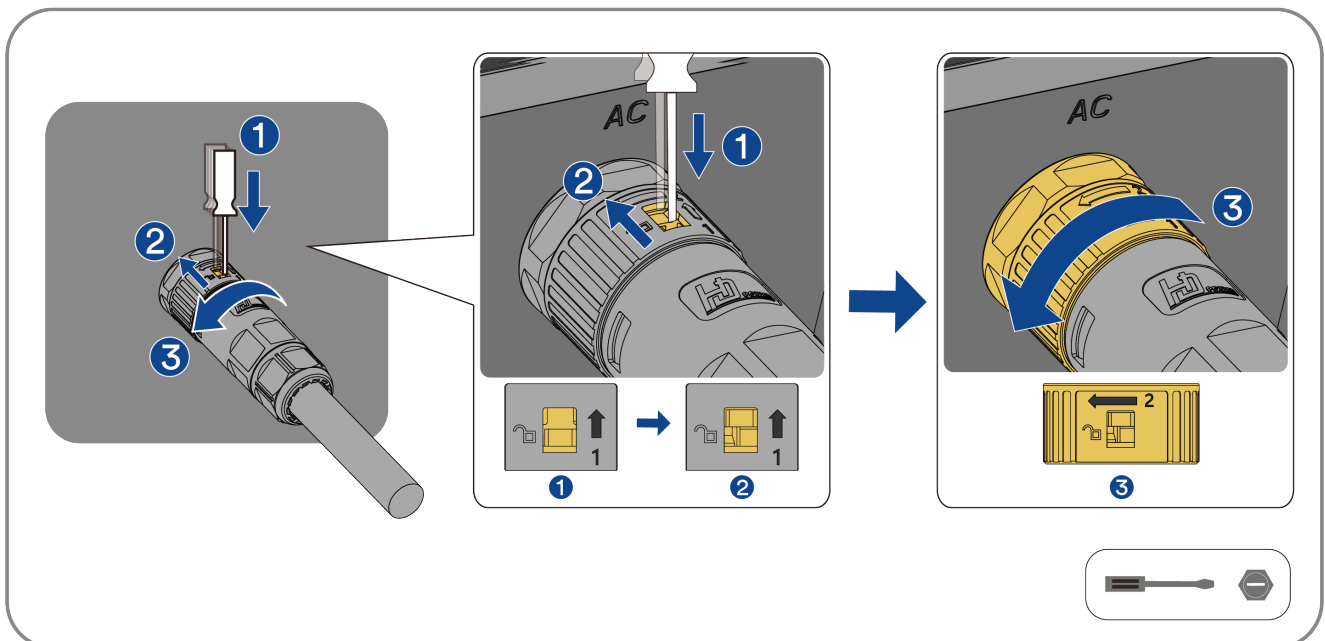

**Step 5:** Remove the female end of the cable to unlock the account.

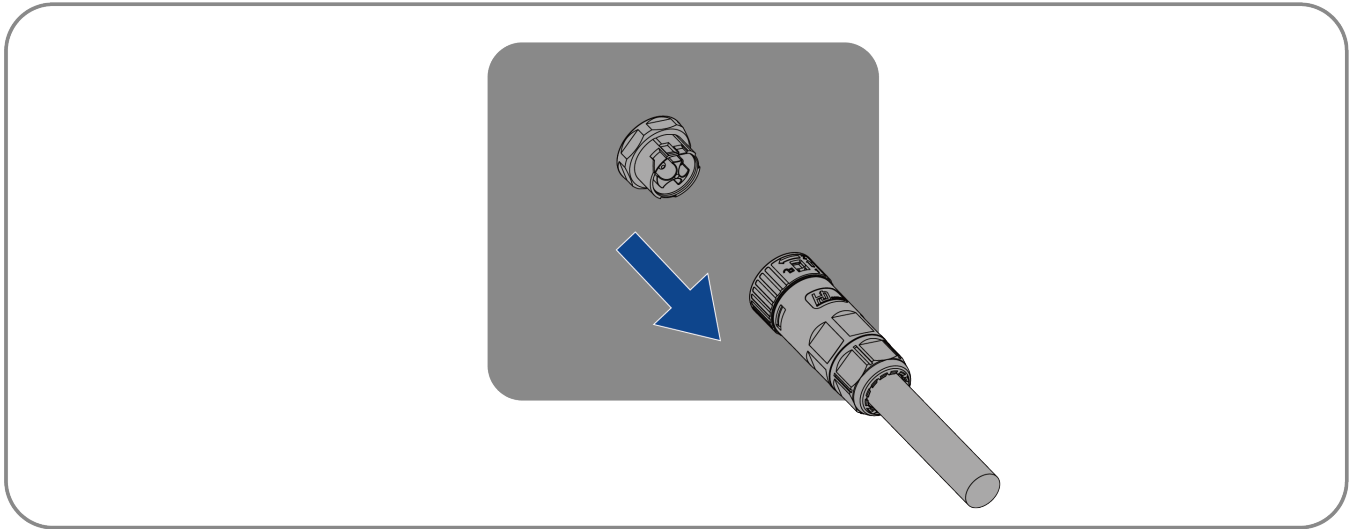

**Step 6:** Use a current clamp meter to ensure that no current is present in the DC cables.

**Step 7:** Release and remove the DC connectors. To do so, insert a flat-blade screwdriver or an angled screwdriver (blade width: 3.5 mm) into one of the side slots and pull the DC connectors out.

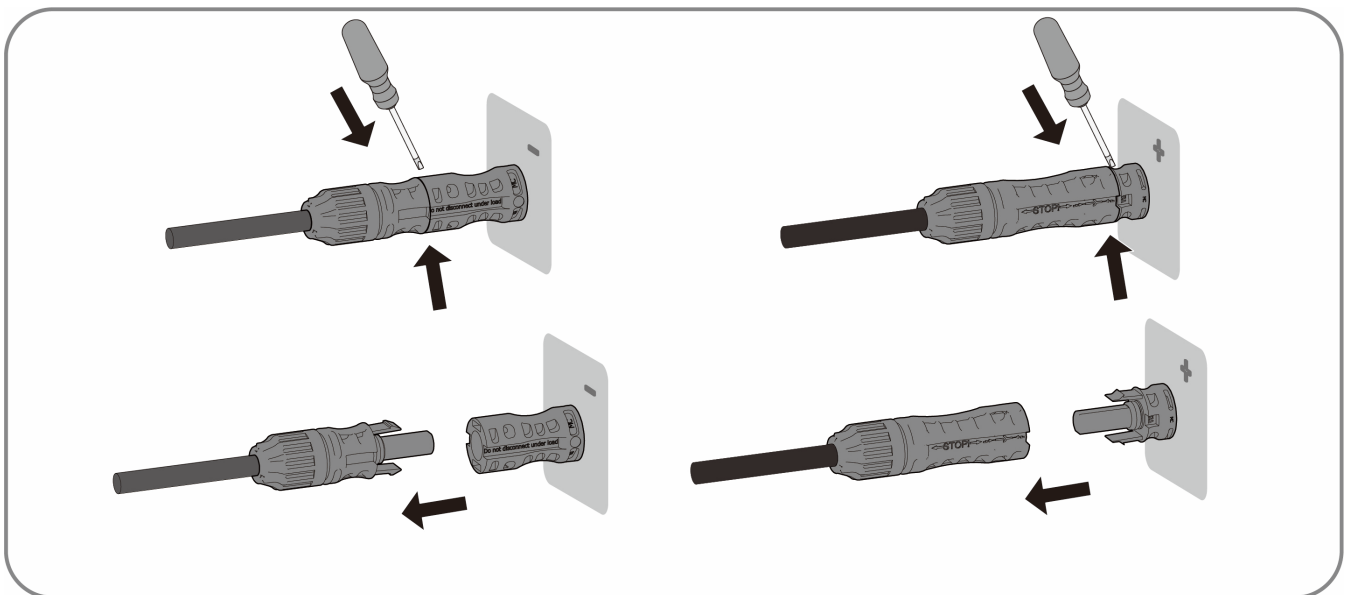

**Step 8:** Refer to 6.2.2 Communication cable connection to remove the network cable.

## 10 Technical data

### 10.1 ASW 0600-1000/1250A-S

Type	ASW 0600/1250A-S	ASW 0800/1250A-S	ASW 1000/1250A-S
<b>DC Input</b>			
Maximum power of PV array	2000 Wp	2000 Wp	2000 Wp
Maximum input voltage	50 V		
MPP voltage range	16-50 V		
MPP voltage range at P <sub>nom</sub>	36-50 V		
Rated input voltage	40 V		
Minimum input voltage	26 V		
Start voltage	30 V		
Max. operating input current per MPPT	28 A		
Max. short circuit current per MPP	39 A		
Maximum reverse current into the PV modules	39 A		
Number of independent MPP inputs	2	2	2
Strings per MPP input	2		
Overvoltage category in accordance with IEC 60664-1	II		
<b>AC Input and Output</b>			
Rated output power at 230 V	600 W	800 W	1000 W
Rated apparent power at $\cos\varphi = 1$	600 VA	800 VA	1000 VA
Maximum apparent power at $\cos\varphi = 1$	600 VA	800 VA	1000 VA
Rated grid voltage	220/230/240 V		
Grid voltage range	154-276 V		
Rated grid frequency	50 Hz/60 Hz		
Grid frequency range	45-55 Hz, 55-65 Hz		
Rated output current at 220 V	2.7 A	3.7 A	4.6 A
Rated output current at 230 V	2.6 A	3.5 A	4.4 A
Rated output current at 240 V	2.5 A	3.4 A	4.2 A
Maximum output current	2.8 A	3.8 A	4.8 A
Max. input power from grid	1000 W		
Max. input current from grid	4.8 A		
Inrush current	<20% of nominal AC current for a maximum of 10 ms		
Contribution to peak short-circuit current $i_p$	13 A		
Initial short-circuit alternating current (I <sub>k</sub> " first single period effective value)	2.6 A	3.5 A	4.4 A
Short circuit current continuous [ms] (max output fault current)	2.6 A	3.5 A	4.4 A
Recommended rated current of AC circuit Breaker	16 A		
Total harmonic distortion of the output current with total harmonic distortion of the AC voltage <2%, and AC power >50% of the rated power	<3%		
Power factor at rated power	≥0.99		
Adjustable displacement power factor	0.8 leading to 0.8 lagging		

Feed-in phase	1		
Connection phase	1		
Overtoltage category in accordance with IEC 60664-1	III		
Efficiency			
Maximum efficiency	92.0%		
European weighted efficiency	87.0%		
Battery data			
Max charging power	1000 W		
Max discharging power	1000 W		
Battery voltage range	37.5~60 V		
Max charging current	18 A		
Max discharging current	18 A		
Rated charging current	13.5 A		
Rated discharging current	13.5 A		
Battery type	LiFePO4		
Off-grid Data			
Rated apparent power at 230 V	1000 VA		
Max. Continuous apparent power at 230 V	1000 VA		
Max. apparent power at 230 V <60 s	1600 VA		
Nominal AC voltage	220/230/240 V		
AC grid frequency	50 Hz/60 Hz		
Max. continuous output current	2.8 A	3.8 A	4.8 A
Max. output current < 60s	6.9 A		
Total harmonic distortion (THDv, linear load)	2%		

(1) The voltage range meets the requirements of the corresponding national grid code.

(2) The frequency range meets the requirements of the corresponding national grid code.

## 10.2 ASW 0600-1000/2500A-S

Type	ASW 0600/2500A-S	ASW 0800/2500A-S	ASW 1000/2500A-S
DC Input			
Maximum power of PV array	2000 Wp	2000 Wp	2000 Wp
Maximum input voltage	50 V		
MPP voltage range	16-50 V		
MPP voltage range at P <sub>nom</sub>	36-50 V		
Rated input voltage	40 V		
Minimum input voltage	26 V		
Start voltage	30 V		
Max. operating input current per MPPT	28 A		
Max. short circuit current per MPP	39 A		
Maximum reverse current into the PV modules	39 A		
Number of independent MPP inputs	2	2	2
Strings per MPP input	2		

Overvoltage category in accordance with IEC 60664-1	II		
<b>AC Input and Output</b>			
Rated output power at 230 V	600 W	800 W	1000 W
Rated apparent power at $\cos\varphi = 1$	600 VA	800 VA	1000 VA
Maximum apparent power at $\cos\varphi = 1$	600 VA	800 VA	1000 VA
Rated grid voltage	220/230/240 V		
Grid voltage range	154-276 V		
Rated grid frequency	50 Hz/60 Hz		
Grid frequency range	45-55 Hz, 55-65 Hz		
Rated output current at 220 V	2.7 A	3.7 A	4.6 A
Rated output current at 230 V	2.6 A	3.5 A	4.4 A
Rated output current at 240 V	2.5 A	3.4 A	4.2 A
Maximum output current	2.8 A	3.8 A	4.8 A
Max. input power from grid	1000 W		
Max. input current from grid	4.8 A		
Inrush current	<20% of nominal AC current for a maximum of 10 ms		
Contribution to peak short-circuit current $i_p$	13 A		
Initial short-circuit alternating current ( $I_k$ first single period effective value)	2.6 A	3.5 A	4.4 A
Short circuit current continuous [ms] (max output fault current)	2.6 A	3.5 A	4.4 A
Recommended rated current of AC circuit Breaker	16 A		
Total harmonic distortion of the output current with total harmonic distortion of the AC voltage <2%, and AC power >50% of the rated power	<3%		
Power factor at rated power	≥0.99		
Adjustable displacement power factor	0.8 leading to 0.8 lagging		
Feed-in phase	1		
Connection phase	1		
Overvoltage category in accordance with IEC 60664-1	III		
<b>Efficiency</b>			
Maximum efficiency	92.0%		
European weighted efficiency	87.0%		
<b>Battery data</b>			
Max charging power	1600 W		
Max discharging power	1000 W		
Battery voltage range	37.5~60 V		
Max charging current	36 A		
Max discharging current	26 A		
Rated charging current	13.5 A		
Rated discharging current	13.5 A		
Battery type	LiFePO4		
<b>Off-grid Data</b>			
Rated apparent power at 230 V	1000 VA		

Max. Continuous apparent power at 230 V	1000 VA		
Max. apparent power at 230 V <60 s	1600 VA		
Nominal AC voltage	220/230/240 V		
AC grid frequency	50 Hz/60 Hz		
Max. continuous output current	2.8 A	3.8 A	4.8 A
Max. output current < 60s	6.9 A		
Total harmonic distortion (THDv, linear load)	2%		

(1) The voltage range meets the requirements of the corresponding national grid code.

(2) The frequency range meets the requirements of the corresponding national grid code.

### 10.3 General data

Type	ASW 0600-1000/1250A-S	ASW 0600-1000/2500A-S
Width × height × depth	600 mm ×400 mm ×310mm	
Weight	31 kg	38 kg
Topology	Isolated	
Operating temperature range	-15°C ... +45°C	
Allowable relative humidity range (non-condensing)	95%	
Degree of protection for electronics in accordance with IEC 60529	IP55	
Climatic category in accordance with IEC 60721-3-4	3K3	
Protection class (according to IEC 62103)	I	
Pollution degree outside the enclosure	3	
Pollution degree inside the enclosure	2	
Max. operating altitude above mean sea level	3000 m	
Self-consumption (night)	<7 W	
Cooling method	Fan Cooling	
Typical noise emission	35 dB	
Display	LCD	
Demand response mode in accordance with AS/NZS 4777.2	DRM0	
Zero power output	Via connecting CT	
Earth Fault Alarm	●	
Interfaces	LCD & App	
Communication	Ai-Dongle	
Radio technology	WLAN 802.11 b/g/n	
Radio spectrum	2.4 GHz	
Maximum transmission power	100 mW	



## 10.4 Protective device

Type	ASW 0600-1000/1250A-S ASW 0600-1000/2500A-S
DC reverse polarity protection	Integrated
Ground fault monitoring	Integrated
AC short- circuit current capability	Integrated
Active anti-islanding protection	Integrated
PV string current monitoring	Integrated
DC current injection monitoring	Integrated
Low voltage ride through	Integrated
High voltage ride through	Integrated



Please take into account the Voc temperature co-efficient when choosing an appropriate solar panel.

## 11 Troubleshooting

When the PV system does not operate normally, we recommend the following solutions for quick troubleshooting. If an error or warning occurs, there will have "Event Messages" display in the LCD screen and monitor tools. The corresponding corrective measures are as follows:

Error code	Message	Corrective measures
1	Communication Fails between M-S	<ul style="list-style-type: none"> <li>Shut down the device in the APP first, unplug the PV terminal and disconnect the AC connection, manually close the battery button (5s long press) until the battery button indicator is off, and then plug the PV terminal again, connect the AC cable, and start the device in the APP.</li> <li>If the fault has not been removed, please contact 400-801-9996 or the public account of Aiswei Service Center for online consultation.</li> </ul>
3	Relay check Fail	<ul style="list-style-type: none"> <li>Shut down the device in the APP first, unplug the PV terminal and disconnect the AC connection, manually close the battery button (5s long press) until the battery button indicator is off, and then plug the PV terminal again, connect the AC cable, and start the device in the APP</li> <li>If the fault has not been removed, please contact 400-801-9996 or the public account of Aiswei Service Center for online consultation.</li> </ul>
5	The result of Auto Test Function is fail	<ul style="list-style-type: none"> <li>Shut down the device in the APP first, unplug the PV terminal and disconnect the AC connection, manually close the battery button (5s long press) until the battery button indicator is off, and then plug the PV terminal again, connect the AC cable, and start the device in the APP.</li> <li>If the fault has not been removed, please contact 400-801-9996 or the public account of Aiswei Service Center for online consultation.</li> </ul>
11	M-S version unmatched	<ul style="list-style-type: none"> <li>Please upgrade the latest version of DSP program.</li> <li>Please contact 400-801-9996 or the public account of Aishvi Service Center for online consultation.</li> </ul>
33	Fac Failure: -Fac Out of Range	<ul style="list-style-type: none"> <li>Check the type of safety code on the display screen and confirm whether it is consistent with the local power grid.</li> <li>Shut down the device in the APP first, unplug the PV terminal and disconnect the AC connection, manually close the battery button (5s long press) until the battery button indicator is off, and then plug the PV terminal again, connect the AC cable, and start the device in the APP.</li> <li>If the fault has not been removed, please contact 400-801-9996 or the public account of Aiswei Service Center for online consultation.</li> </ul>
34	AC Voltage Out of Range	<ul style="list-style-type: none"> <li>Disconnect the AC air switch and measure the AC voltage. It should be the voltage between line and the neutral(the value is about 230V), and the voltage between neutral and the ground (the value is within 20V).</li> <li>If the measured voltage is abnormal, the failure is caused by the system voltage. If the measured voltage is normal, please switch on the air switch and proceed to the next step.</li> <li>Measure the AC voltage UL1-N, UL2-N, UL3-N, UN-PE by multimeter.</li> <li>If the measured voltage is normal, it is caused by the inverter fault, please contact with service center.</li> <li>If the measured voltage exceeds the safety requirement, please check system voltage.</li> </ul>
35	Utility Loss	<ul style="list-style-type: none"> <li>Make sure the grid power is disconnected when the HESA is in off-grid mode.</li> <li>If this fault is still being displayed, contact the service.</li> </ul>

37	PV Over Voltage	<ul style="list-style-type: none"> <li>The failure will appear when the inverter detects that the system input DC voltage exceeds the inverter max DC voltage.</li> <li>Remove all the strings from inverter, and use the multimeter to measure the voltage between PV+ and PV- for each string. All the voltage shall not exceed the inverter max DC voltage.</li> <li>If the measured voltage is normal, it may be caused by the inverter fault, please contact with service center</li> </ul>
40	Over temperature in inverter	<ul style="list-style-type: none"> <li>Check the type of safety code on the display screen and confirm whether it is consistent with the local power grid.</li> <li>Shut down the device in the APP first, unplug the PV terminal and disconnect the AC connection, manually close the battery button (5s long press) until the battery button indicator is off, and then plug the PV terminal again, connect , the AC cable, and start the device in the APP.</li> <li>If the fault has not been removed, please contact 400-801-9996 or the public account of Aiswei Service Center for online consultation.</li> </ul>
65	PE connection Fault	<ul style="list-style-type: none"> <li>This fault is reported when the inverter detects that the neutral line voltage to earth exceeds 20V.</li> <li>Use a multimeter to measure the voltage between the neutral wire and the ground wire of the inverter (theoretical value within 20V).</li> <li>If the protection voltage range is exceeded, make sure that the system ground wire is not loose, the connection is not tight, and the contact area of the connection is not sufficient.</li> <li>If the problem cannot be solved, please contact the service hotline 400-801-9996 or the official account of the service center for online consultation.</li> </ul>
66	PV1 string reverse Connection fault	<ul style="list-style-type: none"> <li>Check whether the positive and negative polarity of the input terminals of the PV 1 is reversed.</li> <li>If the problem cannot be solved, please contact the service hotline 400-801-9996 or the public account of the Ashvi Service Center for online consultation.</li> </ul>
67	PV2 string reverse Connection fault	<ul style="list-style-type: none"> <li>Check whether the positive and negative polarity of the input terminals of the PV 2 is reversed.</li> <li>If the problem cannot be solved, please contact the service hotline 400-801-9996 or the public account of the Ashvi Service Center for online consultation.</li> </ul>
68	PV3 string reverse Connection fault	<ul style="list-style-type: none"> <li>Check whether the positive and negative polarity of the input terminals of the PV 3 is reversed.</li> <li>If the problem cannot be solved, please contact the service hotline 400-801-9996 or the public account of the Ashvi Service Center for online consultation.</li> </ul>
74	Grid Remain under OFF-Grid Mode	<ul style="list-style-type: none"> <li>This fault is reported only in off-grid mode.</li> <li>Please make sure to disconnect the grid voltage first and set it to off-grid mode in APP or display screen.</li> <li>If the problem cannot be solved, please contact the service hotline 400-801-9996 or the public account of the Service center for online consultation.</li> </ul>
75	PV4 string reverse Connection fault	<ul style="list-style-type: none"> <li>Check whether the positive and negative polarity of the input terminals of the PV 4 is reversed.</li> <li>If the problem cannot be solved, please contact the service hotline 400-801-9996 or the public account of the Ashvi Service Center for online consultation.</li> </ul>

## 12 Maintenance

### Cleaning air inlet and outlet

#### **CAUTION**

##### **Hot enclosure or heat sink may cause personal injury!**

When the inverter is working, the temperature of the enclosure or heat sink will be higher than 70°C, and the contact may cause burns.

- Before cleaning the air outlet, shut down the machine and wait for about 30 minutes until the temperature of the enclosure decreases to normal temperature.

A huge amount of heat is generated in the process of running the HESA. The HESA adopts a controlled forced-air cooling method. In order to maintain good ventilation, please check to make sure the air inlet and outlet are not blocked.

#### **Procedure:**

**Step 1:** Disconnect the AC side circuit breaker and ensure that it cannot be accidentally reconnected.

**Step 2:** Clean the air inlet and outlet of the HESA with a soft brush.

## 13 Recycling and disposal

Dispose of the packaging and replaced parts according to the rules applicable in the country where the device is installed.

Do not dispose the Solplanet HESA with normal domestic waste.



Do not dispose of the product together with the household waste but in accordance with the disposal regulations for electronic waste applicable at the installation site.

## 14 EU declaration of conformity

Within the scope of the EU directives

- Radio Equipment Directive 2014/53/EU (L 153/62-106. May 22. 2014) (RED)
- Restriction of the use of certain hazardous substances 2011/65/EU (L 174/88, June 8, 2011) and 2015/863/EU (L 137/10, March 31,2015) (RoHS)



AISWEI New Energy Technology (Yangzhong) Co., Ltd. confirms herewith that the inverters described in this manual are in compliance with the fundamental requirements and other relevant provisions of the above mentioned directives.

The entire EU Declaration of Conformity can be found at [www.solplanet.net](http://www.solplanet.net).

## 15 Service and warranty

If you have any technical problems concerning our products, please contact Solplanet service. We require the following information in order to provide you with the necessary assistance:

- Single phase All-in-one hybrid energy storage system type
- Single phase All-in-one hybrid energy storage system serial number
- Single phase All-in-one hybrid energy storage system battery type
- Type and number of connected PV modules
- Error code
- Mounting location
- Installation date
- Warranty card

The factory warranty card is enclosed with the package, please keep well the factory warranty card. Warranty terms and conditions can be downloaded at [www.solplanet.net](http://www.solplanet.net), if required. When the customer needs warranty service during the warranty period, the customer must provide a copy of the invoice, factory warranty card, and ensure the electrical label of the machine is legible. If these conditions are not met, Solplanet has the right to refuse to provide with the relevant warranty service.

## 16 Contact

### EMEA

Service email: [service.EMEA@solplanet.net](mailto:service.EMEA@solplanet.net)

### APAC

Service email: [service.APAC@solplanet.net](mailto:service.APAC@solplanet.net)

### LATAM

Service email: [service.LATAM@solplanet.net](mailto:service.LATAM@solplanet.net)

AISWEI Pty Ltd.

Hotline: +61 390 988 674

Add.: Level 40, 140 William Street, Melbourne VIC 3000, Australia

AISWEI B.V.

Hotline: +31 208 004 844 (Netherlands)

+48 134 926 109 (Poland)

Add.: Barbara Strozilaan 101,5e etage,kantoornummer 5.12,1083HN Amsterdam,the Netherlands

AISWEI New Energy Technology (Yangzhong) Co., Ltd.

Hotline: +86 400 801 9996

Add.: No.588 Gangxing Road, Yangzhong Jiangsu, China

<https://solplanet.net/contact-us/>

Scan QR code:



Android

Scan QR code:



iOS

