

Smart EV Charger User Manual

SOL APOLLO Series

SOL7.4H-WP / SOL7.4H-WS / SOL7.4H-WSS / SOL11H-WP /
SOL11H-WS / SOL11H-WSS / SOL22H-WP / SOL22H-WS /
SOL22H-WSS

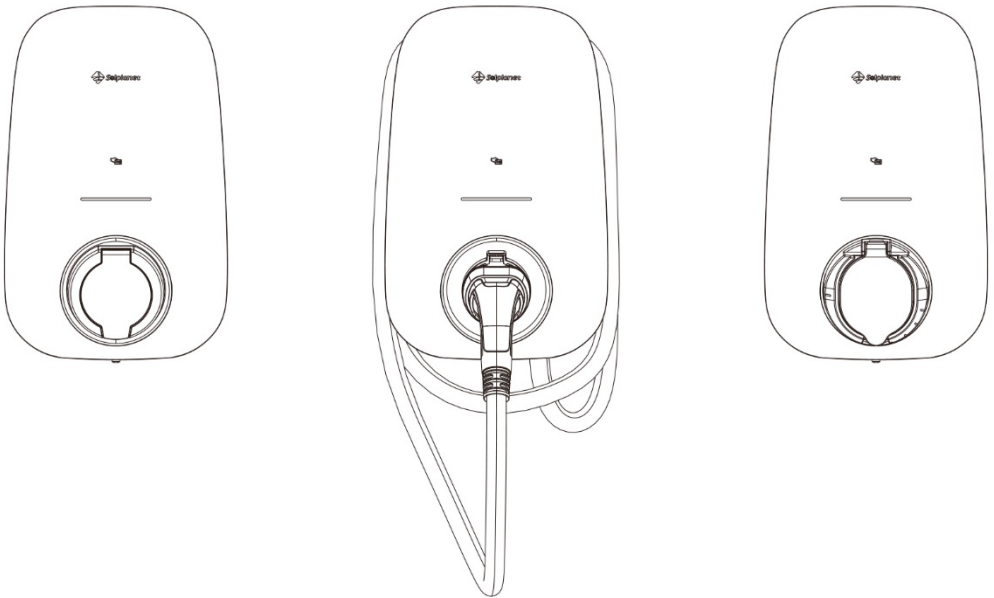

Thank you for choosing our Solplanet Smart EV Charger.

The Solplanet Smart EV Charger is an AC power charging station, it supplies AC power to chargers: SOL7.4H, SOL11H, SOL22H.

Please read and follow the instructions in this manual carefully.

Table of Contents

1	Notes on this Manual	4
1.1	Area of validity	4
1.2	Target group	4
1.3	Symbols used in this manual.....	5
1.4	Terms and definitions	6
2	Safety	7
2.1	Intended use	7
2.2	Safety standards.....	7
2.3	Important safety information	7
2.4	Symbols on label	9
2.5	Basic safety protection	9
3	Scope of delivery.....	10
4	Overview	11
4.1	Overview of the product.....	11
4.2	System overview with power management.....	13
4.3	LED Indicators	29
4.4	Interfaces	30
4.5	Special Features.....	31
5	Mounting.....	34
5.1	Planning the Installation	34
5.2	Site Requirements	34
5.3	Selecting the mounting location	36
5.4	Mounting the product.....	36

6 Commissioning and operation.....	52
6.1 Mechanical checks	52
6.2 Electrical checks	53
6.3 Establish a connection to the Ai-charging app	53
6.4 Activate the RFID card	53
6.5 Charging EV	54
6.6 Stop charging	56
7 Cleaning and Maintenance	58
8 Troubleshooting	59
9 Technical data	62
9.1 Inputs and Outputs (AC)	62
9.2 General data	63
9.3 Safety regulations	65
10 Recycling and disposal	66
11 EU declaration of conformity	66
12 Contacts	67

1 Notes on this Manual

General Notes

The Solplanet Smart EV Charger is an AC power charging station, it supplies AC power to charge electric vehicles.



1.1 Area of validity

This manual describes the mounting, installation, commissioning, operation and maintenance of the following SOL APOLLO EV chargers:

- SOL7.4H
- SOL11H
- SOL22H

The series listed above is equipped with a variety of interfaces, please check the technical specifications in section 9 Technical data to confirm the interfaces that are available on the EV charger.

1.2 Target group

This document is intended for qualified persons and end users. Only qualified persons are allowed to perform the activities marked in this document with a warning symbol "  ". The tasks with no "  " symbol may also be performed by end users.

Qualified persons must have the following skills:

- Knowledge of how the EV charger works and is operated;
- Identify the hazards (in terms of a risk assessment), relevant to the working conditions on the site;
- Trained in the installation and commissioning of electrical devices and installations;
- Knowledge of all applicable laws, standards and directives;
- Knowledge of and compliance with this document and all safety information.

1.3 Symbols used in this manual

The safety precautions and general information are used in this manual as follows:



DANGER

DANGER indicates a hazardous situation which, if not avoided, will result in death or serious injury.



WARNING

WARNING indicates a hazardous situation which, if not avoided, can result in death or serious injury.



CAUTION

CAUTION indicates a hazardous situation which, if not avoided, can result in minor or moderate injury.

NOTICE

NOTICE indicates a situation which, if not avoided, can result in property damage.



INFORMATION provides tips which are valuable for the optimal installation and operation of the EV charger.

1.4 Terms and definitions

For the purposes of this document, the terms and definitions given in this document.

Sheet 1

object	Abbreviation	Definition
1	DLB	Dynamic Load Balance
2	EV	Electric vehicle
3	OBC	On-board charger
4	BLE	Bluetooth Low Energy
5	EPS	Emergency Power Supply
6	RFID	Radio Frequency Identification
7	WLAN	Wireless Local Area Networks
8	NFC	Near Field Communication
9	CP	Control pilot, used to monitor and control the interaction between the EV and the EV supply equipment.

2 Safety

2.1 Intended use

The EV charger is an AC charging device.

The EV charger may automatically adjust its output power during operation due to non-ideal conditions e.g., extremely high ambient temperatures.

The EV charger can only be operated in accordance with the information provided in the enclosed documentation and with the locally applicable laws, regulations and standards. Any other application may cause personal injury or property damage.

The EV charger must be used as a stationary device.

All components of the EV charger must remain within their permitted operating ranges at all times.

Adapters, extension cables and conversion cables must not be used with either version of the EV chargers.

2.2 Safety standards

SOL APOLLO EV chargers comply with the EU Low-Voltage Directive 2014/35/EU and the EMC Directive 2014/30/EU. The EV charger also complies with the requirement for safety and EMC in European market. They are labeled with the CE mark.

For more information about certificates in other countries and regions, please visit website (www.solplanet.net).

2.3 Important safety information

Before installing, operating or maintaining this product, it is important to read and ensure that the contents of the following Guide are fully understood. Failure to follow all the specified instructions and procedures, will invalidate the warranty and as such Solplanet will not be liable for any claims for compensation.







 **DANGER****Danger to life due to electric shock when live components or cables are touched !**

- Do not open the EV charger under load or when it is not electrically isolated.
- Do not use the EV charger if it is damaged.
- Do not extend the charging cable with an extension lead.
- Do not touch or insert foreign objects into the EV charger socket or the cable plug.
- Do not install the EV charger near flammable, explosive, or combustible materials.

 **WARNING****Risk of injury due to electric shock !**

- All work on the equipment must only be carried out by qualified personnel who have read and fully understood all safety information and installation requirements contained in this manual.
- The EV charger must be out of reach from children.
- The EV charger must be connected to a protective earth conductor.
- The electrical installation must comply with all applicable local safety requirements, standards and guidelines.
- No modifications, not limited to mechanical or electrical, must be made to the EV charger.
- Components should not be changed or replaced by the end-user or unqualified personnel.
- Do not use conversion adapters or cord extension sets with the EV charger.

2.4 Symbols on label

Symbol	Explanation
	Risk of danger, warning and caution ! Safety information, important for human safety. Failure to observe the safety information in this manual may result in injury or death.
	Be ware of high voltage and operating current. The EV charger operates at high voltage and current. Work on the EV charger must only be carried out by skilled and authorized electricians.
	Certified safety. The product is TUV-tested and complies with the requirements of the EU Equipment and Product Safety Act.
	CE mark. The EV charger complies with the requirements of the applicable CE guidelines.
	Do not dispose of the EV charger with household waste. For more information on disposal, please refer to Section 10 "Recycling and disposal".
	Refer to the manual accompanying the EV charger.

2.5 Basic safety protection

The EV charger provides the following safety protection functions:

- 1) Over-voltage, under-voltage protection;
- 2) Over-frequency, under-frequency protection;
- 3) Over-current protection;
- 4) Residual current monitoring;
- 5) Grounding conductor monitoring;
- 6) Relay fault monitoring;
- 7) Phase lost monitoring;
- 8) Over-temperature monitoring.







3 Scope of delivery

Inspect the product packaging for any external visible damage and ensure that all items in the table below have been included. Contact your supplier if the accessories delivered are incomplete or if the EV charger or accessories show signs of damage.

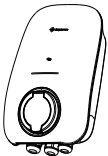
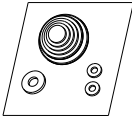
Sheet 2

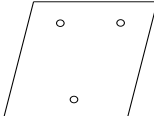
Object	Description	Quantity
A	EV charger	1 piece
B	Rubber seal kit	1 set
C	Screw accessory kit: Wall anchors and hexagon bolts (×3) M4×10mm screw (×2) M4×6mm screw (×1) ST3×10mm screw (×2)	1 set
D	Mounting template	1 piece
E	RFID card	3 pieces
F	AC Input cable fastener	1 piece
G	Energy meter (Optional)	1 piece
H	Cable holder (for cable version)	1 piece
I	Quick installation guide	1 piece

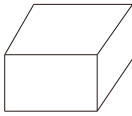
Sheet 3

				
A	B	C	D	
				
E	F	G	H	I

4 Overview

4.1 Overview of the product

Socket Version

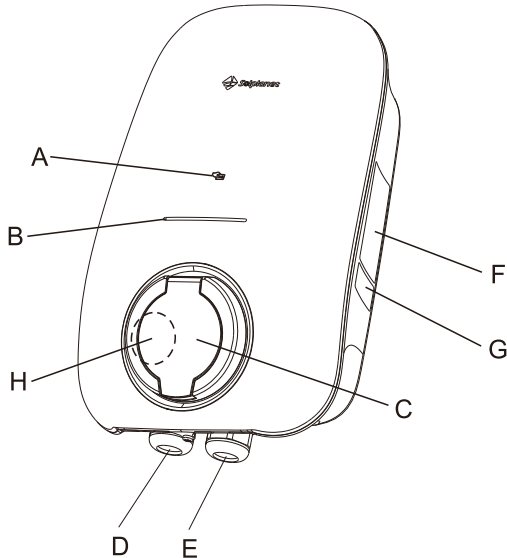

Figure 1: Overview of the socket version

Sheet 4

Position	Description
A	RFID / NFC Reader Area for RFID card scanning or for use with NFC authorized smart devices.
B	LED strip Indicates the operating state of the EV charger.
C	Socket
D	Input cable gland
E	Communication cable gland
F	Type label
G	QR code
H	Knockout entry reserved for input AC cable.

Cable Version

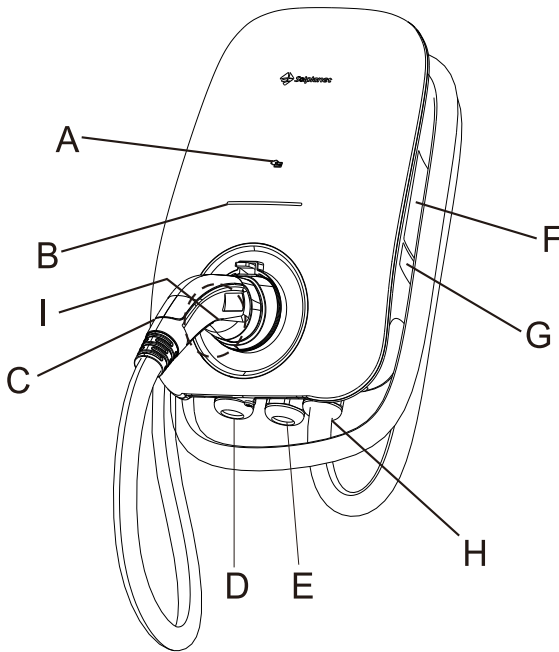

Figure 2: Overview of the cable version

Sheet 5

Position	Description
A	RFID / NFC Reader Area for RFID card scanning or for use with NFC authorized smart devices.
B	LED strip Indicates the operating state of the EV charger.
C	Charging plug
D	Input cable gland
E	Communication cable gland
F	Type label
G	QR code
H	Charging plug cable
I	Knockout entry reserved for input AC cable.

4.2 System overview with power management



The product provide disconnection means and a residual current monitoring for detecting 6 mA direct residual current. In order to guarantee safety in accordance with IEC 61851-1 that RCD Type A and appropriate equipment that ensures the disconnection of the supply in case of DC fault current above 6 mA. The additional overcurrent protection and approved RCD Type A need to be provided in the installation as well.

The SOL APOLLO EV charger provides the Dynamic Load Balance function for users when installed together with an energy meter. This function automatically adjusts the charging power depending on the power flow within the system. When the homes power consumption is stable and the PV power increases, the EV charger charging power will increase accordingly. The increase of power will be no greater than 32A and can be also limited by the EV on-board charger (OBC).

And the system overview in different application are like the pictures below:

a) System Overview with EV-Charger Only

✓ EV Charger DLB

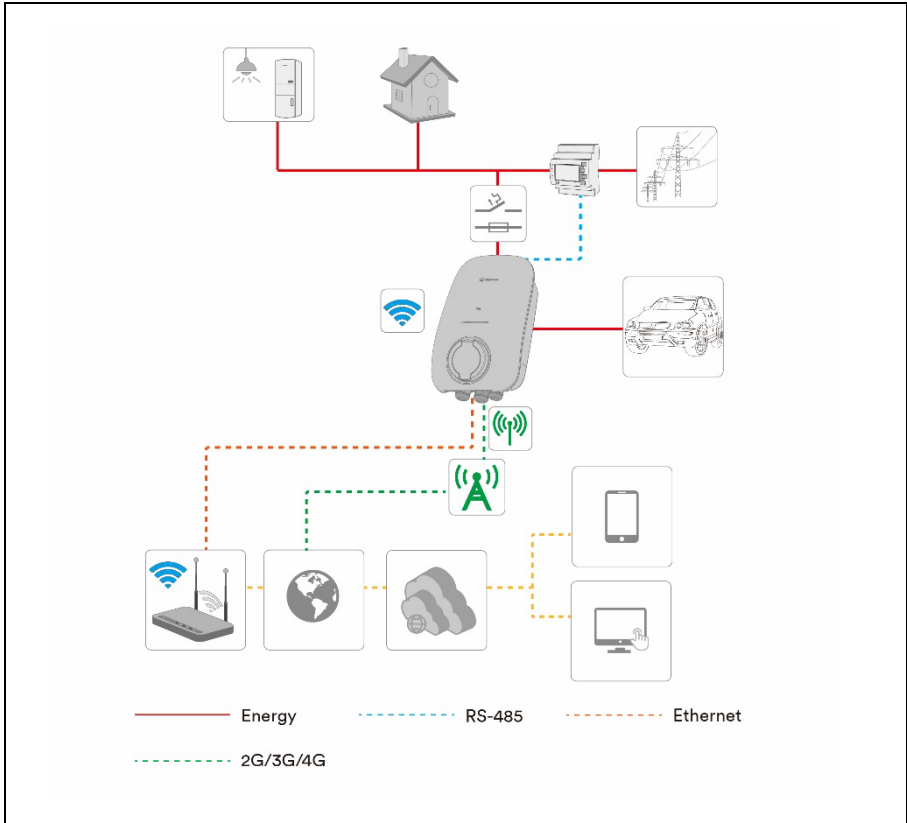

Figure 3

EV Charger DLB

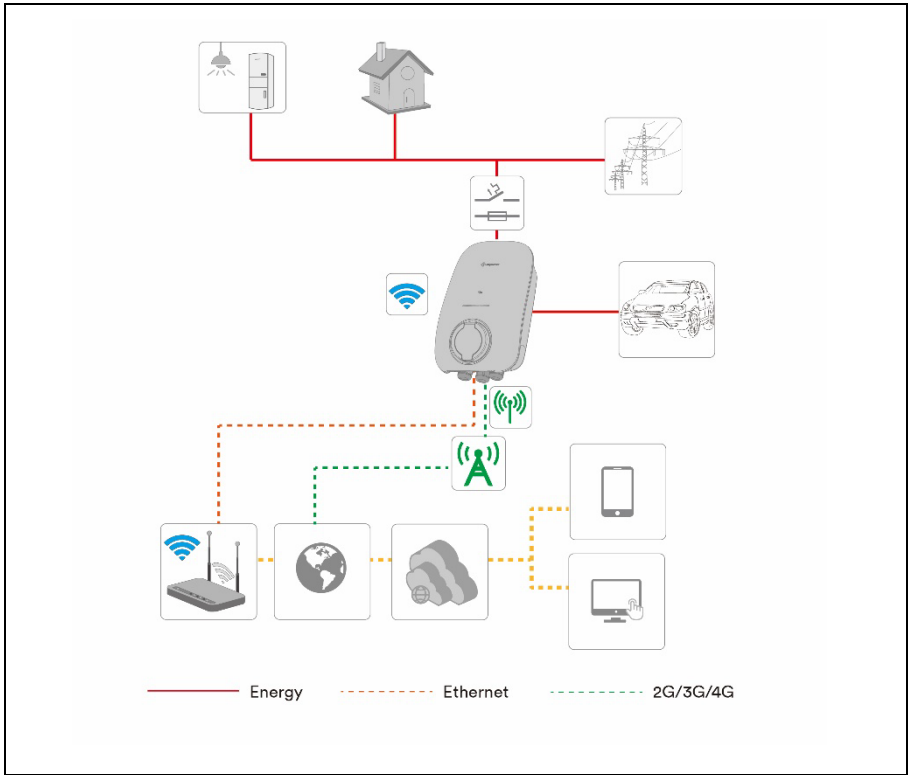

Figure 4

b) System Overview with EV-Charger and Ongrid Inverter

✓ EV Charger DLB ✗ Ongrid inverter 0-export

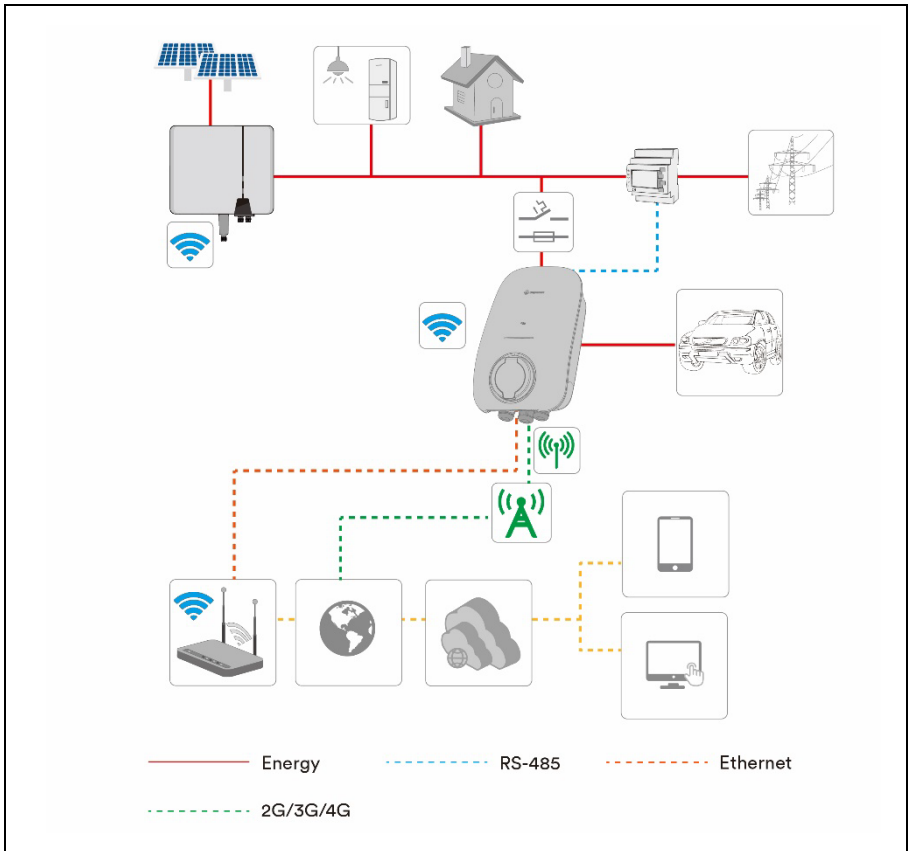

Figure 5

✓ EV Charger DLB ✓ Ongrid inverter 0-export

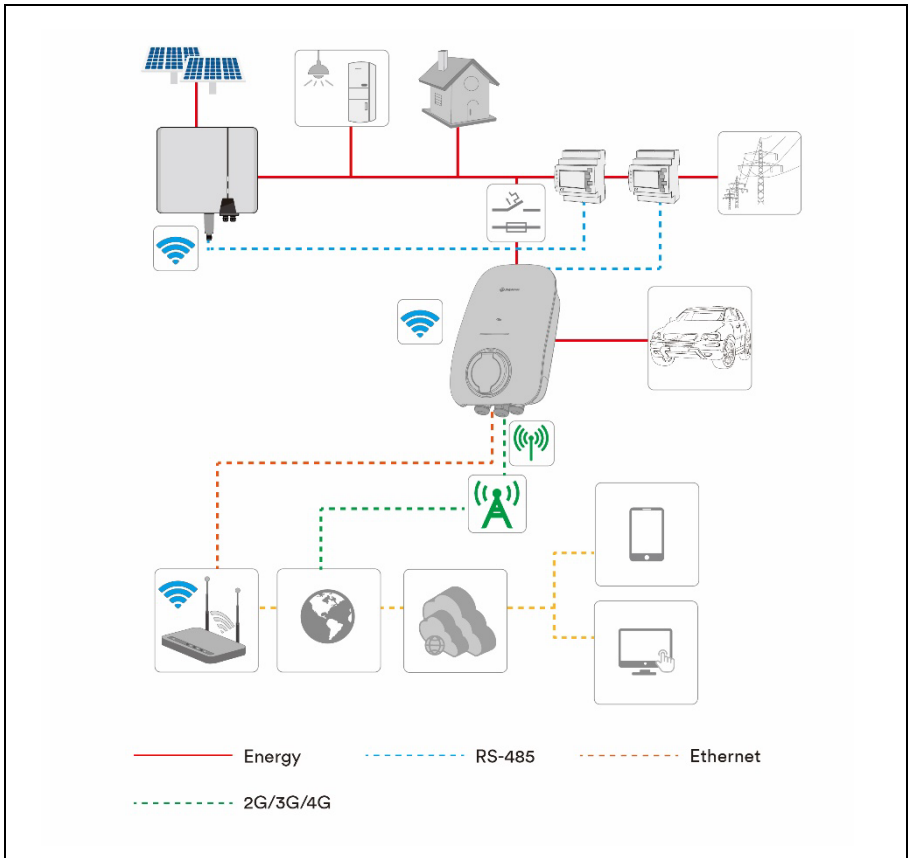

Figure 6

❌ EV Charger DLB ❌ Ongrid inverter 0-export

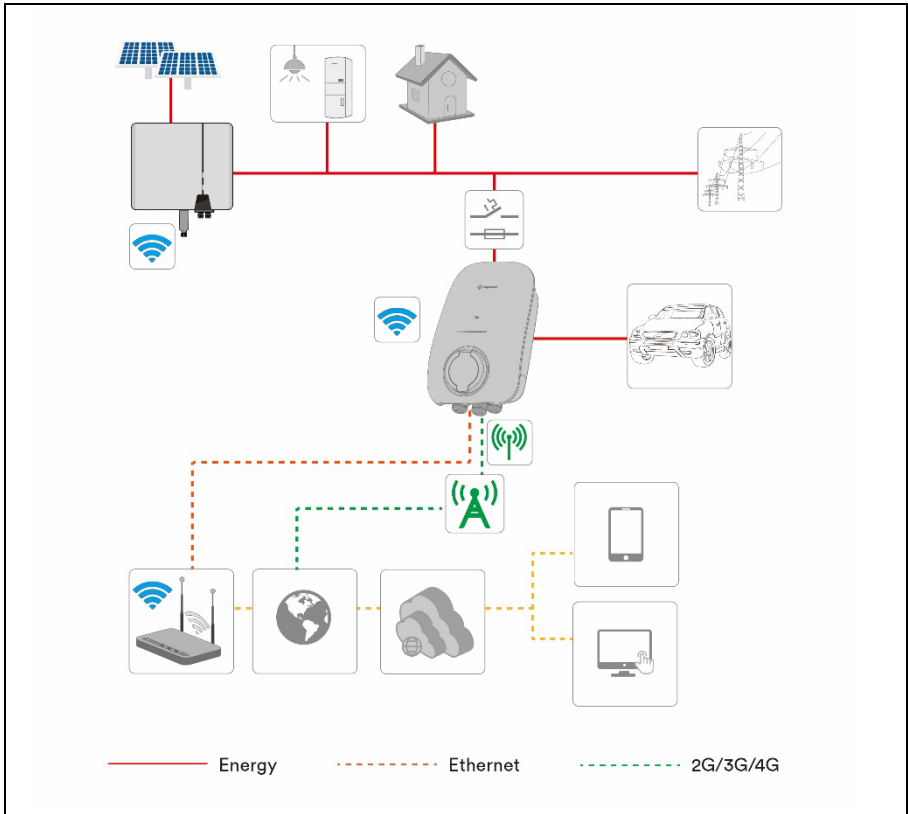

Figure 7

c) System Overview with EV-Charger and Hybrid Inverter

- ❌ EV Charger DLB
- ✅ Hybrid inverter 0-export

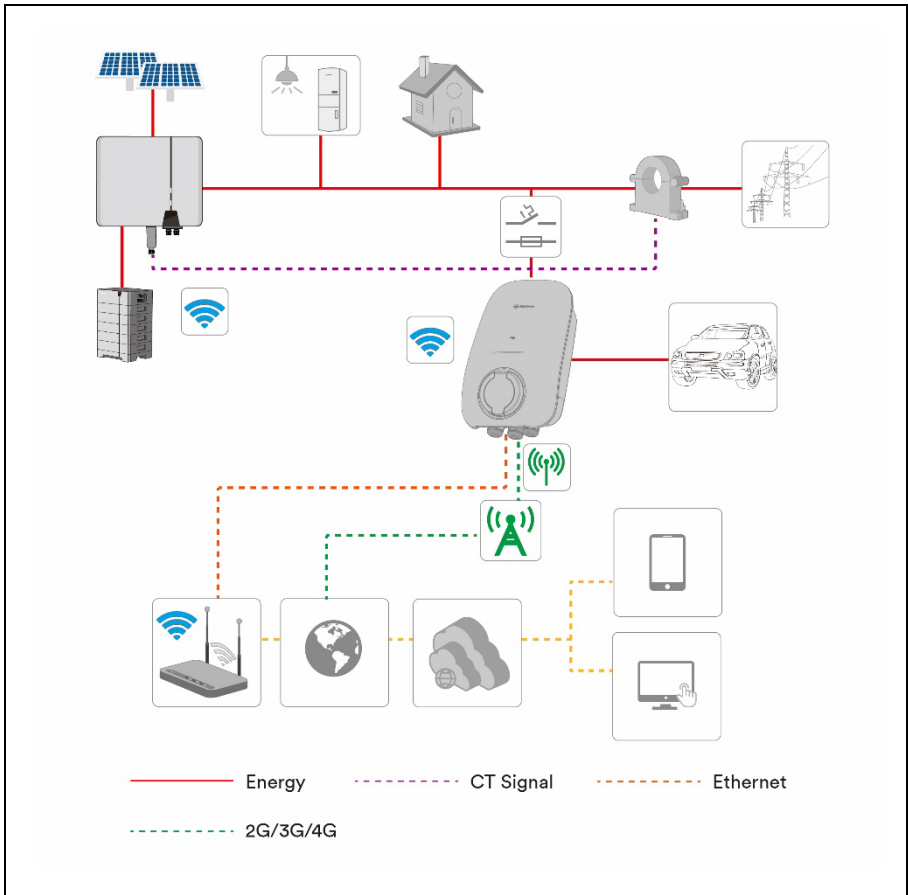

Figure 8

✓ EV Charger DLB ✓ Hybrid inverter 0-export

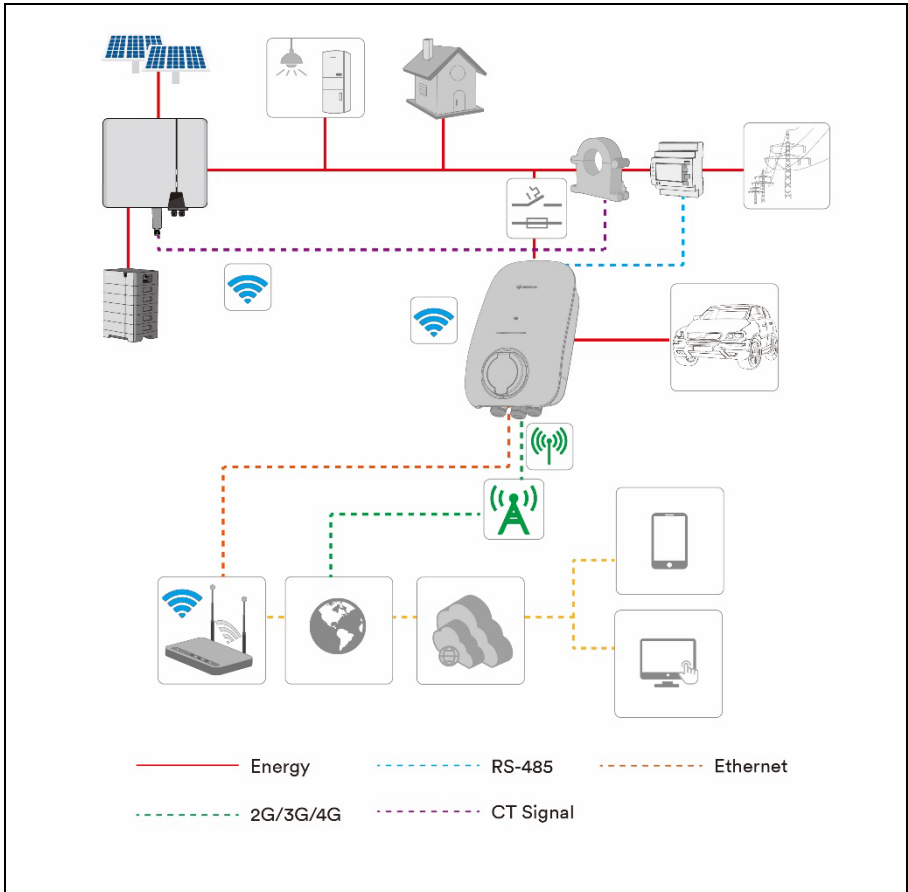

Figure 9

d) System Overview with EV-Charger, Hybrid and Ongrid Inverter

✓ EV Charger DLB ✓ Hybrid inverter 0-export

✗ Ongrid inverter 0-export

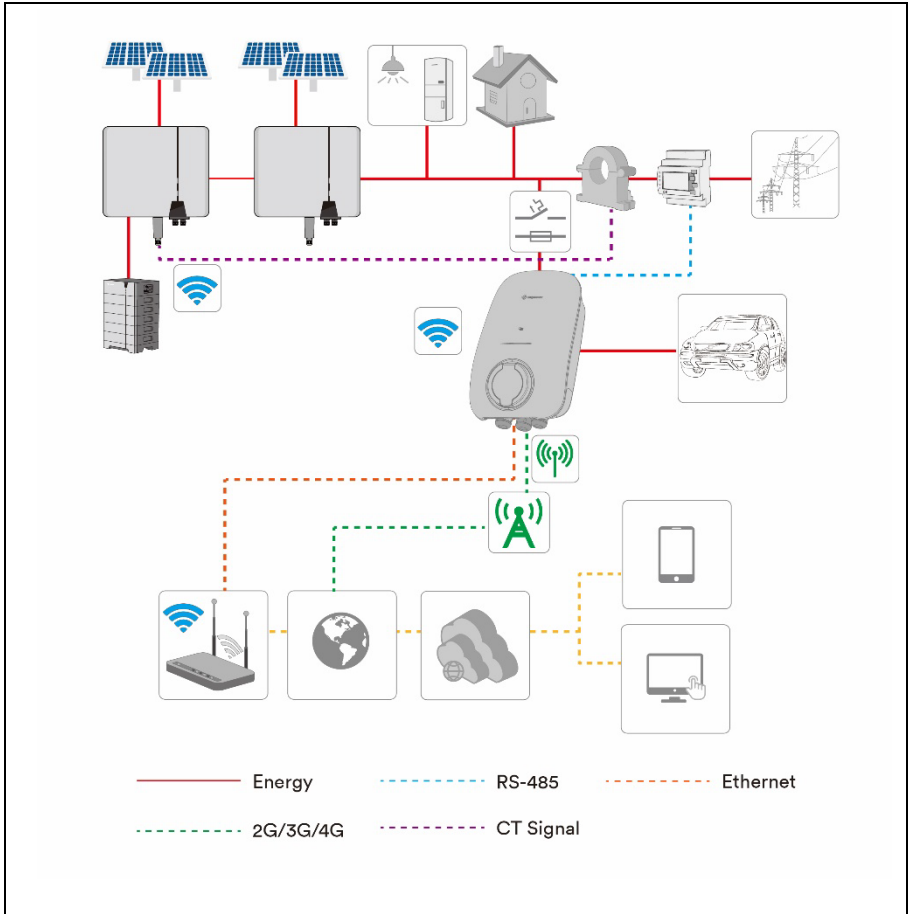

Figure 10

✓ EV Charger DLB ✓ Hybrid inverter 0-export

✓ Ongrid inverter 0-export

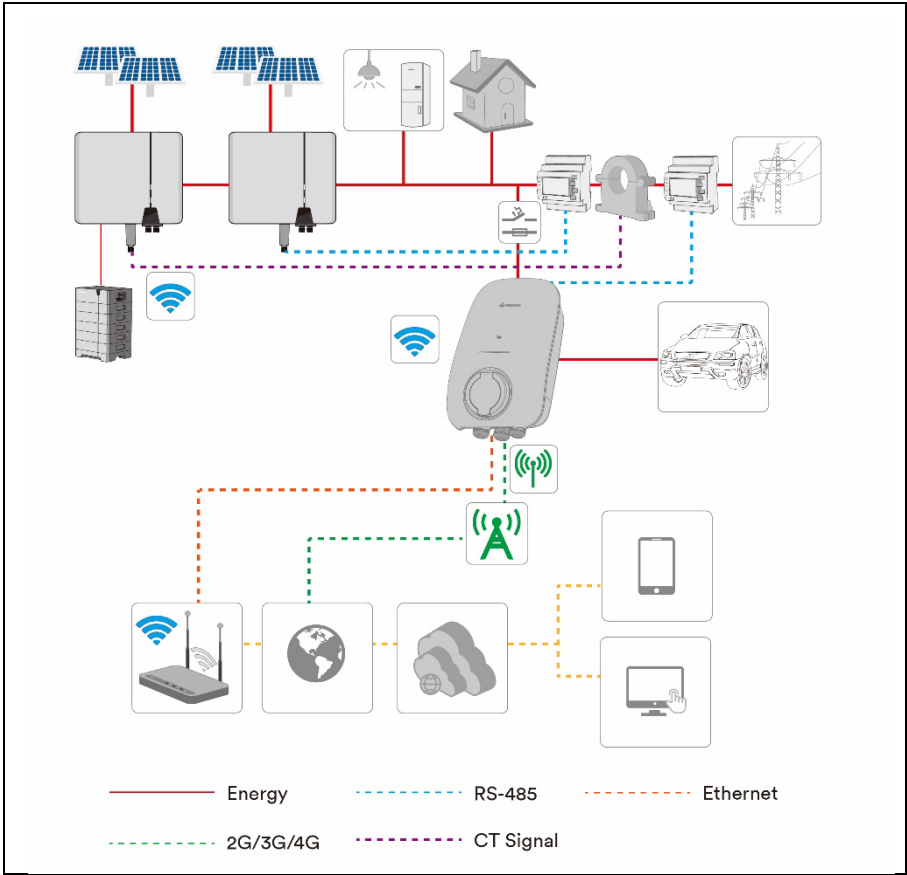

Figure 11

❌ EV Charger DLB ✅ Hybrid inverter 0-export

❌ Ongrid inverter 0-export

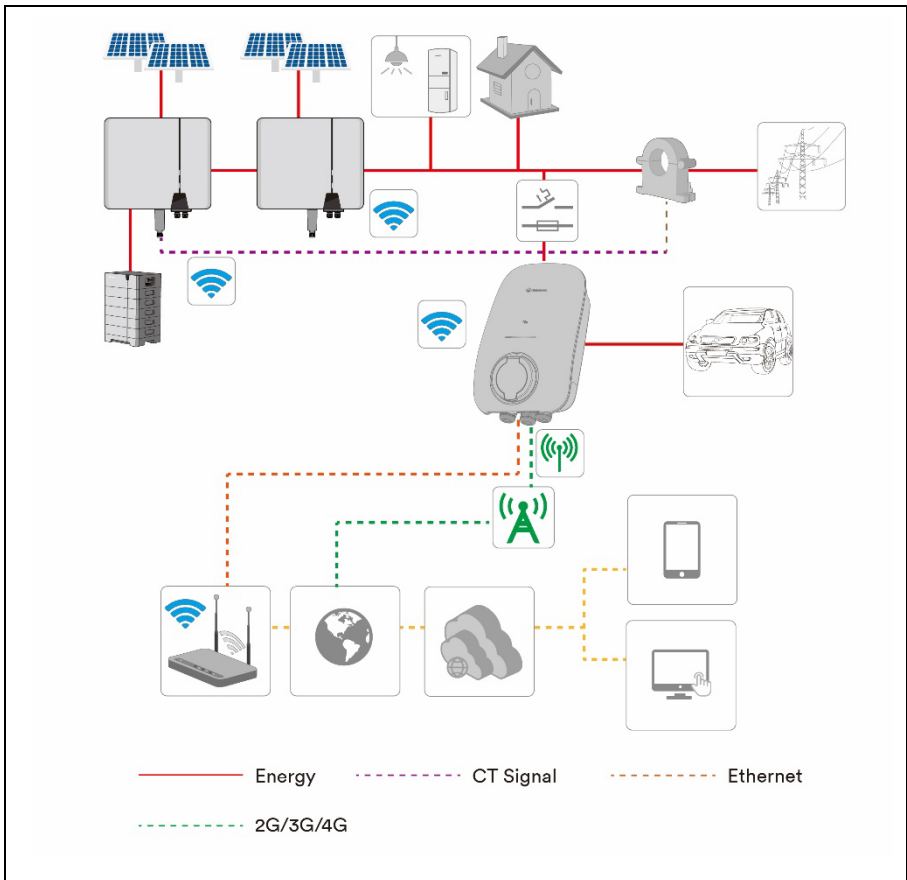

Figure 12

If you choose our Hybrid Inverter ASW H-T2 series、 ASW H-T3 series, then the system overview will be changed as below:

e) System Overview with EV-Charger and Hybrid Inverter

- ✔ EV Charger DLB
- ✔ Hybrid inverter 0-export

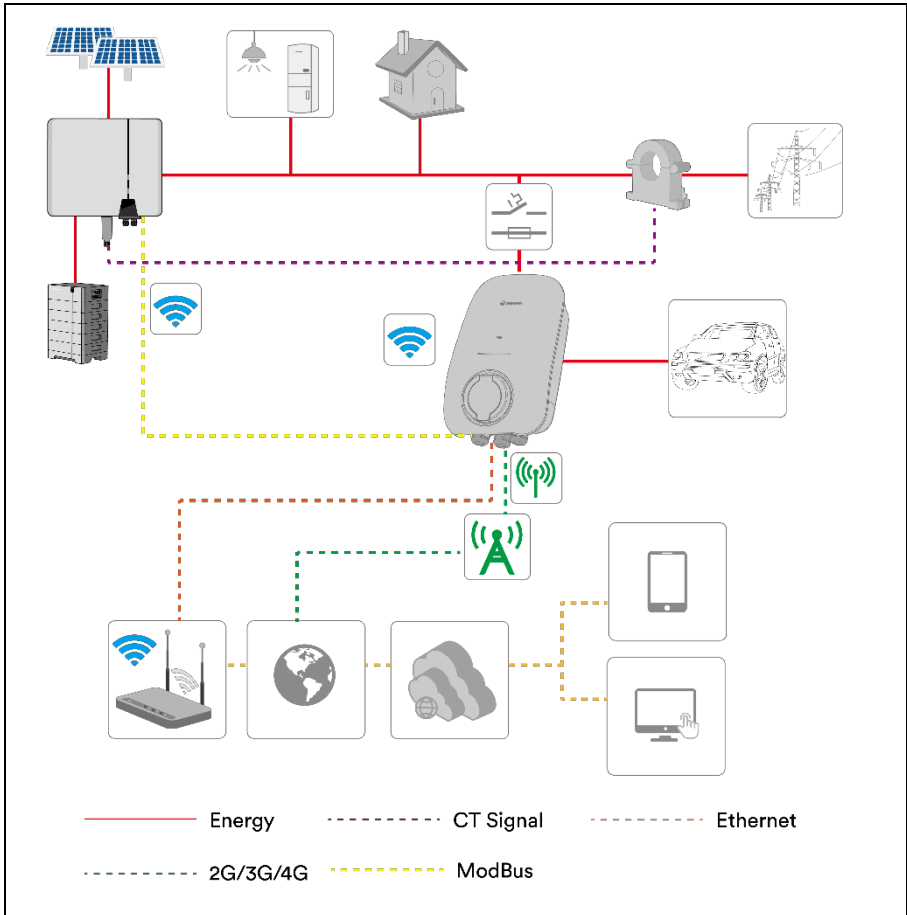

Figure 13

f) System Overview with EV-Charger, Hybrid and Ongrid Inverter

✓ EV Charger DLB ✓ Hybrid inverter 0-export

✗ Ongrid inverter 0-export

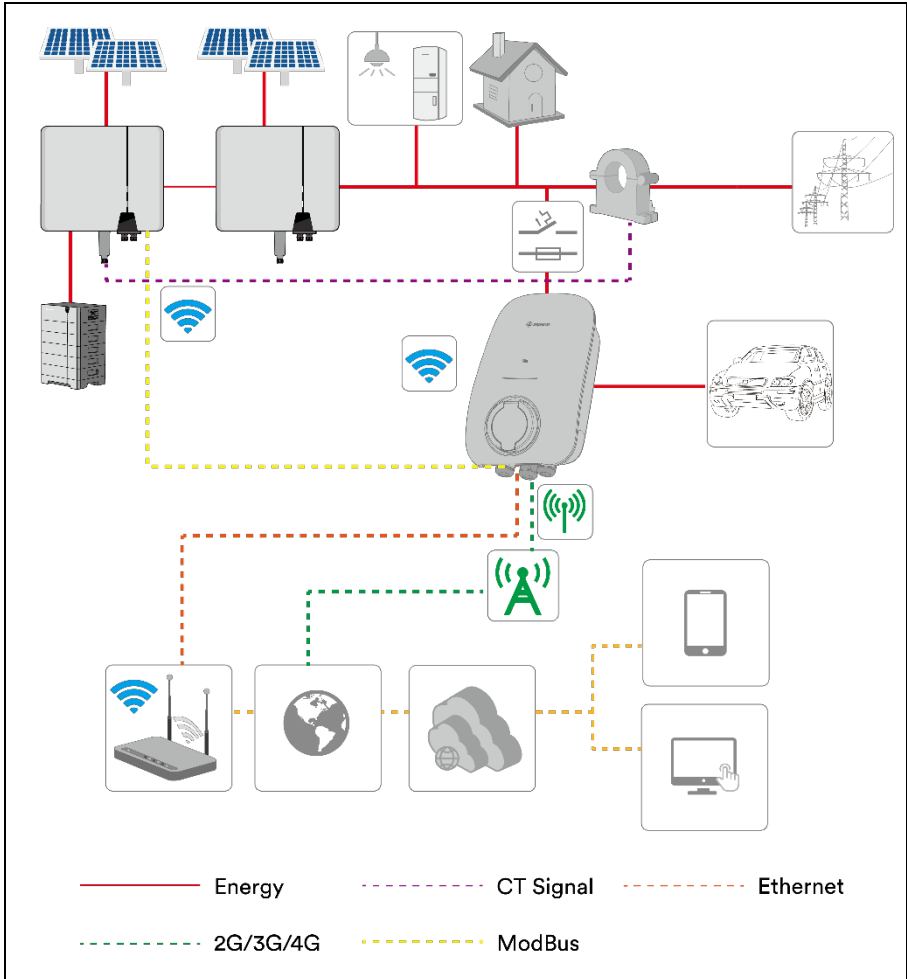

Figure 14

✓ EV Charger DLB ✓ Hybrid inverter 0-export

✓ Ongrid inverter 0-export

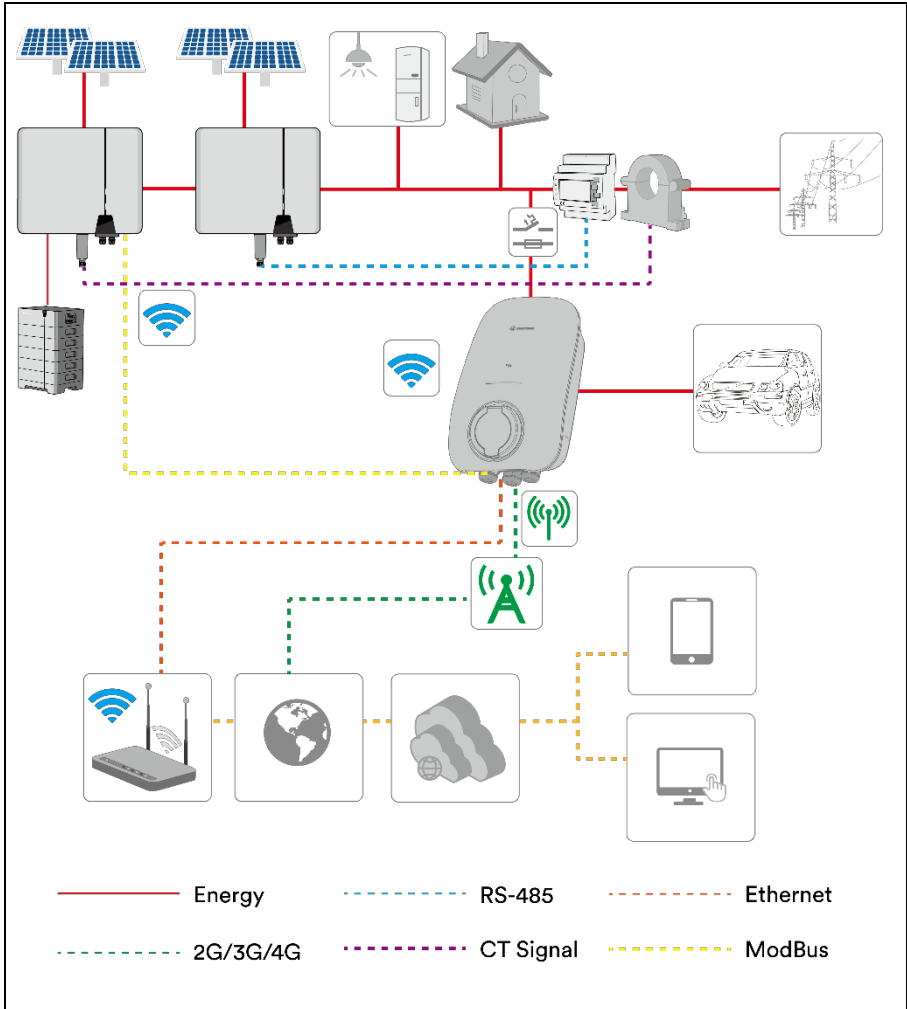



















Figure 15

Item	Description	Remark
	<p>PV String</p>	<p>The product supports to connect the monocry-stalline silicon, polycrystalline silicon and thin-film without grounding.</p>
	<p>Hybrid inverter</p>	<p>ASW H-T2 and ASW H-T3 series products have a EPS port. ASW H-T2-O and ASW H-T3-O series products doesn't have a back-up port.</p>
	<p>Smart meter</p>	<p>The smart meter is the central device responsible for energy management. The smart meter also can be replaced by three current transformer which can communication with inverter directly.</p>
	<p>Utility grid</p>	<p>The product can connect to TN and TT ground-ing system grid.</p>
	<p>Battery system</p>	<p>The product must only be operated in connection with an intrinsically safe lithium-ion battery sys-tem</p>

		approved by AISWEI.
	Ai-Dongle	The Ai-Dongle supports Ethernet communication and WLAN communication. It is not recommended to use both communication methods at the same time.
	Back-up load	The back-up load directly connected to the EPS port of the inverter. The back-up load can be power supplied by the inverter after the utility grid is failure.
	Normally load	The normally load directly connected to utility grid. The normally load will be power off after the utility grid is failure.
	Router	The product can connect to router through Wi-Fi signal or Ethernet cable.
	Internet	The monitor information can transfer to Cloud Server through Internet.

	Cloud server	The monitor information is stored at cloud server.
	Smart phone	The APP can be installed on the smart phone and then review the monitor information.
	Computer	The monitor information also can be review on the computer.
	Ai-charger	APOLLO EV Charger.
	CT	Current transformer.
	Cellsite	Communication base station.
	Protective device	Protective device with RCD and LSS.

4.3 LED Indicators

The EV charger is equipped with one LED strip which provides information about the various operating states represented by four colours.

Explanation of the different light signals:

Sheet 7

LEDs Status	EV Charger Status
Green - solid	Standby

Ice blue - solid	- Connected to vehicle and ready to charge - End of charging - Charging paused
Blue - pulsing	Charging
Green - pulsing	Charging (with full green power)
Ice blue - pulsing	Charging (mix of grid/green power)
Yellow-solid	E-LOCK
Red - blinking	Fault
Purple - blinking	Firmware update
Ice blue - blinking (once)	RFID card identification succeeded (with operation)
Ice blue - blinking (twice)	RFID card binding succeeded
Purple - blinking (once)	RFID card identification succeeded (without operation)
Purple - blinking (twice)	Invalid RFID card
Purple - blinking (three times)	Binding RFID cards over limit

4.4 Interfaces

The SOL APOLLO EV charger is equipped with the following interfaces and functions:

WLAN

The EV charger is supplied with WLAN interface as standard.

BLE

The EV charger is supplied with a BLE (identifiable by the EV charger serial number) interface as standard. The BLE connection facilitates a point-to-point connection between the EV charger and a smart mobile device.

Ethernet (optional)

The EV charger is supplied with Solplanet Speedwire as optional configura-

tion, which is a type of communication based on the Ethernet standard. Solplanet Speedwire is designed for a data transfer rate of 100 Mbps and enables optimum communication between the EV charger and the Ai-charging app via a router.

NFC Authorization

This function activates the EV charger by detecting the digital key stored in a smart phone or smart device. Check whether the smart phone is compatible with NFC and NFC function which is required to be activated. Follow your smart phone's NFC instructions and place the authorized RFID card on the phone's NFC area, and copy the card data onto your smart phone.



Please note that this function does not support iPhone or other apple products due to Apple's restrictions for NFC.

4.5 Special Features

Dynamic Load Balancing (requires an energy meter)

Dynamic load balancing ensures you never overdraw your property's power capacity by balancing the power consumption between your EV charger and other electrical household appliances. The system measures the power consumption of the house by the energy meter (or assorted hybrid inverter with meter) and allocates all available power to your EV. The charge power is continuously adjusted, in response to changes in generation or power consumption elsewhere around the house. You can maintain a safe and convenient charging at all times while keeping costs low. The EV charger may prioritise the use of excess solar power generated by a PV system, if available, rather than the grid power.

Solar PV Mode (requires an energy meter)

Selecting this mode, the charger will consume 100% solar energy to charge your car, it will not use grid power for charging. Same as dynamic load balancing, the system measures the power consumption of the house by the energy meter (or assorted hybrid inverter with meter) and allocates all available power to your EV. The charge power is continuously adjusted, in response to changes in generation or power consumption elsewhere around the house. This mode requires a minimum 4.2kW (suppose power supply L-L voltage is 398Vac) of solar export power available, if lower than this value, charging process will stop, and it will restore the output automatically when higher than this value.

Eco Mode (requires an energy meter)

Eco Mode means maximum use of excess solar power and minimize the use of grid power in this mode. Unused surplus solar power will be detected and mixed with grid power to charge your car.

Boost Eco Mode (requires an energy meter)

Boost Eco Mode is one of the special type of Eco Mode. It also means maximum use of excess solar power but with a given limit of grid power, Boost Eco Mode may output lower power for the charger than Eco Mode due to this reason. Unused surplus solar power will be detected and mixed with limited grid power to charge your car.

Dry Contact Signal Detection

This feature is designed for compliance with German §14a statute. The output power of the charger will be limited at 4.2kW when receiving the signal from the grid management system and maximum output power will restore when the signal disappear.

OCPP

OCPP is short for Open Charge Point Protocol, it is a programme which is used for unified communication between charging station and charging station monitor system. This protocol supports central management system of charging service provider interconnecting with all ev chargers, mainly used to solve the problems caused by private charging network communication.

Please make sure the EV charger is configured at network connection mode before enable OCPP function.

5 Mounting

5.1 Planning the Installation

Qualified Person

Installing and connecting the product must be done by a qualified electrician. Laws and regulations, relevant to the country of installation, regarding the safety of persons, animals, and property must be observed. A typical planning procedure may include but are not limited to the following:

1. Calculate the existing electrical load to determine the maximum operating current.
2. Calculate the appropriate cable size with respect to distance to minimize voltage drops.
3. Obtain any necessary permits from the local authority that has jurisdiction and confirm that the follow-up inspection has been scheduled by a qualified electrician after the installation is complete.
4. Use only copper conductors.
5. Use conductors that are sized in accordance with local wiring regulations. The selected cable gauge must be able to sustain periods of a constant load up to 16A / 32A.
6. Each unit should be connected to an appropriately sized circuit breaker.
7. Knowledge of the current capacity of the site (in amperes).

5.2 Site Requirements

1. Ensure the product is installed out of reach from children.
2. Ensure appropriate access to the product for installation and maintenance.
3. Ensure there is adequate heat dissipation by observing the minimum clearance to walls, other EV chargers or objects:

Direction	Min. Clearance (mm)
above	200
below	200
sides	200

- The installation height from the ground is between 1400mm and 1600mm.

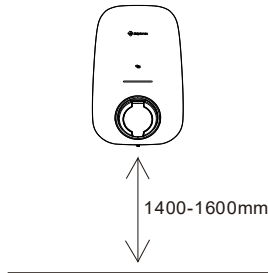

- The ambient temperature below 40°C is recommended (to ensure optimal operation).
- It is recommended to mount the product under a shaded site of the building or to mount a sun shield above the product.
- Avoid exposing the product to direct sunlight, rain and snow to ensure optimal operation and an extended service life.

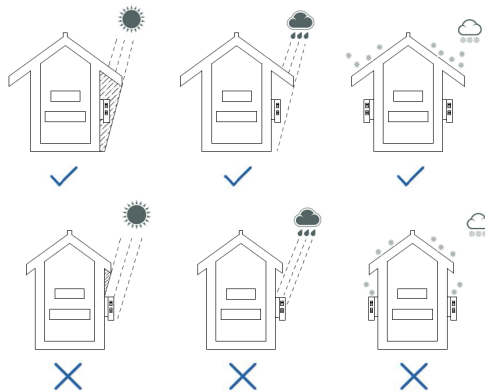

- The mounting method, location and surface must be suitable for the products weight and dimensions.
- If mounted in a residential area, we recommend mounting the product on a solid surface. Plasterboard and similar materials are not recommended.
- Do not place any objects on the product.

5.3 Selecting the mounting location



DANGER

Danger to life due to fire or explosion

- Despite careful construction, if installed incorrectly or mounted in unsuitable locations, electrical devices can cause fires which may result in death or serious injury.
- Do not mount the product on flammable construction materials.
- Do not mount the product in areas where flammable materials are stored.
- Do not mount the product in areas where there is a risk of explosion.

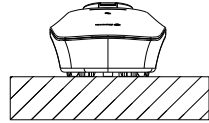
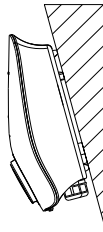
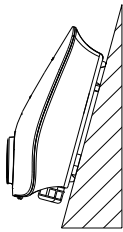
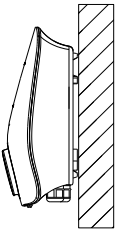

1. Mount the product vertically or tilted backward by a maximum of 15°.
2. Never mount the product tilted forward or sideways.
3. Never mount the product horizontally.
4. Mount the product at eye level to make it easy to operate and to read the LED strip.
5. The electrical connection area must point downwards.

5.4 Mounting the product

Removing the decorative cover

1. Remove the bottom screw (A) on the flat workbench.
2. It is recommended to start at the bottom of enclosure (C) when removing the decorative cover (B).

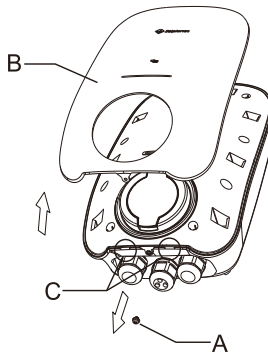

Figure 16

Drill three $\varnothing 10\text{mm}$ holes at a depth of approximately 70mm for the mounting screws

1. Hold the mounting template (A) against the wall and ensure that the installation is level by using the spirit level.
2. Mark the location for three mounting holes (B).
3. Drill three mounting holes (B).
4. Insert the wall plugs (C) into the mounting holes (B).

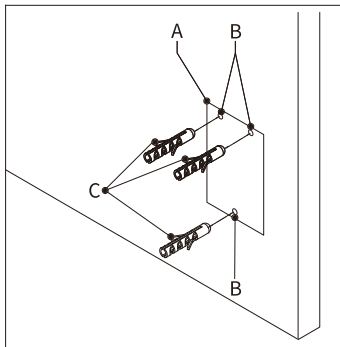

Figure 17

Inserting the upper mounting screws

1. Install the upper mounting screws (A) in the upper holes (B).
The recommended torque is 4.4Nm.
2. Ensure the screw protrudes at a length (X) out from the wall.
The length of (X) is recommended to be 3mm (0.12inch).

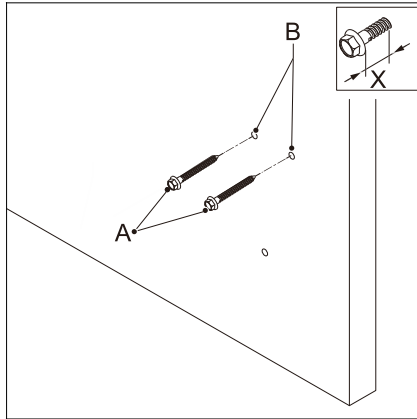

Figure 18

Installing the EV charger on the wall

1. Align the openings (A) over the upper mounting screws (B).
The upper mounting screws support the EV charger.

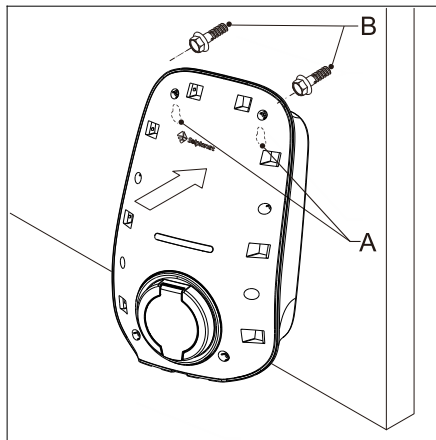

Figure 19

Removing the top cover

1. Remove the eight screws (A) located on the top cover (B).
2. Remove the top cover (B) (Take care of the cable wires that connect to the top cover for the socket version).

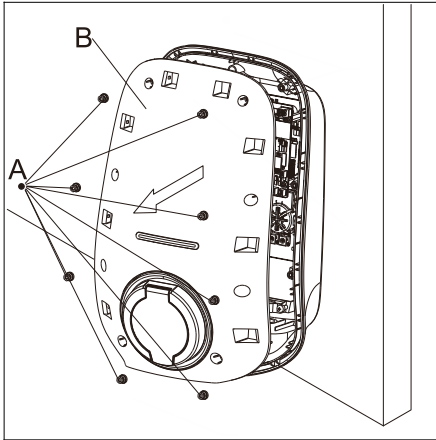

Figure 20

Installing the inner screw on the bottom cover

1. Thread the screw (A) through the sealing rubber (B). Then install the mounting screw (A) to secure the enclosure to the surface. The recommended torque is 4.4Nm.

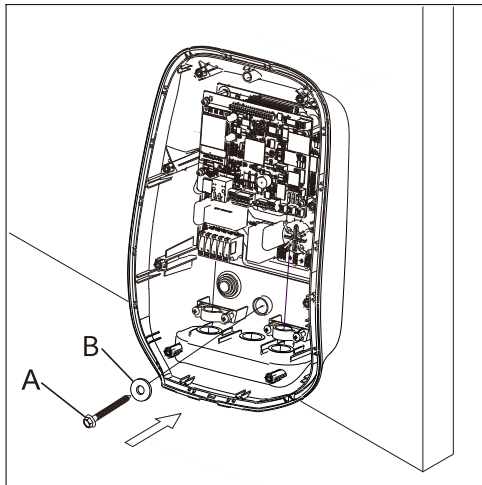

Figure 21

Install the incoming AC supply cable



- All electrical installations must be done in accordance with all local and national rules.
- Ensure that all power sources have been electrically isolated before any electrical terminations have been made.

There are two options for installing the incoming AC supply cable.

Option 1:

Through the cable gland (A) located on the bottom of the enclosure.

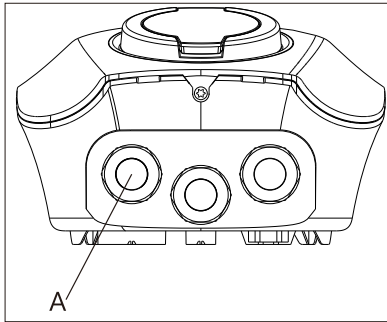

Figure 22

Option 2:

Drilling a hole through the rubber seal located on the rear of the enclosure (A).

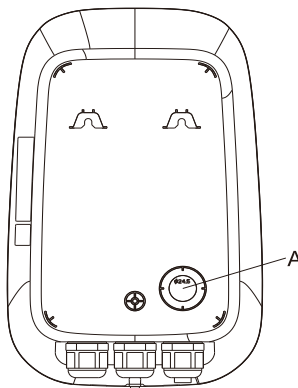
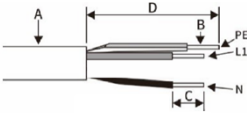

Figure 23

- Strip the incoming AC supply cable as shown below, and crimp the copper wire to the appropriate OT terminal (according to DIN 46228-4, provided by the customer).

Sheet 8

Single phase



Object	Description	Value
A	External diameter	18-21mm
B	Copper conductor cross-sectional area	4-16mm ²
C	Stripping length of the insulated conductors	12mm
D	Stripping length of the cable outer sheath	75mm
Note: the PE conductor is at least 5mm longer than the L and N conductors.		

Three phase

Sheet 9

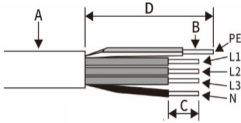

Object	Description	Value
A	External diameter	18-21mm
B	Copper conductor cross-sectional area	4-16mm ²
C	Stripping length of the insulated conductors	12mm
D	Stripping length of the cable outer sheath	75mm
Note: the PE conductor is at least 5mm longer than the L and N conductors.		



Recommend that use the cable whose copper conductor cross-sectional area $\geq 6\text{mm}^2$ for rated current 32A (SOL7.4H and SOL 22H) , and the cable length should not be over 50 meter; recommend that use the cable whose copper conductor cross-sectional area $\geq 4\text{mm}^2$ for rated current 16A (SOL 11H), and the cable length should not be over 70 meter.

2. Install the incoming AC supply cable

Option 1

Remove the cable gland from the bottom of the enclosure.

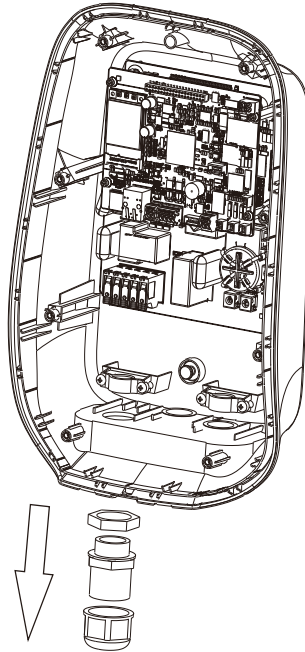

Figure 24

Thread the incoming AC supply cable through the cable gland, loosen the nut (A).

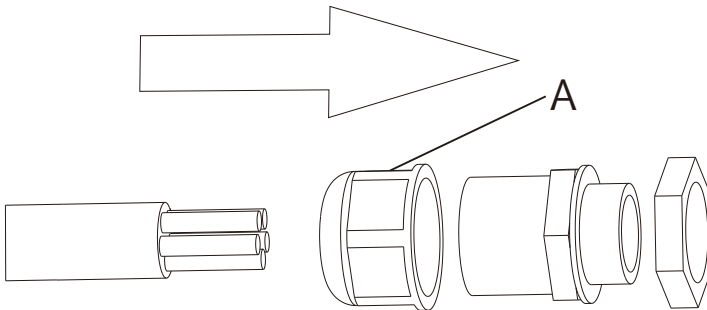

Figure 25

Install the cable gland on the bottom of the enclosure, fasten the nut (B) and then fasten the nut (A).

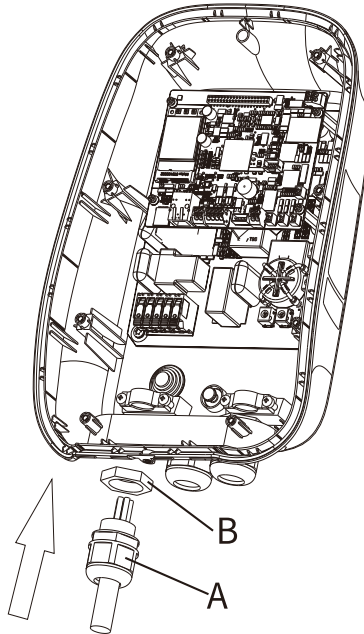

Figure 26

Option 2:

According to the diameter of the incoming AC supply cable, select the appropriate circle on the rubber seal to penetrate.

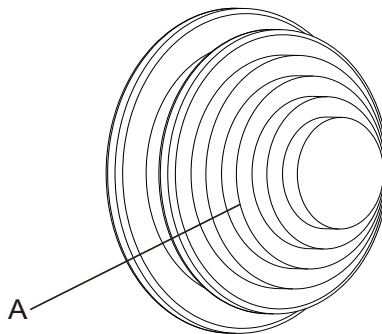

Figure 27

Thread the input cable through the rubber.

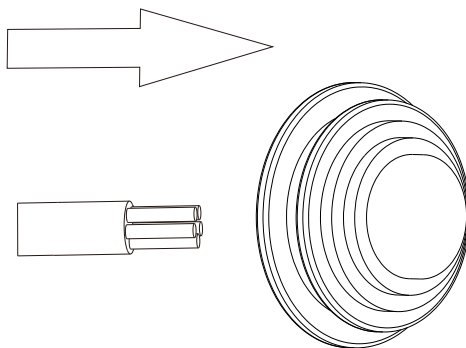

Figure 28

Install the rubber seal (A) on the rear of the enclosure (B).

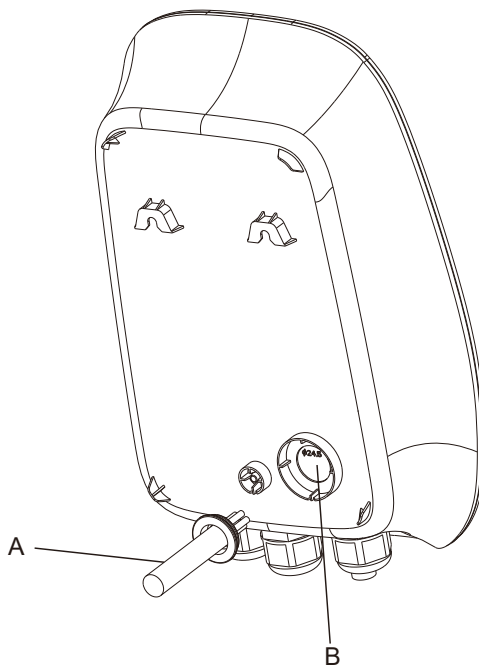

Figure 29

- Secure the cables (A) with the cable clip (B). Install the two screws (C) to secure the cable. (For Option 1)

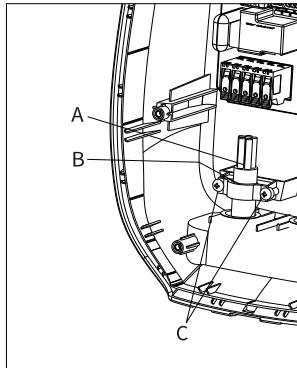

Figure 30

- Terminate the incoming AC supply cable.

Single phase

Loosen the cable clamps (A) of the terminal block.

Insert the cables into terminal block (B).

Connect the below wires:

- Line (C)
- Neutral (D)
- Grounding (E)

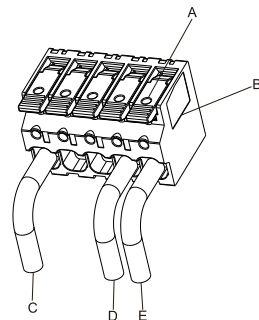

Figure 31

Three phase

Loosen the cable clamps (A) of the terminal block.

Insert cable into the terminal block (B).

Connect the below wires:

- Line L1 (C)
- Line L2 (F)
- Line L3 (G)
- Neutral (D)
- Grounding (E)

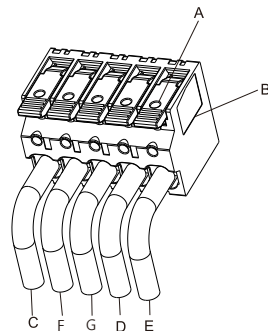

Figure 32

Installing the Ethernet (RJ-45) (optional Ethernet)

To connect the EV charger to a router, ensure an ethernet cable is connected to the ethernet (RJ-45) port of the EV charger and to an RJ-45 port of the router. The pin assignment is as the table below.

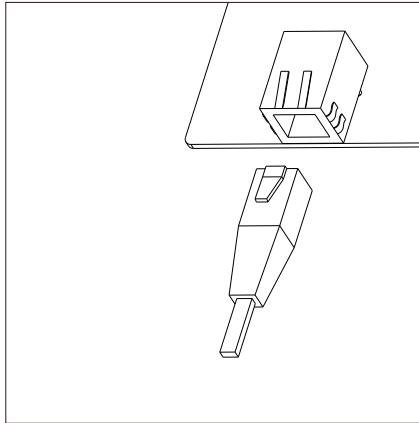

Figure 33

Sheet 10

Pin	Name	Description
1	TX+	Tranceive data+
2	TX-	Tranceive data-
3	RX+	Receive data+
4	N/C	Not connected
5	N/C	Not connected
6	RX-	Receive data-
7	N/C	Not connected
8	N/C	Not connected

RS-485 communication cable for energy meter

For RS-485 communication a standard ethernet cable is recommended. The pin assignments are shown below. Strip the wire as shown in the figure 31, and crimp the copper wire to the appropriate OT terminal (according to DIN 46228-4, provided by the customer) if the cable is multi strand flexible conductor. The other end of the cable should be connected to the

corresponding terminals of the energy meter, please refer to the energy meter manual for further information.

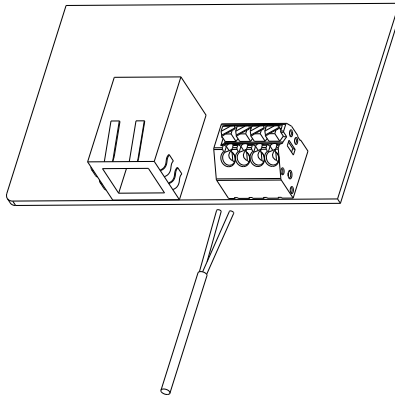

Figure 34

Sheet 11

Pin	Name	Description
1	RS-485A-1	For communication with an energy meter
2	RS-485B-1	
3	RS-485A-2	For communication with an energy meter
4	RS-485B-2	

Dry contact signal wire for §14a EnWG (optional)

Strip the wire as shown in the figure 32, and crimp the copper wire to the appropriate OT terminal (according to DIN 46228-4, provided by the customer) if the cable is multi strand flexible conductor. The other end of the cable should be connected to the control device of the grid (no need to distinguish between positive and negative).

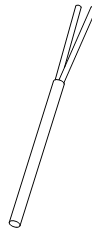

Figure 35

The specific operation steps for installing Ethernet & RS485 & dry contact signal cable as below:

1. Remove the middle cable gland (A) at the bottom of the enclosure.

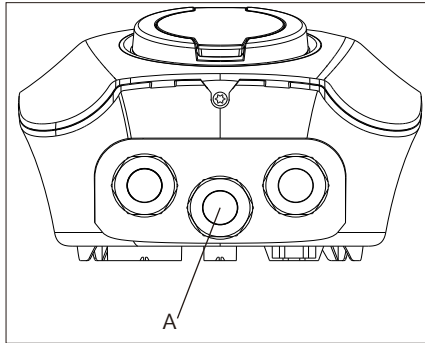

Figure 36

2. Remove the external nut (A), then remove the rubber plug (B). Next, insert the ethernet cable into the hole (C). Repeat the similar step for the RS-485 cable & dry contact signal cable installation.

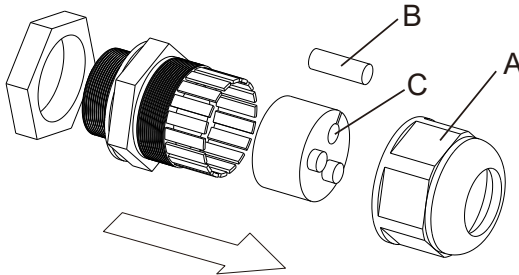

Figure 37

3. Assemble the cable gland and loosen the external nut (A).

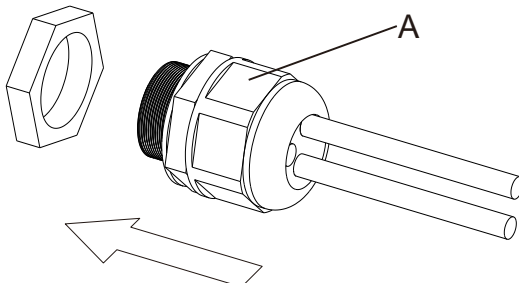

Figure 38

4. Install the cable gland at the bottom of the enclosure and fasten the nut (B), afterwards fasten the nut (A).

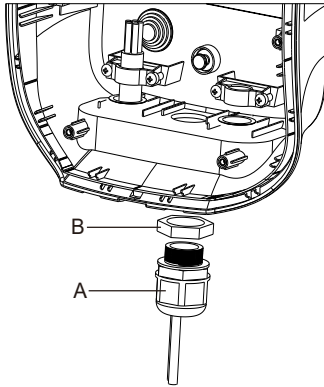

Figure 39

5. Insert the RJ-45 plug of the ethernet cable in the RJ-45 socket (A). Connect the RS-485 cable to the RS-485 connector (B). Connect the dry contact signal cable to the dry contact connector (C).

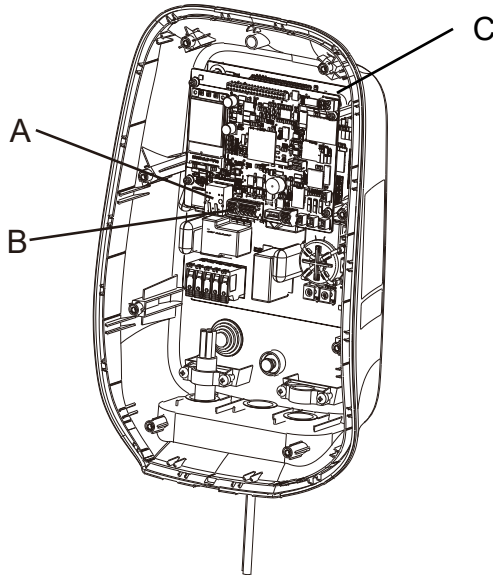

Figure 40

Access to parts

Removing the decorative cover

Removing the following parts:

Screws (A)

It is recommended to start at the bottom of the enclosure (C) when removing the decorative cover (B).

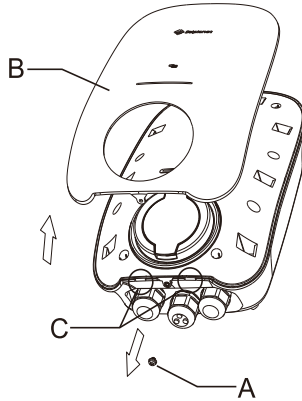

Figure 41

Installing the decorative cover

Install the following parts:

Screw (A)

Decorative cover (B)

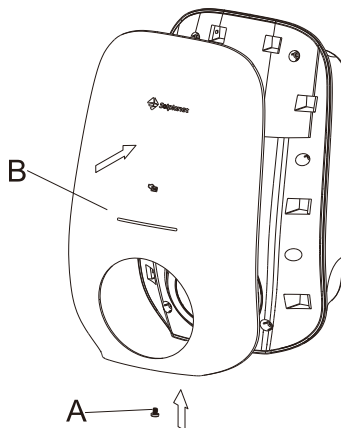

Figure 42

Removing the top cover

Remove the following parts:

Screws (A)

Top cover (B)

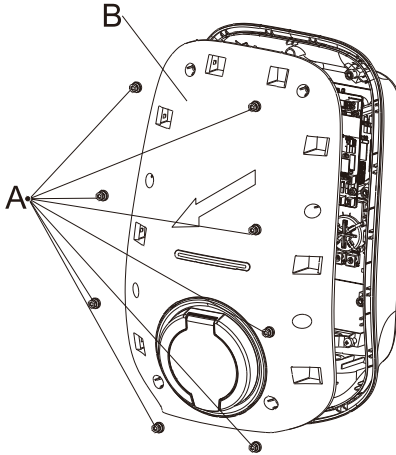

Figure 43

Installing the top cover

Install the following parts:

Screw (A)

Top cover (B)

The recommended torque is 0.8Nm.

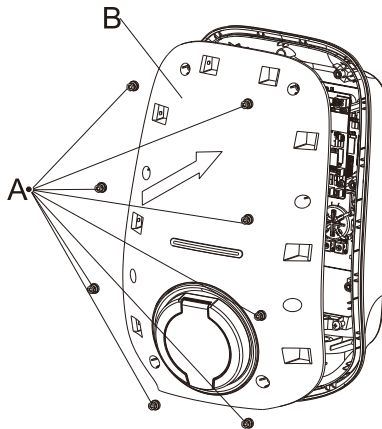

Figure 44

6 Commissioning and operation

NOTICE

Risk of injury due to incorrect installation!

- We strongly recommend carrying out preliminary checks before commissioning to avoid possible damage to the device caused by faulty installation.

6.1 Mechanical checks

Carry out the main mechanical checks to ensure the EV charger is waterproof and ready for use.

- ① Ensure the EV charger has been correctly mounted with the supplied mounting screws.
- ② Ensure the AC input cable has been correctly installed.

⚠ Warning!

If the AC input cable neutral line is connected opposite to the L line, the EV charger will become damaged due to the higher voltage.

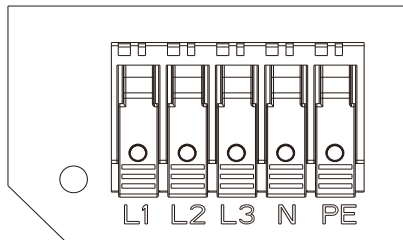

Figure 45

- ③ Ensure the communication cable has been correctly wired and secured.
- ④ Ensure the cable gland has been correctly installed and secured.

6.2 Electrical checks

Carry out the main electrical tests as follows:

- ① Close the circuit breaker or isolating device that supplies power to the EV charger.



DANGER

Danger to life due to the presence of AC voltage!

- Only touch the insulation of the AC cables.
- Do not touch the electrical live parts of the EV charger.
- Wear personal protective equipment such as insulating gloves.

- ② The EV charger will carry out a series of self-tests (duration of approx. 10 seconds).
- ③ The LEDs will illuminate ice blue after the self-tests, if there is an error, the LED will illuminate red.

6.3 Establish a connection to the Ai-charging app

Requirement:

A mobile device with the Ai-charging app.

- ① Download the Ai-charging app from the Google Play Store or Apple Store.
- ② Start the Ai-charging app.
- ③ Follow the instructions in the Ai-charging app user manual for set-up and operation.

Remark: the Ai-charging app can establish a direct connection via BLE, WIFI, or Ethernet, depending on EV chargers' hardware. For detailed information, please refer to the Ai-charging app user manual.

6.4 Activate the RFID card

Requirement:

The EV charger should be powered on, and the charging cable disconnected from the electric vehicle.

- ① Place RFID card in the front of the card reader on the EV charger.
- ② The EV charger will emit a “beep” and the LED strip will turn ice blue and

blink twice, which means that the card has been successfully bound and activated. (Max 3 RFID cards can be bound to one EV charger.)

6.5 Charging EV

Charging with the cable version EV charger

- ① Connect the EV charger charging cable to the electric vehicle, the colour of the EV charger LED strip changes from green to ice blue.
- ② Start the EV charger with the Ai-charging app or RFID card.
- ③ The EV charger begins charging the electric vehicle.

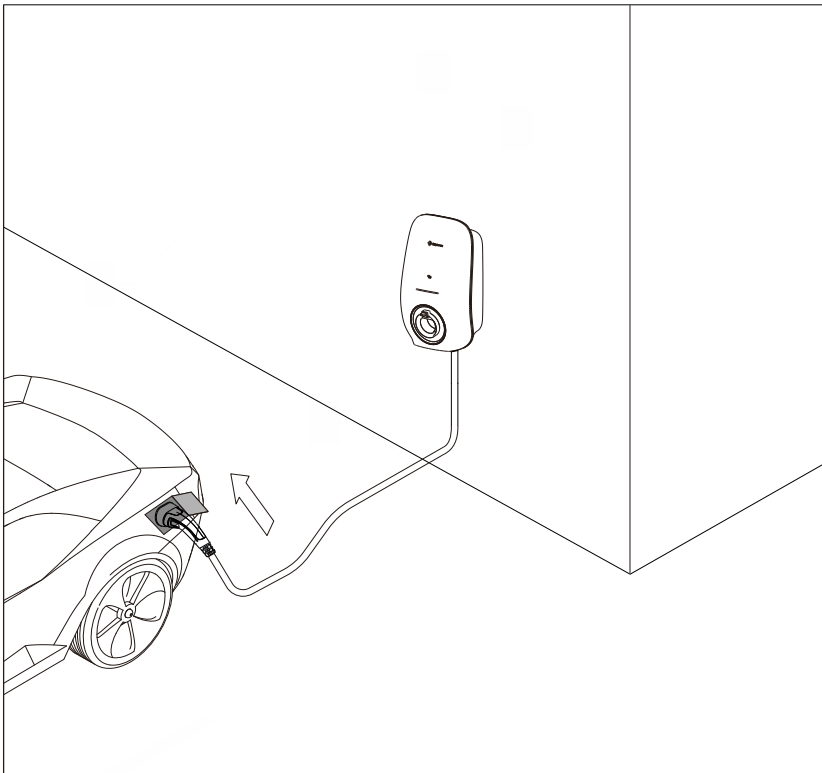

Figure 46

Start charging with the socket version EV charger

- ① Connect the charging cable to the EV charger and to the electric vehicle, the colour of the EV charger LED strip changes from green to ice blue. Wait for 5s, and the EV charger will lock the charging cable connector automatically.
- ② Start the EV charger with the Ai-charging app or RFID card
- ③ The EV charger begins charging the electric vehicle.

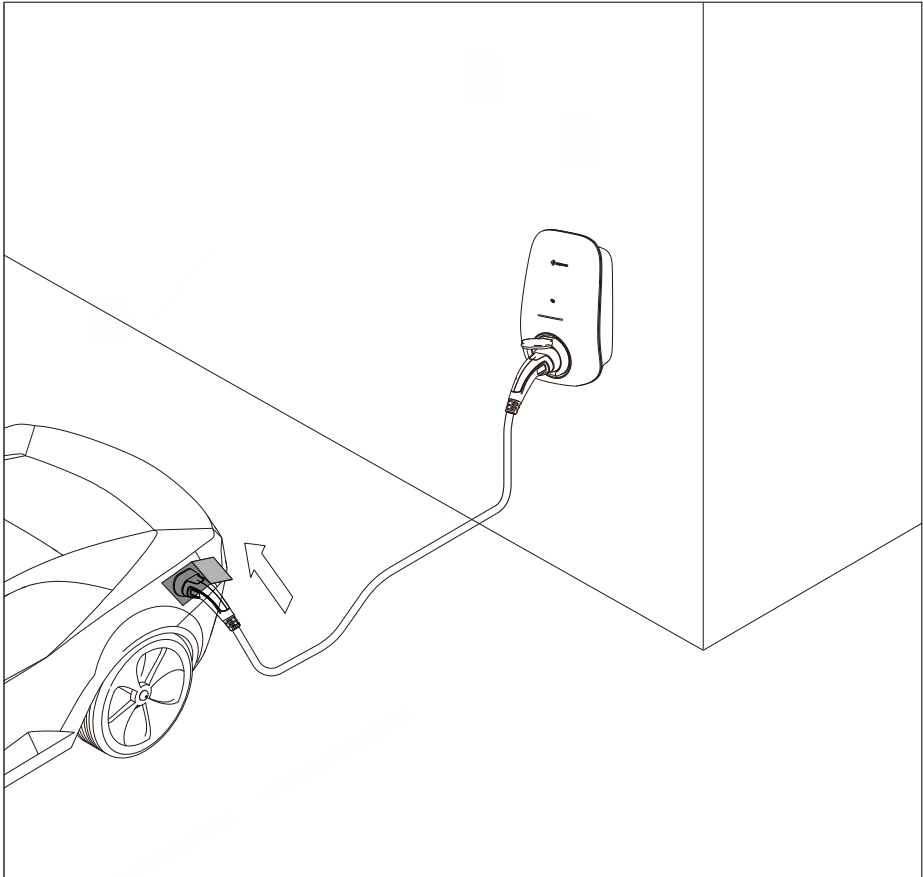

Figure 47

6.6 Stop charging

Stop charging with the cable version EV charger

- ① Stop the EV charger with the Ai-charging app or RFID card.
- ② The EV charger stops charging the electric vehicle. The colour of the EV charger LED strip changes from pulsing blue/green/ice blue to ice blue.
- ③ Disconnect the charging cable from the electric vehicle, the colour of the EV charger LED strip changes from ice blue to green.
- ④ Wrap the charging cable around the enclosure.

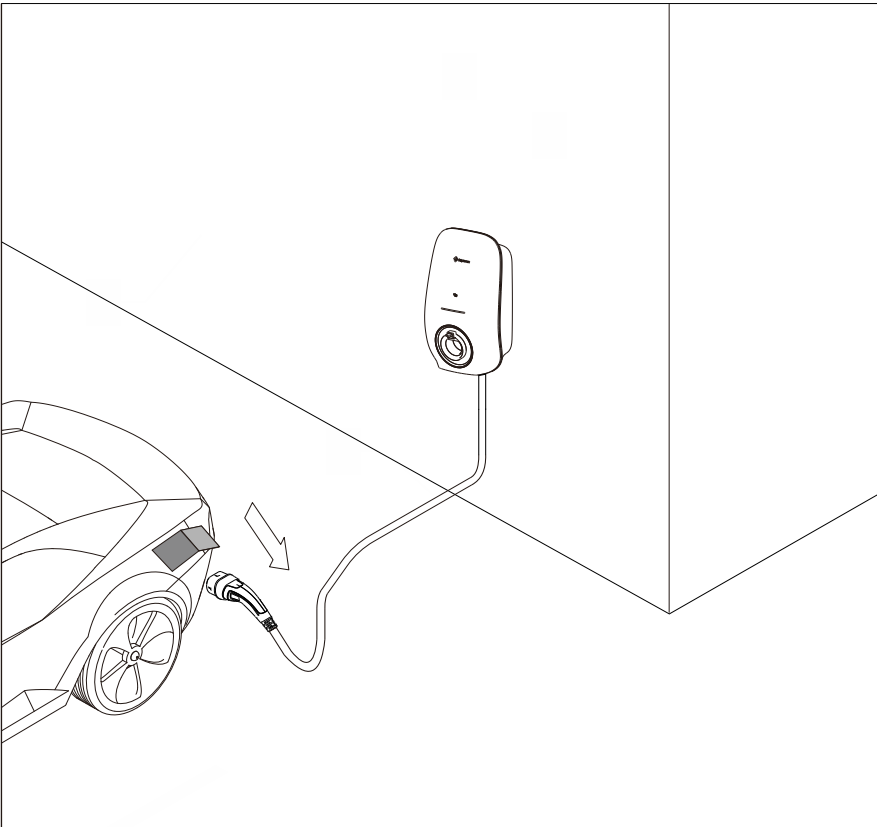

Figure 48

Stop charging with the socket version EV charger

- ① Stop the EV charger with the Ai-charging app or RFID card.
- ② The EV charger stops charging the electric vehicle. The colour of the EV charger LED strip changes from pulsing blue/green/ice blue to ice blue.
- ③ Disconnect the charging cable from the electric vehicle, the colour of the EV charger LED strip changes from ice blue to green.
- ④ The EV charger unlocks the charging cable.
- ⑤ Disconnect the charging cable from the EV charger.

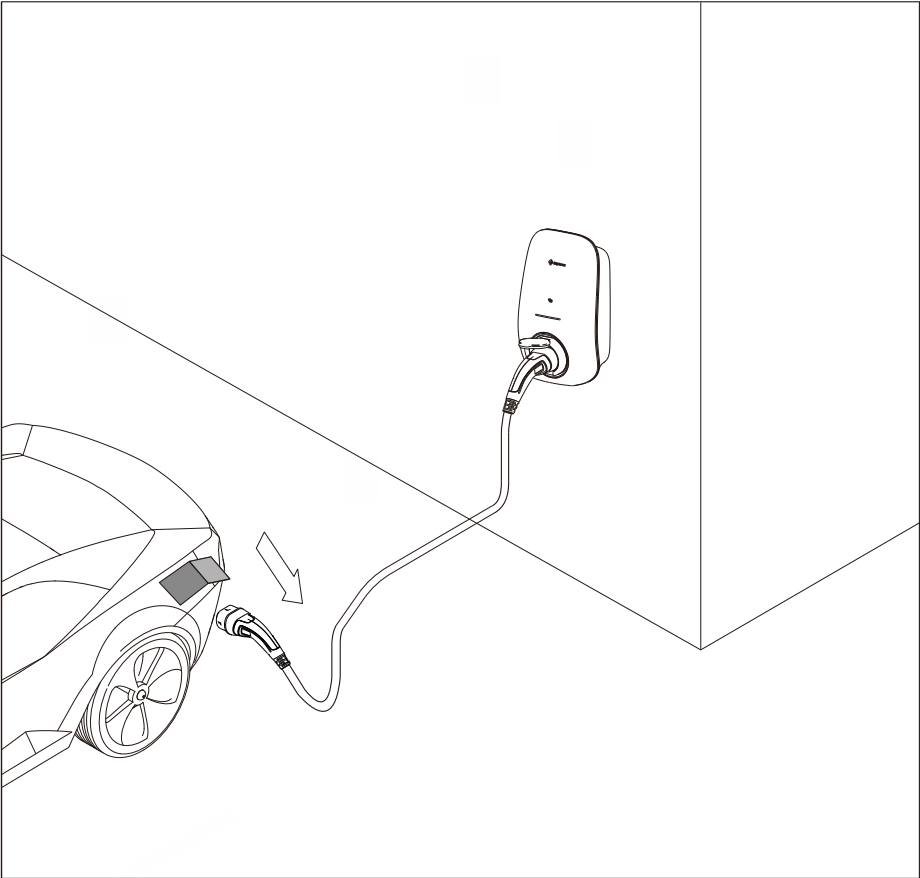

Figure 49

7 Cleaning and Maintenance

Normally, the EV charger requires minimal maintenance with no need for calibration. It is good practice to regularly inspect the EV charger and the cables for visible damage. Disconnect the EV charger from all power sources before cleaning with a soft cloth.



CAUTION

Risk of injury due to hot enclosure!

- The enclosure temperature may exceed 50 during operation. Do not come into contact with the EV charger during operation.
- Wait approx. 10 minutes before cleaning until the enclosure is cool enough to touch.
- Ground yourself before touching any component.

The charging cable must be regularly checked for any damage or deterioration.



Figure 50

8 Troubleshooting

When the EV charger appears not to be operating as per this manual, we recommend the following troubleshooting steps. If an error occurs, the error messages are displayed by the LED strip blinking red. There will be "Event Messages" displayed in the Ai-charging app. The troubleshooting steps are as follows:

Sheet 12

Red LED Status	Causes	Solution
No light	No power or incorrect connection or EV charger fault or PEN is disconnected in TN-C system.	Please check if the circuit breaker is turned on and supply cables are connected securely and correctly.
Blinking - once	The EV charger detects a charging CP signal error.	Please contact the Solplanet service provider.
Blinking - twice	The EV charger detects a PEN fault.	Please contact the Solplanet service provider.
Blinking - 3 times	The EV charger detects that the supply voltage is too high.	Please check that the supply voltage is between 185 and 275V. If it is not within this range, please contact your local electricity supplier. If it is within this range, please contact the Solplanet service provider.
Blinking - 4 times	The EV charger detects that the supply voltage is too low.	Please check that the supply voltage is between 185 and 275V. If it is not within this range, please contact your local electricity supplier. If it is within this range, please

		contact the Solplanet service provider.
Blinking - 5 times	The EV charger detects over current.	Please contact the Solplanet service provider if it occurs frequently.
Blinking - 6 times	The EV charger detects that the leakage current is over the prescribed limit.	Please contact the Solplanet service provider.
Blinking - 7 times	The EV charger detects an RCD module fault.	Please contact the Solplanet service provider.
Blinking - 8 times	The EV charger detects a Phase loss fault.	Please contact the Solplanet service provider.
Blinking - 9 times	The EV charger detects a short circuit on the output terminal or a cable short.	Please contact the Solplanet service provider.
Blinking - 10 times	The EV charger detects an internal meter device fault.	Please contact the Solplanet service provider.
Blinking - 11 times	The EV charger detects a relay fault.	Please contact the Solplanet service provider.
Blinking - 12 times	The EV charger detects an overtemperature fault.	Please check whether the ambient temperature around the EV charger is too high or whether it is exposed to direct sunlight. Please stop charging for a few hours and wait for the temperature of the EV charger to cool down. Contact the Solplanet service

		provider if it occurs frequently.
Blinking - 13 times	The EV charger detects a low temperature fault.	Please check whether the ambient temperature around the EV charger is too low. Please stop charging for a few hours and wait for the temperature of the EV charger to heat up. Please contact the Solplanet service provider if it occurs frequently.
Blinking - 14 times	The EV charger detects an over-frequency fault.	Please check that the power supply frequency is between 49Hz and 61Hz. If it is not within this range, please contact your local electricity supplier. If it is within this range, please contact the Solplanet service provider.
Blinking - 15 times	The EV charger detects an under-frequency fault.	Please check that the power supply frequency is between 49Hz and 61Hz. If it is not within this range, please contact your local electricity supplier. If it is within this range, please contact the Solplanet service provider.
18 times	Electronic lock fault	Please contact the Solplanet service provider.
others	/	Please contact the Solplanet service provider.

9 Technical data

9.1 Inputs and Outputs (AC)

Sheet 13

Parameter	SOL7.4H (1P)	SOL11H (3P)	SOL22H (3P)
Rated active power	7.4kW	11kW	22kW
Rated AC input voltage	230V	400V	
AC power frequency	50/60Hz		
Standby power consumption	<5W		
Max. output current	32A	16A	32A
Max. output overcurrent protection	35.2A	18A	35.2A
Conductor cross-section, rigid or flexible	3x6mm ²	5x4mm ²	5x6mm ²

9.2 General data

Sheet 14

General data	7.4kW / 11kW / 22kW	
	Cable Version	Socket Version
Communication	WIFI/BLE/RS-485/LAN ¹	
RFID/NFC Reader	●	
Status Indication	LED Light Strip	
Smart App	●	
Degree of protection	IP65 (Enclosure)	
Operating Temperature	-25°C...+50°C	
Storage Temperature	-40°C...+70°C	
Relative Humidity	5%-95% Non-condensing	
Altitude	Up to 2000m	
Cooling Concept	Natural Convection	
Impact Protection Class	IK10	
Connector Type	Type 2 cable	Type 2 socket ^{2, 3}
UV Resistant	●	
Mounting	Wall	
Dimensions (W/H/D)	230/360/130mm	
Weight	6kg	2.5kg
Cable Holder	●	-
Cable Length	5m/7.5m	-
Color	● Morandi Blue / ● Black	

Remark:

● Standard features / ○ optional features / – not available

1) LAN is optional

2) Self-closing cover and built-in electronic lock is standard

3) Shutter for cover is optional

Optional energy meter is needed or must be installed for solar charging function and Dynamic Load Balancing.

Type2 Plug

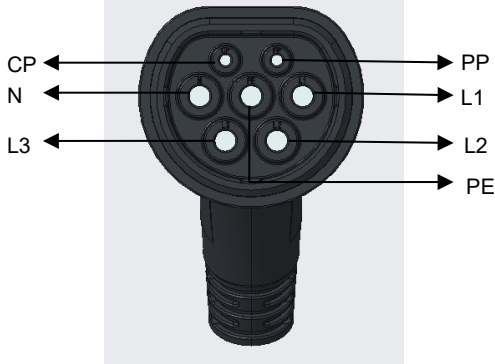

Type2 Socket

Type2 Socket with Shutter

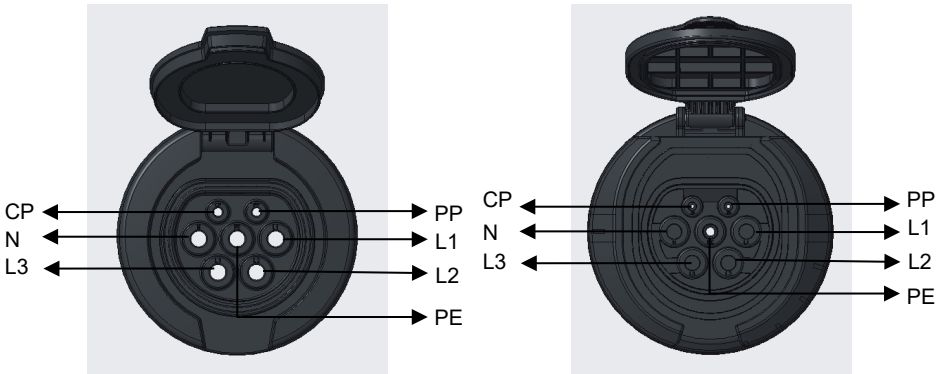

Figure 51



The Shutter version socket connector has a shutter on the conductor pins to prevent accidental contact. Shutter version is mandatory in France.

9.3 Safety regulations

Sheet 15

Protective devices	7.4kW / 11kW / 22kW
Residual Current Detection	DC 6mA
DC Leakage Protection	•
Surge Protection (EN60664)	• (Type III)
Certification	CE, TUV/EN/IEC 61851-1
Overvoltage category	III(AC)
Over current	Integrated
Over/Under Voltage	
Ground fault	
Over temperature	

10 Recycling and disposal

1. This device is used to charge electric vehicles and is subject to the EU directive 2012/19/EU on waste electrical and electronic equipment (WEEE).
2. Disposal must be according to national and regional Regulations for electrical and electronic equipment respectively.
3. Old devices and batteries must not be disposed of with household waste or bulky waste. Before the device being disposed of should it be rendered inoperable.
4. Dispose of the packaging material in the region's usual collection container for cardboard, paper, and plastics.



11 EU declaration of conformity

Within the scope of the EU directives:

- Electromagnetic compatibility 2014/30/EU (L 96/79-106, March 29, 2014)(EMC)
- Low voltage directive 2014/35/EU (L 96/357-374, March 29, 2014)(LVD)
- Radio equipment directive 2014/53/EU (L 153/62-106, May 22, 2014)(RED)



AISWEI New Energy Technology (Yangzhong) Co., Ltd. confirms herewith that the EV chargers mentioned in this document are in compliance with the fundamental requirements and other relevant provisions of the above mentioned directives.

The entire EU Declaration of Conformity can be found at www.solplanet.net.

12 Contacts

If you have any technical problems with our products, please contact our service.

Provide the following information when you initiate a service request:

- EV charger type
- EV charger serial number
- Error code (LED flash code / status)
- Mounting location
- Proof of purchase

Service Contact:

Website: <https://solplanet.net/contact-us/>

You can submit your claims online by visiting website:

<https://solplanet.net/claims/>

You will receive a response within 24 hours.

AISWEI New Energy Technology (Yangzhong) Co., Ltd.

Add.: No.588 Gangxing Road, Yangzhong Jiangsu, China

Web: <https://solplanet.net>



