



ASW3000H-S2/ASW3680H-S2/ASW4000H-S2/
ASW5000H-S2/ASW6000H-S2

Single phase hybrid inverter

User Manual

Contents

1	General information	3	8.1	Brief introduction.....	57
1.1	About this document.....	3	8.2	Download and install.....	57
1.2	Product validity.....	3	8.3	Create an account.....	57
1.3	Target group.....	3	8.4	Create a plant	59
1.4	Symbols	4	8.5	Setting parameters	65
2	Safety.....	5	9	Decommissioning the product	79
2.1	Intended use	5	9.1	Disconnecting the inverter from voltage sources.....	79
2.2	Important safety instructions.....	5	9.2	Dismantling the inverter	81
2.3	Symbols on the label.....	8	10	Technical data	82
3	Unpacking and storage.....	9	10.1	ASW3000H/3680H/4000H/5000H/6000H-S2	82
3.1	Scope of delivery	9	10.2	General data	83
3.2	Product storage	9	10.3	Protective device.....	84
4	Inverter overview.....	11	11	Troubleshooting	85
4.1	Product description.....	11	12	Maintenance	91
4.2	Dimensions.....	11	12.1	Cleaning the contacts of the DC switch	91
4.3	LED indicator	12	12.2	Cleaning air inlet and outlet	91
4.4	Supported grid types.....	12	13	Recycling and disposal.....	92
4.5	Interfaces and functions	13	14	EU declaration of conformity	92
4.6	Basic system solution	15	15	Service and warranty	92
4.7	Energy Management.....	18	16	Contact.....	93
5	Mounting	27			
5.1	Requirements for mounting.....	27			
5.2	Taking out and moving the product	28			
5.3	Mounting.....	29			
6	Electrical connection.....	32			
6.1	Connection port description	32			
6.2	Connecting additional grounding.....	33			
6.3	Grid cable connection	34			
6.4	EPS Load cable connection	38			
6.5	DC connection.....	40			
6.6	Battery connection	47			
6.7	Wi-Fi stick connection	50			
6.8	BMS CAN cable connection.....	51			
6.9	DRED cable connection.....	52			
6.10	Smart meter cable connection.....	53			
7	Commissioning and operating	56			
7.1	Inspection before commissioning	56			
7.2	Commissioning procedure.....	56			
8	Solplanet APP	57			

1 General information

1.1 About this document

This document describes the mounting, installation, commissioning, configuration, operation, troubleshooting and decommissioning of the product as well as the operation of the product user interface.

You will find the latest version of this document and further information on the product in PDF format at www.solplanet.net.

It is recommended that this document is stored in an appropriate location and be available at all times.

1.2 Product validity

This document is valid for the following models:

- ASW3000H-S2
- ASW3680H-S2
- ASW4000H-S2
- ASW5000H-S2
- ASW6000H-S2

1.3 Target group

This document is intended for qualified persons who must perform the tasks exactly as described in this user manual.

All installation work must be performed by appropriately trained and qualified persons.

Qualified persons must possess the following skills:

- Knowledge of how an inverter works and is operated.
- Knowledge of how batteries work and are operated.
- Training in how to deal with the dangers and risks associated with installing, repairing and using electrical devices, batteries and installations.
- Training in the installation and commissioning of electrical devices.
- Knowledge of all applicable laws, standards and directives.
- Knowledge of and compliance with this document and all safety information.

1.4 Symbols

DANGER

Indicates a hazardous situation which, if not avoided, will result in death or serious injury.

WARNING

Indicates a hazardous situation which, if not avoided, could result in death or serious injury.

CAUTION

Indicates a hazardous situation which, if not avoided, could result in minor or moderate injury.

NOTICE

Indicates a situation which, if not avoided, can result in property damage.



Information that is important for a specific topic or goal, however not related to safety.

2 Safety

2.1 Intended use

- The product is a transformerless hybrid inverter with 2 MPP trackers and a battery connection that feeds the direct current of the PV array into the connected battery or converts it to grid-compliant single-phase current and then feeds it into the utility grid. The product also can convert the DC current supplied by the battery into grid-compliant single-phase current. The product also can convert the AC current supplied by the grid into battery current.
- The product has a backup function that can continue to supply selected circuits with power from the battery or PV system in the event of a grid fault.
- The product also can convert the direct current supplied by the battery into grid-compliant single-phase current. The product is intended for indoor and outdoor applications.
- The product must only be connected with PV modules of protection class II (in accordance with IEC 61730, application class A). Do not connect any sources of energy other than PV modules and batteries to the product.
- PV modules with a high capacitance to ground must only be used if their coupling capacitance is less than 1.5µF.
- The product is not equipped with an integrated transformer and therefore has no galvanic isolation. The product must not be operated with PV modules which require functional grounding of either the positive or negative PV conductors. This can cause the product to be irreparably damaged. The product may be operated with PV modules with frames that require protective earthing.
- The inverters shall not be used in multiple phase combinations.
- All components must remain within their permitted operating ranges and their installation requirements at all times.
- Use the product only in accordance with the information provided in the user manual and with the locally applicable standards and directives. Any other application may cause personal injury or damage to property.
- The product must only be operated in connection with an intrinsically safe lithium-ion battery approved by AISWEI. The entire battery voltage range must be completely within the permissible input voltage range of the product.
- The product must only be used in countries for which it is approved by AISWEI and the grid operator.
- Knowledge of all applicable laws, standards and directives.
- Knowledge of and compliance with this document and all safety information.
- The type label must be permanently attached to the product and must be in a legible condition.
- This document does not replace any regional, state, provincial, federal or national laws, regulations or standards that apply to the installation, electrical safety and use of the product.

2.2 Important safety instructions

The product has been designed and tested strictly according to the international safety requirements. As with all electrical or electronical devices, there are residual risks despite careful construction. To prevent personal injury and property damage and to ensure long-term operation of the product, read this section carefully and observe all safety information at all times.



Danger to life due to high voltages of the PV array or the battery!

The DC cables connected to the battery or the PV array may be live. Touching the DC conductors or the live components can cause to lethal electric shocks. If you disconnect the DC connectors from the product under load, an electric arc may occur leading to electric shock and burns.

- Do not touch non-insulated cable ends.
- Do not touch the DC conductors.
- Do not touch any live components of the product.
- Do not open the product.
- Observe all safety information of the battery manufacturer.
- All work on the product must only be carried out by qualified personnel who have read and fully understood all safety information contained in this document and the user manual.
- Disconnect the product from all voltage and energy sources and ensure it cannot be reconnected before working on the product.
- Wear suitable personal protective equipment for all work on the product.

DANGER

Danger to life due to electric shock when touching live components in backup mode !

Even if the AC breaker and the PV switch of the inverter are disconnected, the parts of the system may still be live when the battery is switched on due to backup mode.

- Do not open the product.
- Disconnect the product from all voltage and energy sources and ensure it can not be reconnected before working on the product.

DANGER

Danger to life due to fire or explosion when batteries are fully discharged !

Danger to life due to fire or explosion when batteries are fully discharged.

- Make sure that the battery is not fully discharged before commissioning the system.
- Contact the battery manufacturer for further proceedings if the battery is fully discharged.

DANGER

Danger to life due to burns caused by electric arcs through short-circuit currents !

Short-circuit currents in the battery can cause heat accumulation and electric arcs if the battery is short circuited or wrongly installed. Heat accumulation and electric arcs may result in lethal injuries due to burns.

- Disconnect the battery from all voltages sources prior to performing any work on the battery.
- Only use properly insulated tools to prevent accidental electric shock or short circuits during installation.
- Observe all safety information of the battery manufacturer.

DANGER

Danger to life due to electric shock when touching live system components in case of a ground fault !

If a ground fault occurs, parts of the system may still be live. Touching live parts and cables may result in death or lethal injuries due to electric shock.

- Disconnect the product from voltage and energy sources and ensure it cannot be reconnected before working on the device.
- Only touch the cables of the PV modules on their insulation.
- Do not touch any parts of the substructure or frame of the PV array.
- Do not connect PV strings with ground faults to the product.

WARNING

Danger to life due to electric shock from destruction of the measuring device due to overvoltage!

Overvoltage can damage a measuring device and result in voltage being present in the enclosure of the measuring device. Touching the live enclosure of the measuring device results in death or lethal injuries due to electric shock.

- Only use measuring devices with the measurement span higher than the DC input voltage range

CAUTION

Risk of burns due to high temperature!

Some parts of the enclosure can become hot during operation.

- During operation, do not touch any parts other than the enclosure lid of the product.

CAUTION

Risk of injury due to weight of product!

Injuries may result if the product is lifted incorrectly or dropped while being transported or mounted.

- Transport and lift the product carefully. Take the weight of the product into account.
- Wear suitable personal protective equipment for all work on the product.

NOTICE

Damage to the inverter due to electrostatic discharge.

Internal components of the inverter can be irreparably damaged by electrostatic discharge.

- Ground yourself before touching any component.



The country grid code set must be set correctly.

If you select a country grid code set which is not valid for your country and purpose, it can cause a disturbance in the PV system and lead to problems with the grid operator. When selecting the country grid code set, you must always observe the locally applicable standards and directives as well as the properties of the PV system (e.g., PV system size, grid-connection point).

- If you are not sure which standards and directives are valid for your country or purpose, contact the grid operator.

2.3 Symbols on the label



Beware of a danger zone!

This symbol indicates that the product must be additionally grounded if additional grounding or equipotential bonding is required at the installation site.



Beware of high voltage and operating current!

The product operates at a high voltage and current. Work on the product must only be carried out by skilled and authorized personnel.



Beware of hot surfaces!

The product can get hot during operation. Avoid contact during operation.



WEEE Designation

Do not dispose of the product together with household waste. Dispose the product in accordance with local disposal regulations for electronic waste



CE marking

The product complies with the requirements of the applicable EU directives.



Certification mark

The product has been tested by T89 and got the Tuality certification mark.



CE marking

The product complies with the requirements of the applicable EU directives.



CaSactor discharge

Danger to life due to high voltages in the inverter. Do not touch live parts for 5 minutes after disconnection from the power sources.



Observe the documentation

Read and understand all documentation supplied with the product.

3 Unpacking and storage

3.1 Scope of delivery

Check the scope of delivery for completeness and any visible external damage. Contact your distributor if the scope of delivery is incomplete or damaged.

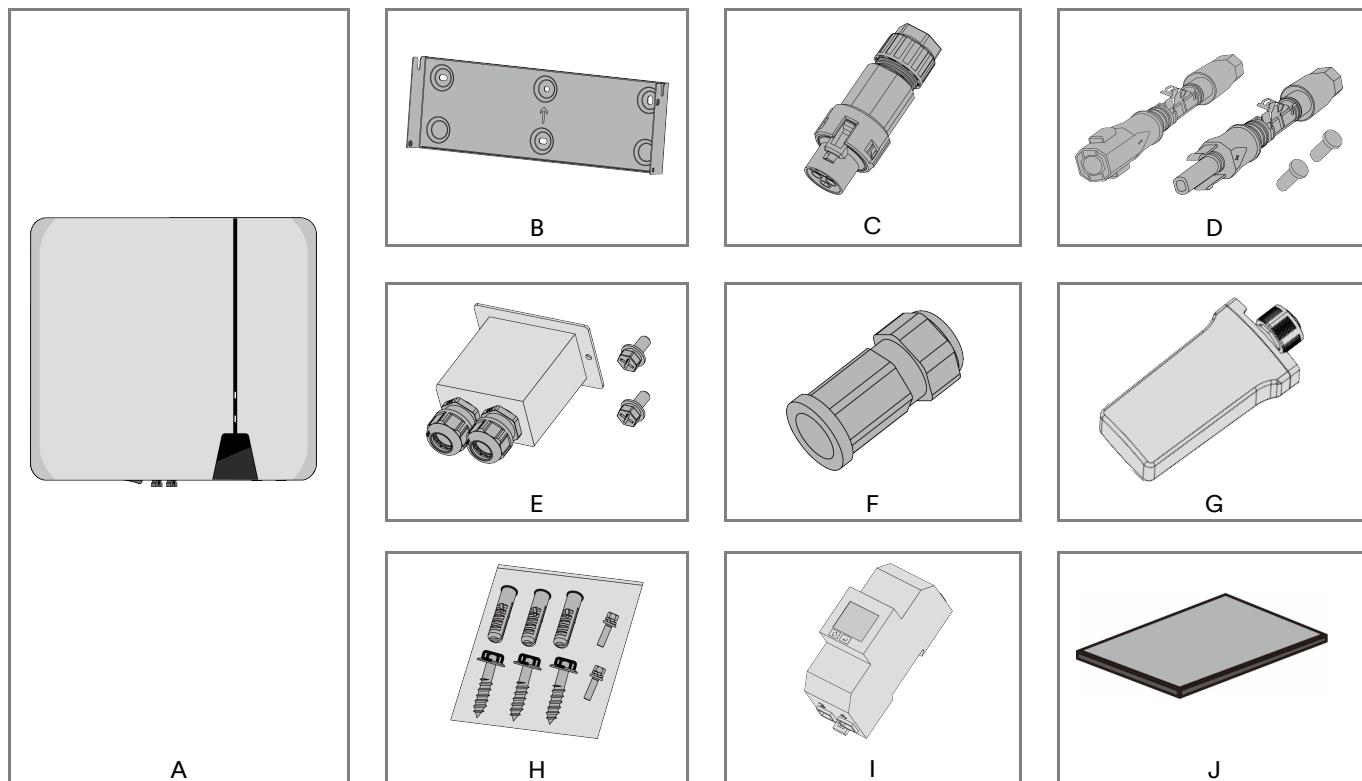

Object	Description	Quantity
A	Inverter	1
B	Wall Bracket	1
C	AC connector	2
D	DC connector	2
E	Battery terminal cover	1
F	RS485 Communication client	3
G	Communication device (WiFi stick)	1
H	Fastener package	1
I	Smart meter	1
J	Document	1

3.2 Product storage

Suitable storage is required if the inverter is not installed immediately:

- Store the inverter in the original packing case.

- The storage temperature must be between -30°C to $+70^{\circ}\text{C}$, and the storage relative humidity must be between 0 and 100%, non-condensing.
- The packing with the inverter shall not be tilted or inverted.
- The product must be fully inspected and tested by professionals(Refer to section 1.3) before it can be put into operation, if it has been stored for half a year or more.

4 Inverter overview

4.1 Product description

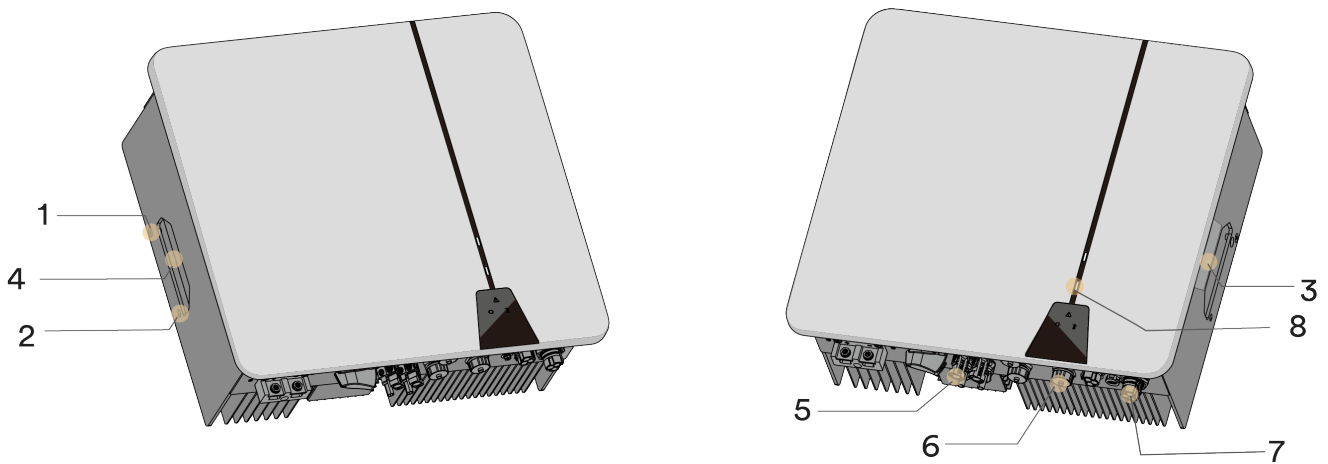
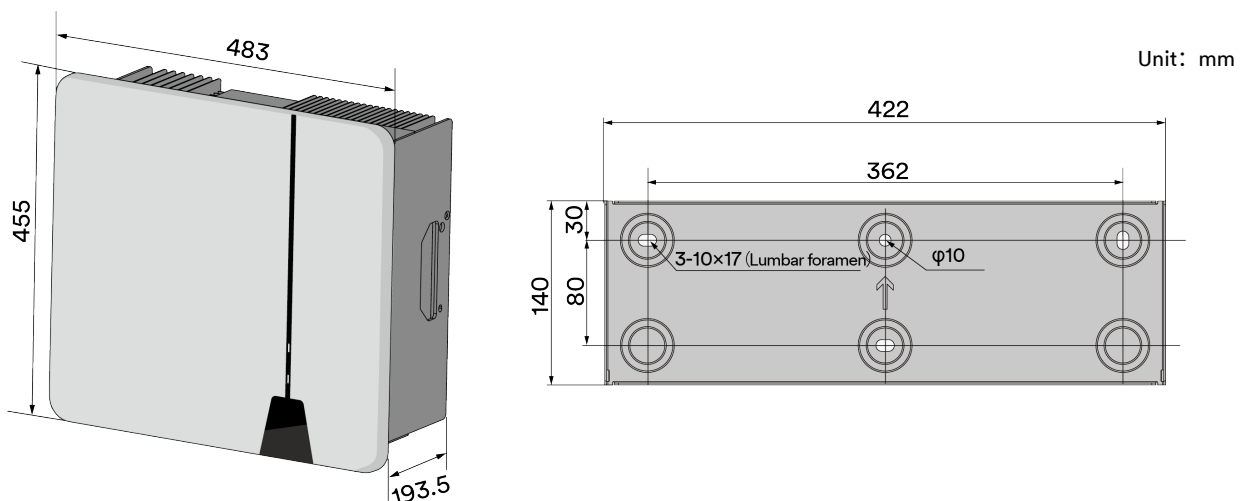





















Figure shown here is for reference only. The actual product received may differ!

Object	Name	Description
1	Mounting ears	Two ears hang the inverter onto the mounting-bracket.
2	Inverter fixed point	Two points, used for the fixed connection between the inverter and the mounting-bracket.
3	Labels	Warning symbols, nameplate, and QR code.
4	Handles	Two handles, move the product and hang the inverter onto the mounting-bracket.
5	DC wiring area	DC switches, DC terminals and BAT terminals.
6	Communication wiring area	WIFI terminals and communication cover.
7	AC wiring area	GRID terminals and EPS Load terminals.
8	Display area	LED indicator and display panel.

4.2 Dimensions



4.3 LED indicator

Function	LED	Description
SOLAR	 Glowing	The product operates normally and the solar energy is available.
	 Flashing	The product is self-checking automatically, or the firmware is updating.
	 Off	The solar energy is not available.
BAT	 Glowing	The product operates normally and the battery energy is available.
	 Flashing	The product is self-checking automatically, or the firmware is updating, or the SOC of the battery is low.
	 Off	The battery energy is not available.
ERR	 Yellow Glowing	The communication with the WiFi stick has failed.
	 Yellow Flashing	There is a warning fault, the warning message and the corresponding event number will be displayed on the product user interface.
	 Red Glowing	There is an error fault. The Error message and the corresponding event number will be displayed on the product user interface.
	 Off	The product is operating normally.
EPS	 White Glowing	The EPS port of the product operates with the loads, or in Back-up mode.
	 White Flashing	The EPS port of the product operates without the loads.
	 Red Glowing	The EPS port of the product has failed.
	 Red Flashing	The EPS port of the product operates with overload.
	 Off	The EPS port of the product stop operation.
GRID	 White Glowing	The product connects to the Grid and feeds the solar energy into the utility grid.
	 White Flashing	The product doesn't connect to the grid and operates as an off-grid mode.
	 Red Glowing	The product disconnects from the Grid due to a fault.
	 Off	The product stop operation.

For safety reasons, EPS LED white flash when there is no load or when the load power is low.

4.4 Supported grid types

The grid structures supported by the product is TN-S, TN-C, TN-C-S, TT, as shown in the figure below:

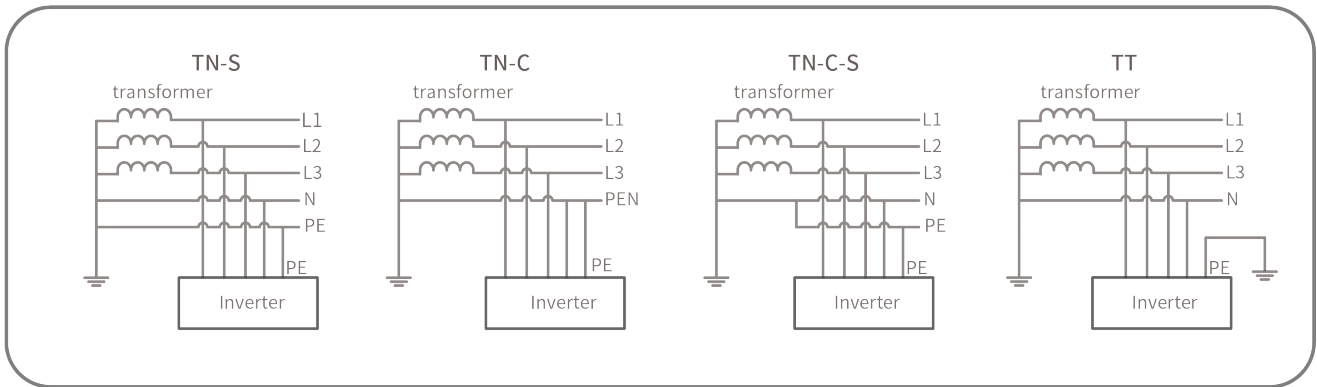

For the TT grid structure, the effective value of the voltage between the neutral wire and the ground wire must be less than 20V.

4.5 Interfaces and functions

The product is equipped with the following interfaces and functions:

WiFi stick

The product is equipped with a WiFi stick as standard, which provides a user interface for configuring and monitoring the product. The WiFi stick can connect to the Internet via WLAN or the Ethernet cable. If you don't want to use WiFi stick, the Solplanet communication products or the third-party monitor device can be chosen.

RS485 Interface

The inverter may or may not be equipped with two RS485 interfaces. The inverter can communicate with Solplanet communication products or third party devices via the RS485 interface. For more information regarding third party devices, please contact the local Solplanet service department.

Modbus RTU

The product is equipped with a Modbus interface. If the third-party communication device also complies with AISWEI Modbus protocol, which can be connected to this product.

Export active power control

The product is equipped with the export active power limit function, so as to meet the requirements of some national standards or grid standards for limiting the output power at the grid connection point.

The export active power control solution measures the active power at the point where the customer's installation is connected to the distribution system (point of grid connection) and then uses this information to control the inverter's output active power in order to prevent the export active power to the distribution system from exceeding the agreed export capacity.

The smart meter that can be used with this product must be approved by AISWEI. For more information about the smart meter, please contact the service.

Inverter demand response modes (DRED)

The product shall detect and initiate a response to all supported demand response commands according to the standard AS/NZS 4777.2.

The product only supports the demand response mode DRM 0 (see section 6.9).

Back-up function

The inverter is equipped with a back-up function which also called as an emergency power supply (EPS). The back-up function ensures that the inverter forms a Single-phase back-up grid that uses energy from the battery and the PV system that is directly connected to the inverter to supply the critical load in the event of a utility grid failure.

In the event of a grid failure, the product disconnects from the grid. The product provides a standalone grid and the backup loads, which connect to EPS connector, continue to be supplied by the energy stored in the battery and the PV modules.

The charging of the battery is ensured by the existing PV system during back-up operation.

As soon as the utility grid is available again, the product will automatically connect to the grid and the loads are supplied with energy from the utility grid.

Earth fault alarm

This product complies with IEC 62109-2 clause 13.9 for earth fault alarm monitoring. If an Earth Fault Alarm occurs, the red color LED indicator will light up. At the same time, the error code 38 will be sent to the Solplanet Cloud.

4.6 Basic system solution

The product is a high-quality inverter which can convert solar energy to AC energy and store energy into battery. The product can be used to optimize self-consumption, store in the battery for future use or feed into public grid.

The basic application of this product as follow:

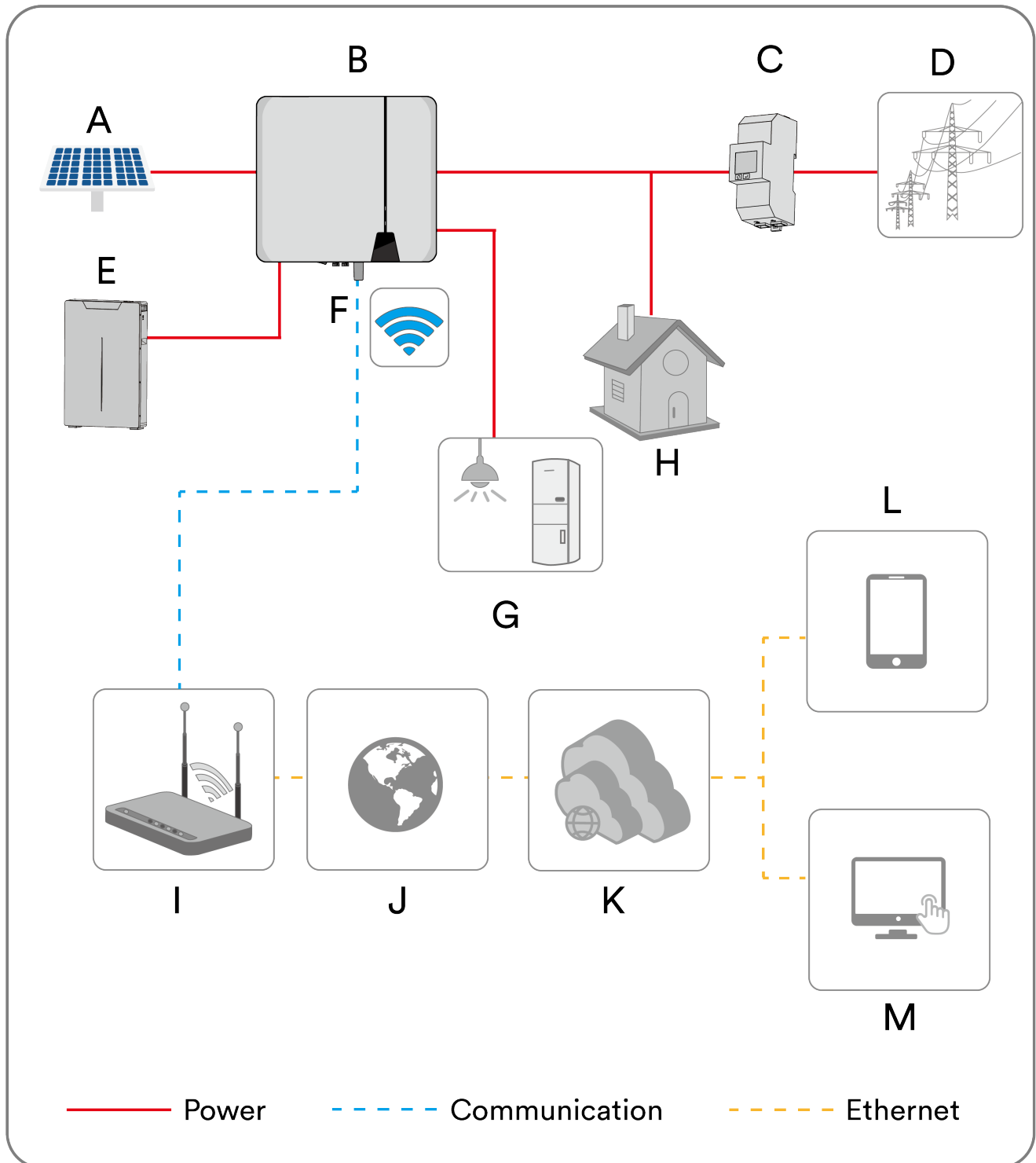

Object	Description	Remark
A	PV String	The product supports to connect the monocrystalline silicon, polycrystalline silicon, and thin-film without grounding.
B	Hybrid inverter	ASW H-S2 series products have an EPS port.
C	Smart meter	The smart meter is the central device responsible for energy management. Communicate with the inverter through the RS485 protocol.
D	Utility grid	The product can connect to TN and TT grounding system grid.
E	Battery system	The product must only be operated in connection with an intrinsically safe lithium-ion battery system approved by AISWEI.
F	WiFi-stick	The WiFi-stick supports WLAN communication.
G	EPS Load	The EPS load directly connected to the EPS port of the inverter. The EPS load can be power supplied by the inverter after the utility grid is failure.
H	Normally load	The normally load directly connected to utility grid. The normally load will be power off after the utility grid is failure.
I	Router	The product can connect to router through Wi-Fi signal.
J	Internet	The monitor information can transfer to Cloud Server through Internet.
K	Cloud server	The monitor information is stored at cloud server.
L	Smart phone	The APP can be installed on the smart phone and then review the monitor information.
M	Computer	The monitor information also can be review on the computer.

The system diagram of this product as follow:

For Australia and New Zealand, the neutral cable of On-grid side and EPS side must be connected together according to the wiring rules AS/NZS 3000. Otherwise the EPS function will not work.

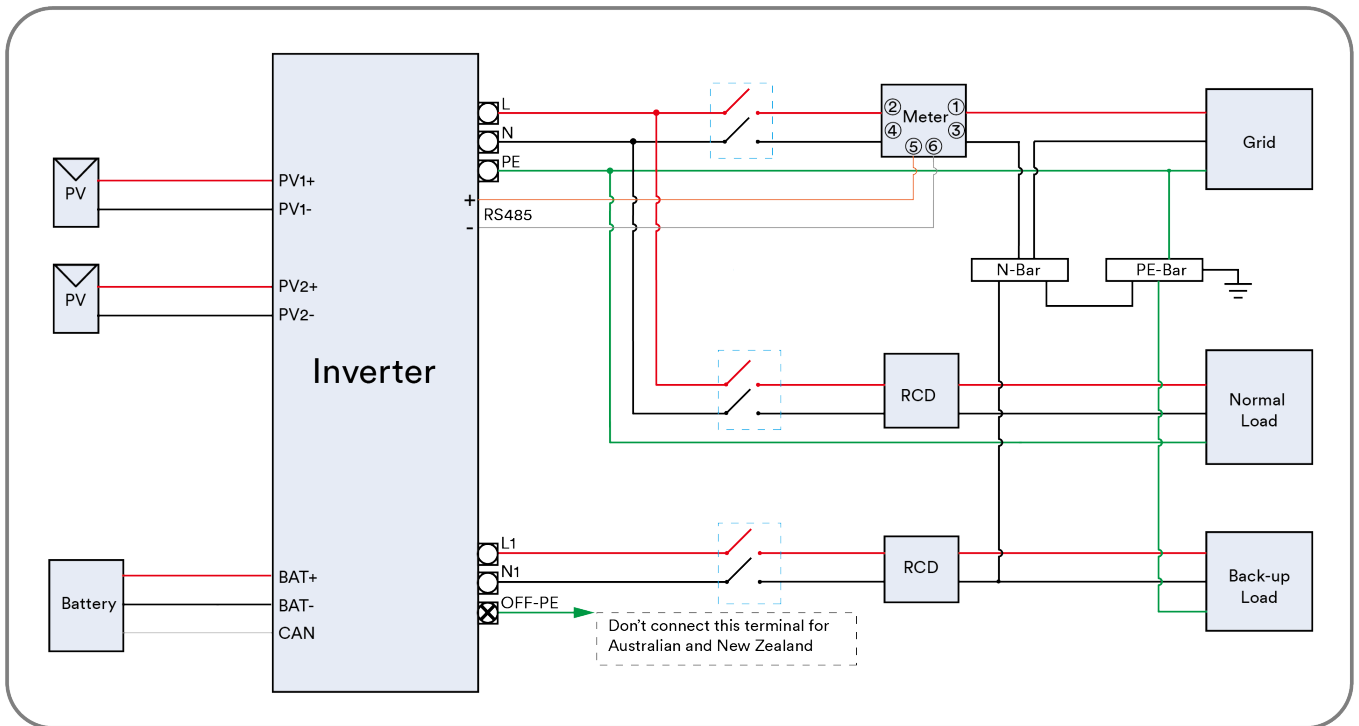

For other countries, the following diagram is an example for grid systems without special requirement on wiring connection.

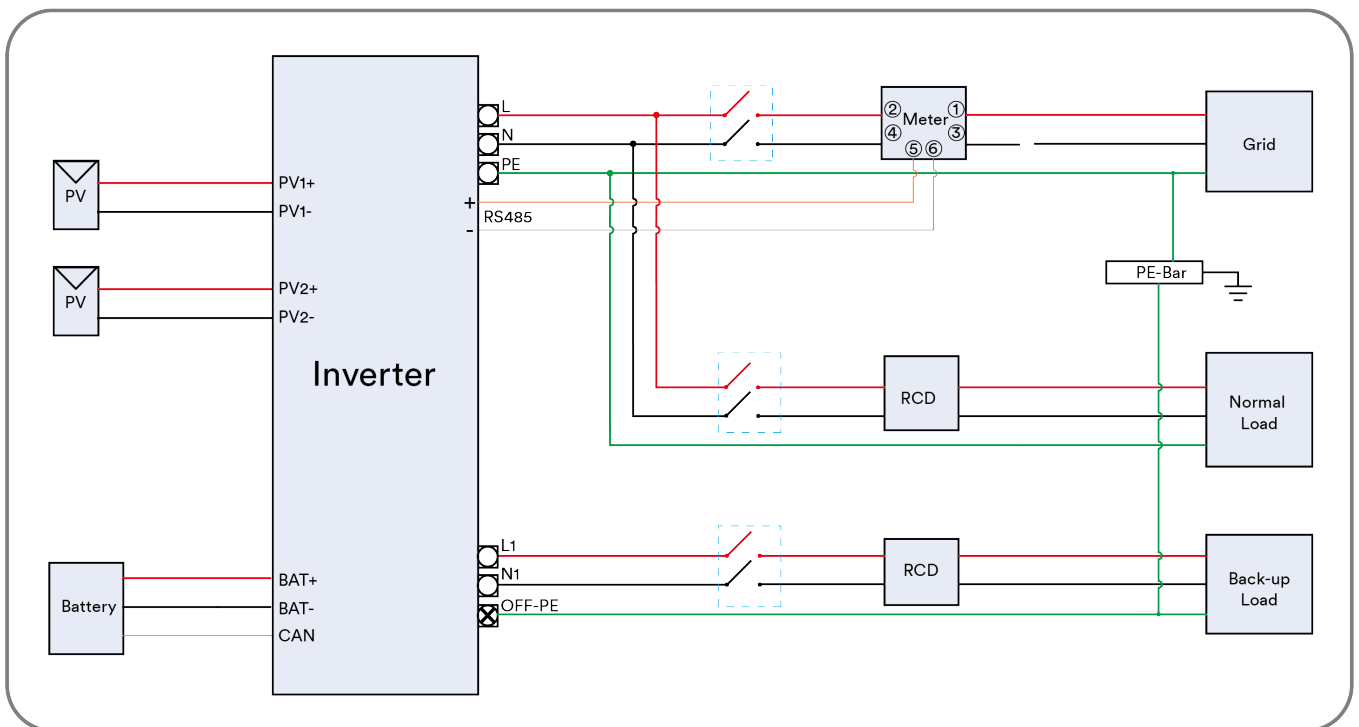

Smart meter connection refer to 6.10.2.

4.7 Energy Management

The energy management mode depends on PV energy and user's preference. There are five energy management mode can be chosen.

4.7.1 Self-Consumption mode

The photovoltaic energy is preferentially used by local load to improve the self-consumption rate and self-sufficiency rate.

The energy management during daytime:

Case 1: PV power generation is lower than the load power consumption, and the energy of the battery is not available.

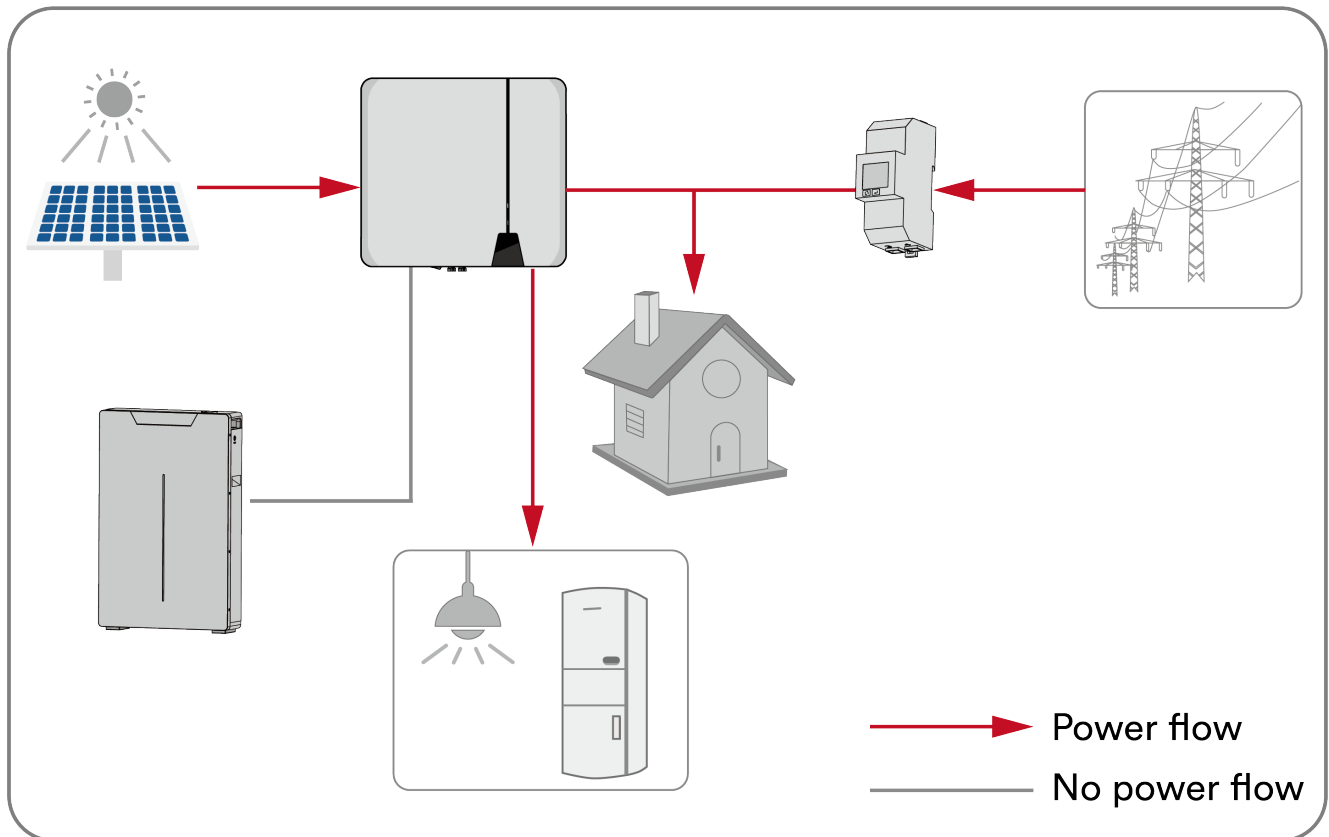

Case 2: PV power generation is lower than the load power consumption, and the energy of the battery is available.

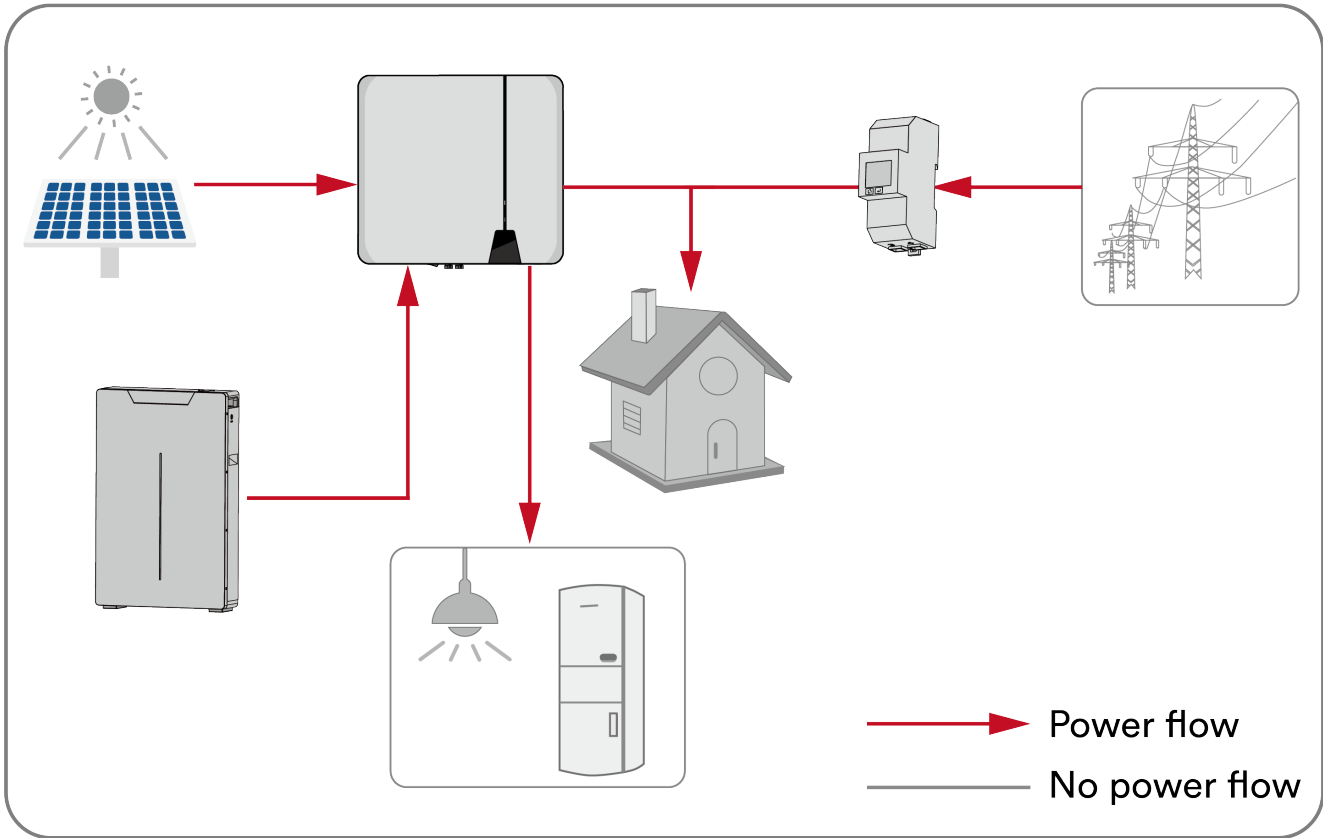

Case 3: PV power generation is larger than the load power consumption.

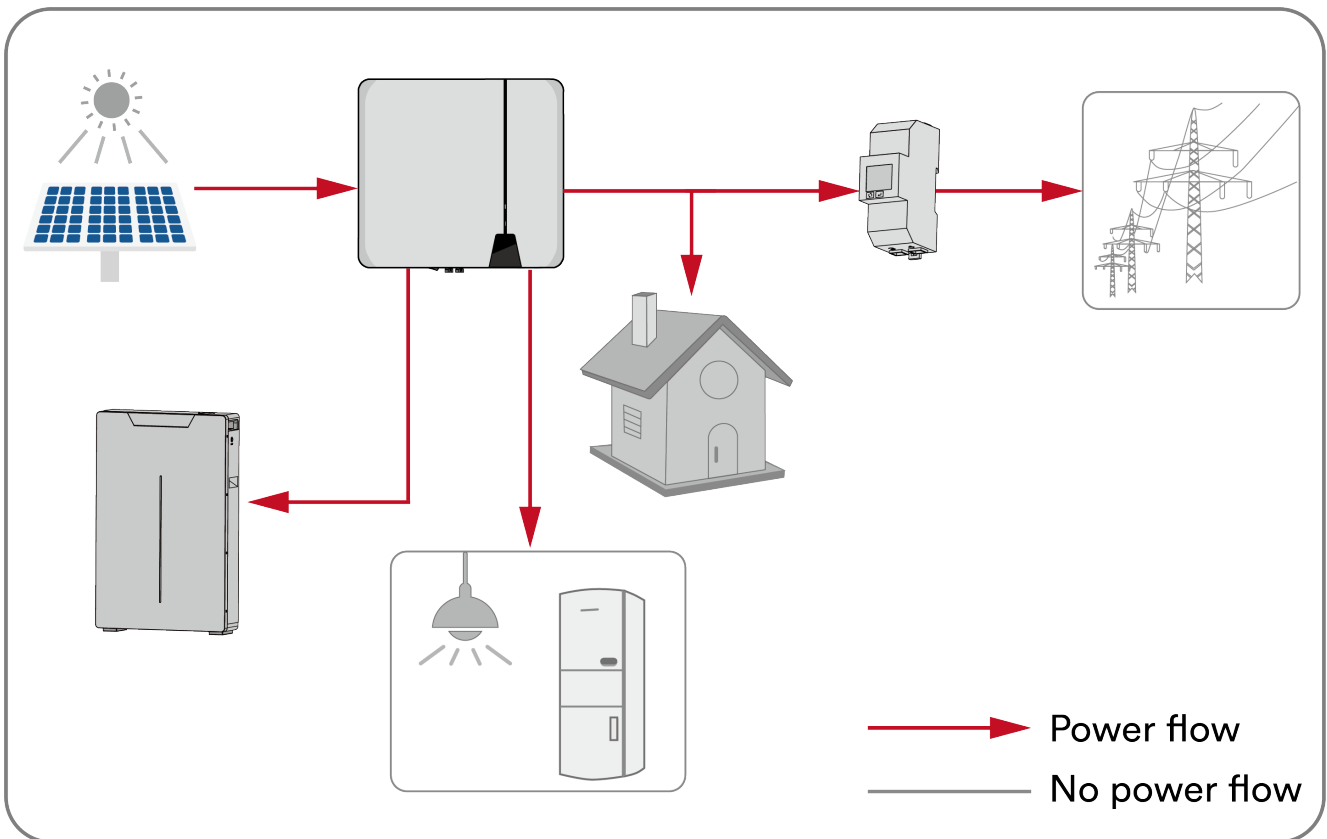

The energy management during night:

Case 1: The energy of the battery is available.

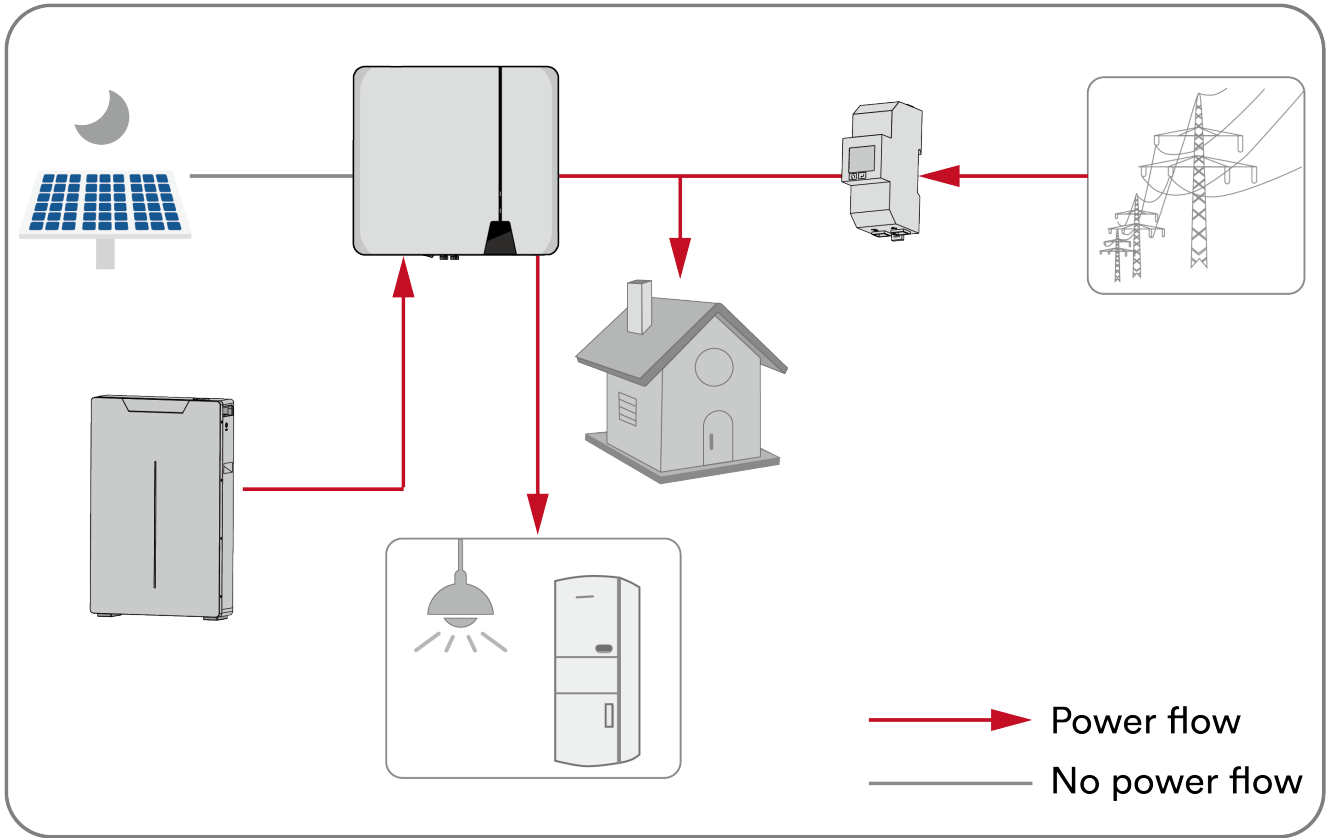

Case 2: The energy of the battery is not available.

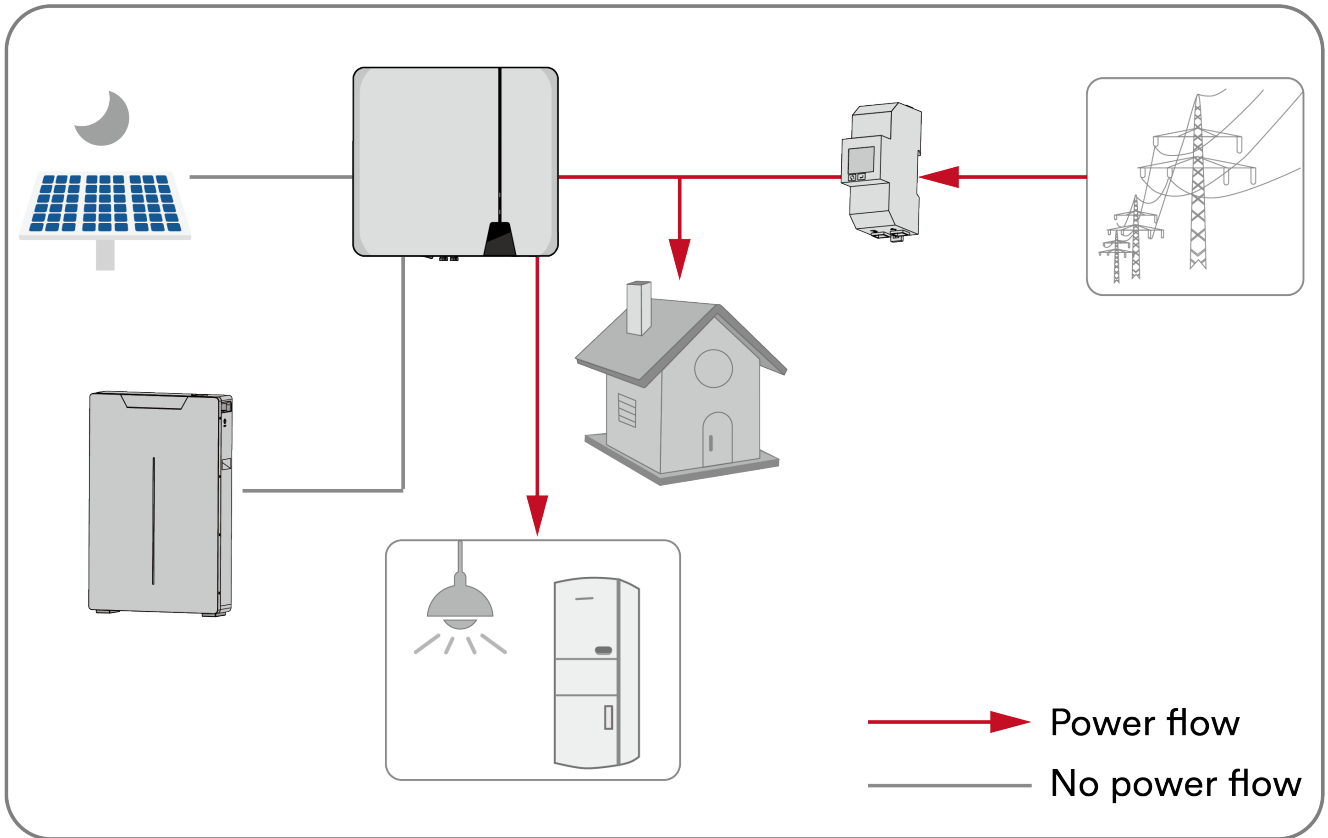

4.7.2 Back-up mode

The battery is a back-up energy storage device. The battery always charged by PV power if it is not full charged. The battery discharge only when the utility grid loss.

Case 1: The energy of the battery is not full charged.

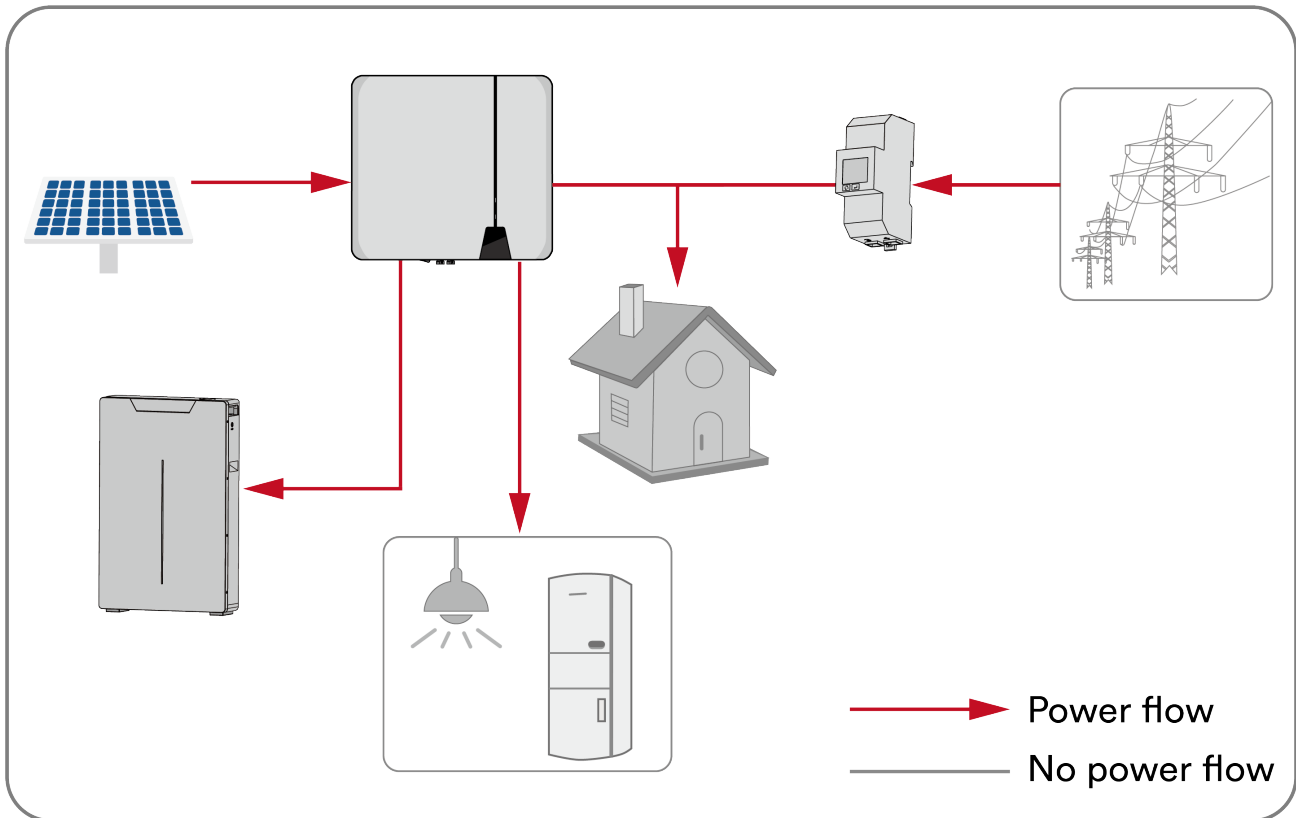

Case 2: The energy of the battery is full charged, even at night.

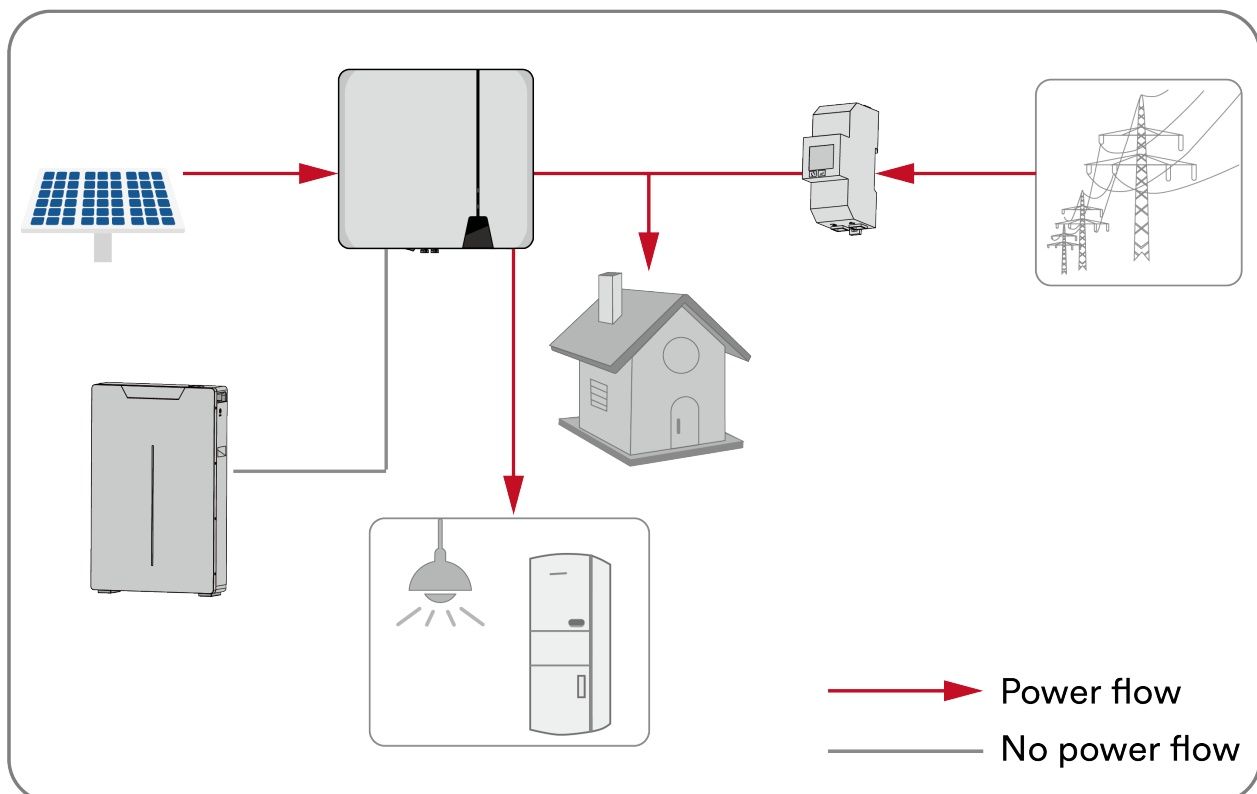

Case 3: The battery discharge when the utility grid loss.

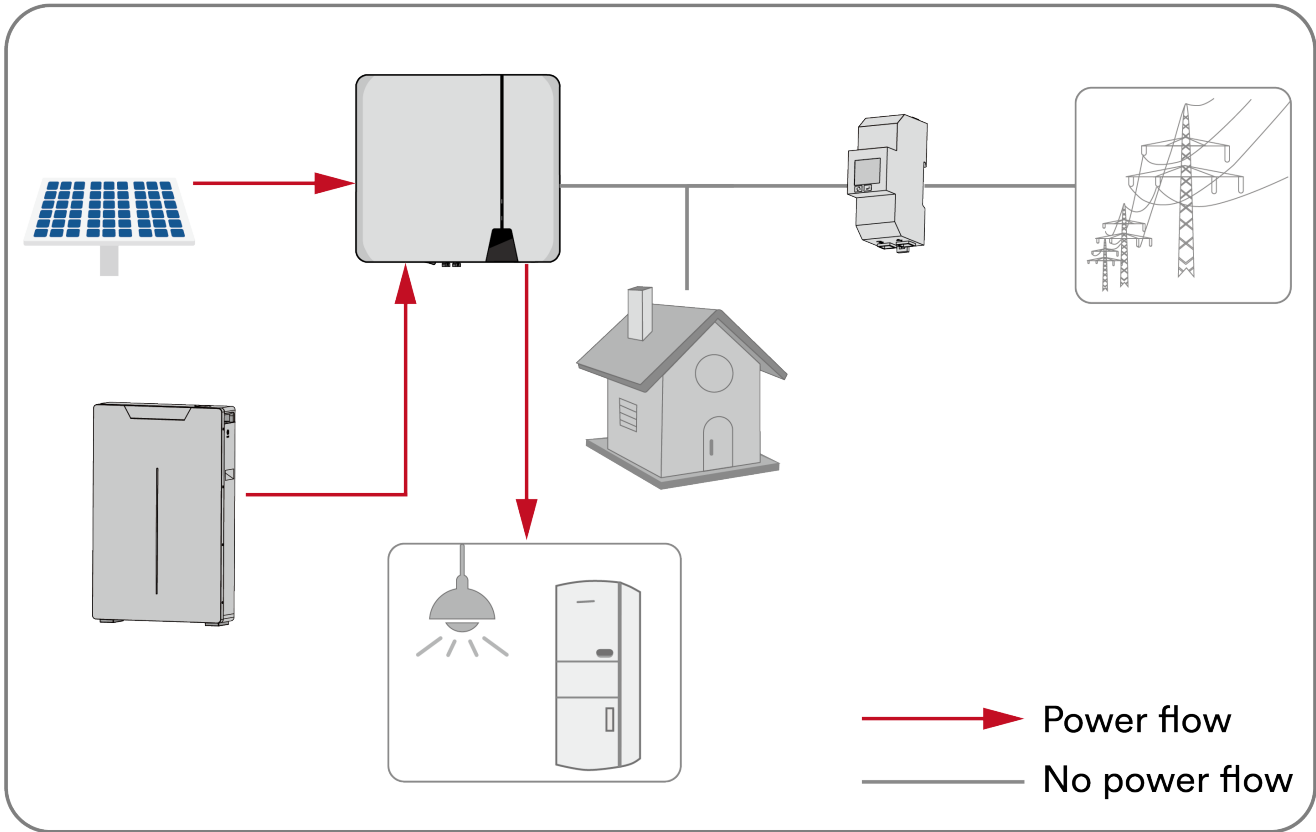

4.7.3 Force time use custom

Users can manage the energy according to their own needs, and set the daily regular charging and discharging on the app. Other time follow the Self-Consumption mode.

This mode requires WiFi stick to connect to the network normally in order to function properly.

4.7.4 Off-grid mode

If the power grid is too weak and the inverter operating unstably, it is recommended that the customer switch to off grid mode to achieve stable power supply.

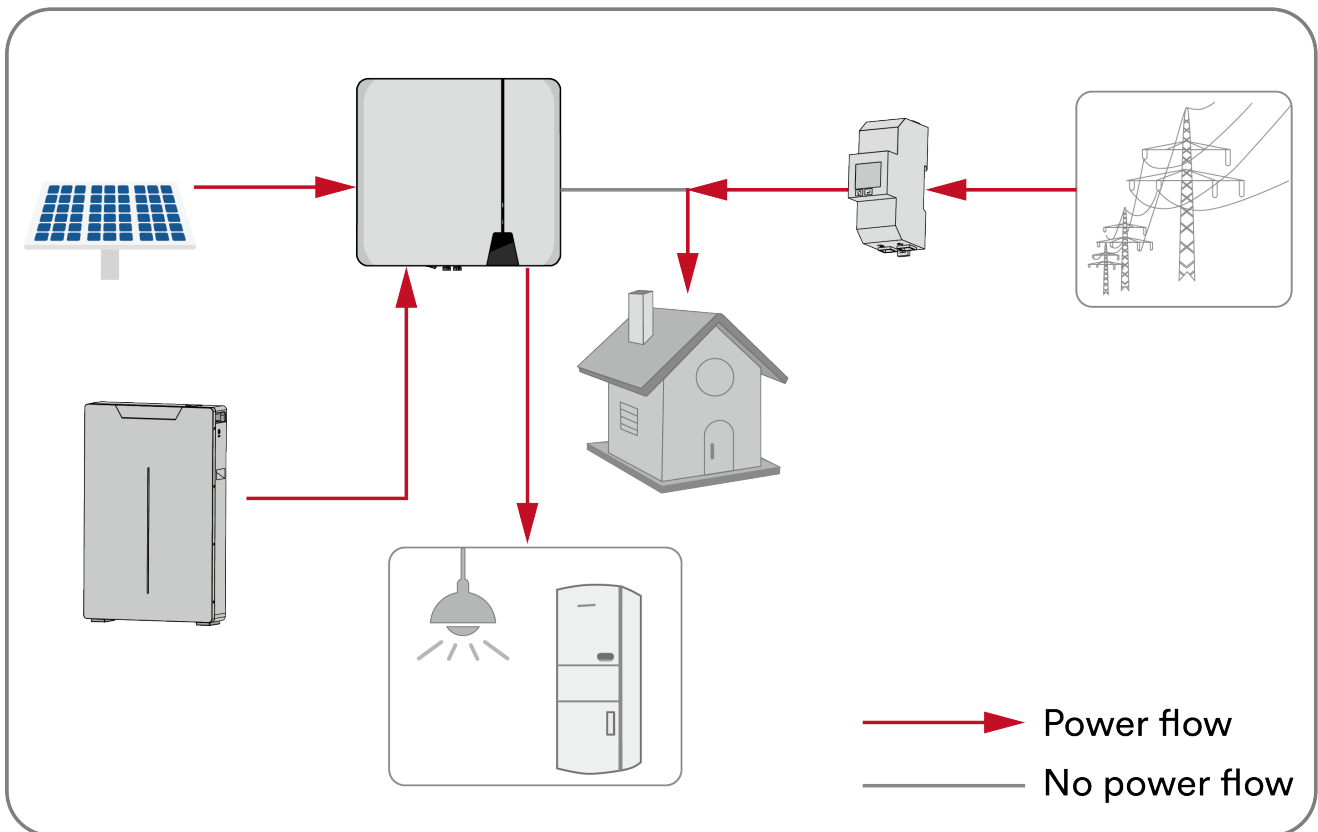

4.7.5 Time of use Mode

Let the inverter charge or discharge the battery to the set SOC value within the time period set by the app, and the battery discharge power in the grid-connected state can be customized.

Time of use mode reasonably sets the expected SOC of the battery according to the energy change of PV in the day, which helps the energy storage inverter to store the PV power to the battery with maximum efficiency, reduces the cost of buying electricity from the grid, and improves the cost performance of the energy storage inverter. This mode requires WiFi stick to connect to the network normally in order to function properly.

1. **Battery first:** PV power is firstly used to charge the battery and then used to power the load. If PV power is insufficient, grid will make supplement for battery and load simultaneously.
2. **Load first:** PV power is firstly used to power the load and then used to charge the battery. If PV power is insufficient, grid will make supplement for battery and load simultaneously.
3. **Grid Charge:** utilize grid to charge the battery in a time period.
4. **Power:** The maximum allow-able discharge power of the battery when connected to the grid.
5. **Battery (SOC %):** battery SOC % at when the action is to happen.

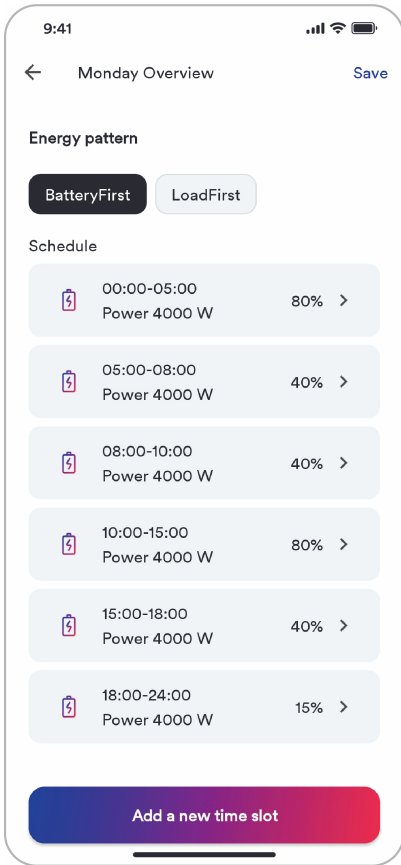

1

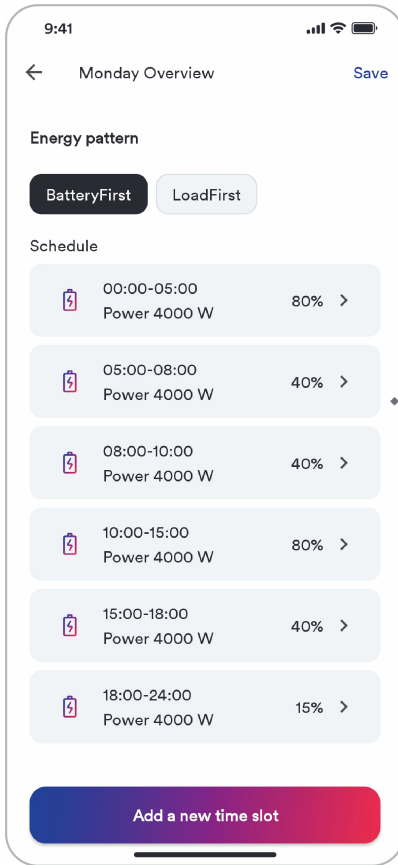

2

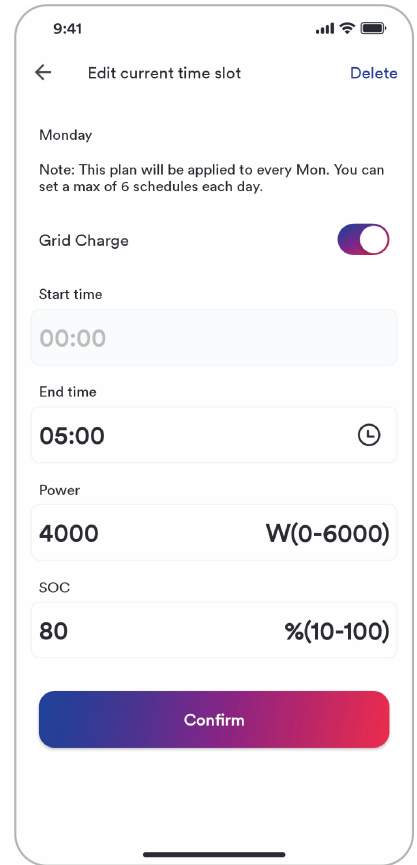

3

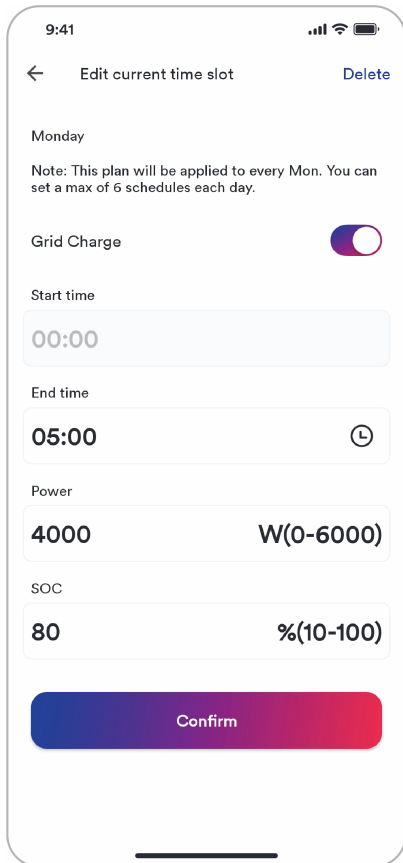

4

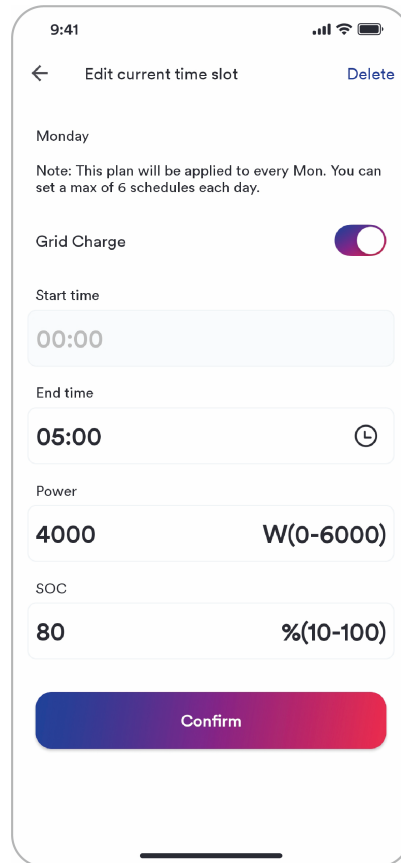

5

For example

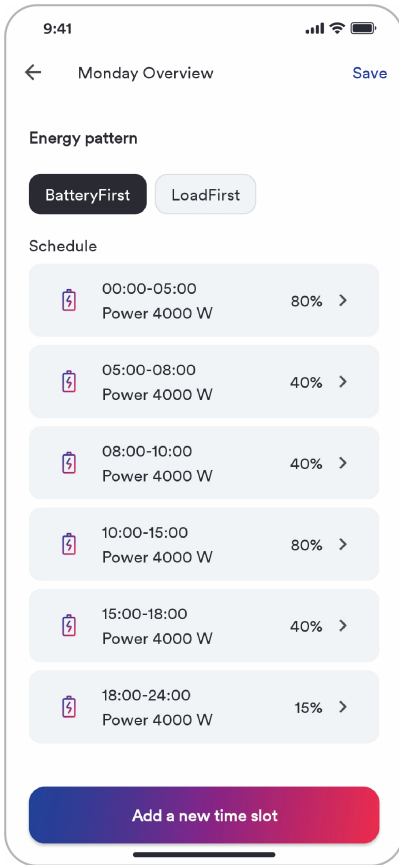

1

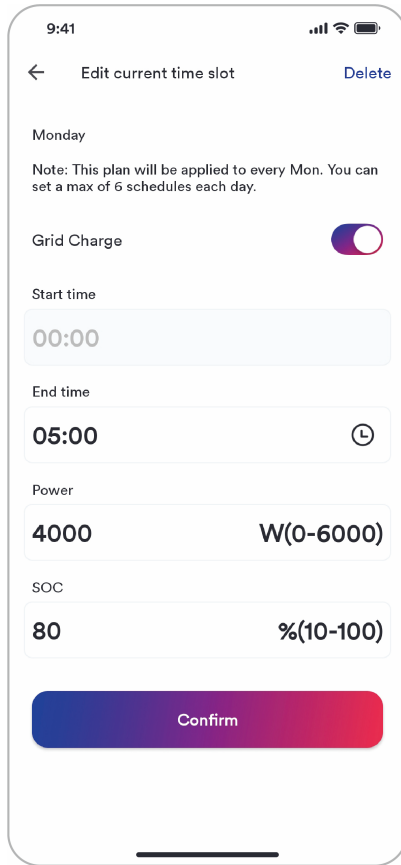

2

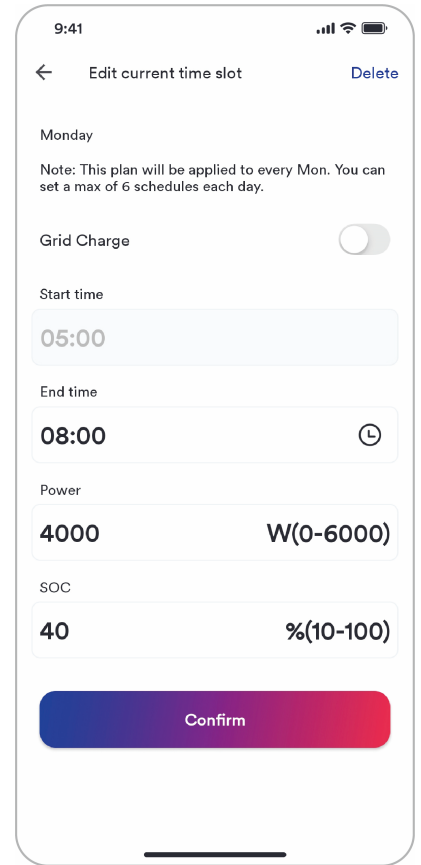

3

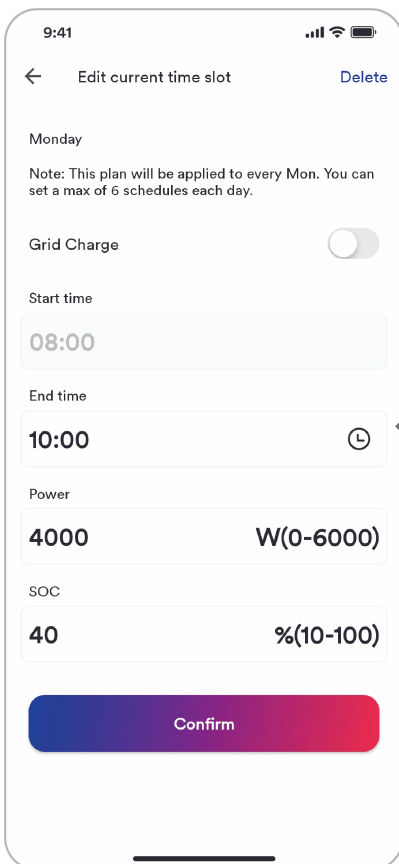

4

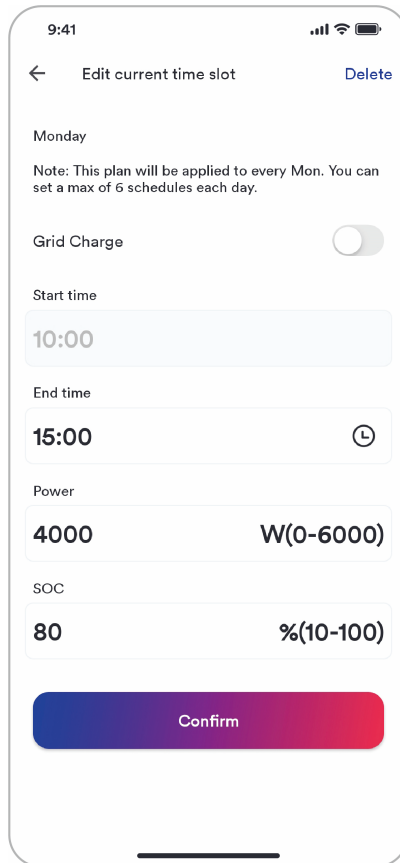

5

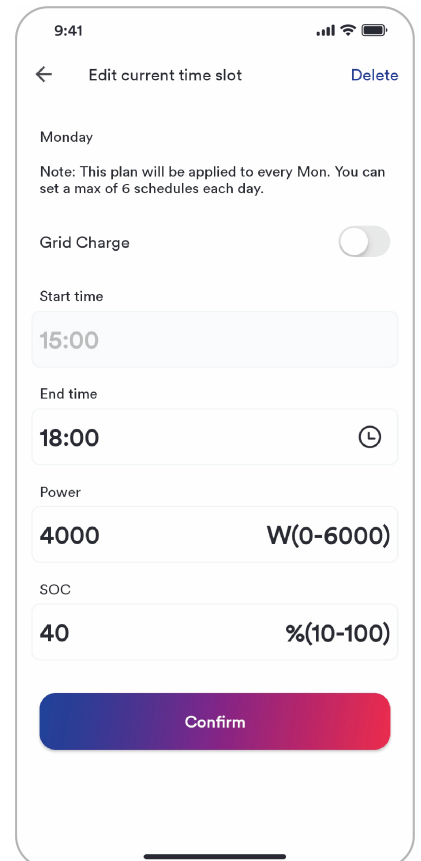

6

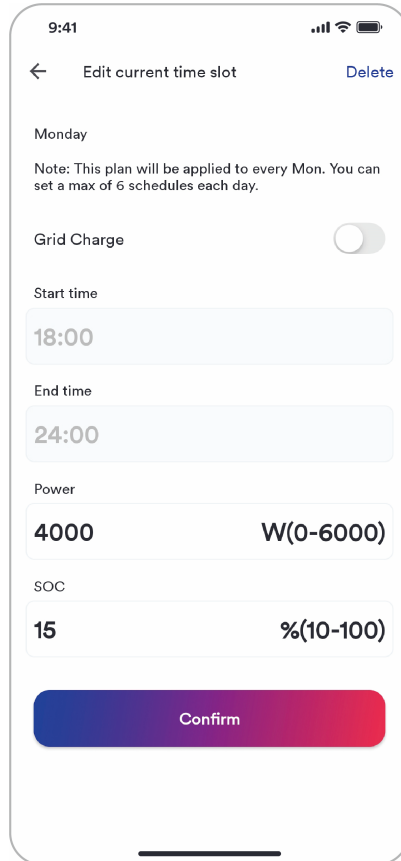

7

2: During 00:00-05:00, when battery SOC is lower than 80%, it will use grid to charge the battery until battery soc reaches 80%.

3-4: During 05:00-08:00 and 08:00-10:00, when battery SOC is higher than 40%, hybrid inverter will discharge the battery until the Soc reaches 40%.

5: During 10:00-15:00, when battery SOC is higher than 80%, hybrid inverter will discharge the battery until the SOC reaches 80%.

6: During 15:00-18:00, when battery SOC is higher than 40%, hybrid inverter will discharge the battery until the SOC reaches 40%.

7: During 18:00-00:00, when battery SOC is higher than 35%, hybrid inverter will discharge the battery until the SOC reaches 35%.

5 Mounting

5.1 Requirements for mounting

DANGER

Danger to life due to fire or explosion!

Despite careful construction, electrical devices can cause fires. This can result in death or serious injury.

- Do not mount the product in areas containing highly flammable materials or gases.
 - Do not mount the inverter in areas where there is a risk of explosion.
-
- The ambient temperature is recommended below 40°C to ensure optimal operation.
 - A solid support surface must be available (e.g., concrete or masonry). Ensure that the installation surface is solid enough to bear four times the weight. When mounted on drywall or similar materials, the product emits audible vibrations during operation which could be perceived as annoying.
 - The mounting location must be inaccessible to children.
 - The mounting location should be freely and safely accessible at all times without the need for any auxiliary equipment (such as scaffolding or lifting platforms). Non-fulfillment of these criteria may restrict servicing.
 - The mounting location must not be exposed to direct solar irradiation. If the product is exposed to direct solar irradiation, the exterior plastic parts might age prematurely and overheating might occur. When becoming too hot, the product reduces its power output to avoid overheating.

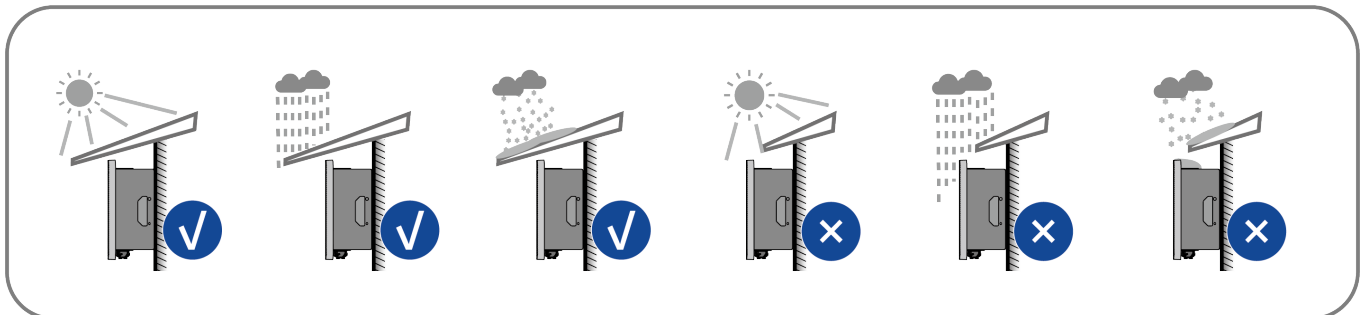

- Never install the inverter horizontally, or with a forward / backward tilt or even upside down. The horizontal installation can result in damage to the inverter.

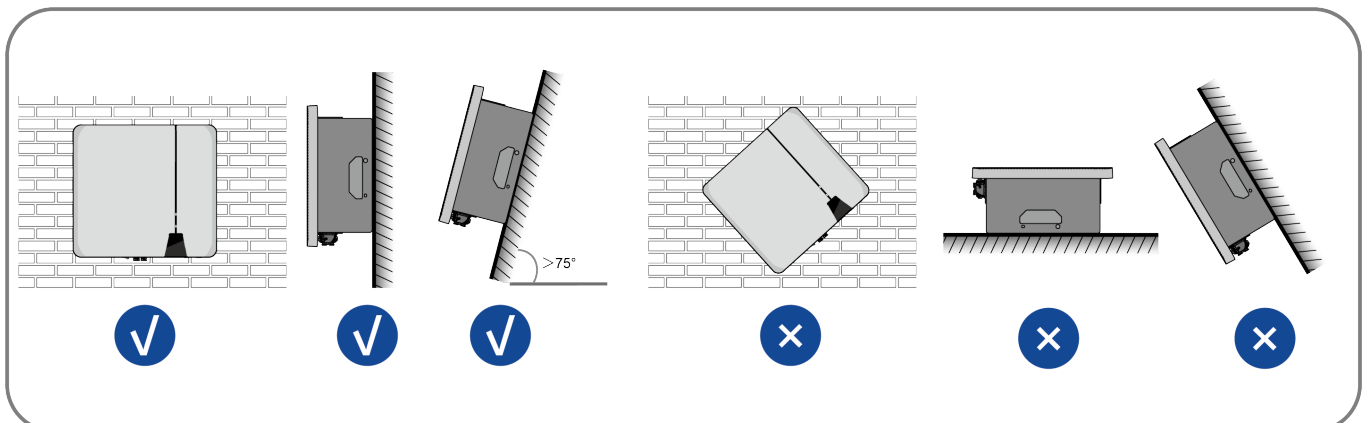

Maintain the recommended clearances to wall as well as to other inverters or objects.

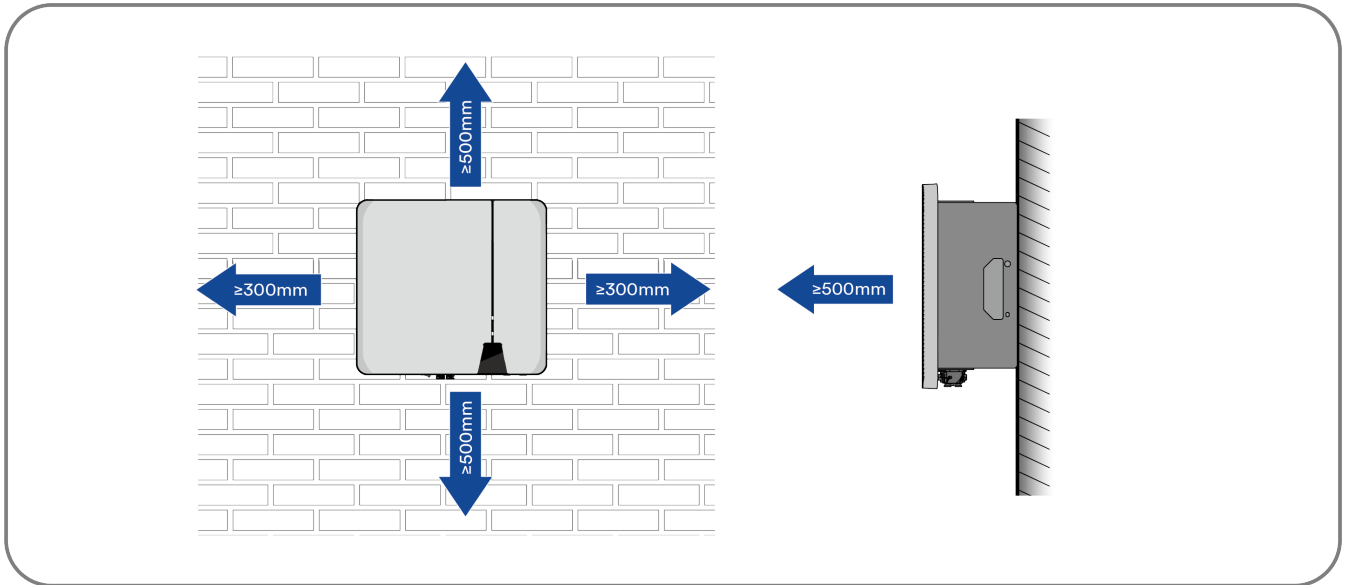

- In case of multiple inverters, reserve specific clearance between the inverters.

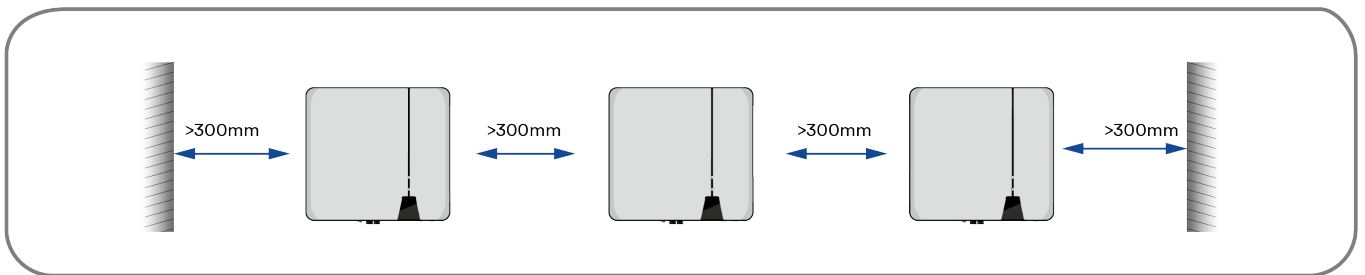

The product should be mounted such that the LED signals can be read off without difficulty.

The DC load-break switch of the product must always be freely accessible.

5.2 Taking out and moving the product

Open the inverter packaging box, take the inverter out of the packaging box, and place the inverter at the designated installation location.

CAUTION

Risk of injury due to the weight of the product!

The net weight of this product is 26kg. If the inverter is lifted incorrectly during the installation, it may fall down and cause injury or equipment damage.

- Transport and lift the product carefully. Take the weight of the product into account.
- Wear suitable personal protective equipment for all work on the product.

5.3 Mounting

Step 1: Align the mounting-bracket horizontally on the wall with the arrow upwards. Mark the position of the drill hole. Set the wall mounting bracket aside and drill the marked holes with the diameter of 10mm. The depth of the holes should be about 70 mm. Keep the hammer drill bit perpendicular to the wall to avoid drilling inclined.

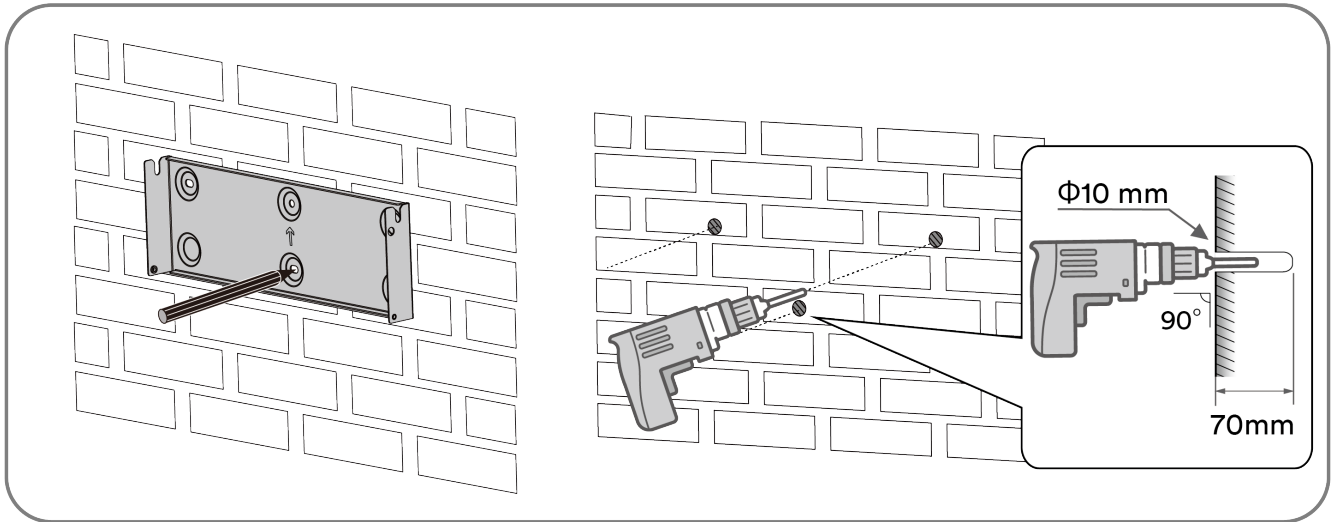

Step 2: Hammer the plastic expansion pipe slowly into the drilled hole.

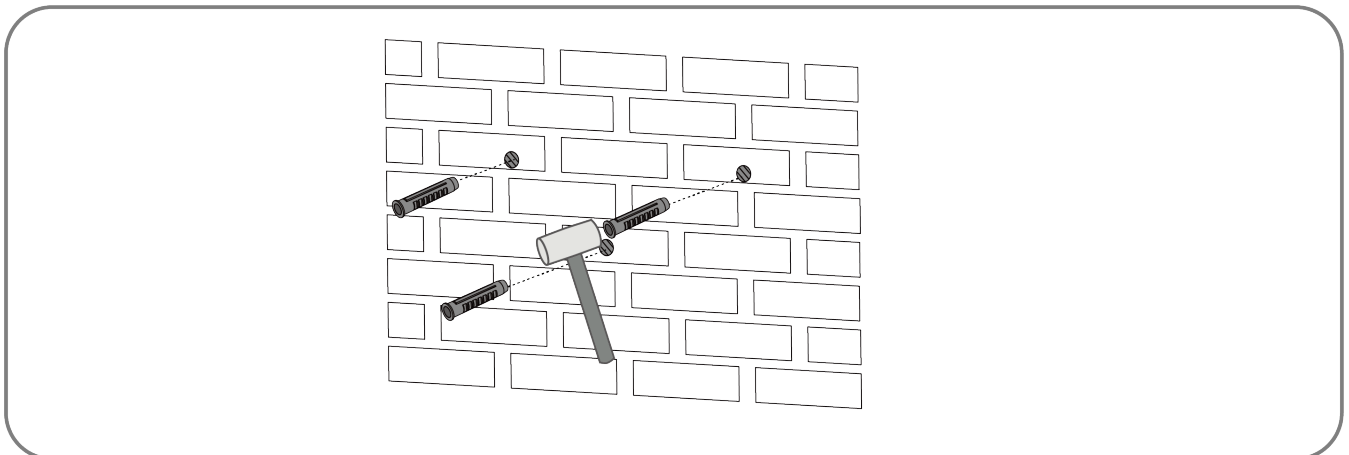

Step 3: Align the mounting-bracket with the hole position and use the tapping nail to fix the hanging plate.

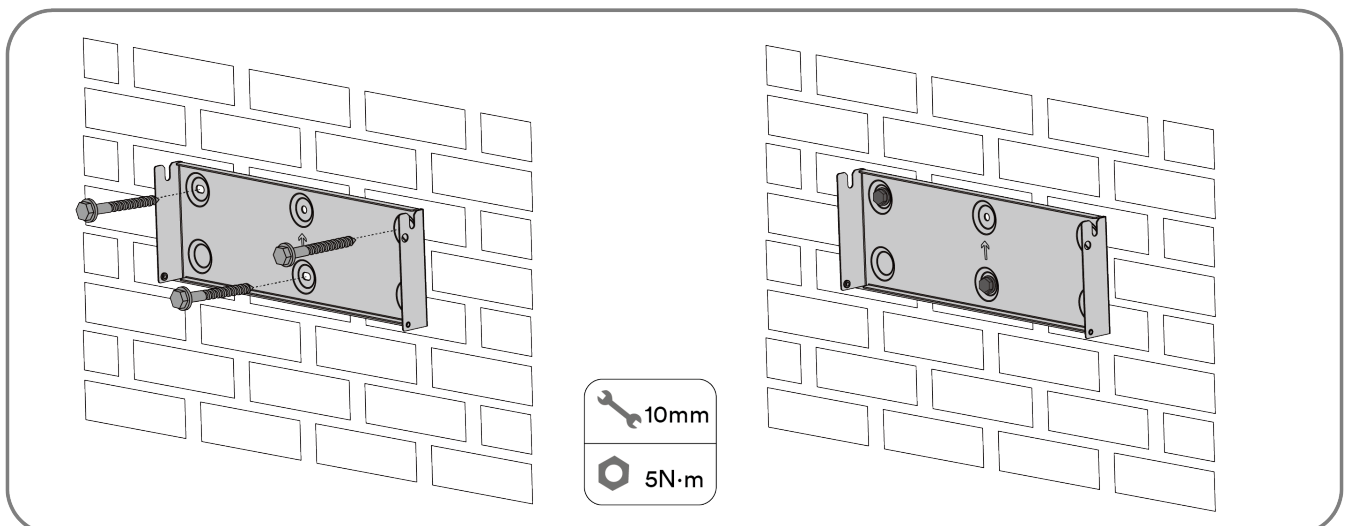

Step 4: Hang the inverter to the mounting-bracket and ensure that the mounting ears perfectly engage with the mounting-bracket.

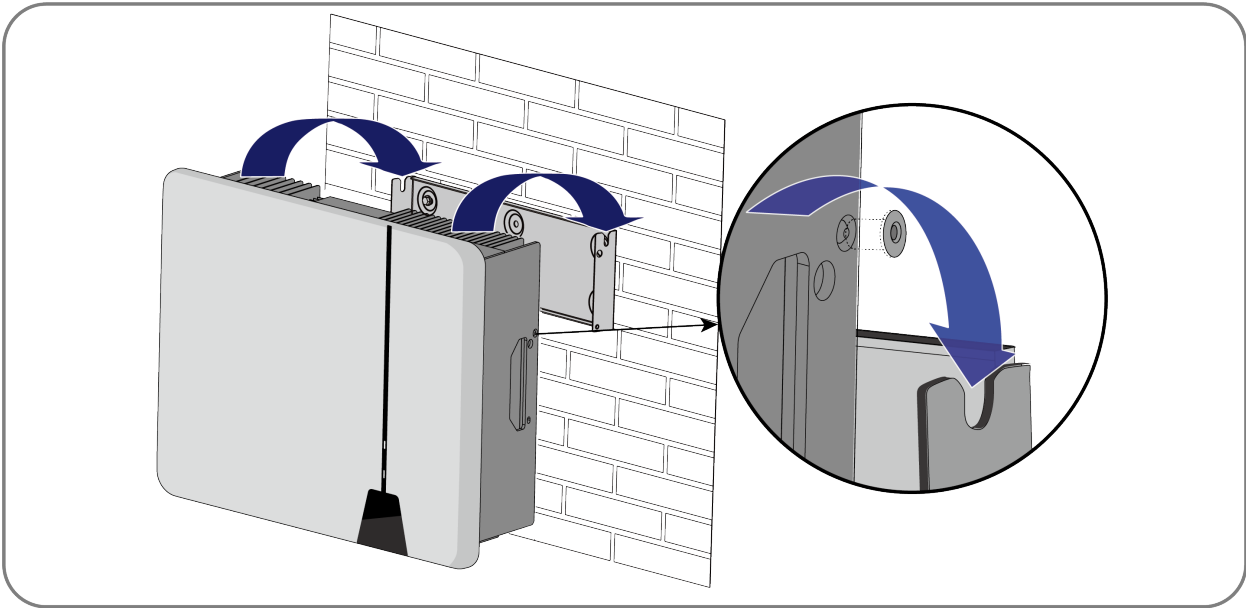

Step 5: Fix the inverter with screws.

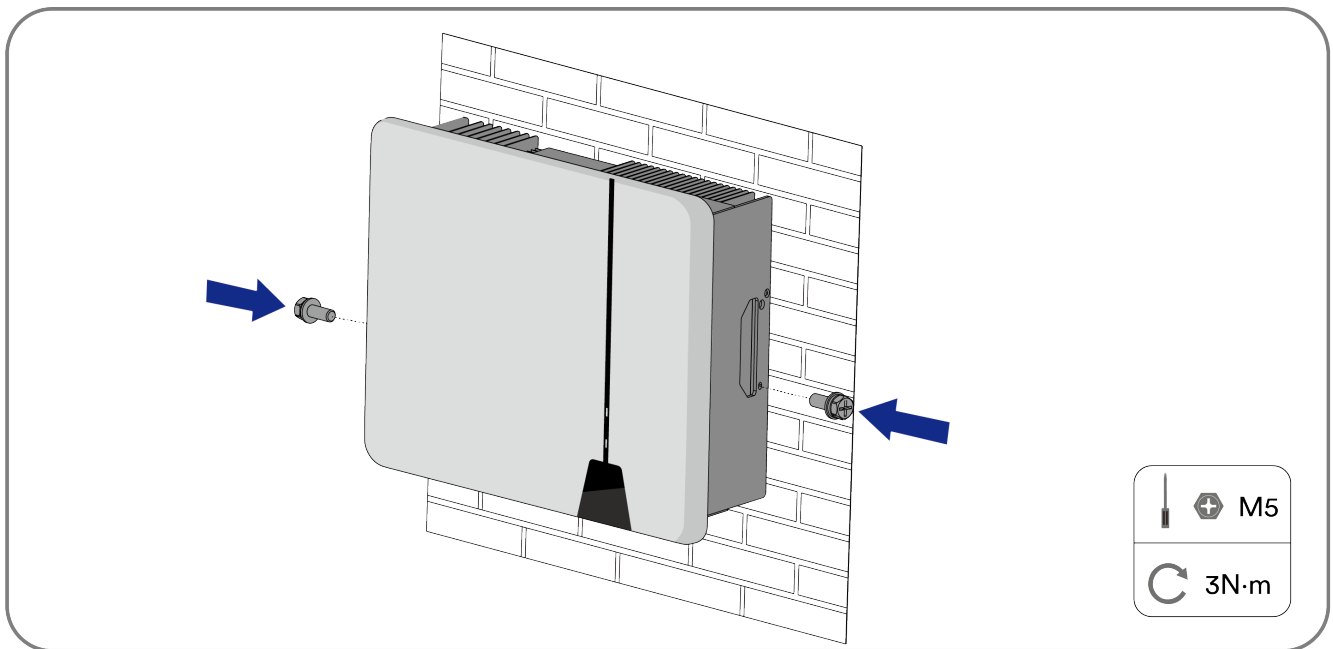

Step 6: To protect the inverter from theft, attach the padlock provided by customer through the wall mounting bracket and the inverter.

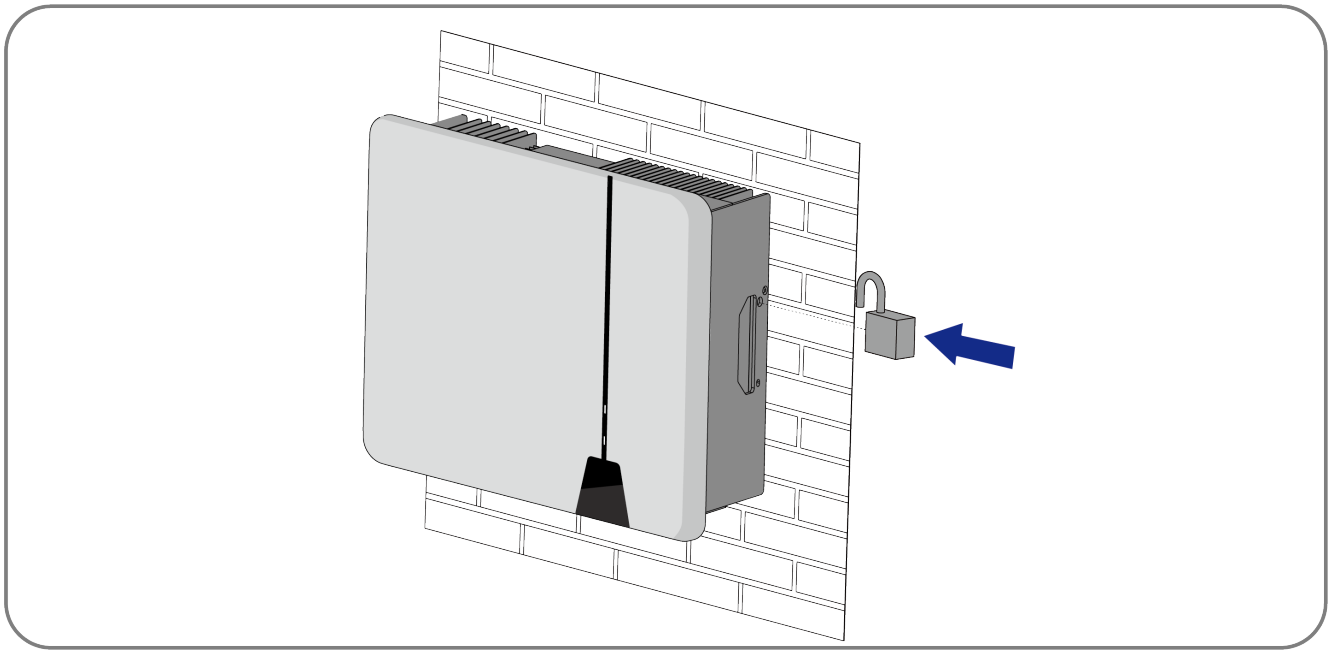

Complete the installation.

6 Electrical connection

6.1 Connection port description

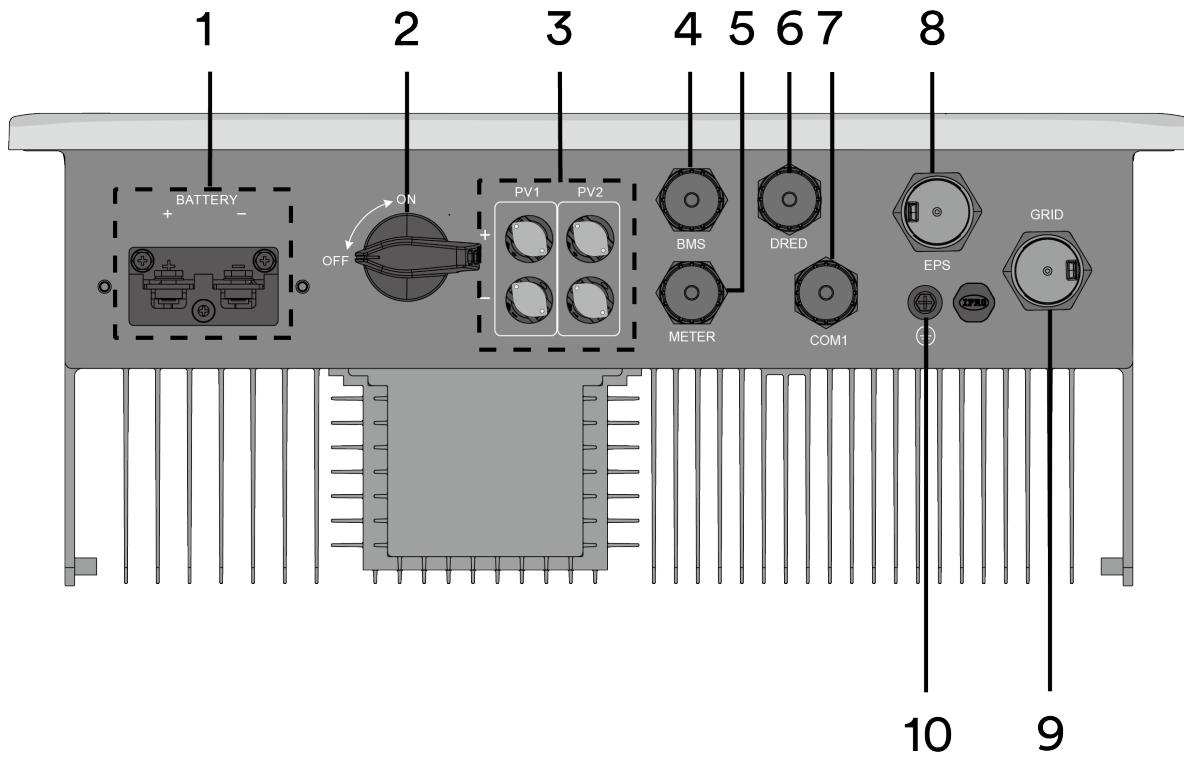

Figure shown here is for reference only. The actual product received may differ!

Object	Description
1	Battery terminal cover
2	DC-switch
3	PV Input
4	BMS: BMS communication port
5	METER: Merter communication port
6	DRED: DRM's device port
7	Communication device (Wi-Fi Stick)
8	EPS connector
9	AC connector
10	Additional grounding screw

6.2 Connecting additional grounding

The inverter is equipped with a grounding conductor monitoring device. This grounding conductor monitoring device detects when there is no grounding conductor connected and disconnects the inverter from the utility grid if this is the case. Hence the product does not require an additional grounding or equipotential bonding when operating.

If the grounding conductor monitoring function is deactivated or the additional grounding is required by locally standard, you can connect additional grounding to the inverter.

Requirements for the secondary protection ground cable:

Item	Description	Note
1	Screw	Specifications M5, complimentary
2	OT/DT terminal	Specifications M5, complimentary
3	Yellow and green ground cable	Same as the PE wire in the AC cable.

Procedure:

Step 1: Strip the grounding cable insulation. Insert the stripped part of the grounding cable into the ring terminal lug and crimp using a crimping tool.

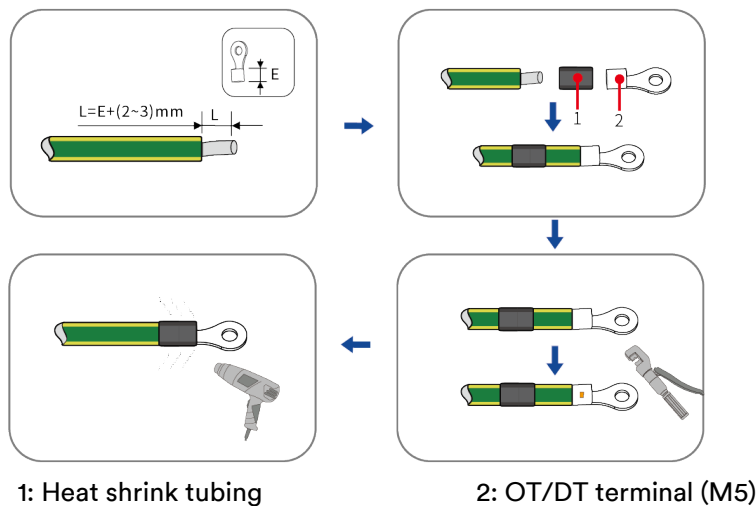

Step 2: Remove the screw on the ground terminal, insert the screw through the OT/DT terminal, and lock the terminal using a wrench.

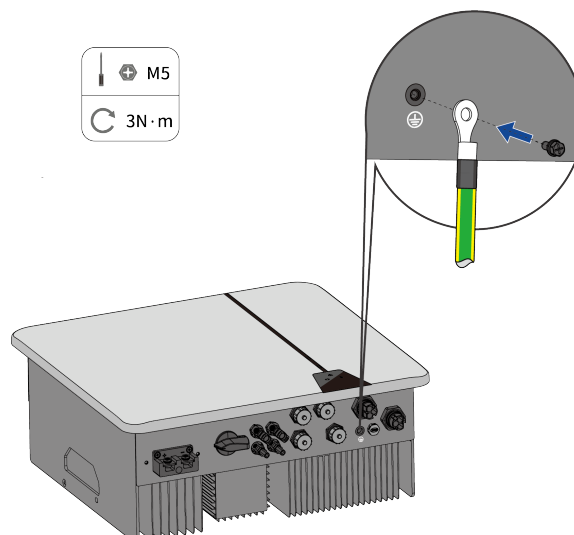

Step 3: Apply paint to the grounding terminal to ensure corrosion resistance.

Complete the installation.

6.3 Grid cable connection

6.3.1 Requirements for the Grid connection

Cable Requirements

The cable must be dimensioned in accordance with the local and national directives for the dimensioning of cables. The requirements for the minimum wire size derive from these directives. Examples of factors influencing cable dimensioning are: nominal AC current, type of cable, routing method, cable bundling, ambient temperature and maximum desired line losses.

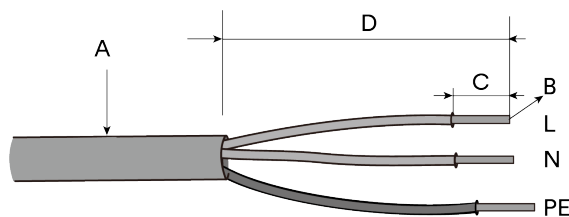

Item	Description	Value
A	External diameter	10-16 mm
B	Copper cable conductor cross-section	4~6 mm ²
C	Insulation stripping length	approx. 13 mm
D	Sheath stripping length	approx. 53 mm

Residual current protection

The product is equipped with an integrated universal current-sensitive residual current monitoring unit inside. Hence the product does not require an external residual-current device when operating.

If local regulations require the use of a residual-current device, please install a type A residual-current protection device with a protection limit of not less than 300mA.

Overvoltage category

The inverter can be used in grids of overvoltage category III or lower in accordance with IEC 60664-1. That means that the product can be permanently connected to the grid-connection point of a building. In case of installations with long outdoor cable route, additional measures to reduce overvoltage category IV to overvoltage category III are required.

AC circuit breaker

In PV systems with multiple inverters, protect each inverter with a separate circuit breaker. This will prevent residual voltage being present at the corresponding cable after disconnection.

No consumer load should be applied between AC circuit breaker and the inverter.

The selection of the AC circuit breaker rating depends on the wiring design (wire cross-section area), cable type, wiring method, ambient temperature, inverter current rating, etc. Derating of the AC circuit breaker rating may be necessary due to self-heating or if exposed to heat.

The maximum output current and the maximum output overcurrent protection of the inverters can be found in section 10 “Technical data”.

Grounding conductor monitoring

The inverter is equipped with a grounding conductor monitoring device. This grounding conductor monitoring device detects when there is no grounding conductor connected and disconnects the inverter from the utility grid if this is the case. Depending on the installation site and grid configuration, it may be advisable to deactivate the grounding conductor monitoring. This is necessary, for example, in an IT system if there is no neutral conductor present and you intend to install the inverter between two line conductors. If you are uncertain about this, contact your grid operator or AISWEI.



Safety in accordance with IEC 62109 when the grounding conductor monitoring is deactivated.

In order to guarantee safety in accordance with IEC 62109 when the grounding conductor monitoring is deactivated, carry out the following measure.

- Connect an additional grounding that has at least the same cross-section as the connected grounding conductor to the AC cable. This prevents touch current in the event of the grounding conductor on the AC cable failing.

6.3.2 Assembling the grid connectors

Step 1: Switch off the miniature circuit-breaker or the switch of every energy sources and secure it against being inadvertently switched back on.

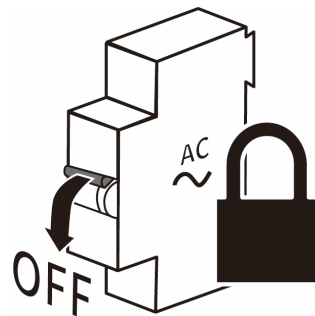

Step 2: Split grid connector.

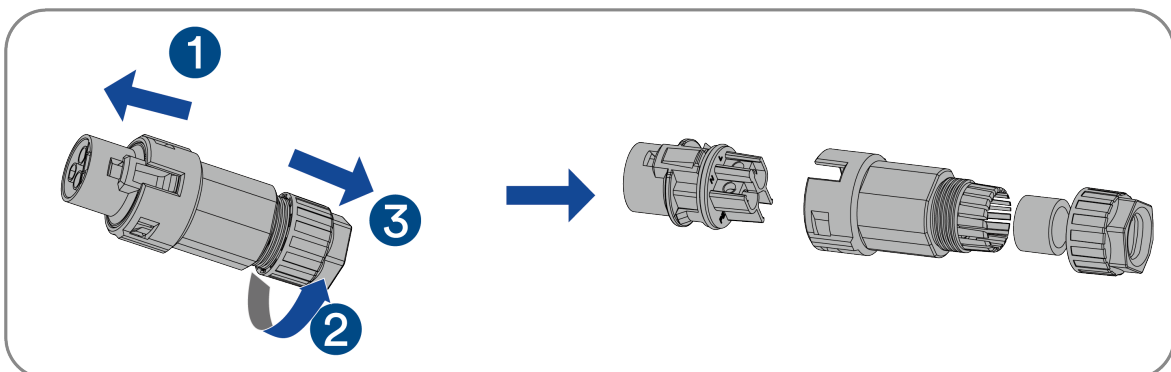

Step 3: Crimp the terminals with crimping pliers.

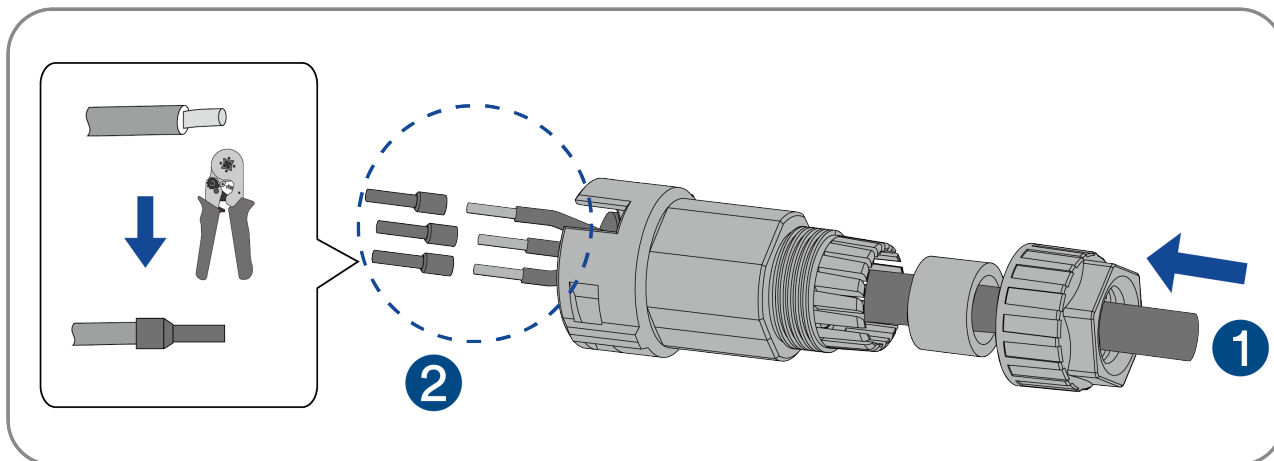

Step 4: Set the parts on the cable, insert the terminal holes in sequence. Crimp the wire with an inner hexagon screwdriver and screw the torque $1.2 \pm 0.1 \text{ N}\cdot\text{m}$.

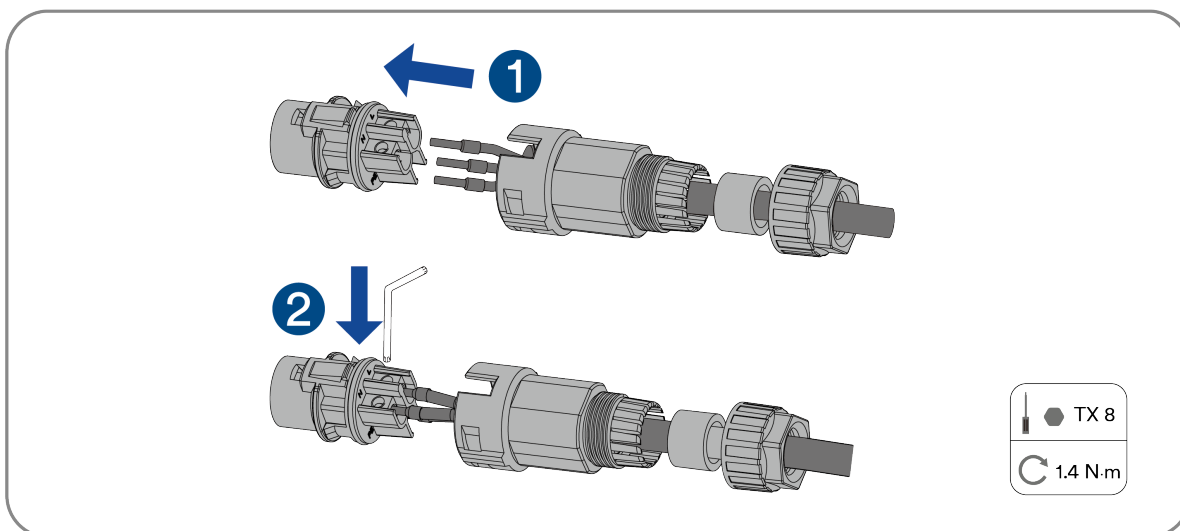

Step 5: Insert the main body into the rubber core and hear the “click” sound. Tighten the nut with an open-ended wrench (torque $2.5 \pm 0.5 \text{ N}\cdot\text{m}$).

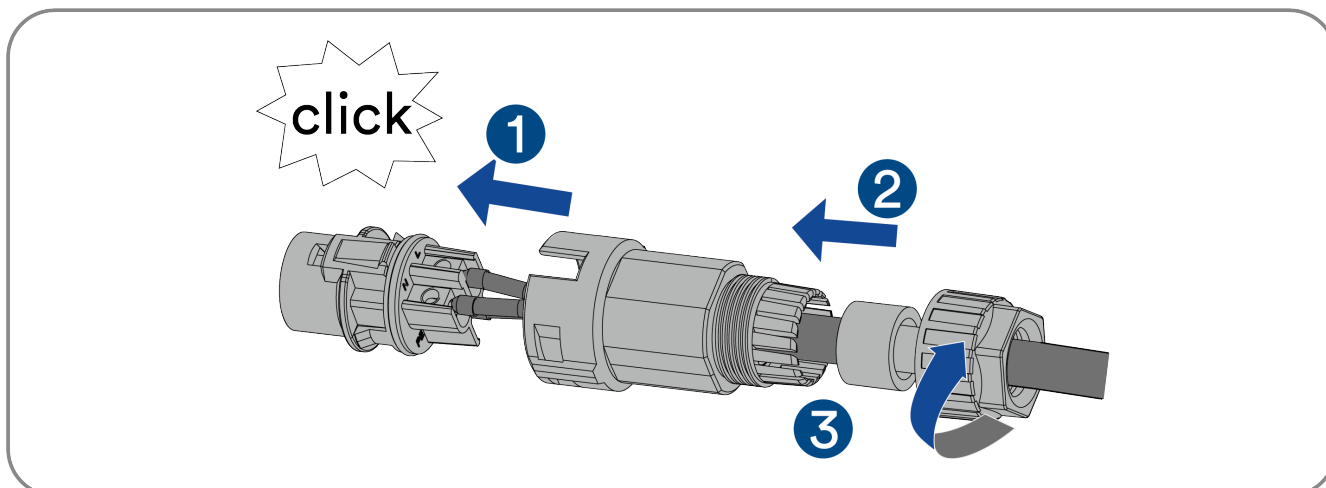

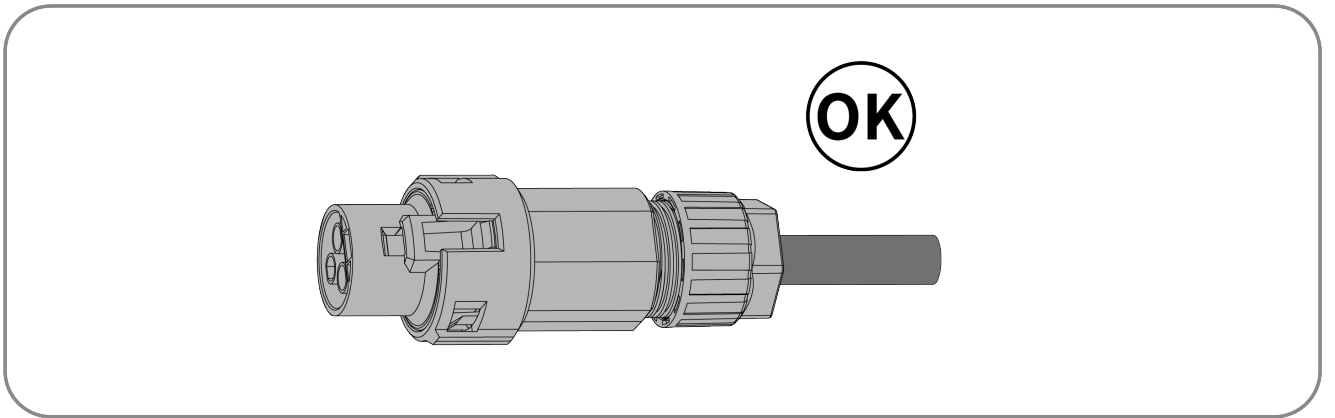

6.3.3 Connecting the grid connectors

Step 1: Remove the dust cover.

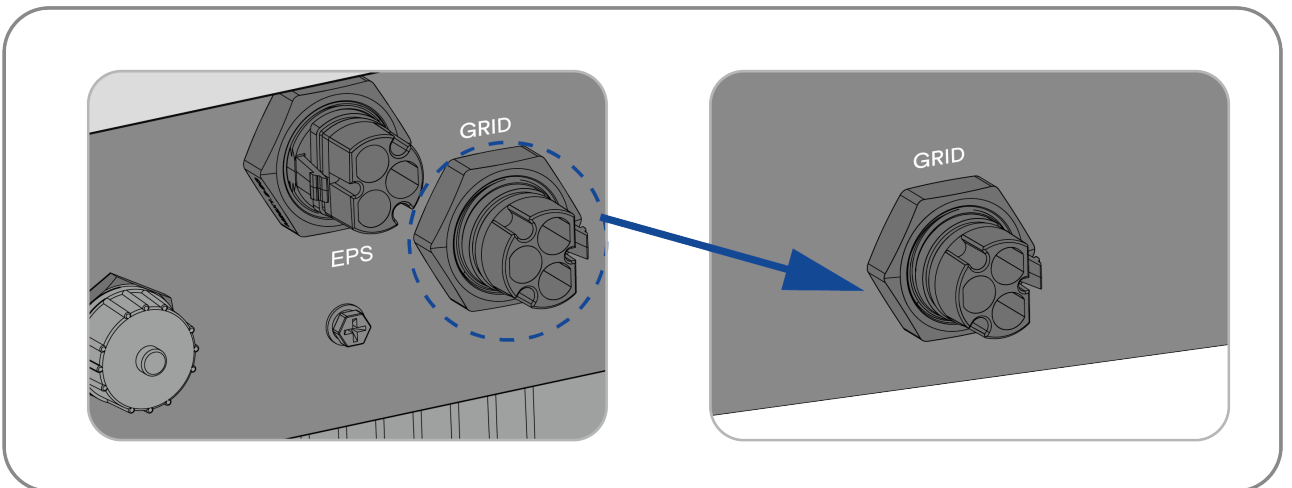

Step 2: The installation arrow indicates insertion the female connector, and hear the “click” sound.

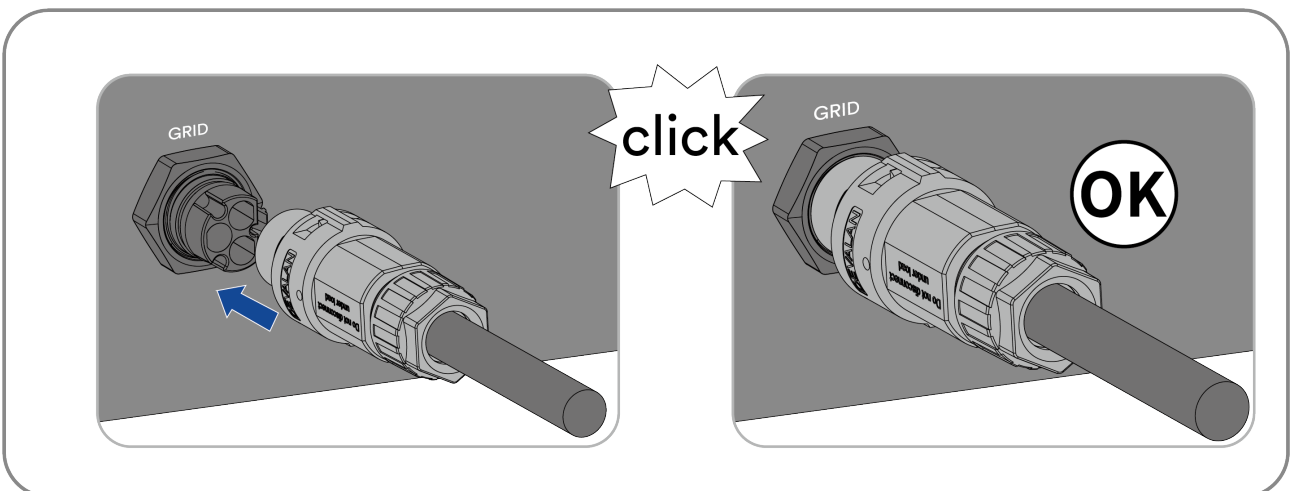

Complete the installation.

6.4 EPS Load cable connection

6.4.1 Requirements for the EPS Load connection

For EPS Load connection requirements, refer to “6.3.1 Requirements for the Grid connection” for details.

6.4.2 Assembling the EPS Load connectors

Step 1: Switch off the miniature circuit-breaker or the switch of every energy sources and secure it against being inadvertently switched back on.

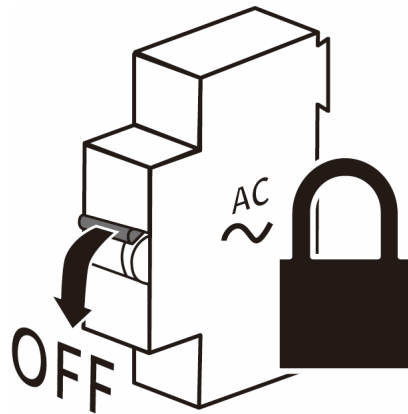

Step 2: Split grid connector.

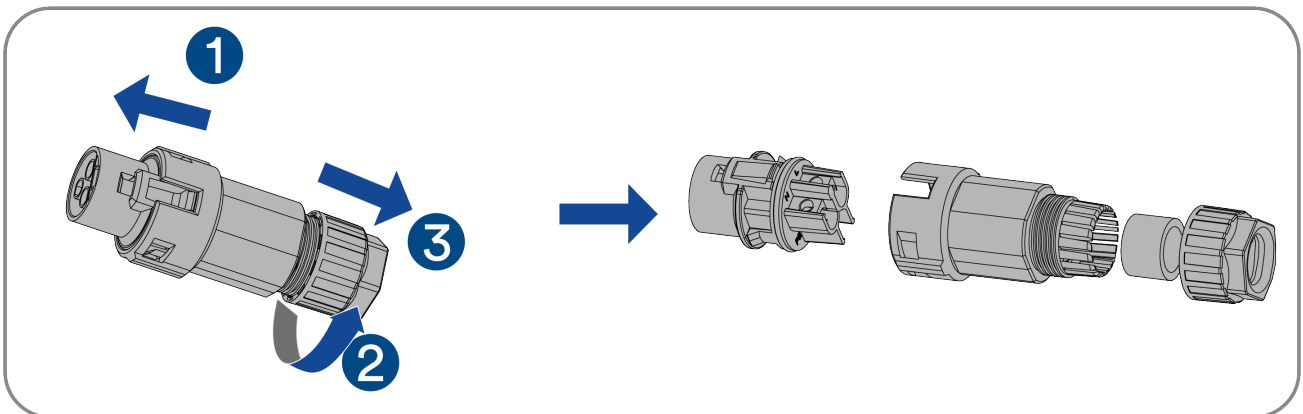

Step 3: Crimp the terminals with crimping pliers.

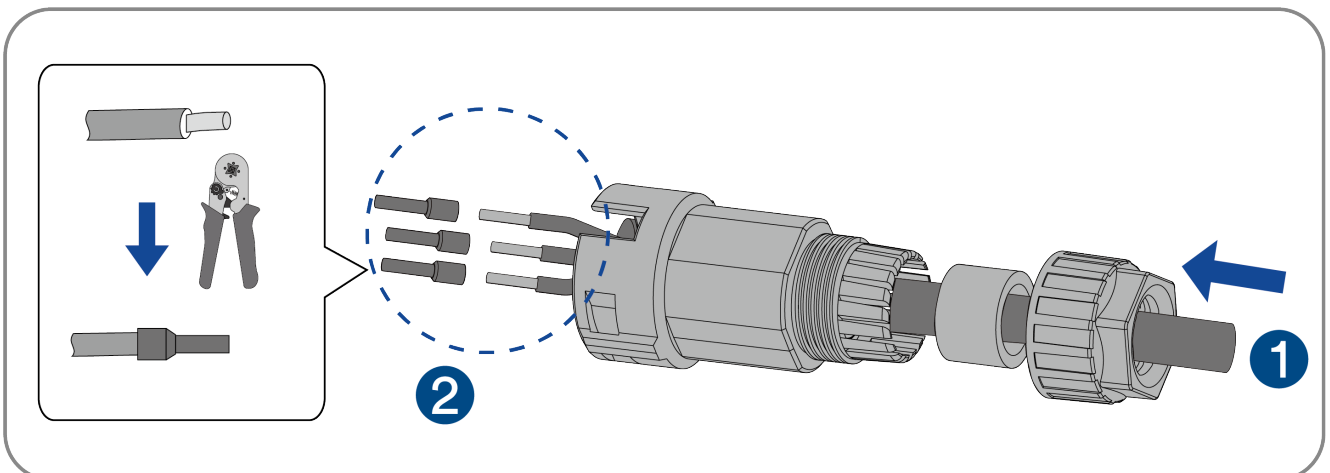

Step 4: Set the parts on the cable, insert the terminal holes in sequence. Crimp the wire with an inner hexagon screwdriver and screw the torque 1.2+/-0.1N·m.

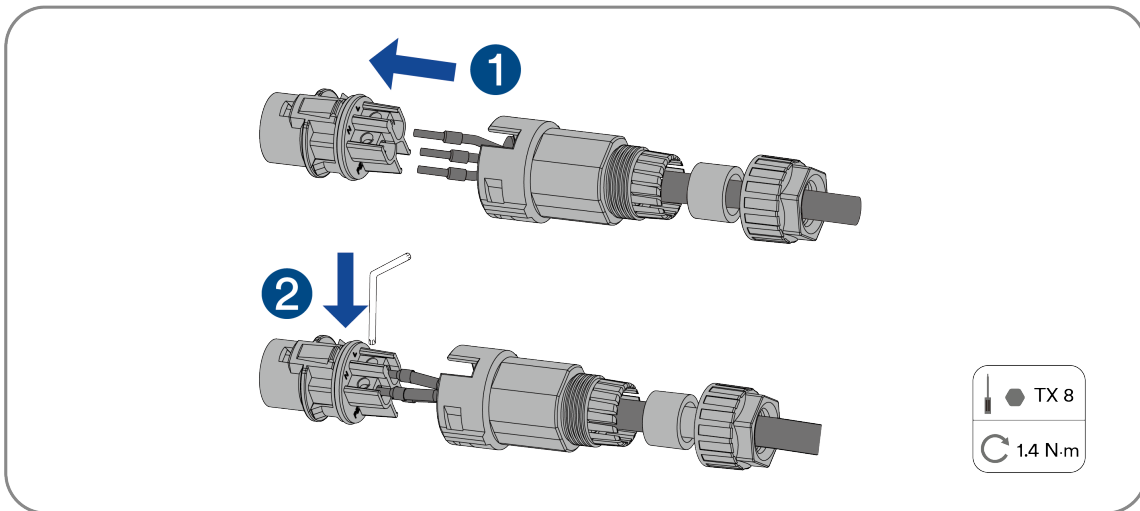

Step 5: Insert the main body into the rubber core and hear the “click” sound. Tighten the nut with an open-ended wrench (torque 2.5±0.5N·m).

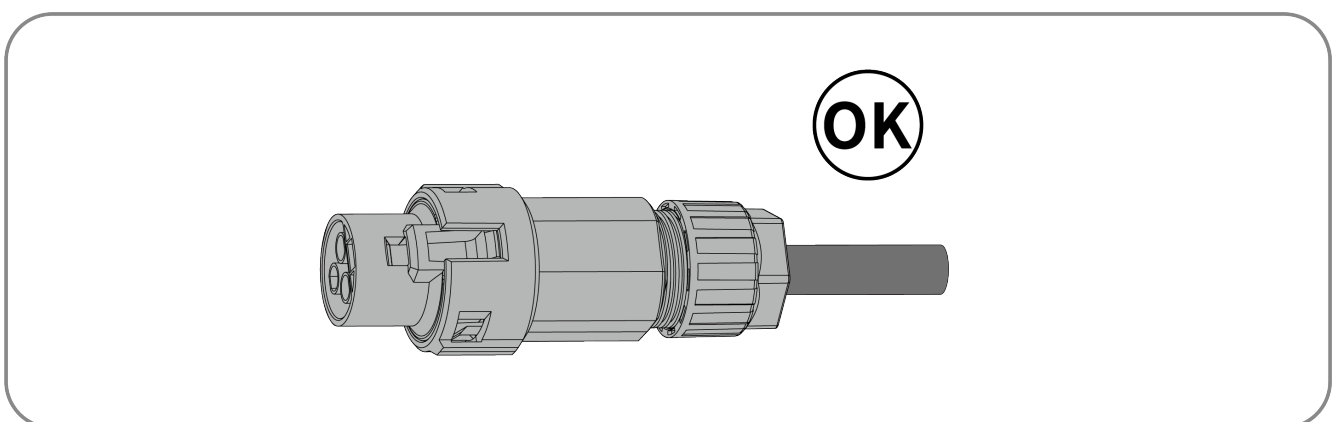
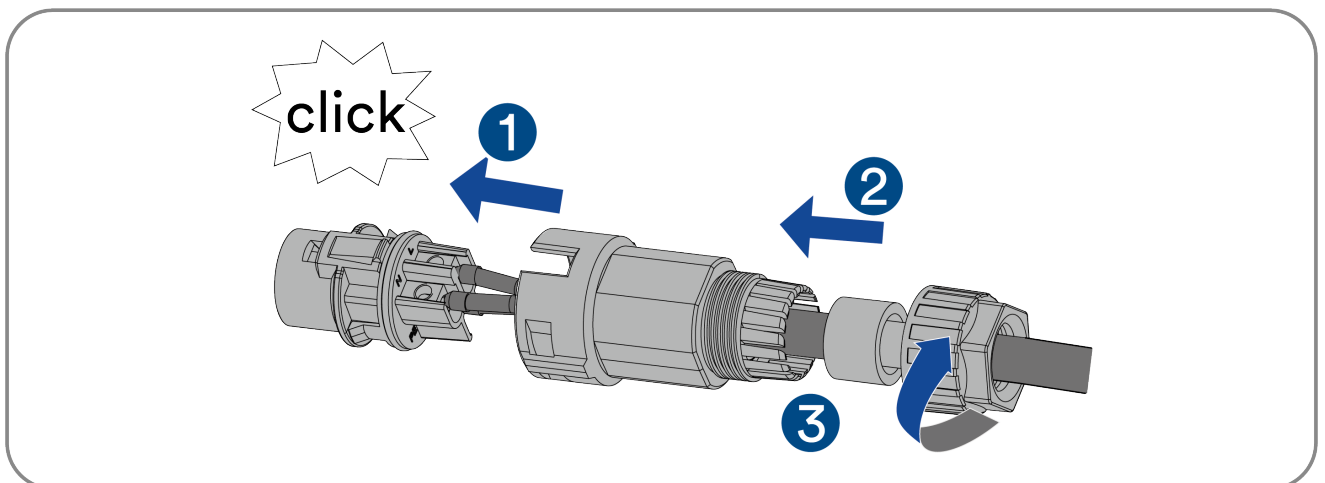

6.4.3 Connecting the Back Load connectors

Step 1: Remove the dust cover.

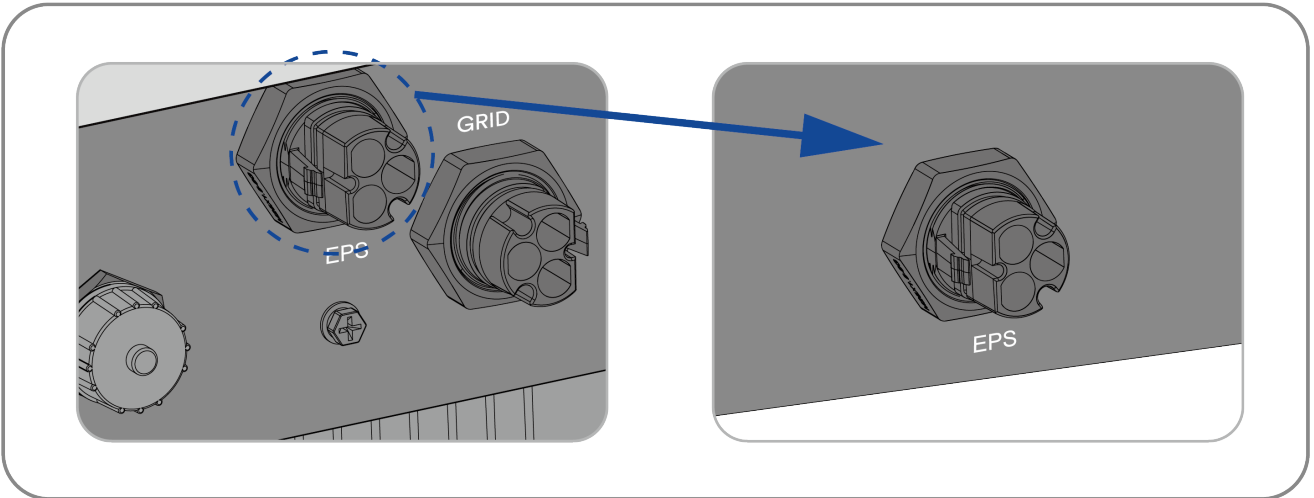

Step 2: The installation arrow indicates insertion the female connector, and hear the “click” sound.

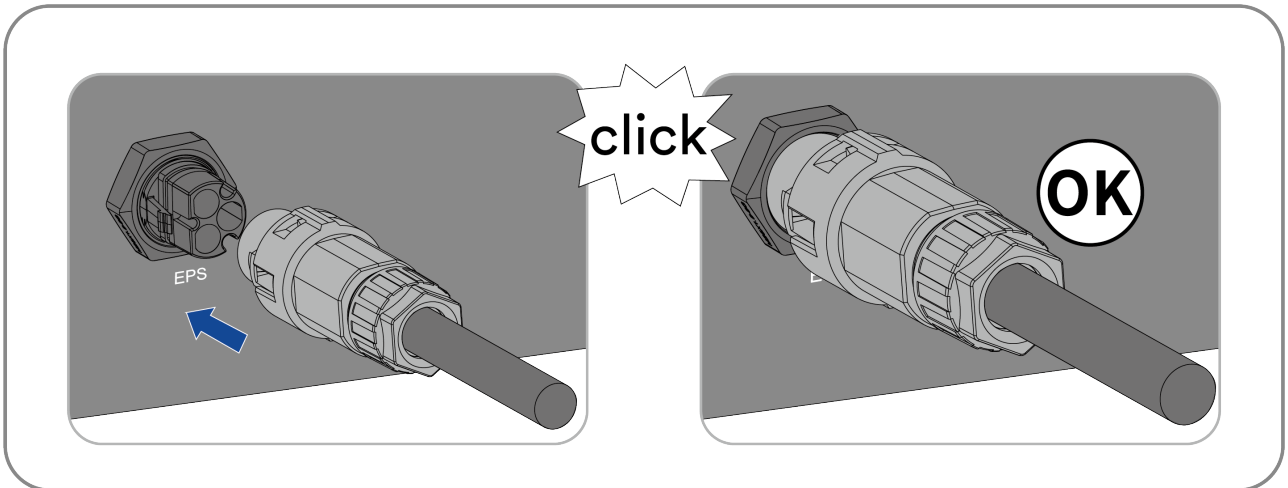

Complete the installation.

6.5 DC connection

6.5.1 Requirements for the DC connection

Requirements for the PV modules per input:

- All PV modules should be of the same type.
- All PV modules should be aligned and tilted identically.
- On the coldest day based on statistical records, the open-circuit voltage of the PV modules must never exceed the maximum input voltage of the inverter.
- The maximum input current per PV module must be maintained and must not exceed the through fault current of the DC connectors.
- The connection cables to the inverter must be equipped with the connectors included in the scope of delivery.

- The thresholds for the input voltage and the input current of the inverter must be adhered to.
- The positive connection cables of the PV modules must be equipped with the positive DC connectors. The negative connection cables of the PV modules must be equipped with the negative DC connectors.

6.5.2 Assembling the DC connectors

DANGER

Danger to life due to electric shock when live components or DC cables are touched!

When exposed to light, the PV modules generate high DC voltage which is present in the DC cables. Touching live DC cables results in death or lethal injuries due to electric shock.

- Do not touch non-insulated parts or cables.
- Disconnect the product from voltage sources and ensure it cannot be reconnected before working on the device.
- Wear suitable personal protective equipment for all work on the product.

i

For connection to the inverter, all PV module connection cable must be fitted with the DC connectors provided. There may be one of two different type DC connector shipped. Assemble the DC connectors as described in the following.

Type 1 DC connector:

Assemble the DC connectors as described below. Be sure to observe the correct polarity. The DC connectors are marked with the symbols “+” and “-”.

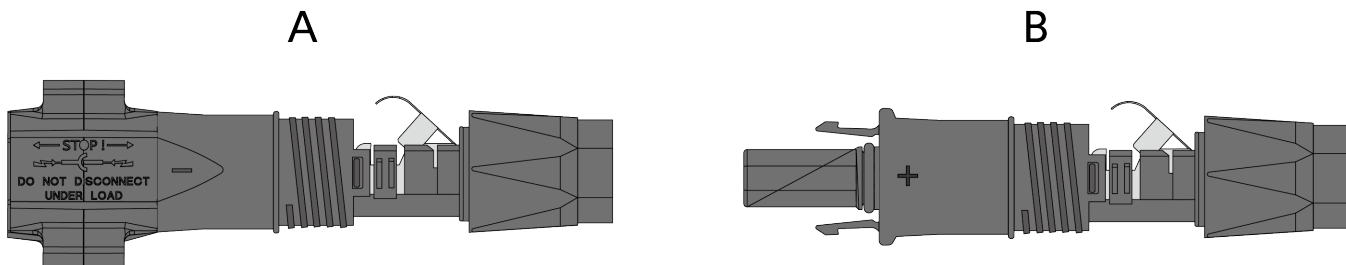

Cable requirements:

Item	Description	Value
1	Cable type	PV cable
2	External diameter	5-8 mm
3	Conductor cross-section	2.5-6 mm ²
4	Number of copper wires	At least 7
5	The rated voltage	≥1100v

Procedure:

Step 1: Strip 12 mm off the cable insulation.

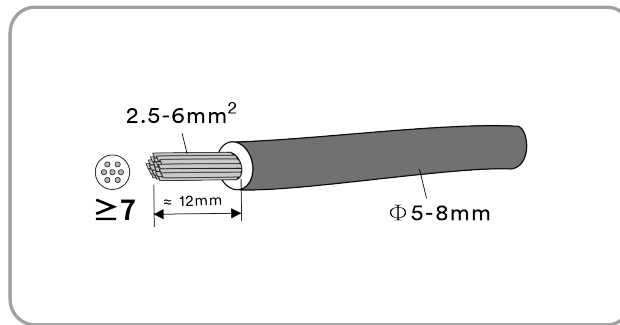

Step 2: Crimp the contacts with the corresponding cables. Crimping tool: PV-CZM-61100.

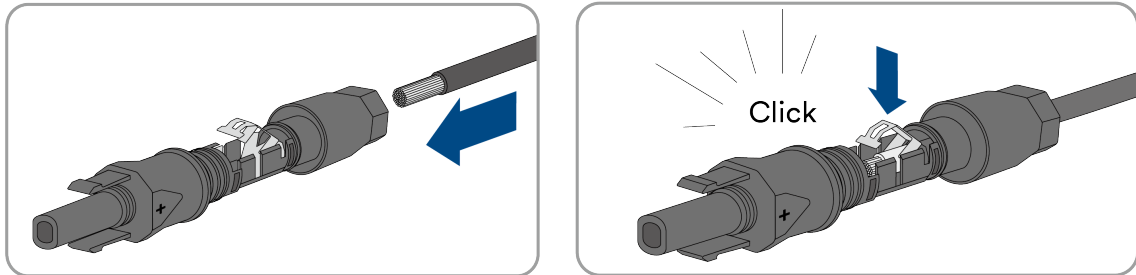

If the stranded wire is not visible in the chamber, the cable is not correctly inserted and the connector must be reassembled. To do this, the cable must be removed from the connector.

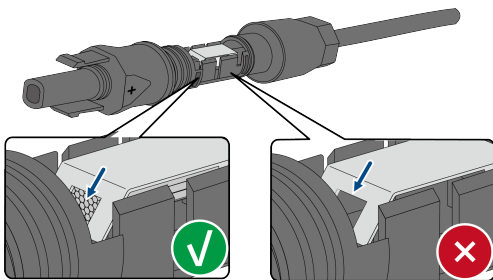

Release the clamping bracket. To do so, insert a screwdriver (blade width: 3.5mm) into the clamping bracket and pry the clamping bracket open.

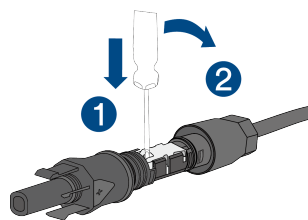

Remove the cable and go back to step 2.

Step 3: Push the swivel nut up to the thread and tighten the swivel nut. (SW15, Torque: 2.0Nm)

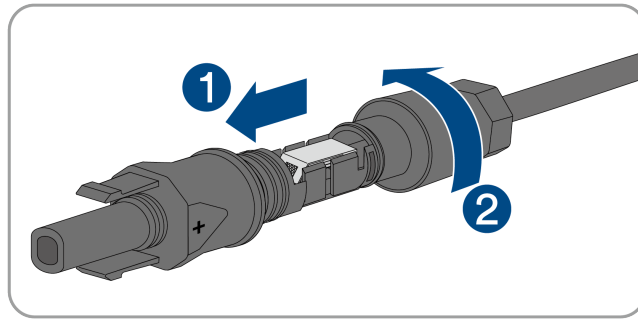

Type 2 DC connector:

Assemble the DC connectors as described in the following.

Assemble the DC connectors as described below. Be sure to observe the correct polarity. The DC connectors are marked with the symbols “+” and “-”.

A

B

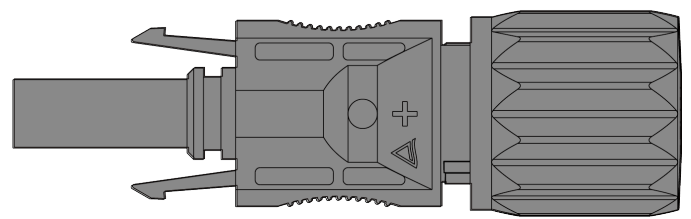
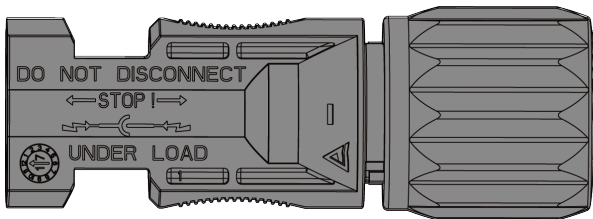

Cable requirements:

Item	Description	Value
1	Cable type	PV1-F, UL-ZKLA or USE2
2	External diameter	5-8 mm
3	Conductor cross-section	2.5-6 mm ²
4	Number of copper wires	At least 7
5	The rated voltage	≥1100v

Procedure:

Step 1: Strip 12 mm off the cable insulation.

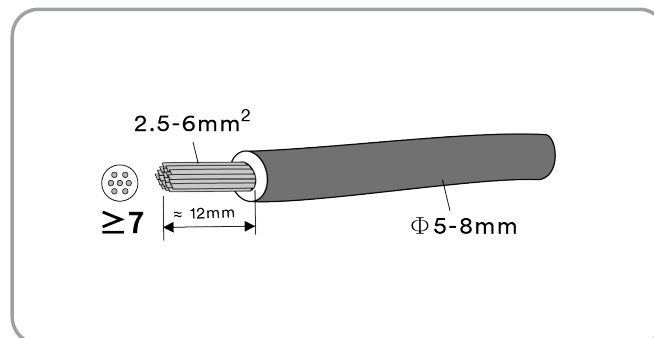

Step 2: Assemble the cable ends with the crimping pliers.

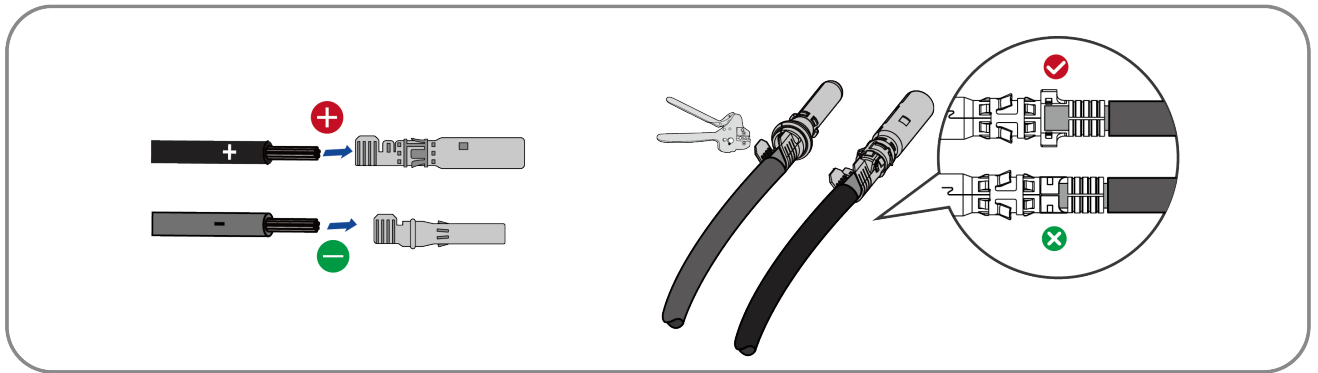

Step 3: Lead the cable through cable gland, and insert into the insulator until it snaps into place. Gently pull the cable backward to ensure firm connection. Tighten the cable gland and the insulator (Torque 2.5-3Nm).

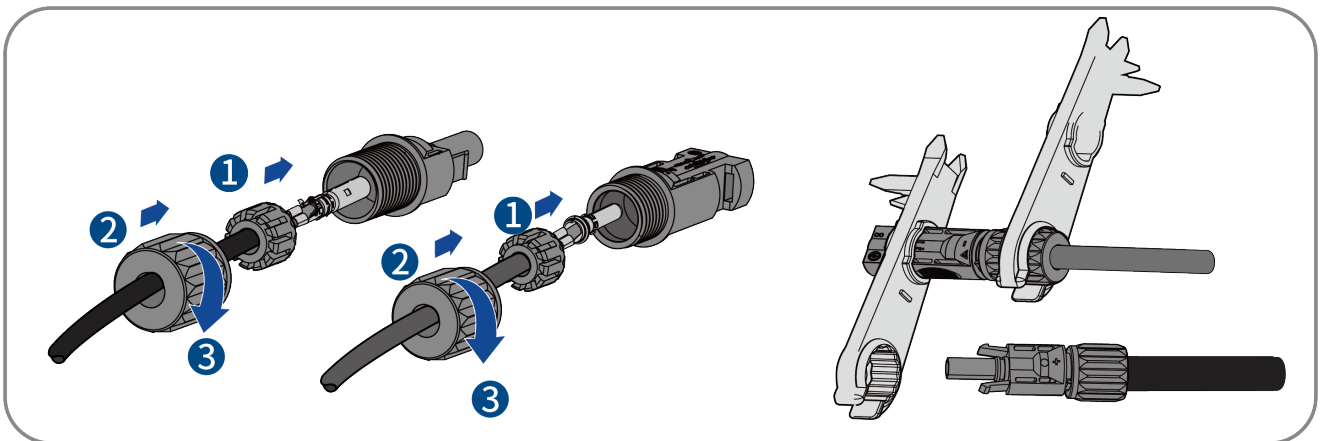

Step 4: Ensure that the cable is correctly positioned.

6.5.3 Connecting the PV module

⚠ DANGER

Danger to life due to high voltages in the inverter!

When exposed to light, the PV modules generate high DC voltage which is present in the DC cables. Touching live DC cables results in death or lethal injuries due to electric shock..

- Before connecting the PV array, ensure that the DC switch is switched off and that it cannot be reactivated.
- Do not disconnect the DC connectors under load.

NOTICE

The inverter can be destroyed by overvoltage!

If the voltage of the strings exceeds the maximum DC input voltage of the inverter, it can be destroyed due to overvoltage. All warranty claims become void.

- Do not connect strings with an open-circuit voltage greater than the maximum DC input voltage of the inverter.
- Check the design of the PV system.

Procedure:

Step 1: Ensure that the individual miniature circuit-breaker is switched off and ensure that it cannot be accidentally reconnected.

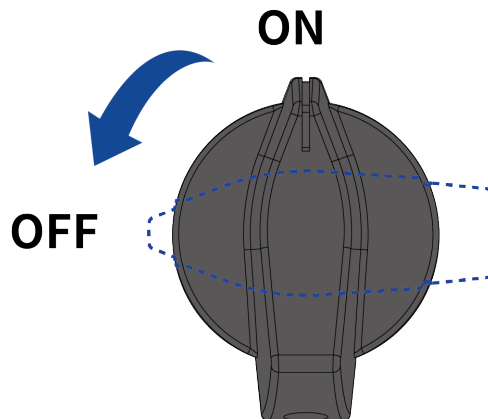

Step 2: Ensure that the DC switch is switched off and ensure that it cannot be accidentally reconnected.

Step 3: Ensure that there is no ground fault in the PV array.

Step 4: Check whether the DC connector has the correct polarity.

If the DC connector is equipped with a DC cable having the wrong polarity, the DC connector must be reassembled. The DC cable must always have the same polarity as the DC connector.

Step 5: Ensure that the open-circuit voltage of the PV array does not exceed the maximum DC input voltage of the inverter.

Step 6: Connect the assembled DC connectors to the inverter until they audibly snap into place.

Type 1 DC connector:

- Connect the assembled DC connectors to the inverter.

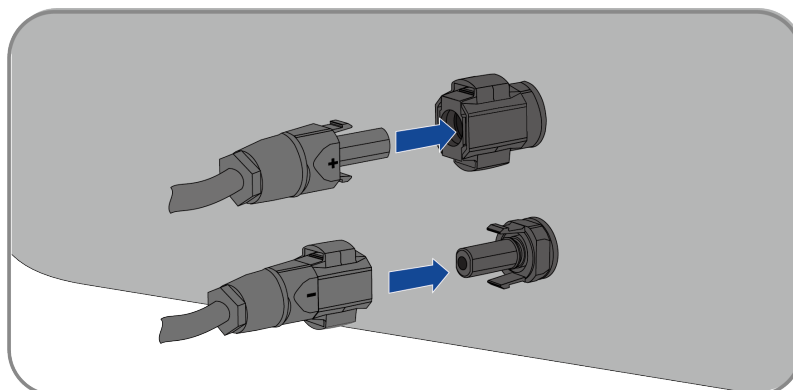

- For unused DC connectors, push down the clamping bracket and push the swivel nut up to the thread. Insert the DC connectors with sealing plugs into the corresponding DC inputs on the inverter.

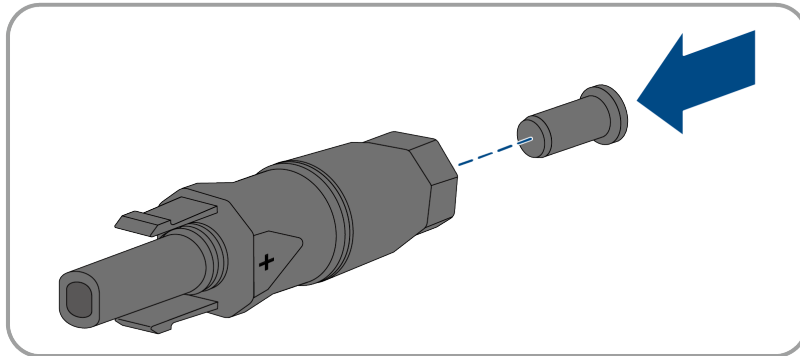
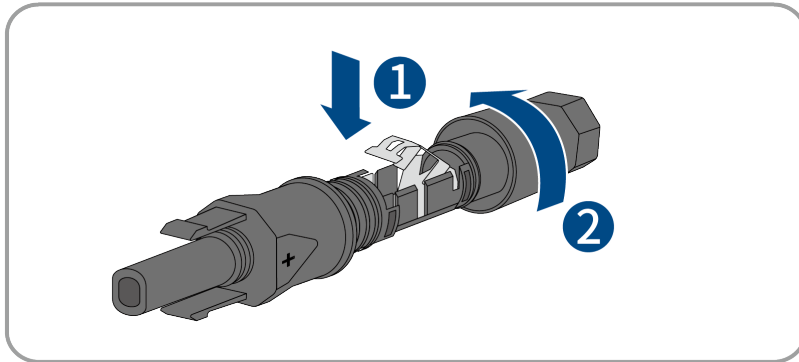

- Insert the DC connectors with sealing plugs into the corresponding DC inputs on the inverter.

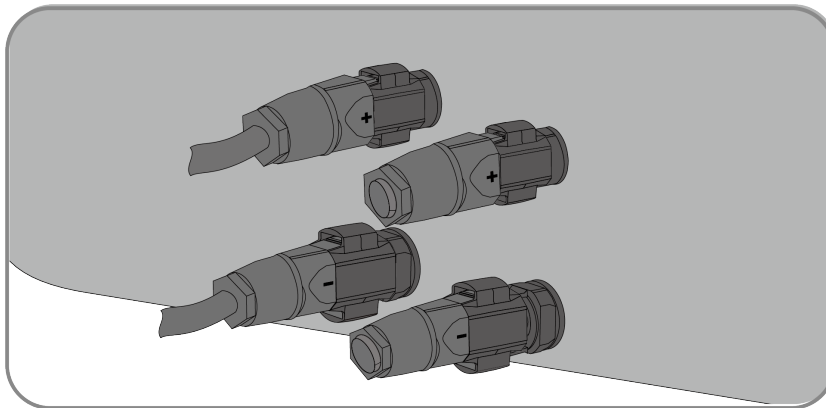

Type 2 DC connector:

- Connect the assembled DC connectors to the inverter.

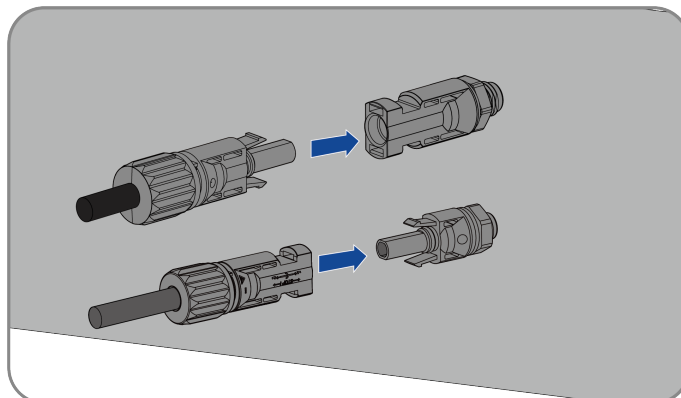

- For unused DC connectors, push down the clamping bracket and push the swivel nut up to the thread. Insert the DC connectors with sealing plugs into the corresponding DC inputs on the inverter.

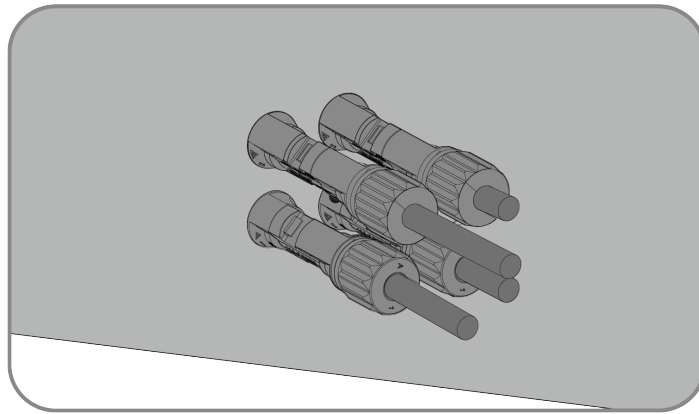

Check the positive and negative polarity of the PV strings, and connect the PV connectors to corresponding terminals only after ensuring polarity correctness. (The graph uses the type 2 connector as an example only.)

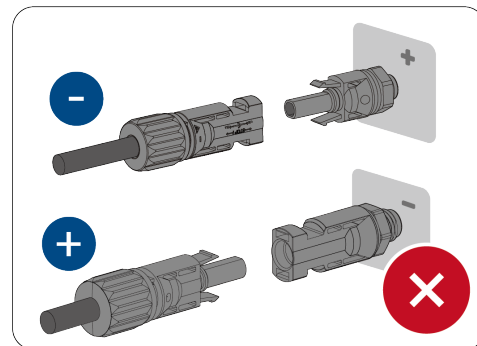
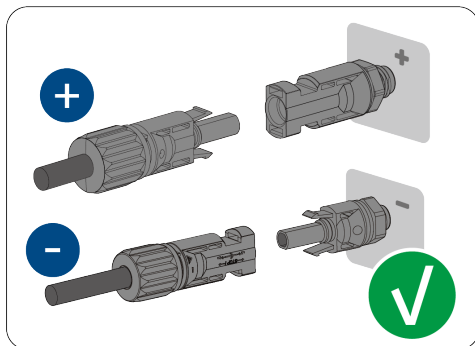

Step 7: Ensure that all DC connectors and the DC connectors with sealing plugs are securely in place.

Complete the installation.

6.6 Battery connection

6.6.1 Requirements for the Battery connection

Cable Requirements

Assemble the Battery connectors as described in the following.

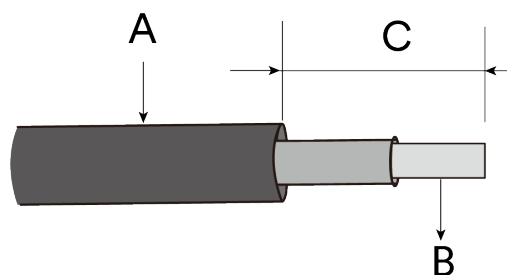

Item	Description	Value
A	External diameter	10-12 mm
B	Copper cable conductor cross-section	20~25 mm ²
C	Sheath stripping length	≤ 55 mm

6.6.2 Assembling the Battery connectors

Procedure:

Step 1: Guide the heat shrink tubing over the uninsulated crimp point and crimp the OT/DT terminal.

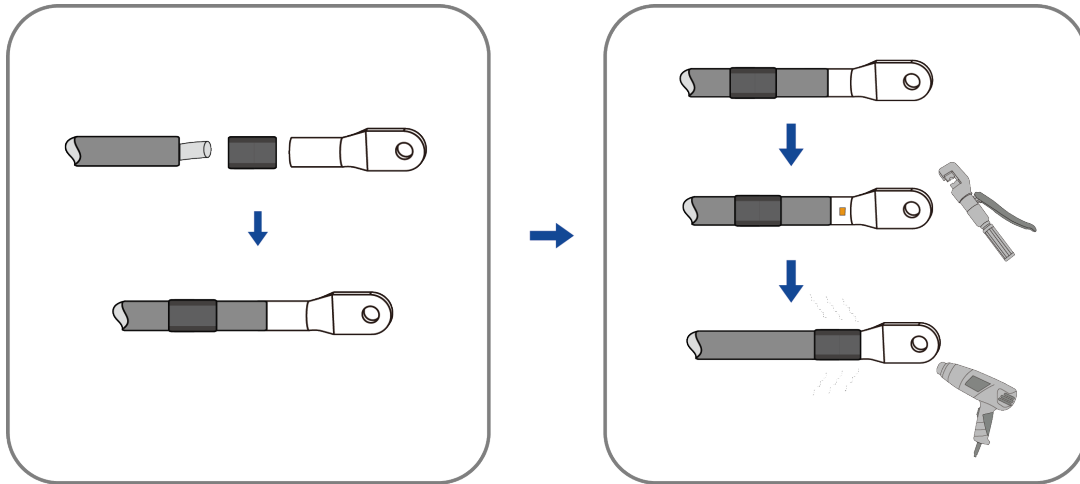

Step 2: Route the cables through the battery terminal cover.

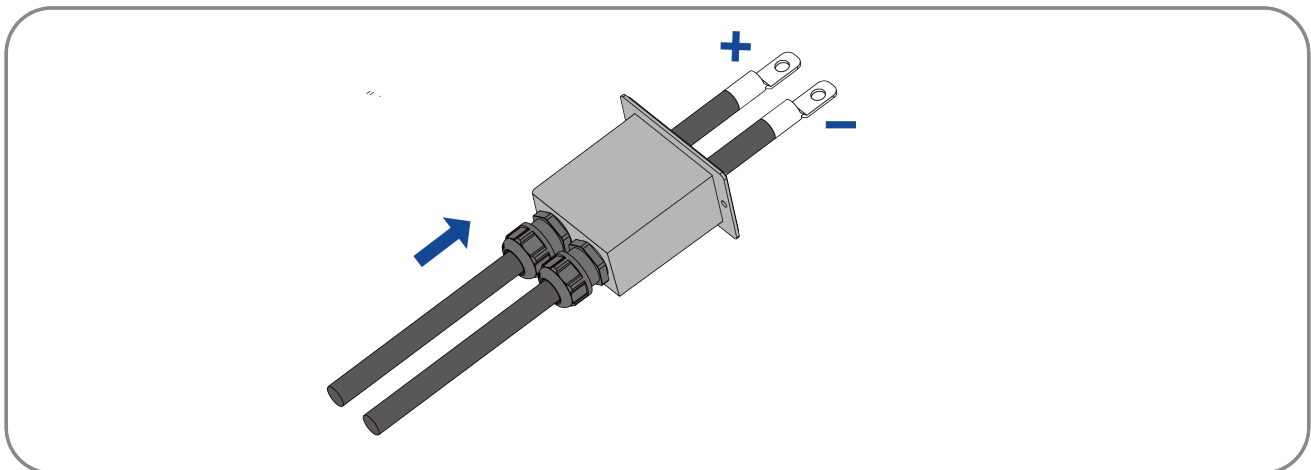

6.6.3 Connecting the Battery connectors

Step 1: Screw the cable terminal lugs to the socket through the battery terminal cover (Torque 4.0 N·m).

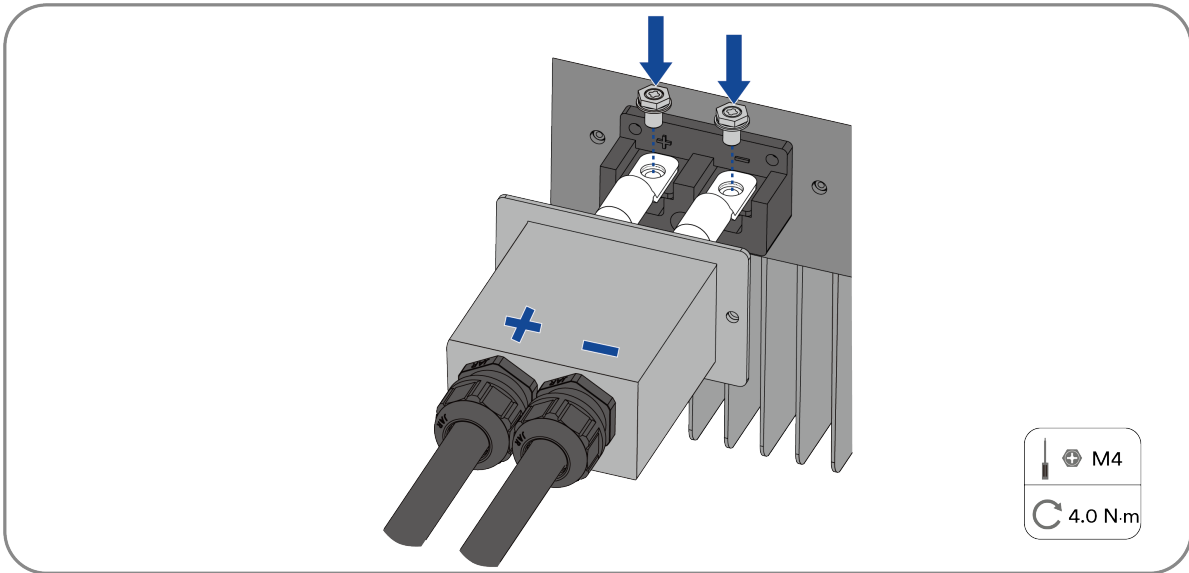

Step 2: Tighten the cable gland nuts (Torque 1.6 N·m).

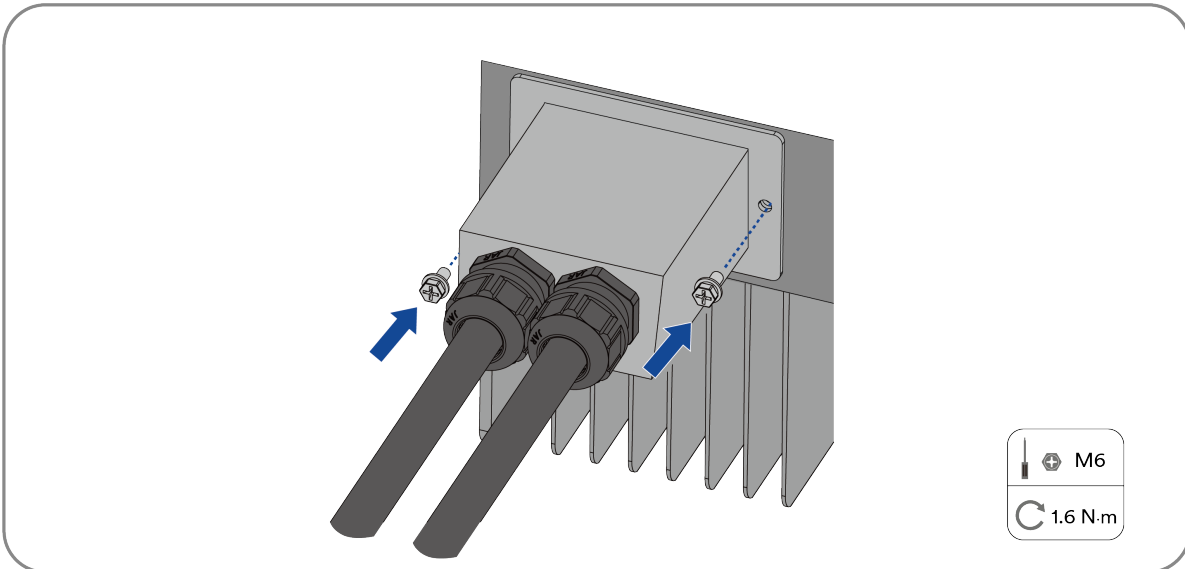

Step 3: Tighten the battery terminal cover.

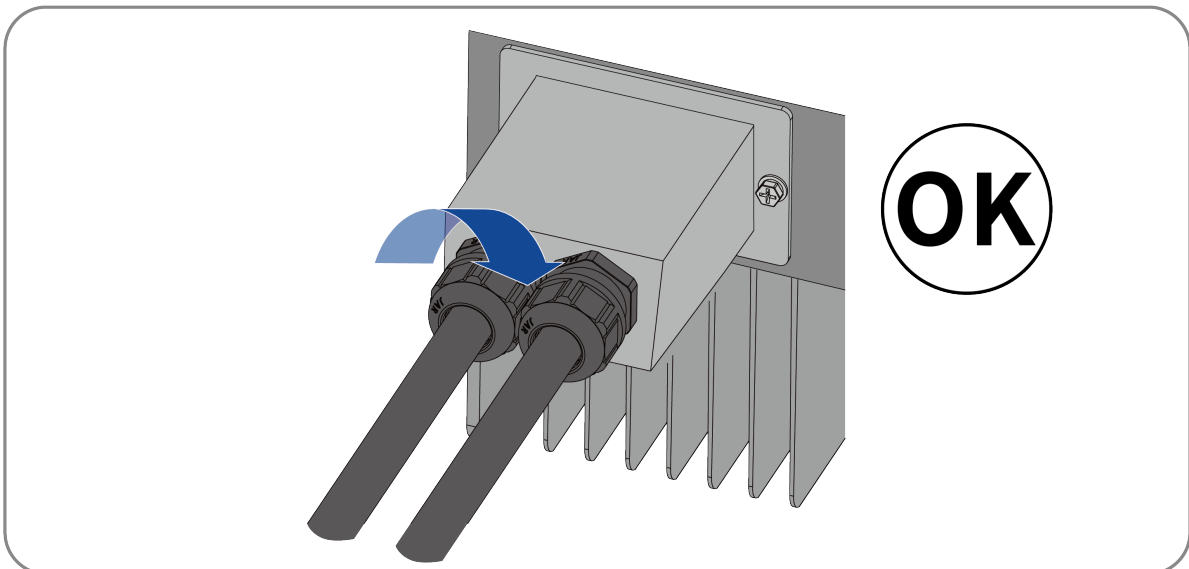

Complete the installation.

6.7 Wi-Fi stick connection

Procedure:

Step 1: Use the Wi-Fi stick included in the scope of delivery.

Step 2: Remove the dust and waterproof cover of the Ai-Dongle on the inverter and retain it.

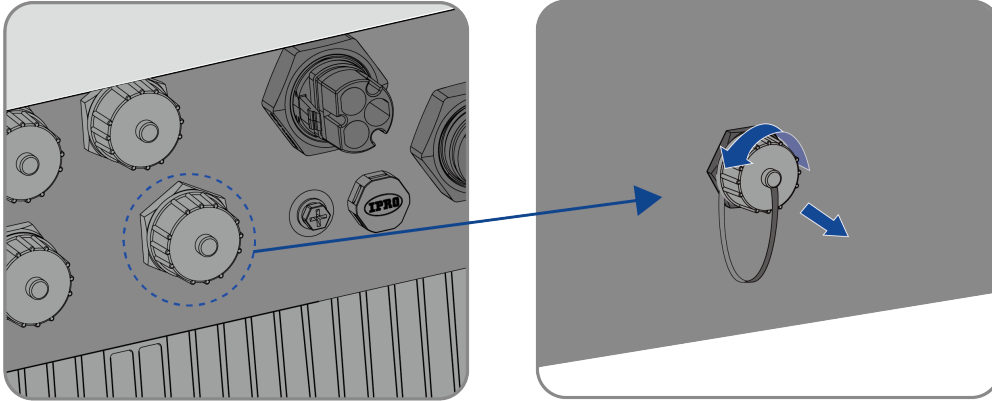

Step 3: Attach the Wi-Fi stick to the connection port in place and tighten it by hand with the nut on the Wi-Fi stick.

Make sure the Wi-Fi stick is securely connected and the label on the Wi-Fi stick can be easily seen to allow for the scanning of the QR code during commissioning.

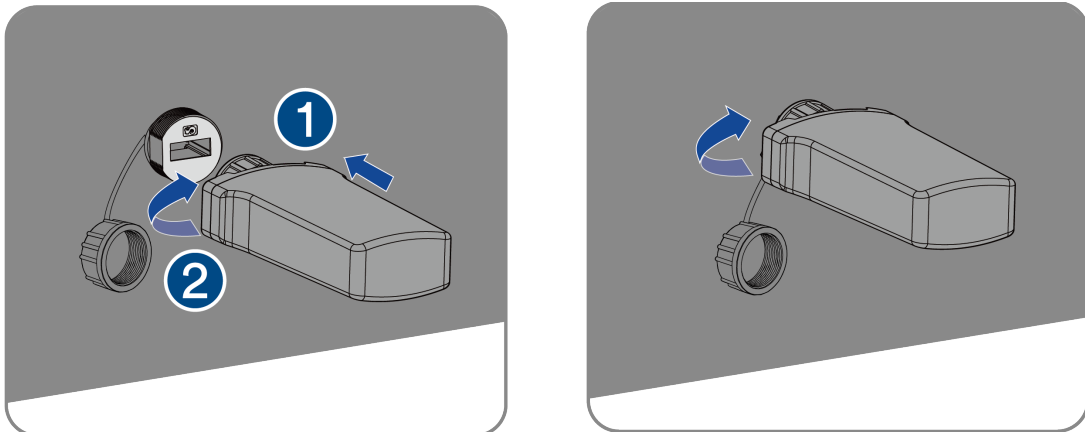

NOTICE

Rotating the communication modular will damage the communication modular!

The communication modular is protected by locking nuts to protect the reliability of the connection. If the body of the communication modular is rotated, the communication modular will be damaged.

It can only be locked by a nut.

- Do not rotate the communication modular body.

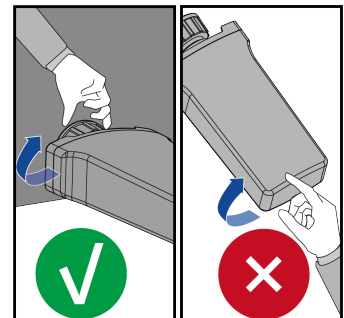

Complete the installation.

6.8 BMS CAN cable connection

Procedure:

Step 1: RS485 cable pin assignment as below, strip the wire as shown in the figure, and crimp the copper wire to the appropriate OT terminal (according to DIN 46228-4, provided by the customer)

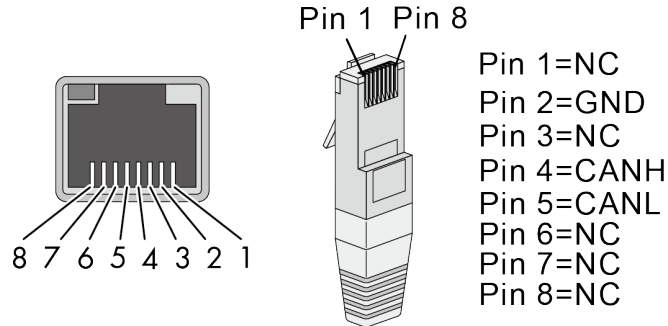

Step 2: Insert the network cable into the RS485 communication client attached.

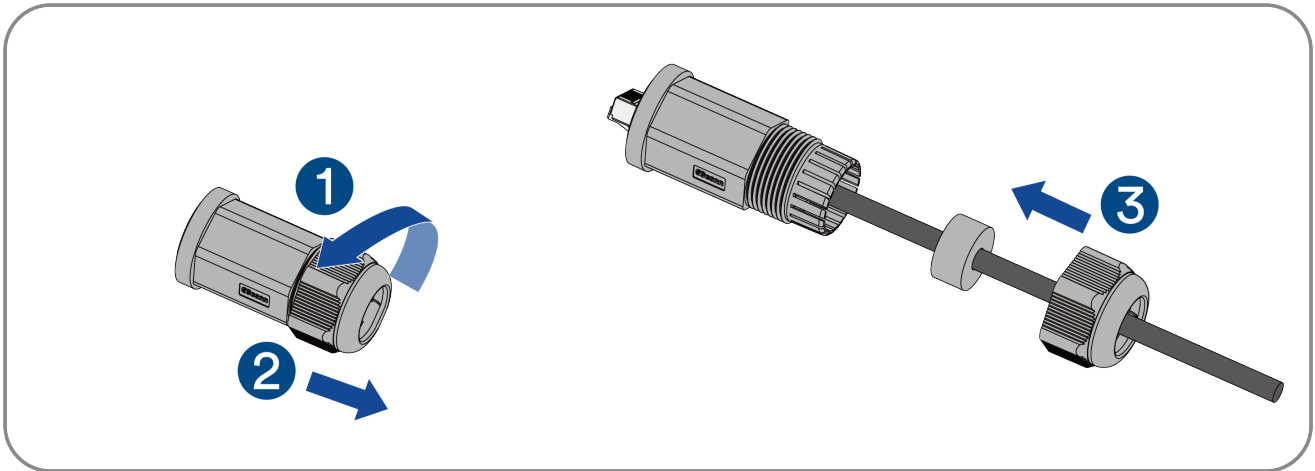

Step 3: Unscrew the communication port cover cap in the following arrow sequence.

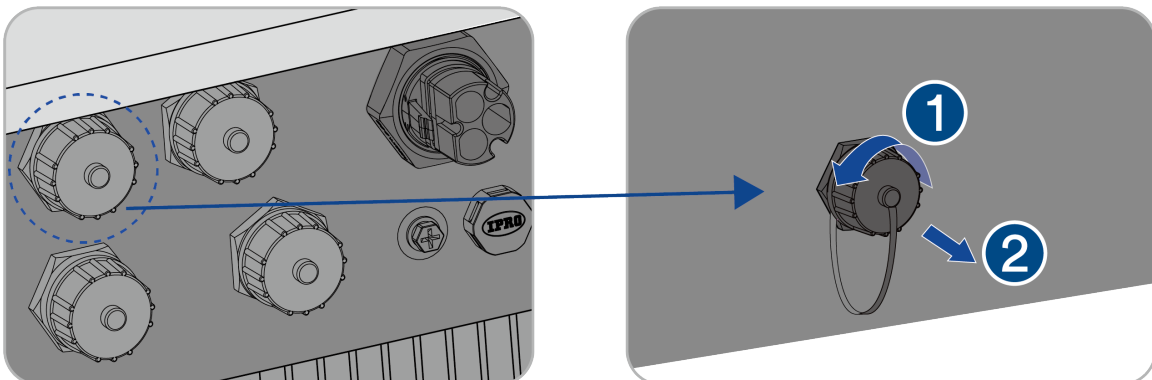

Step 4: Insert the network cable into the corresponding communication terminal of the machine according to the arrow sequence, tighten the thread sleeve, and then tighten the forcing nut at the tail.

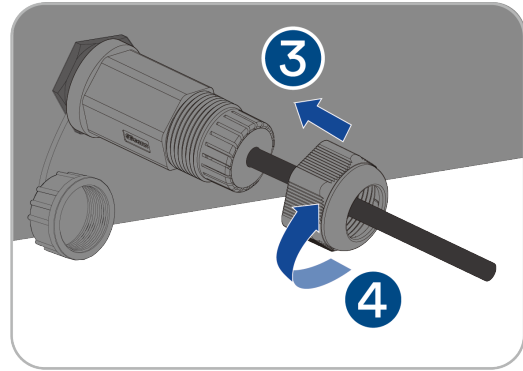
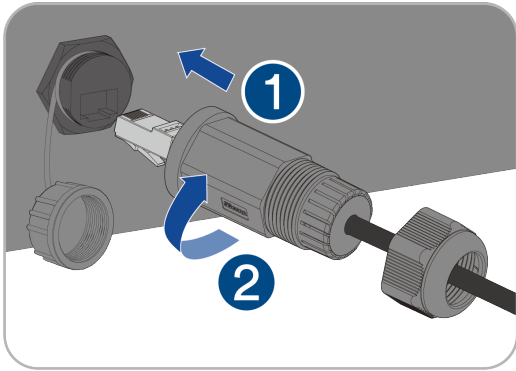

Complete the installation.

6.9 DRED cable connection

Procedure:

Step 1: RJ45 cable pin assignment as below, strip the wire as shown in the figure, and crimp the copper wire to the appropriate OT terminal (according to DIN 46228-4, provided by the customer)

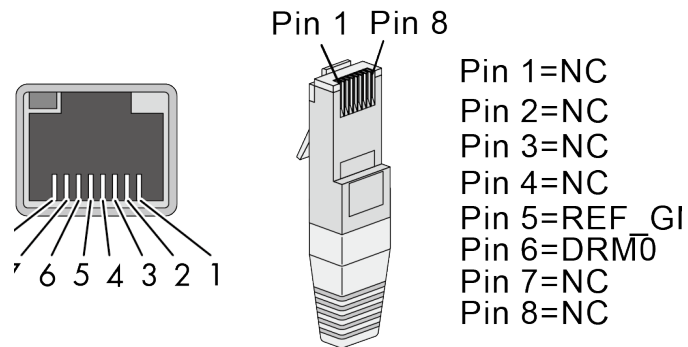

Step 2: Insert the network cable into the RJ45 communication client attached.

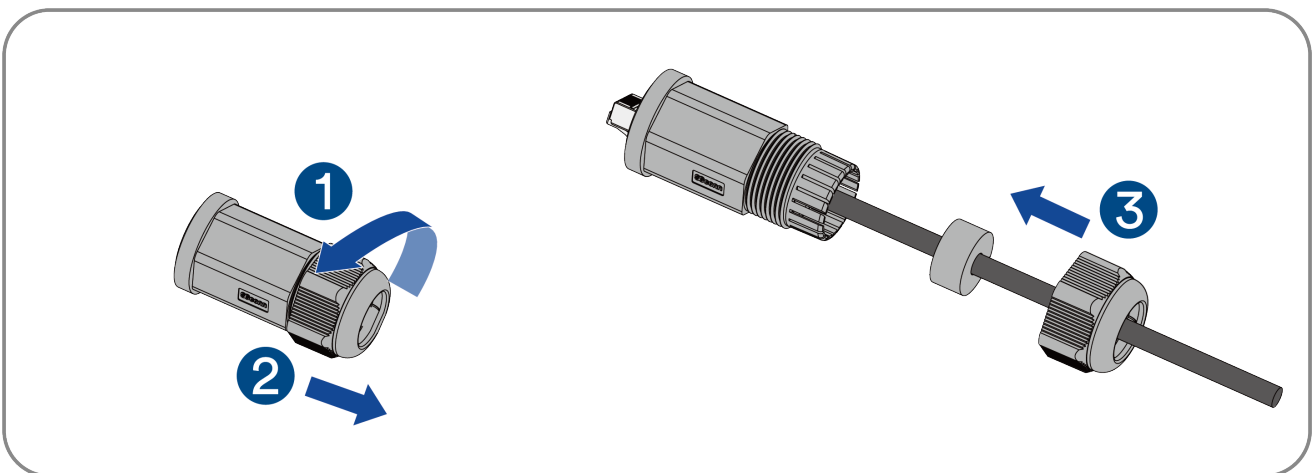

Step 3: Unscrew the communication port cover cap in the following arrow sequence.

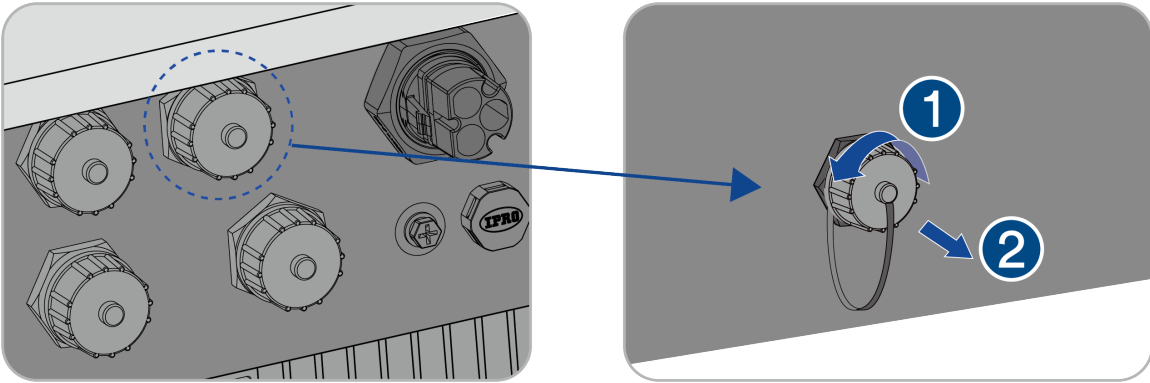

Step 4: Insert the network cable into the corresponding communication terminal of the machine according to the arrow sequence, tighten the thread sleeve, and then tighten the forcing nut at the tail.

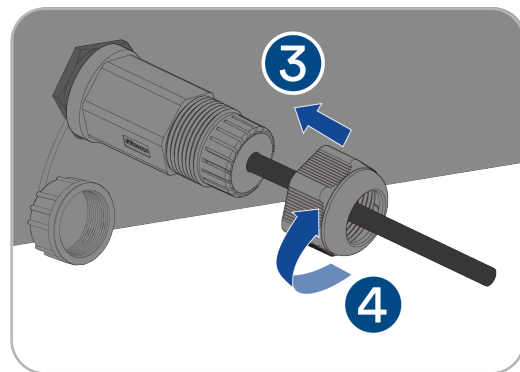
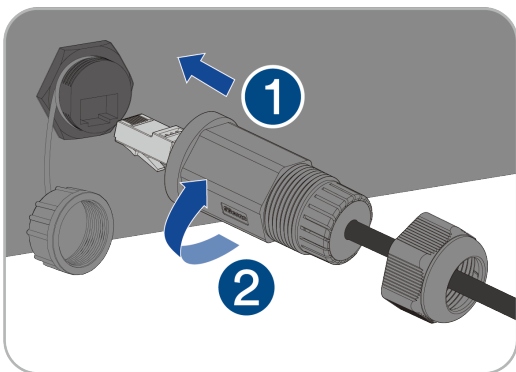

Complete the installation.

6.10 Smart meter cable connection

6.10.1 Connection Procedure

Procedure:

Step 1: RS485 cable pin assignment as below, strip the wire as shown in the figure, and crimp the copper wire to the appropriate OT terminal (according to DIN 46228-4, provided by the customer).

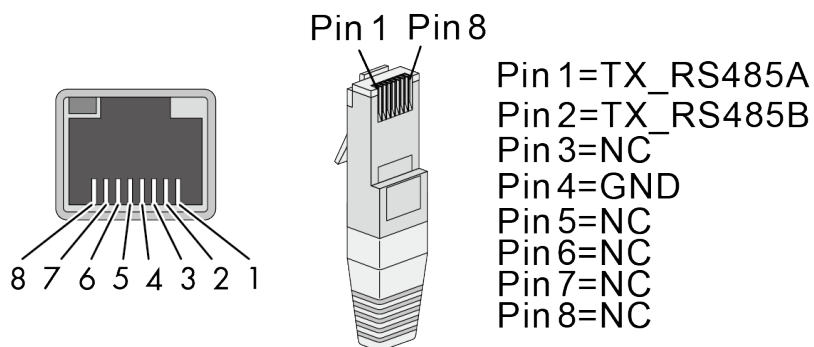

Step 2: Insert the network cable into the RS485 communication client attached.

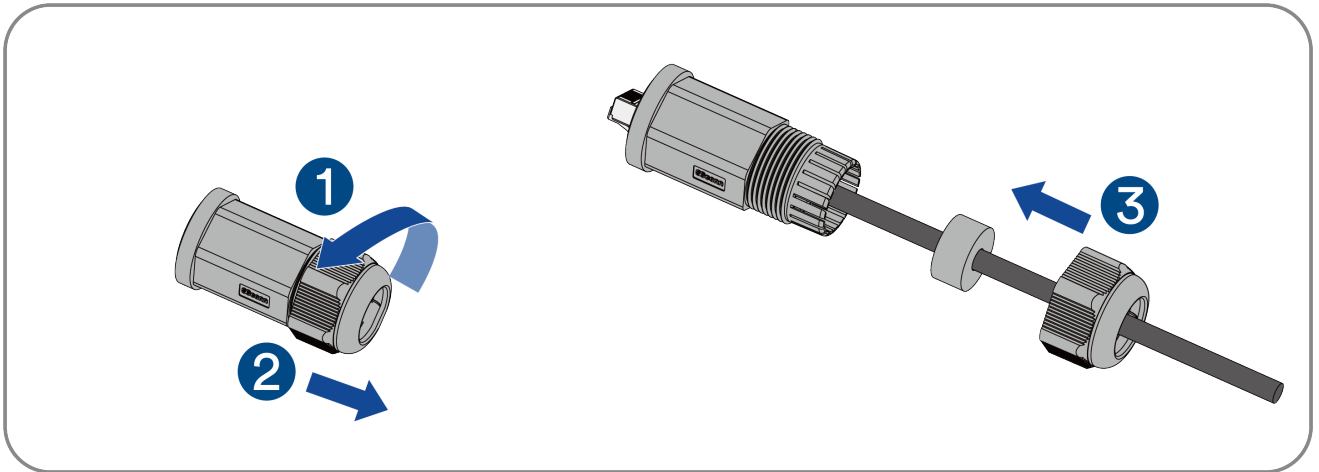

Step 3: Unscrew the communication port cover cap in the following arrow sequence.

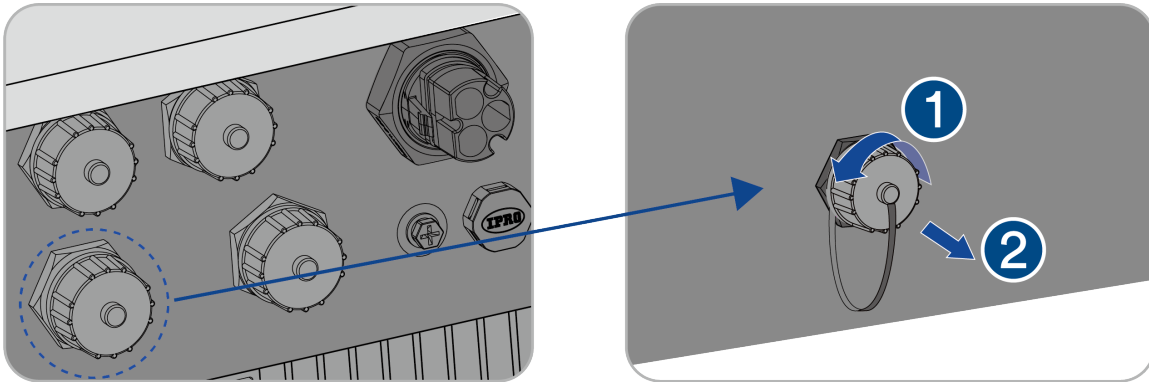

Step 4: Insert the network cable into the corresponding communication terminal of the machine according to the arrow sequence, tighten the thread sleeve, and then tighten the forcing nut at the tail.

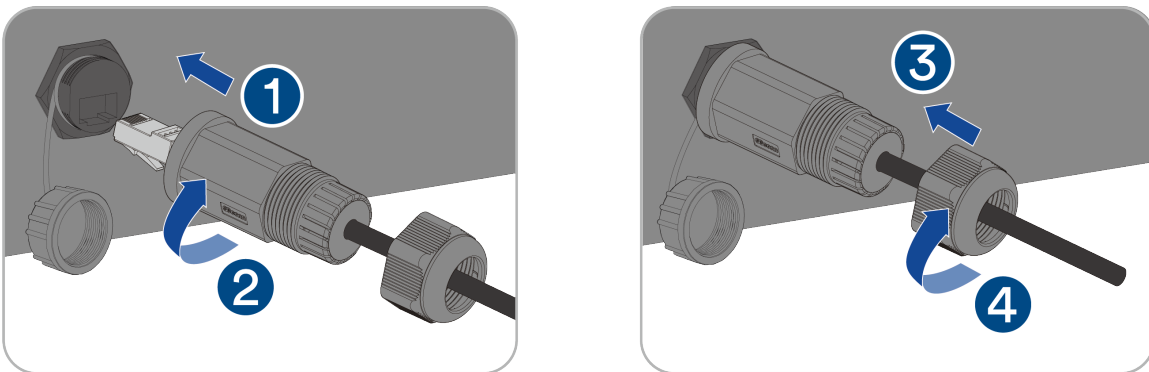

Complete the installation.

6.10.2 Smart meter connection

The grid structure supported by the product is TN-S. For other grid types, please refer to 4.4.

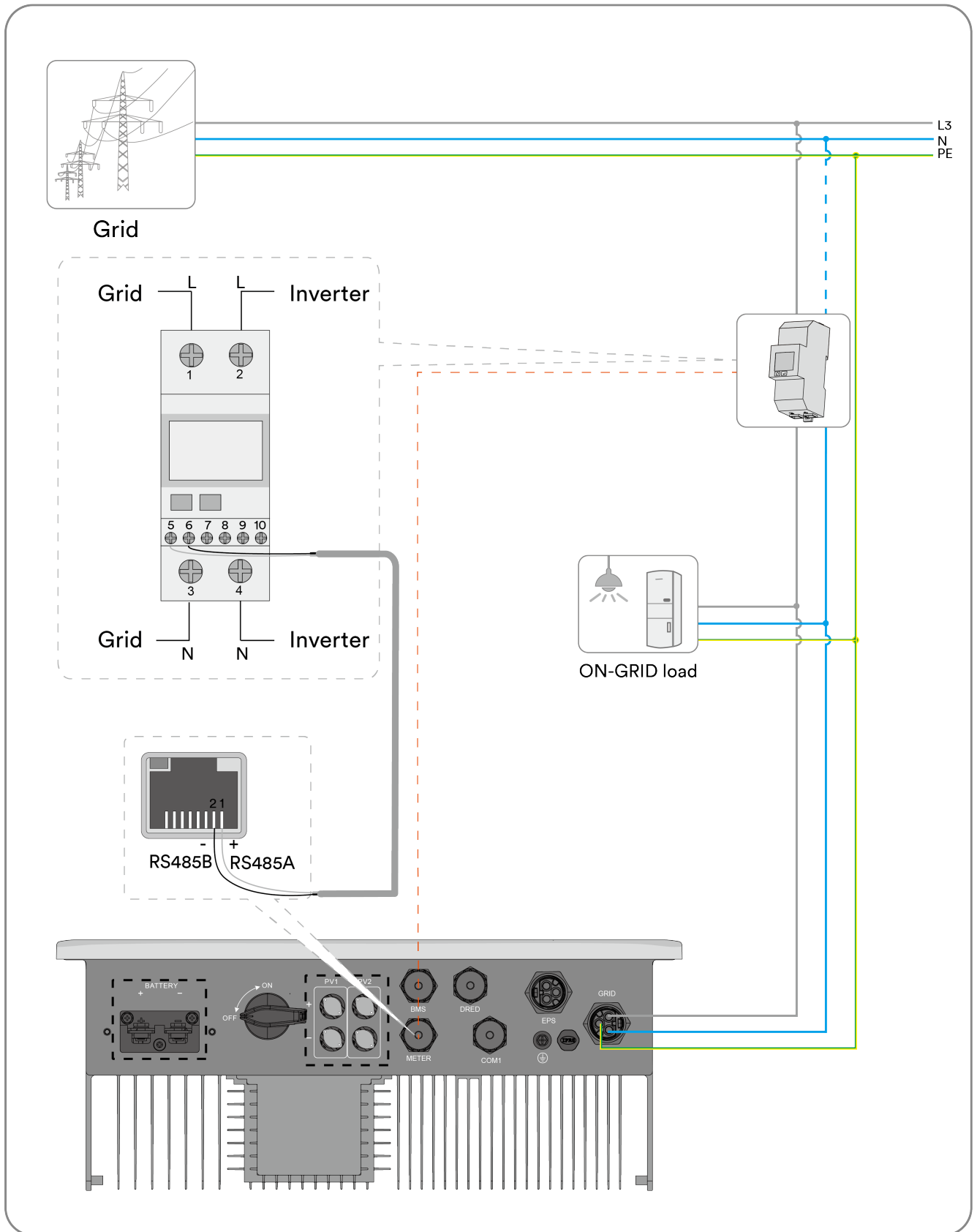

7 Commissioning and operating

7.1 Inspection before commissioning

CAUTION

Danger to life due to high voltages on DC conductors!

When exposed to sunlight, the PV array generates dangerous DC voltage which is present in the DC conductors. Touching the DC and AC conductors can lead to lethal electric shocks..

- Only touch the insulation of the DC cables.
- Only touch the insulation of the AC cables.
- Do not touch ungrounded PV modules and brackets.
- Wear personal protective equipment, such as insulating gloves.

Check the following items before starting the inverter:

- Make sure the inverter DC switch and external circuit breaker are disconnected.
- Make sure the inverter has been correctly mounted with wall bracket.
- Make sure nothing is left on the top of the inverter.
- Make sure the communication cable and AC connector have been correctly wired and tightened.
- Make sure the inverter's exposed metal surface has a ground connection.
- Make sure the DC voltage of the strings does not exceed the permitted limits of the inverter.
- Make sure the DC voltage has the correct polarity.
- Make sure that the insulation resistance to ground is greater than the insulation resistance protection value.
- Make sure the grid voltage at the point of connection of the inverter complies with the permitted value of the inverter.
- Make sure the AC circuit breaker complies with this manual and all applicable local standards.

7.2 Commissioning procedure

If all of the items mentioned above meet the requirements, proceed as follows to start up the inverter for the first time.

Step 1: Turn the DC switch of the inverter to "ON" position and start battery, but keep the breakers on EPS and grid port to "OFF" position.

Step 2: Connect the inverter with soplant APP, For details, please refer to 8.4. Then set grid code, operation mode(refer to 4.7), meter or CT type, battery model and SOC limit refer to 8.4.

Step 3: Turn the breakers on EPS and grid port to "ON" position. If the irradiation and grid conditions meet requirements, the inverter will operate normally.

Step 4: Observe the LED indicator to ensure inverter operates normally, check the inverter and battery parameters in APP.

8 Solplanet APP

8.1 Brief introduction

The Solplanet App can establish communication connection to the inverter via the WLAN, there by achieving near-end maintenance on the inverter. Users can view inverter information and set parameters through the App.

8.2 Download and install

Scan the following QR code to download and install the App according to the prompt information.



Android



iOS

8.3 Create an account

If you do not have an account, you need to register a new account first.

Procedure:

Step 1: Open Solplanet App to enter the login screen, and tap “Do not have an account” to enter the next screen.

Step 2: The user groups “Business user” and “End user” need be selected according to your identity, and tap “Next step”.



The end user and the business user have the different permissions for setting parameters.

The end user only can set the parameter during commissioning. The business user has more permissions, but they need submit more identity authentication documents.

Step 3: Enter the right mobile phone number (Via SMS) or E-mail address (Via mail). And tap the “Send verification code”

Step 4: Enter the correct verification code to automatically enter the next page.

Step 5: Set the password and click “Register” to complete the registration.

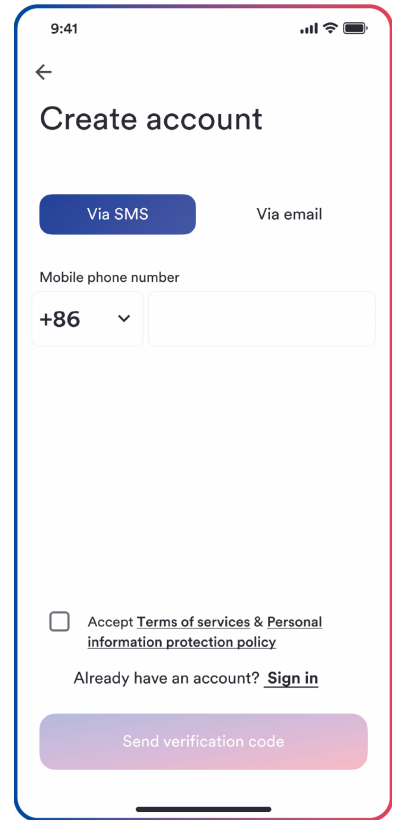
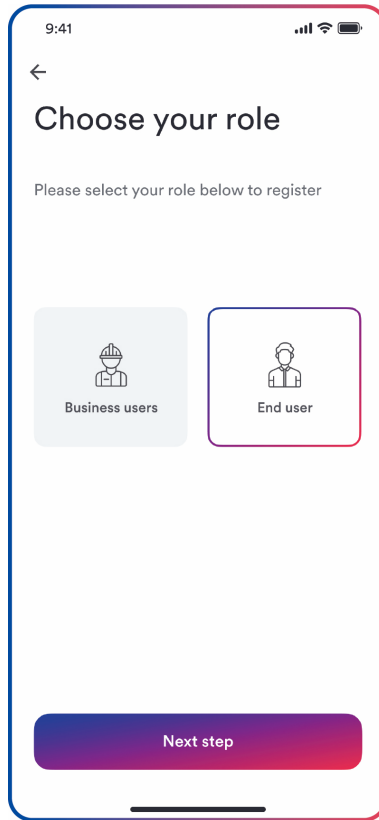
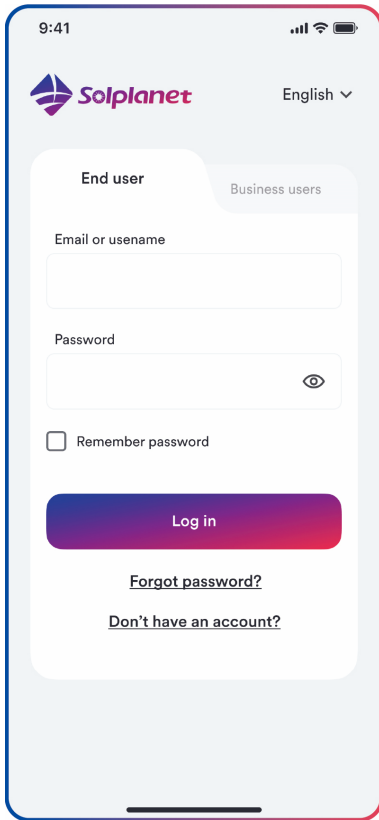

Step 1

Step 2

Step 3

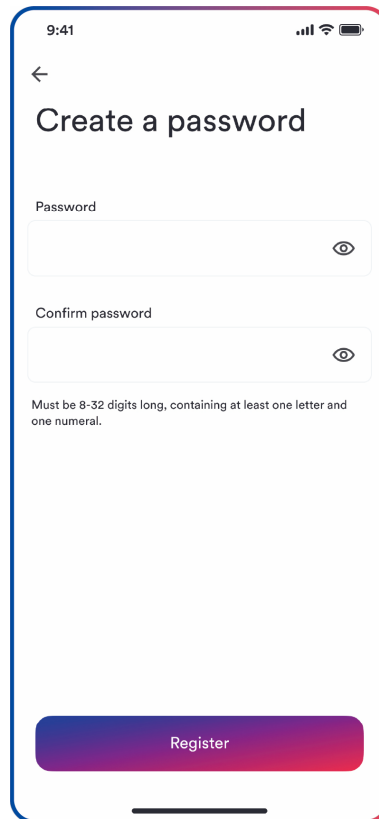
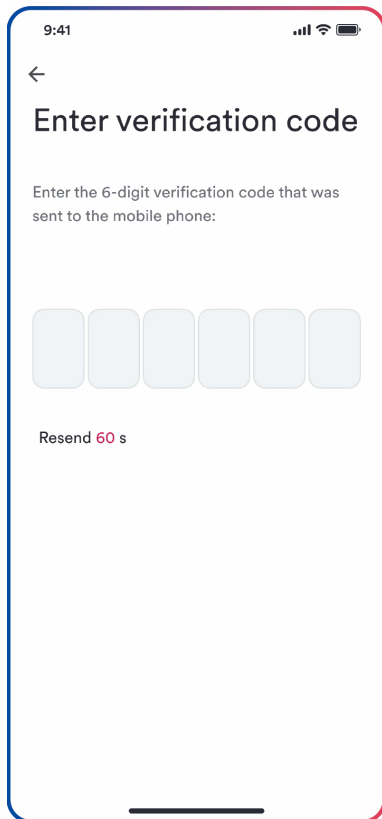

Step 4

Step 5

8.4 Create a plant

Procedure:

Step 1: Open Solplanet App to enter the login screen, enter the account name and password, and tap “Log in” to enter the next screen.

Step 2: Tap the symbol “+” to enter the next screen, and tap “Create or modify a plant”, then the camera of the mobile automatically turns on, and scan the QR code of the Ai-dongle to enter the next screen, tap “Create new plant” to the next screen.

Step 3: Enter the PV plant information in all fields marked with a red asterix, and tap “Create” to enter the next screen.

Step 4: After the planet created, tap “Add dongle to the plant”, and tap “Add to plant” to the next screen.

Step 5: Tap the inverter serial number that matches your inverter, then the setting parameter can be set. The detail description can be found at section 8.5.



The grid code should be chosen at this step. And the parameters also should be set if the grid company has the different requirements.

Step 6: The Energy Management shall be set here. Tap “Energy storage settings” to the next page, then tap “Battery settings” to select the battery model, battery number and choose the energy management model. After the parameter configuration, tap “Confirm” and tap the left arrow to go back the inverter list page. Then tap “Next step” to enter the next page.



The battery discharge minimum is valid only in grid-connected mode, and the off-grid default is 10%.

Step 7: The parameter of the “Export Power Control” can be set, and tap “Save” after the parameter configuration. Then tap “Nest step” to enter the next page.

Step 8: Tap “Continue”, and choose WiFi network from the list, and enter WiFi network password. Then tap “continue” to enter the next step.

Step 9: Observe whether the Led blue light of the dongle stays on. If it is always on, it means that the network configuration is successful, and you can tap “Complete” to complete the configuration. Otherwise, you need to go back to the previous step and re-enter the Wi-Fi password.

Step 10: Now the new plant have been created. Tap the plant to review the information of the plant.

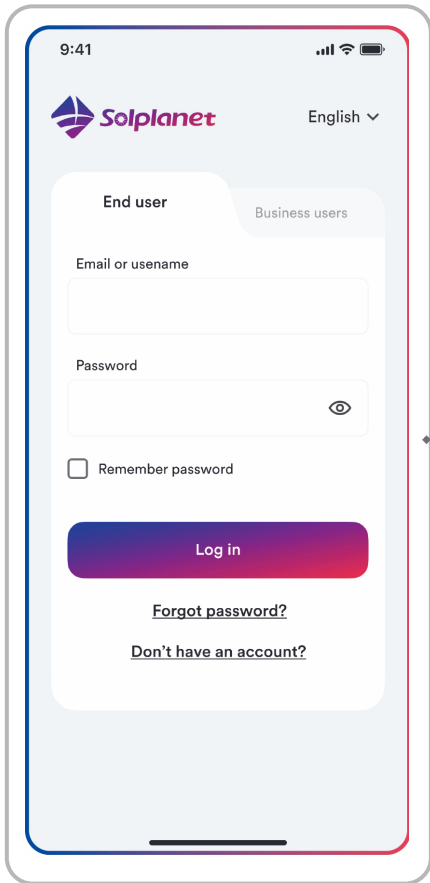

Step 1

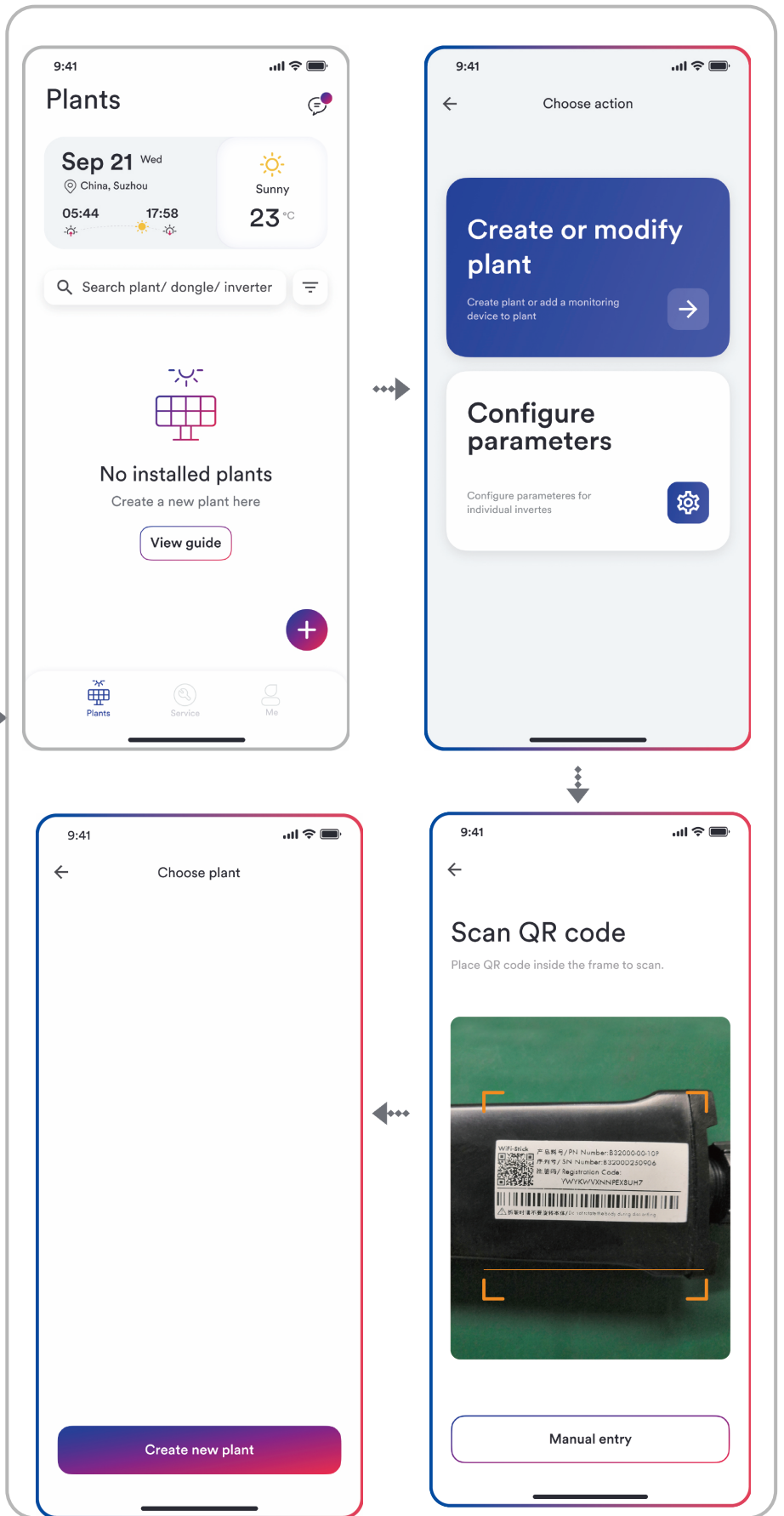

Step 2

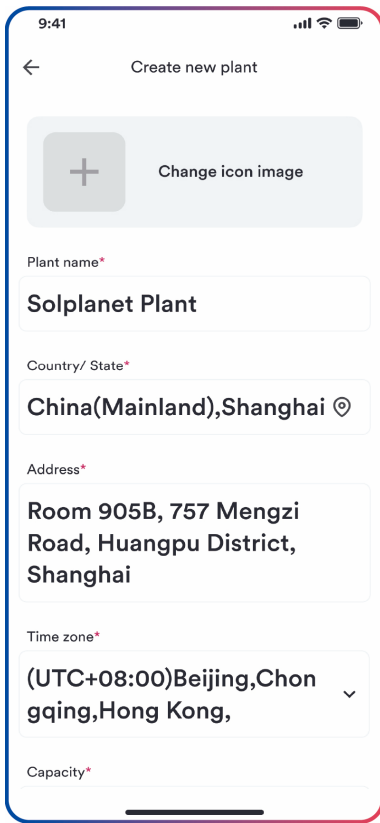

Step 3

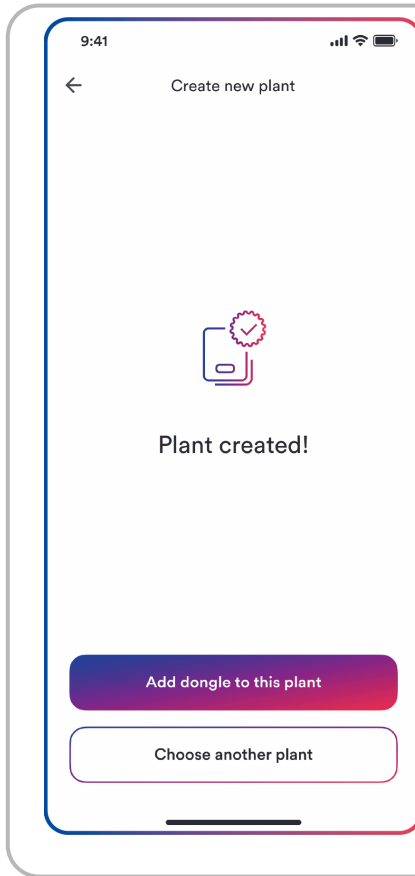

Step 4

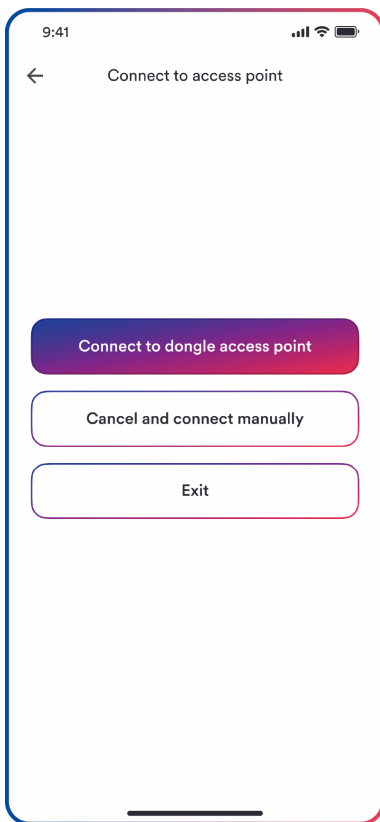
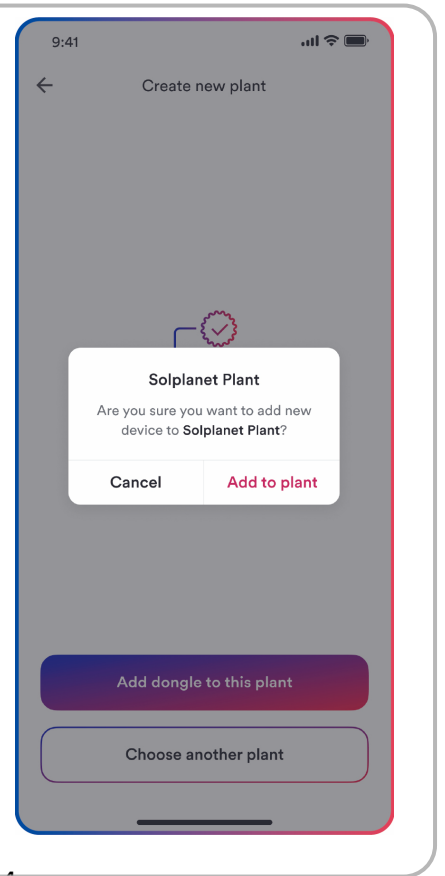

Step 5



Step 6

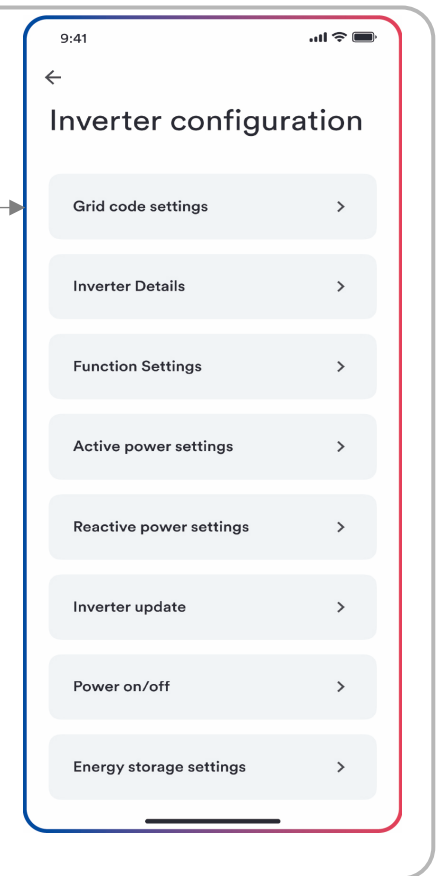

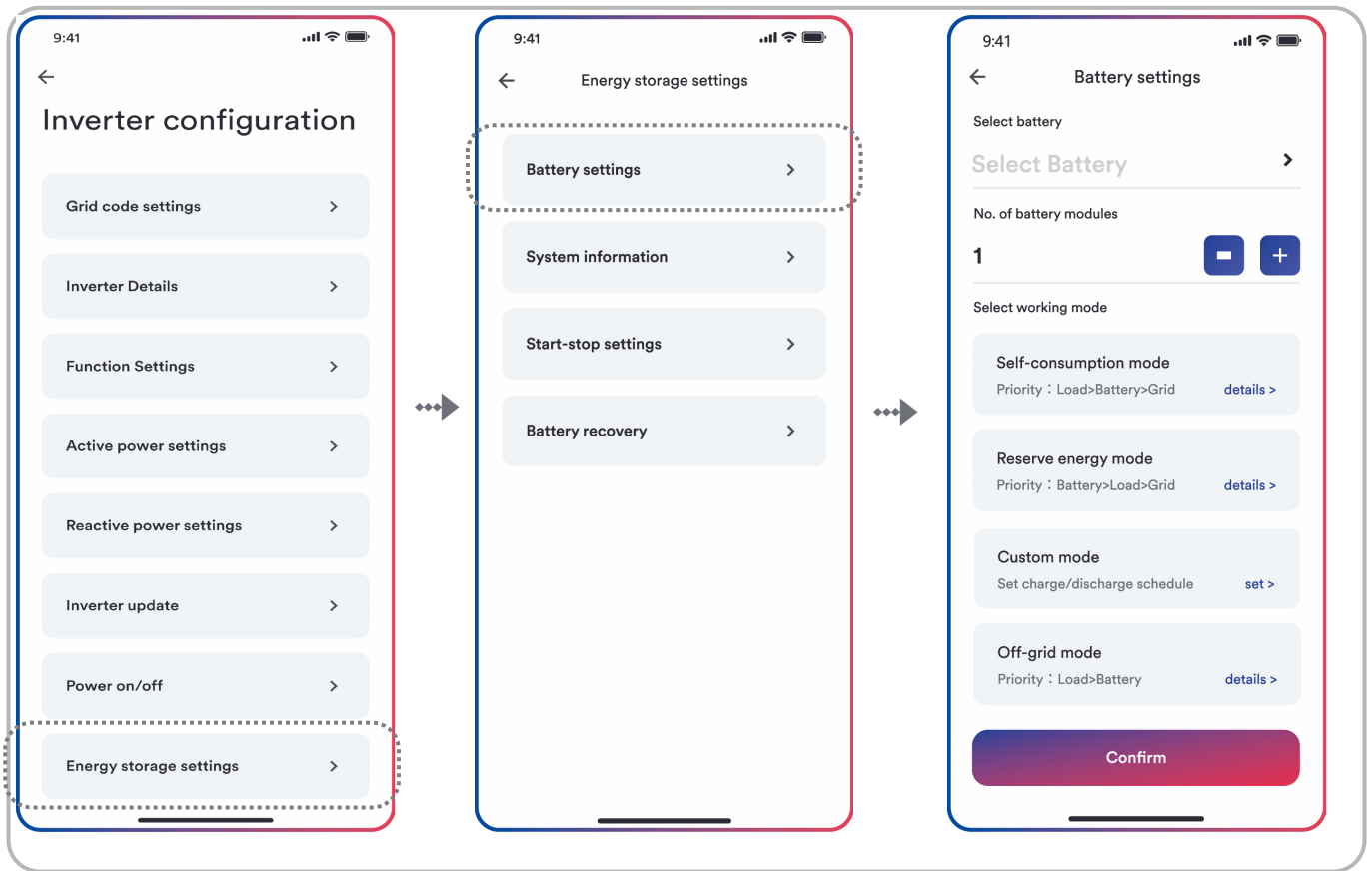

Step 7

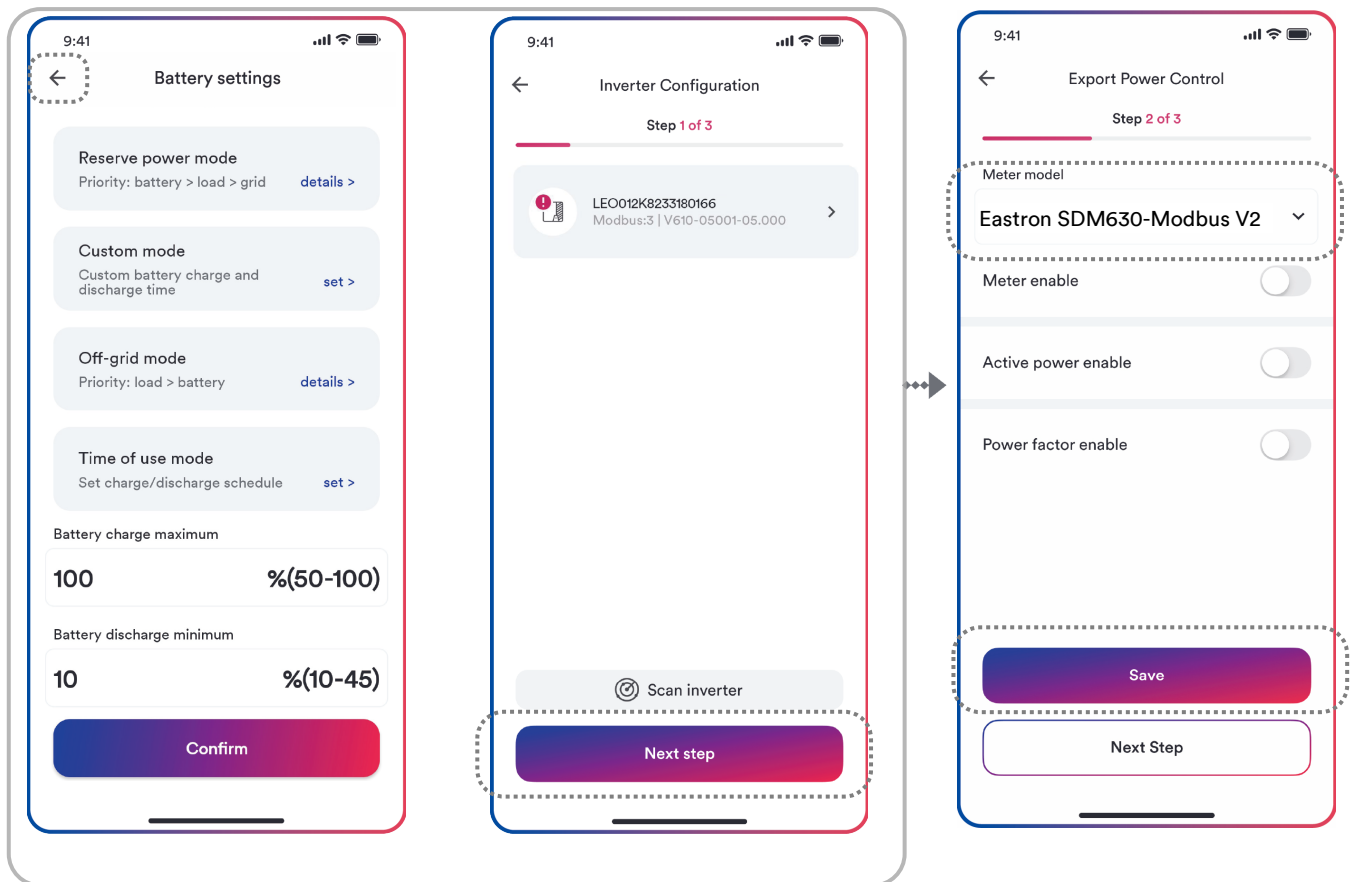

Step 7

Step 8

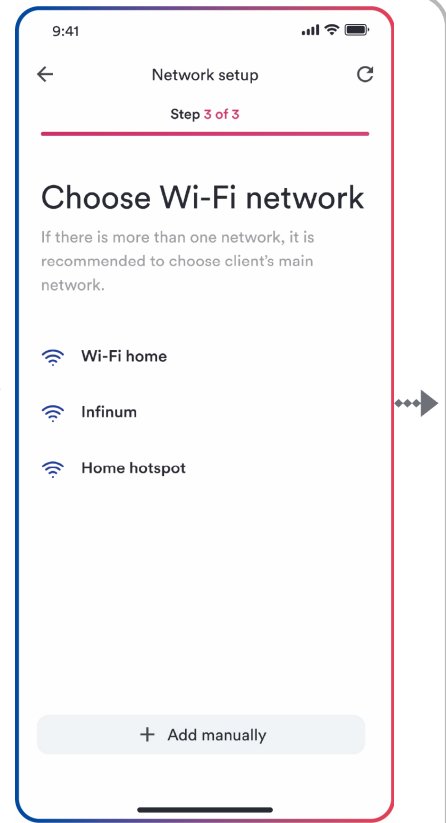
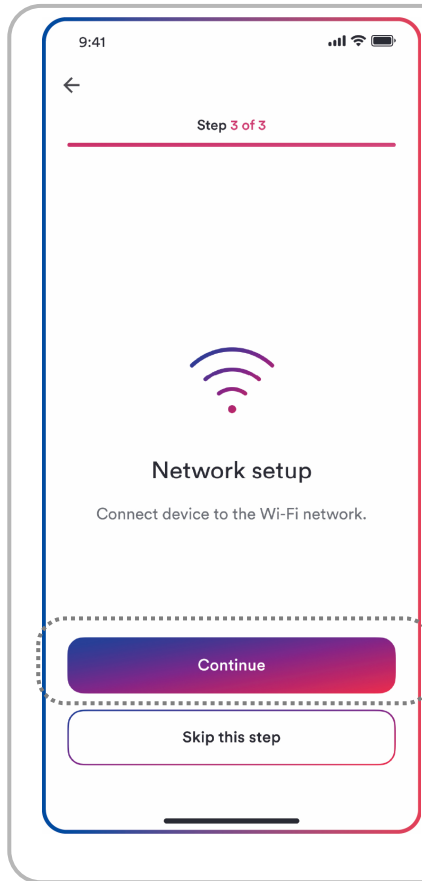
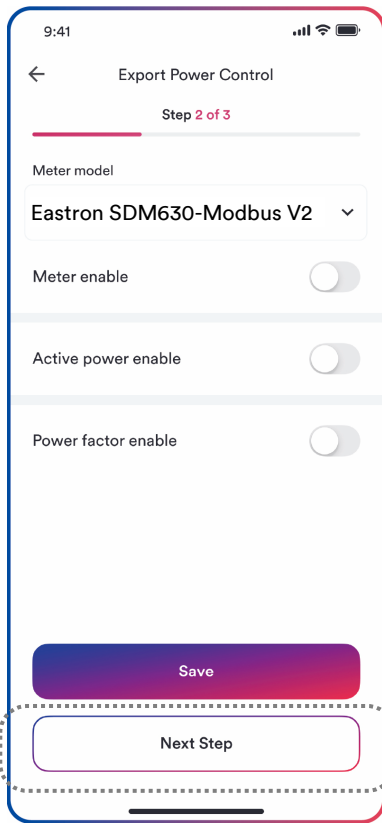

Step 8

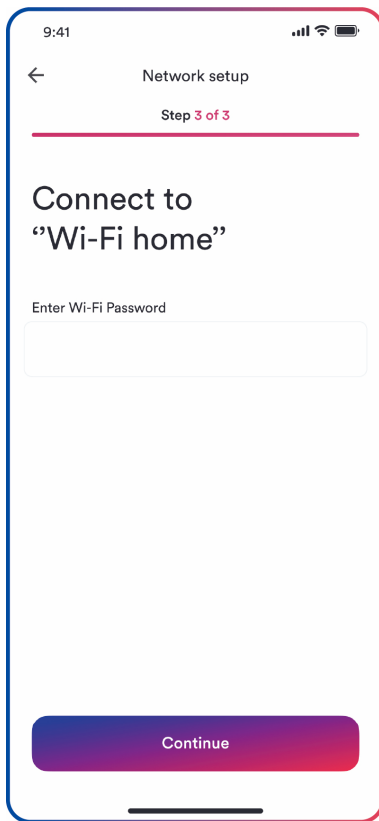

Step 9

Step 9

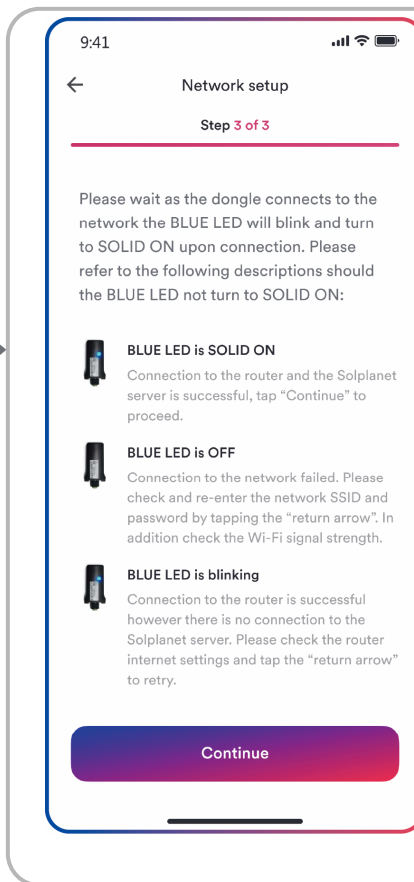

Step 10

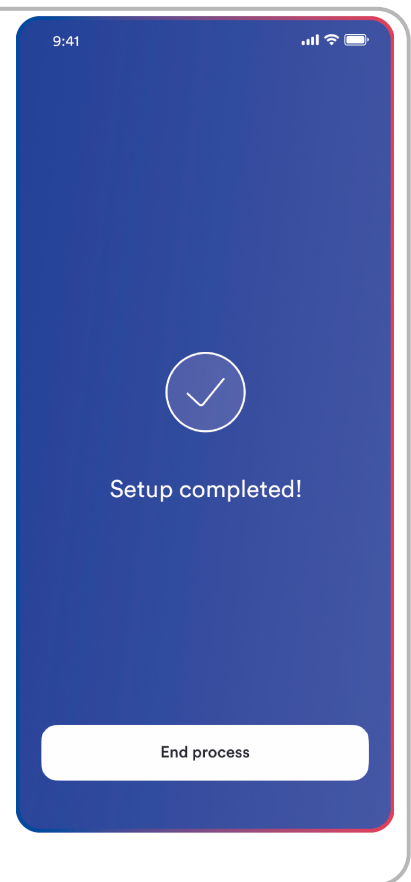

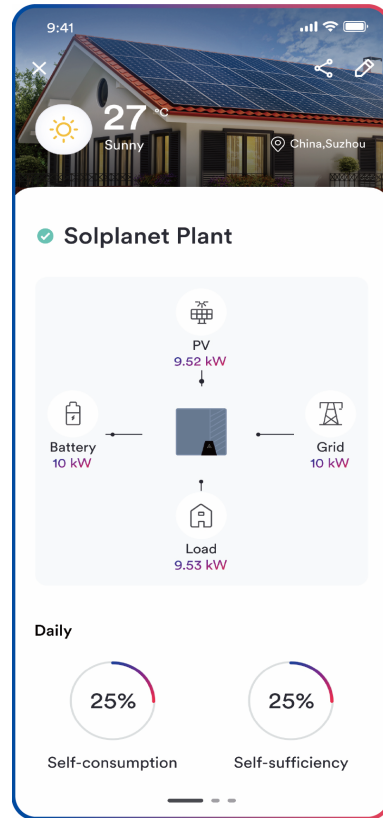
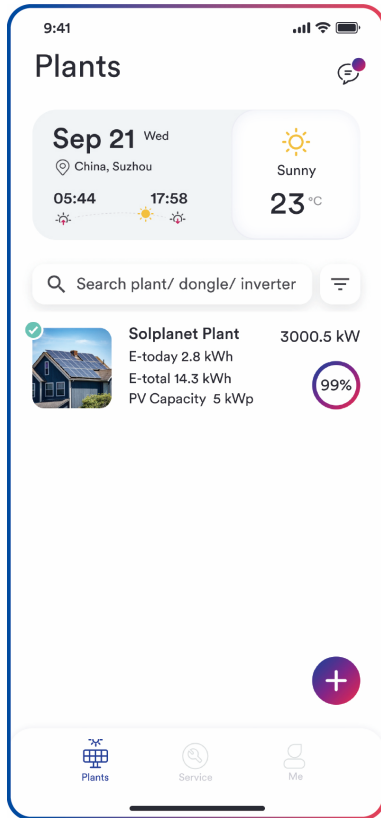

Step 11

8.5 Setting parameters

8.5.1 Inverter configuration

The Solplanet's products comply with local grid code when leaving the factory. But you still should check the grid code and the parameters according to the requirements of the installation site.

Once configuration of the product is completed, the product will start operating automatically

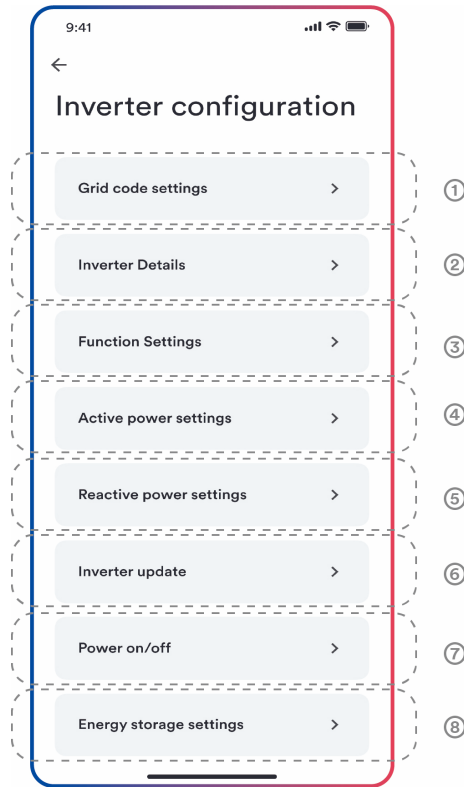

Table description

No.	Function	Description
①	Grid code settings	Choose a safety code. Configure the protection parameters. Configure the start operation parameters and automatic reconnection parameters.
②	Inverter Details	Show the general information of the inverter. Show the present operation value of the inverter.
③	Function settings	Active the general function. Active some special function.
④	Active power settings	Configure the parameters of the P(U) curve. Configure the parameters of the P(f) curve. Configure the parameters of the active power limited. Configure the parameters of the active power increasing and decreasing speed.
⑤	Reactive power settings	Choose the reactive power control mode. Configure the parameters of the Q (U) curve. Configure the parameters of the $\cos \varphi$ (P) curve. Configure the parameters of the fix Q value or fix $\cos \varphi$ value.
⑥	Inverter update	Update the firmware of the inverter and monitor device. Update the safety package.

⑦	Power on/off	Remote turn on/off the inverter on the App.
⑧	Energy storage settings	Configure the parameters of the Hybrid inverter. Configure the parameters of the battery.

8.5.2 Grid code settings



For the Australia market, the inverter cannot be connected to the grid before the safety related area is set. Please select from Australia Region A/B/C to comply with AS/NZS 4777.2:2020, and contact your local electricity grid operator on which Region to select.

Normally you only need choose the grid code from the support grid code list. The product has fully complied with the standards that are added in the list. If the local grid operator has the other requirement, you can can set the parameter according to the requirement after you get the approval.

Procedure:

Step 1: Tap “Grid code setting” to enter to the next page.

Step 2: Swipe the smartphone screen to choose the right grid code, then tap “Save” and go back the previous page.

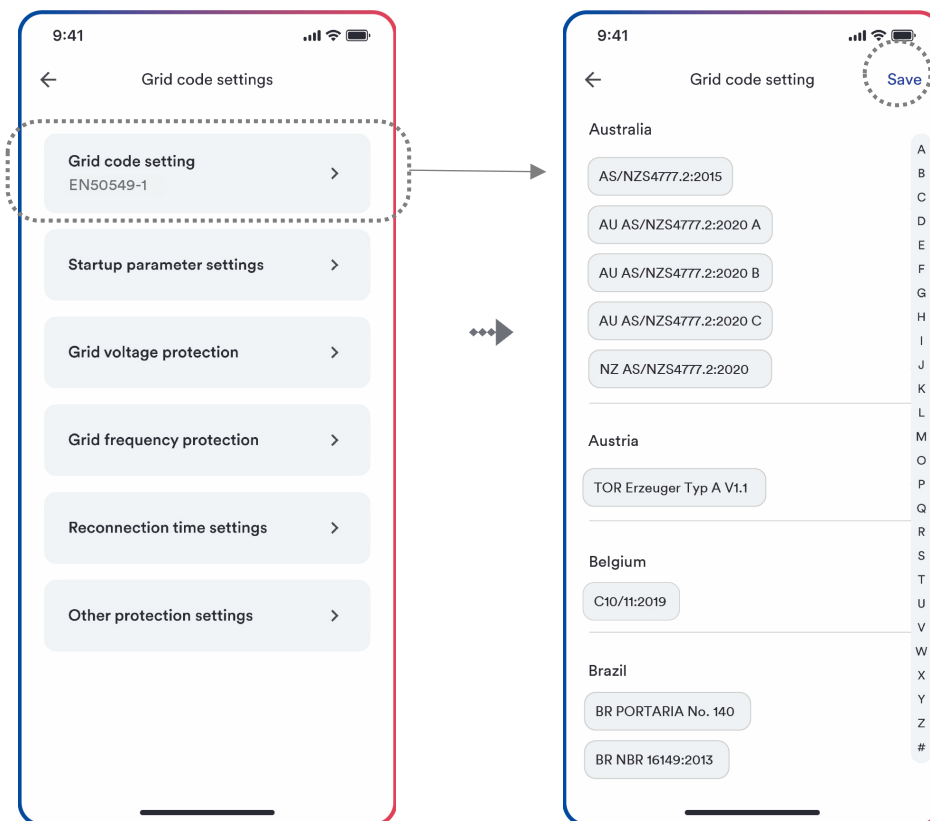

Step 1

Step 2

8.5.3 Active power reduction at overfrequency P(f)

There are four modes (Please refer to the following table) can be chosen for this function and many parameters can be configured according to the requirement of the local grid company.

Procedure:

- Step 1:** Tap “Active power settings” to enter to the next page.
- Step 2:** Tap “Overfrequency response settings” to enter to the next page.
- Step 3:** Tap the drop-down menu to choose the mode of this function.
- Step 4:** Configure the parameters and tap “Save”.

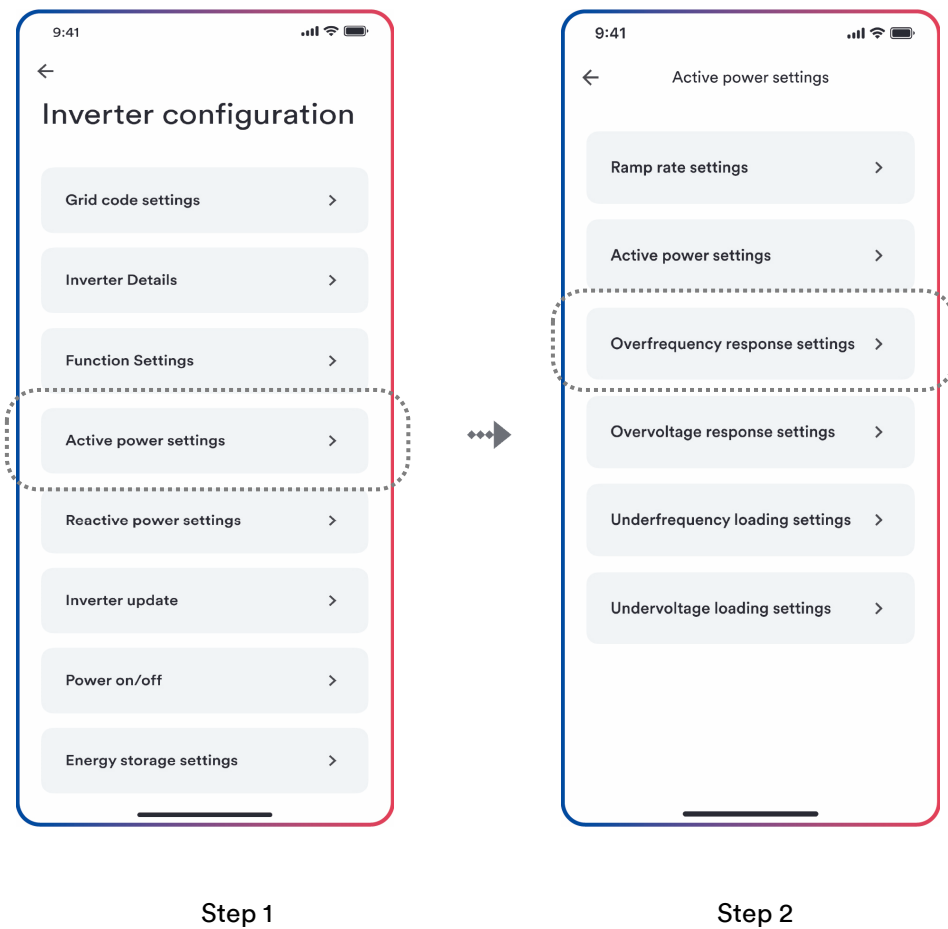

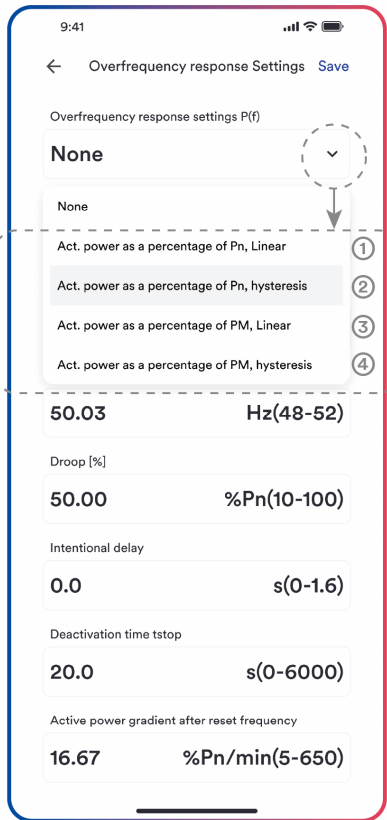

Step 3

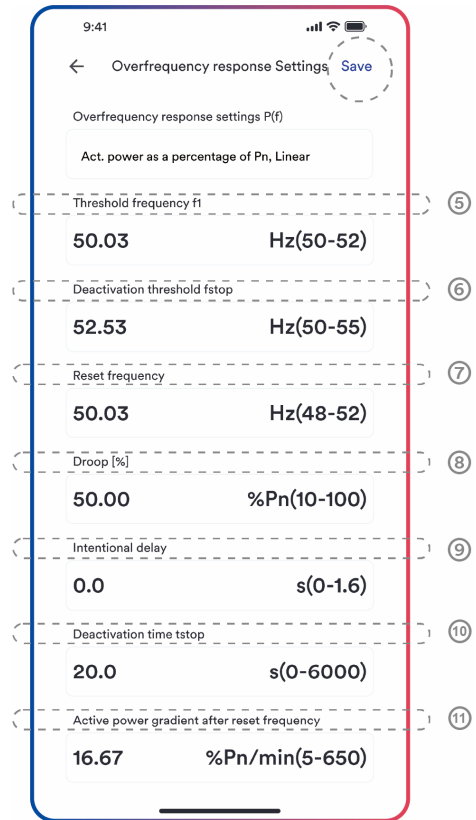

Step 4

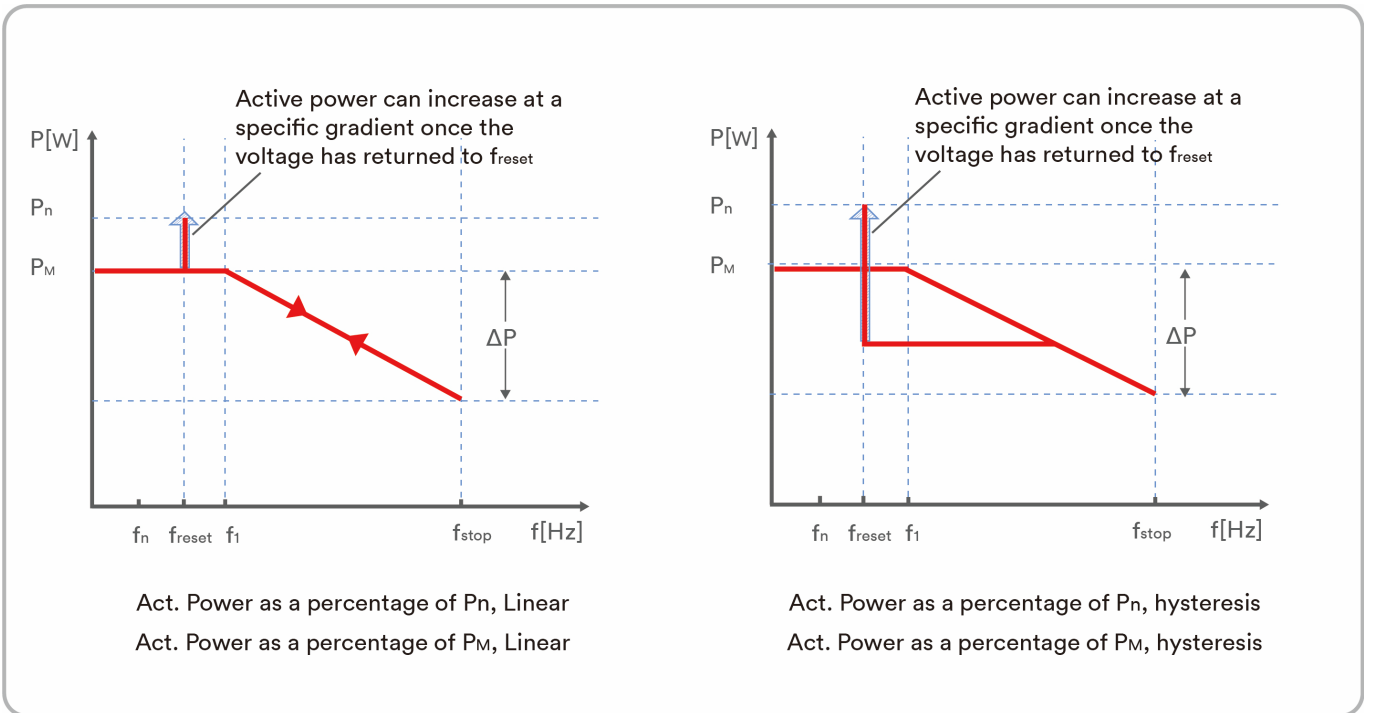

Table description

No.	Name	Description
①	Act. Power as a percentage of P_n , Linear	Droop is defined as the active power as a percentage of P_n . The active power will continuously move up and down the frequency characteristic curve in the frequency range of f_1 to f_{stop} .
②	Act. Power as a percentage of P_n , hysteresis	Droop is defined as the active power as a percentage of P_n . The active power shall remain at or below the lowest power output level reached in response to the increase in frequency between f_1 to f_{stop} .
③	Act. Power as a percentage of P_M , Linear	Droop is defined as the active power as a percentage of P_M . The active power will continuously move up and down the frequency characteristic curve in the frequency range of f_1 to f_{stop} .
④	Act. Power as a percentage of P_M , hysteresis	Droop is defined as the active power as a percentage of P_M . The active power shall remain at or below the lowest power output level reached in response to the increase in frequency between f_1 to f_{stop} .
⑤	Threshold frequency f_1	The threshold frequency for activating active power response to overfrequency.
⑥	Deactivation threshold f_{stop}	The threshold frequency for deactivating the active power response to overfrequency or disconnecting the inverter from the grid.
⑦	Reset frequency f_{reset}	The threshold frequency for deactivating the active power response to overfrequency after the frequency reducing.
⑧	Droop ΔP	Reducing the active power in percentage of P_n or P_M when the frequency rise to f_{stop} .
⑨	Intentional delay time	The delay time for activating active power response to overfrequency after the frequency over f_1 . An intentional delay shall be programmable to adjust the dead time to a value between the intrinsic dead time and 2s.
⑩	Deactivation time t_{stop}	The delay time that the active power can increase after the frequency below f_{reset} .
⑪	Active power gradient	The active power increasing gradient as a percent of P_n per minutes after the frequency reducing to f_{reset} .



Here, the Droop is different from the Droop S in section 3.7.2 of the standard EN 50549-1.

If you want to configure the Droop S, the formula as below should be used to configure.

$$\Delta P = \frac{(f_{\text{stop}} - f_1) / f_n}{\text{Droop S}} \times 100$$

8.5.4 Active power reduction at overvoltage P(U)

There are five modes (Please refer to the following table) can be chosen for this function and many parameters can be configured according to the requirement of the local grid company.

Procedure:

- Step 1:** Tap “Active power settings” to enter to the next page.
- Step 2:** Tap “Overfrequency response settings” to enter to the next page.
- Step 3:** Tap the drop-down menu to choose the mode of this function.
- Step 4:** Configure the parameters and tap “Save”.

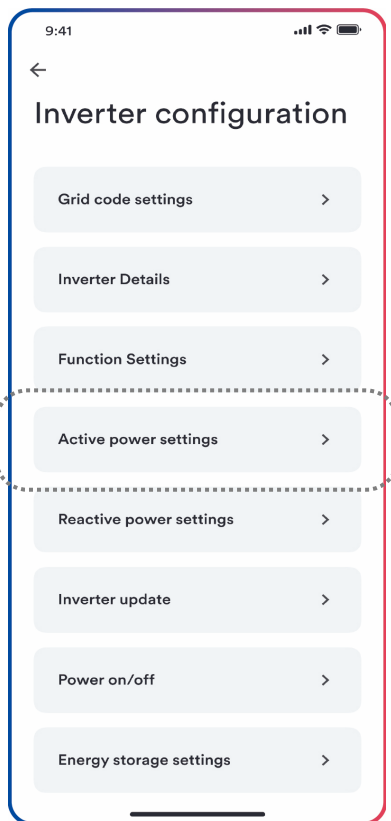

Step 1

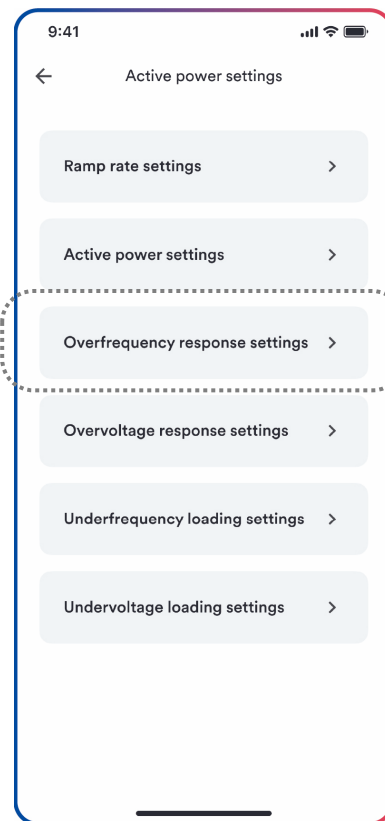

Step 2

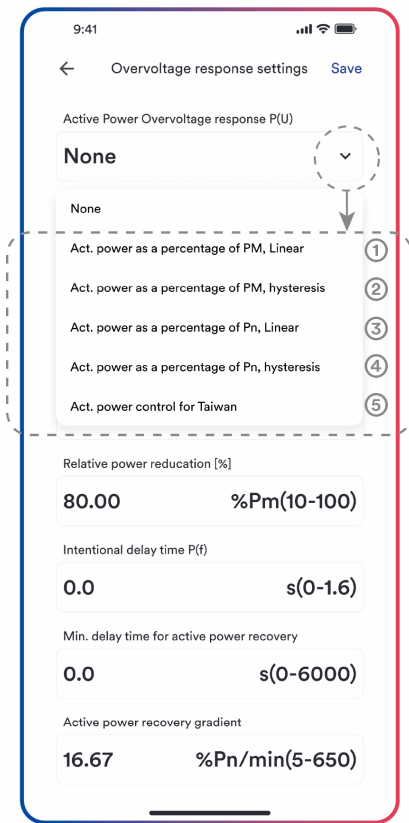

Step 3

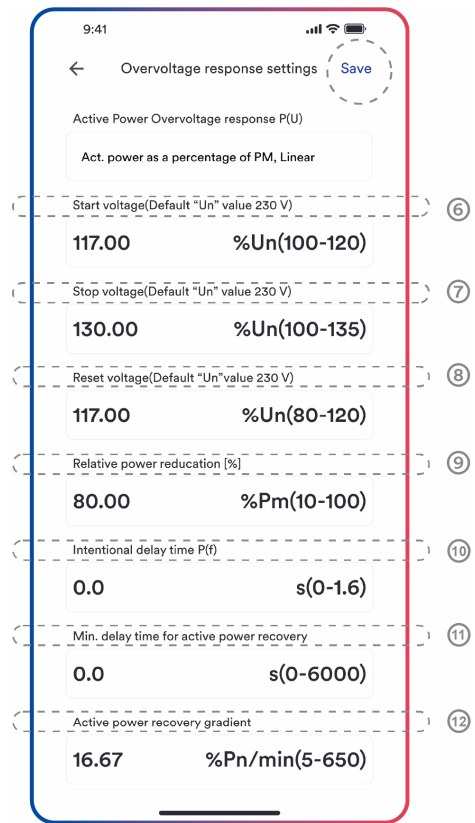

Step 4

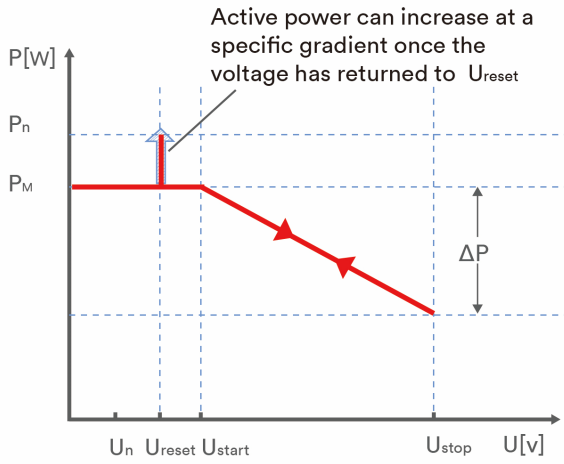

Act. Power as a percentage of P_M , Linear

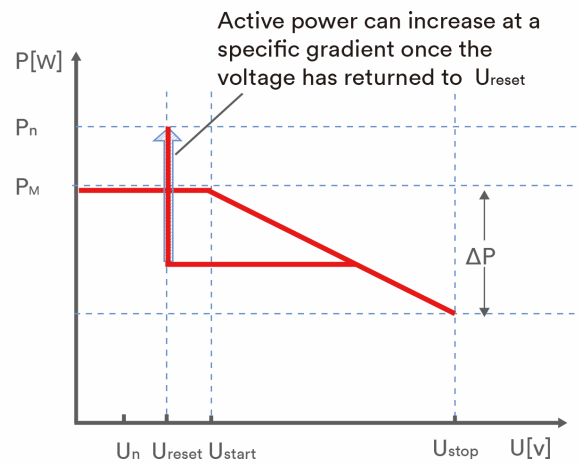

Act. Power as a percentage of P_M , hysteresis

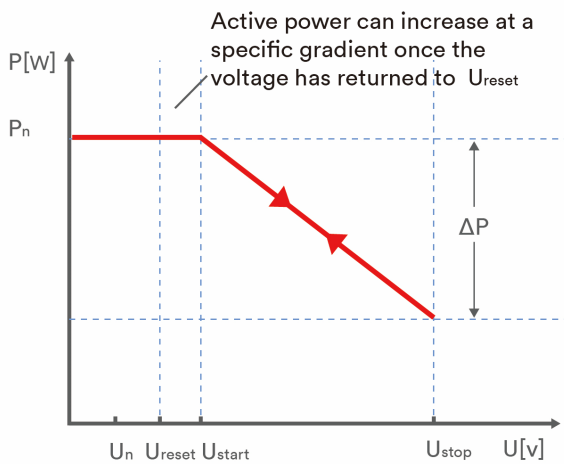

Act. Power as a percentage of P_n , Linear

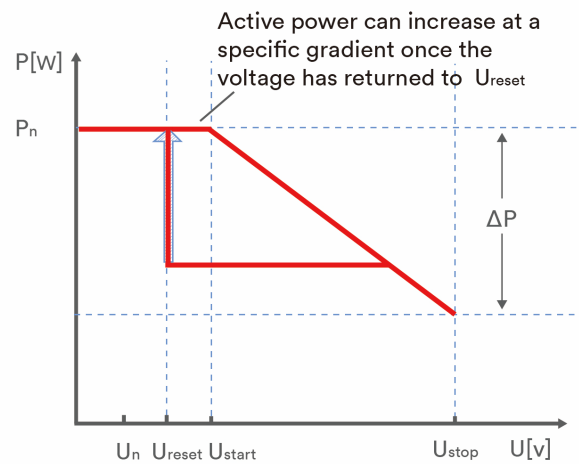

Act. Power as a percentage of P_n , hysteresis

Table description

No.	Name	Description
①	Act. Power as a percentage of P_M , Linear	<p>Droop is defined as the active power as a percentage of P_M.</p> <p>The active power will continuously move up and down the voltage characteristic curve in the voltage range of U_{start} to U_{stop}.</p> <p>The active power reduce from the P_M that is the instantaneous active power at the time of exceeding Start voltage U_{start}.</p>
②	Act. Power as a percentage of P_M , hysteresis	<p>Droop is defined as the active power as a percentage of P_M.</p> <p>The active power shall remain at or below the lowest</p>

		<p>power output level reached in response to the increase in voltage between U_{start} to U_{stop}.</p> <p>The active power reduce from the P_M that is the instantaneous active power at the time of exceeding Start voltage U_{start}.</p>
③	Act. Power as a percentage of P_N , Linear	<p>Droop is defined as the active power as a percentage of P_N.</p> <p>The active power will continuously move up and down the voltage characteristic curve in the voltage range of U_{start} to U_{stop}.</p> <p>The active power reduce from the rated active power P_n at all time. The active power maybe don't reduce if the limited value of the curve is lower than the instantaneous active power at the time of exceeding Start voltage U_{start}.</p>
④	Act. Power as a percentage of P_N , hysteresis	<p>Droop is defined as the active power as a percentage of P_N.</p> <p>The active power shall remain at or below the lowest power output level reached in response to the increase in the voltage range of U_{start} to U_{stop}.</p> <p>The active power reduce from the rated active power P_n at all time. The active power maybe don't reduce if the limited value of the curve is lower than the instantaneous active power at the time of exceeding Start voltage U_{start}.</p>
⑤	Act. Power control for Taiwan	Special control mode for Chinese Taiwan market.
⑥	Start voltage U_{start}	The threshold voltage for activating active power response to overvoltage.
⑦	Stop voltage U_{stop}	The threshold voltage for deactivating the active power response to overvoltage or disconnecting the inverter from the grid.
⑧	Reset voltage U_{reset}	<p>The threshold voltage for deactivating the active power response to overvoltage after the voltage reducing.</p> <p>Reset voltage does not work in the mode "Act. Power as a percentage of P_N, Linear".</p>
⑨	Droop ΔP	Reducing the active power in percentage of P_N or P_M when the voltage rise to U_{stop} .
⑩	Intentional delay time	The delay time for activating active power response to overvoltage after the voltage over U_{start} . An intentional delay shall be programmable to adjust the dead time to a value between the intrinsic dead time and 2s.
⑪	Deactivation time t_{stop}	The delay time that the active power can increase after the voltage below U_{reset} .
⑫	Active power gradient	The active power increasing gradient as a percent of P_n per minutes after the frequency reducing to f_{reset} .

8.5.5 Cosφ(P) curve configuration

The power related control mode cosφ(P) controls the cosφ of the output as a function of the active power output.

There are four coordinate points that can be configured. The coordinate points are the active power as a percentage of P_n and the displacement factor cosφ.

Procedure:

- Step 1:** Tap “Reactive power settings” to enter to the next page.
- Step 2:** Tap “Enable reactive power” to choose the reactive power control mode and tap the left arrow to go back.
- Step 3:** Tap “Cosφ(P) curve settings” to enter to the next page.
- Step 4:** Configure the parameters and tap “Save”.

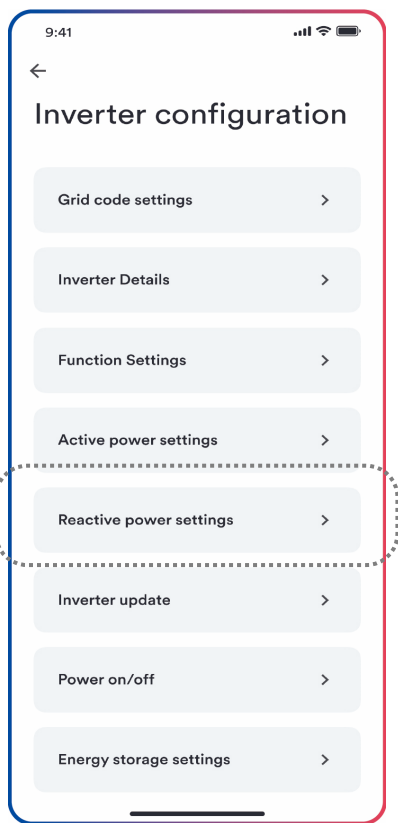

Step 1

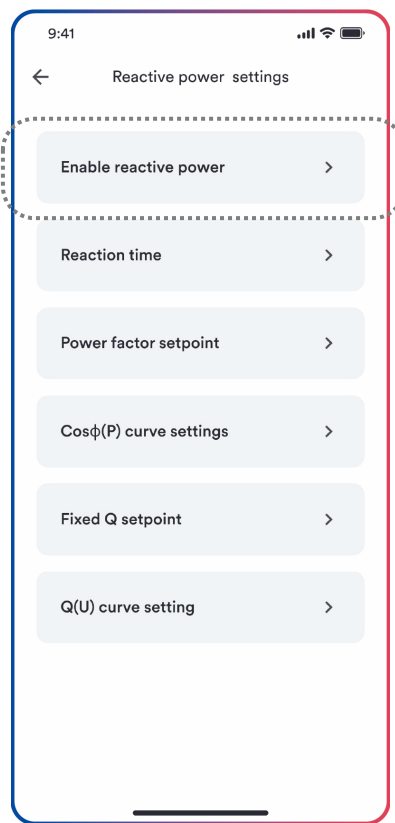

Step 2

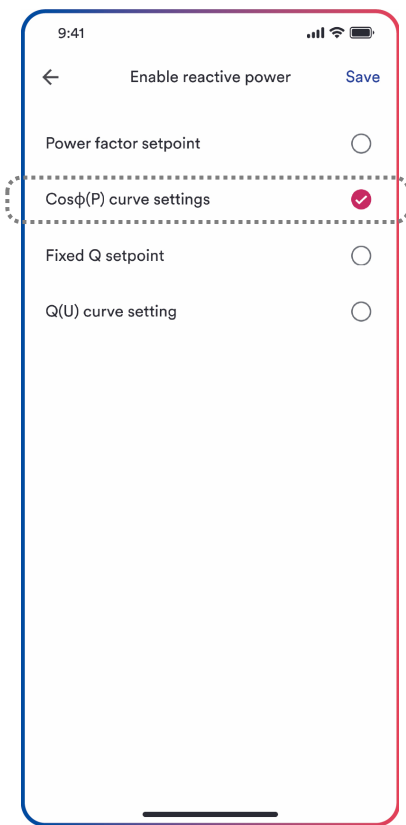

Step 3

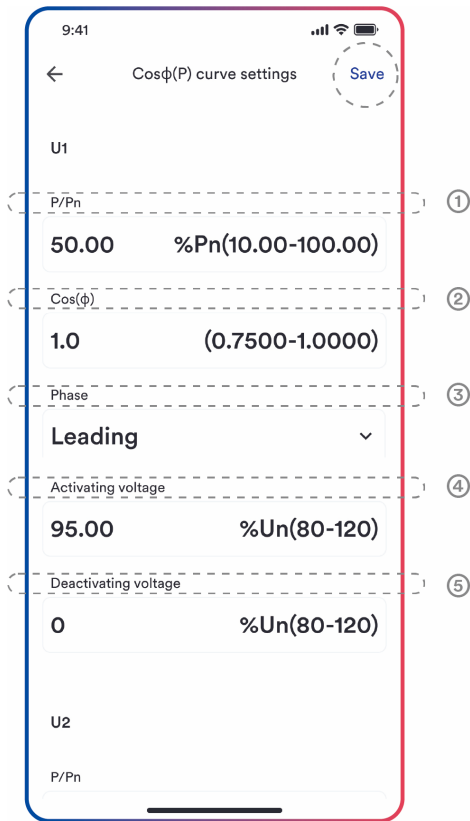

Step 4

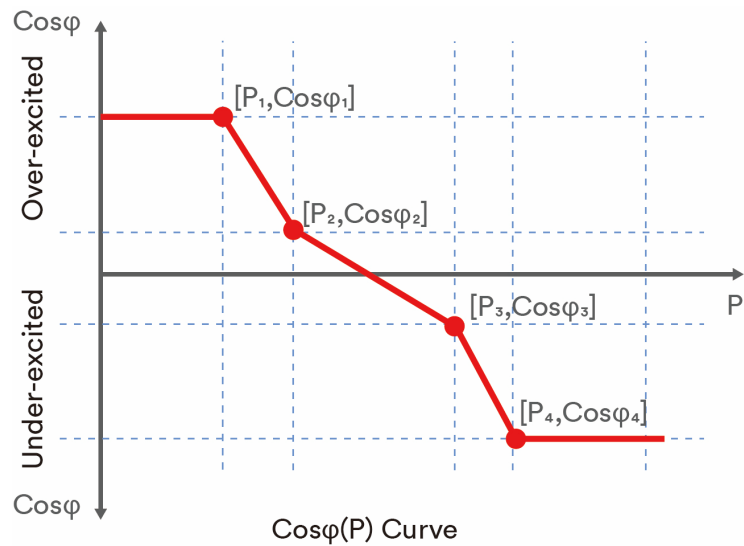

Cosφ(P) Curve

Table description

No.	Parameter	Description
①	P/P _n	The active power as a percentage of P _N .
②	Cosφ	The displacement factor that is cosine of the phase angle between the fundamental components of the line to neutral point voltage and the respective current.
③	Phase	Choose the over-excited or under-excited.

④	Activating voltage	The lock-in voltage value that enables the automatic reactive power delivery mode. Activation threshold as a percentage of U_n corresponds to 'lock-in' voltage.
⑤	Deactivating voltage	The lock-out voltage value that disables the automatic reactive power delivery mode. Deactivation threshold as a percentage of U_n corresponds to 'lock-out' voltage.



Some grid companies maybe requires two voltage thresholds as a percentage of U_n to activate or deactivate the function. The voltage thresholds normally call 'lock-in' and 'lock-out' voltage.

8.5.6 Q(U) curve configuration

The voltage related control mode Q(U) controls the reactive power output as a function of the voltage.

There are four coordinate points that can be configured. The coordinate points are the voltage as a percentage of U_n and the reactive power as a percentage of P_n .

Procedure:

- Step 1:** Tap "Reactive power settings" to enter to the next page.
- Step 2:** Tap "Enable reactive power" to choose the reactive power control mode and tap the left arrow to go back.
- Step 3:** Tap "Q(U) curve settings" to enter to the next page.
- Step 4:** Configure the parameters and tap "Save".

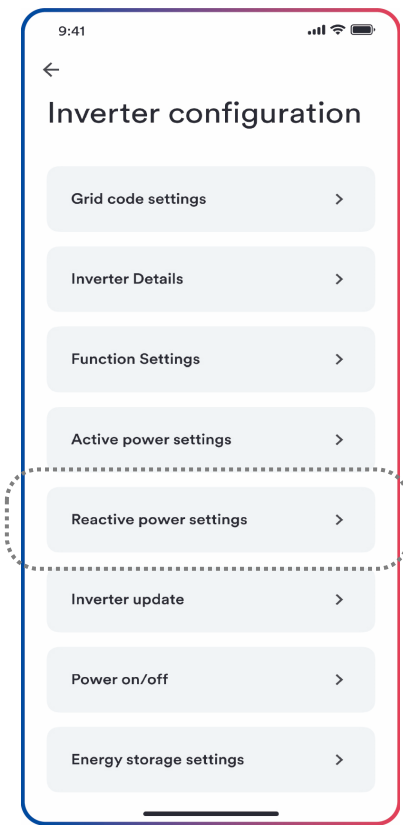

Step 1

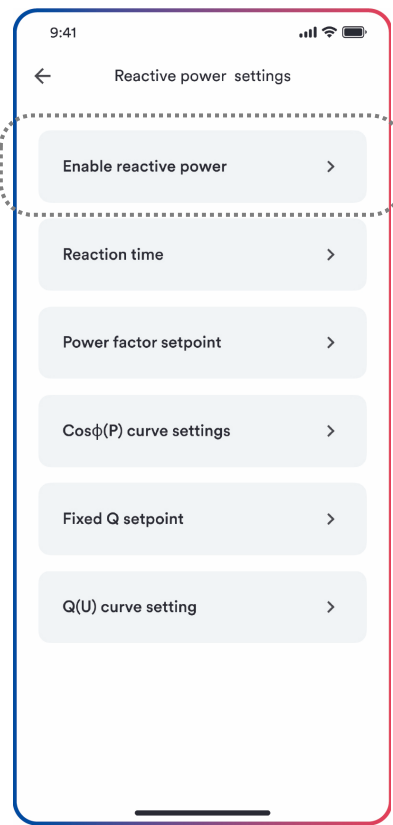

Step 2

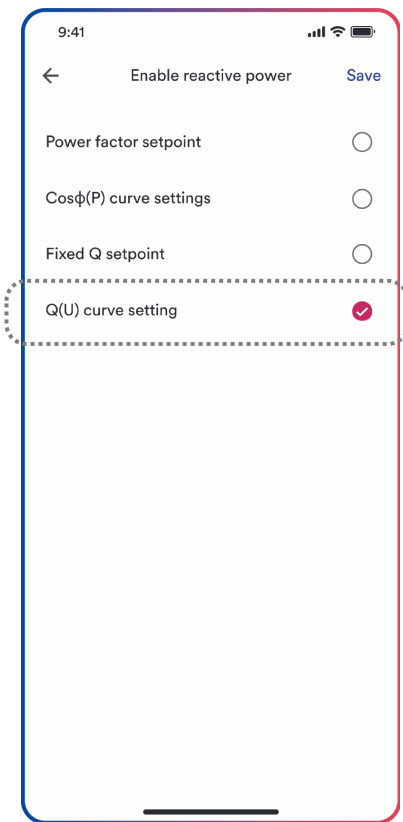

Step 3

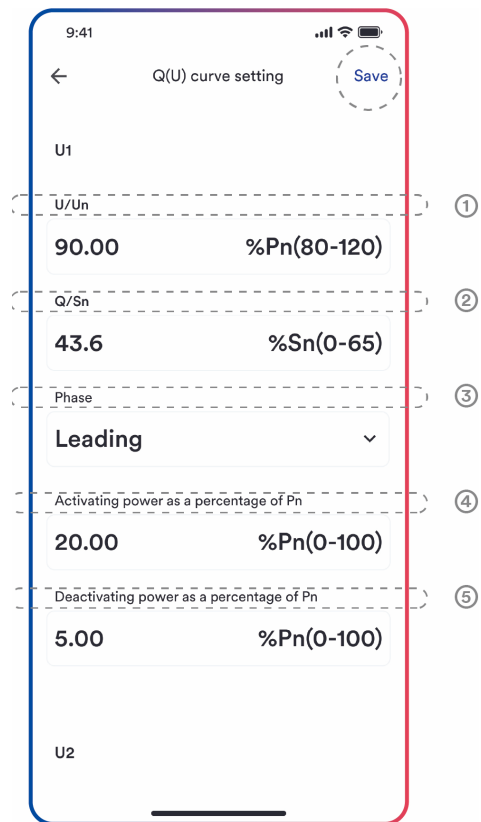

Step 4

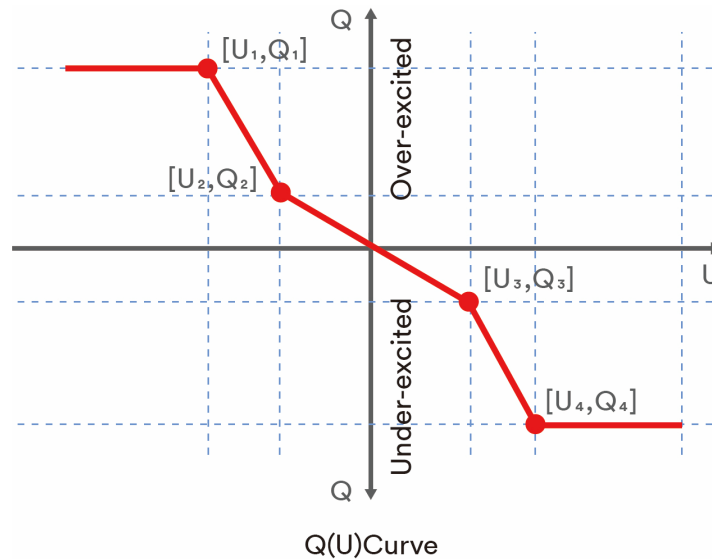

Table description

No.	Name	Description
①	U/U_n	The voltage as a percentage of U_n .
②	Q/P_n	The reactive power as a percentage of P_n .
③	Phase	Choose the over-excited or under-excited.
④	Activating power as a percentage of P_n	The lock-in active power value that enables the automatic reactive power delivery mode. Activation threshold as a percentage of P_n corresponds to 'lock-in' power.
⑤	Deactivating power as a percentage of P_n	The lock-out active power value that disables the automatic reactive power delivery mode. Deactivation threshold as a percentage of P_n corresponds to 'lock-out' power.



Some grid companies maybe requires two active power thresholds as a percentage of P_n to activate or deactivate the function. The active power thresholds normally call 'lock-in' and 'lock-out' active power.

9 Decommissioning the product

9.1 Disconnecting the inverter from voltage sources

Prior to performing any work on the product, always disconnect it from all voltage sources as described in this section. Always adhere to the prescribed sequence.

WARNING

Danger to life due to electric shock from destruction of the measuring device due to overvoltage !

Overvoltage can damage a measuring device and result in voltage being present in the enclosure of the measuring device. Touching the live enclosure of the measuring device results in death or lethal injuries due to electric shock.

- Only use measuring devices with a DC input voltage range of 1100 V or higher.

Procedure:

Step 1: Disconnect the miniature circuit breaker and secure against reconnection.

Step 2: Disconnect the DC switch and secure against reconnection.

Step 3: Wait until the LEDs have gone out.

Step 4: Use a current clamp meter to ensure that no current is present in the DC cables.

DANGER

Danger to life due to electric shock when touching exposed DC conductors or DC plug contacts if the DC connectors are damaged or loose !

The DC connectors can break or become damaged, become free of the DC cables, or no longer be connected correctly if the DC connectors are released and disconnected incorrectly. This can result in the DC conductors or DC plug contacts being exposed. Touching live DC conductors or DC plug connectors will result in death or serious injury due to electric shock.

- Wear insulated gloves and use insulated tools when working on the DC connectors.
- Ensure that the DC connectors are in perfect condition and that none of the DC conductors or DC plug contacts are exposed.
- Carefully release and remove the DC connectors as described in the following.

Step 5: Loosen and remove the DC connector.

Type 1 DC connector

Release and remove the DC connectors. To do so, insert a flat-blade screwdriver or an angled screwdriver (blade width: 3.5mm) into one of the side slots and pull the DC connectors out.

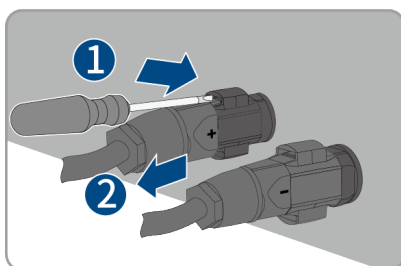

Type 2 DC connector

To remove DC plug connectors, insert a wrench tool into the slots and press the wrench tool with an appropriate force.

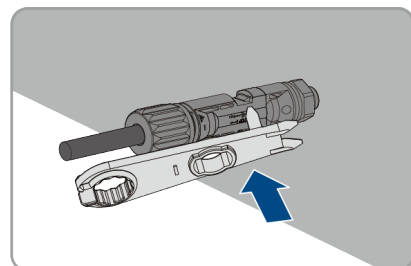

Step 6: Ensure that no voltage is present between the positive terminal and negative terminal at the DC inputs using a suitable measuring device.

Step 7: Loosen and remove the Grid connector.

Unlock instructions

① Rotate the latch as shown.

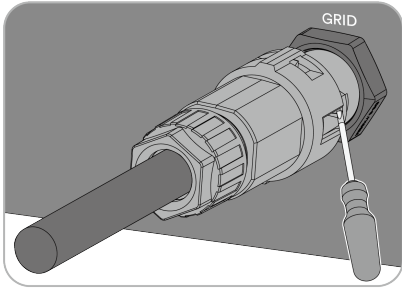

② Remove the female end of the cable to unlock the account.

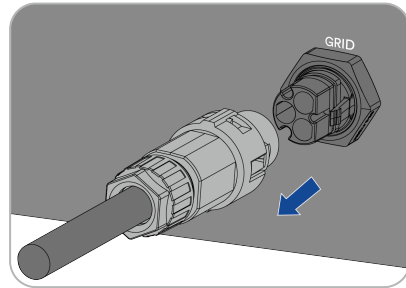

Step 8: Loosen and remove the EPS Load connector.

Unlock instructions

① Rotate the latch as shown.

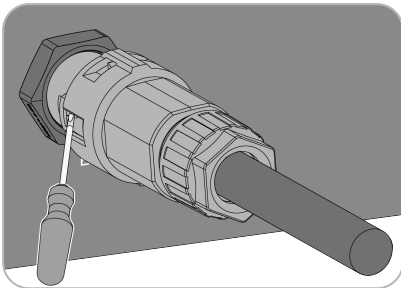

② Remove the female end of the cable to unlock the account.

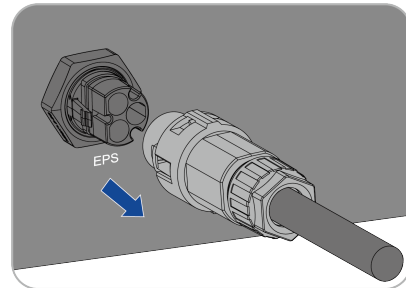

Step 9: Loosen and remove the Battery connector.

Unlock instructions

① Unscrew the battery terminal cover.

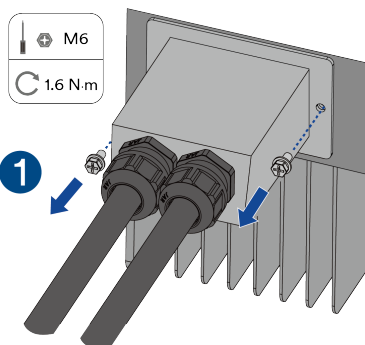

② Use a screwdriver to loosen the lugs on the socket and pull apart the battery terminals.

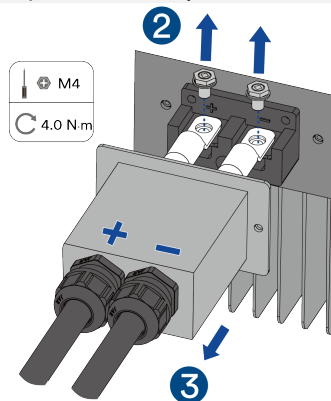

Step 10: Hold down the buckle on the side of the Ai-Dongle and pull out the Ai-Dongle terminal.

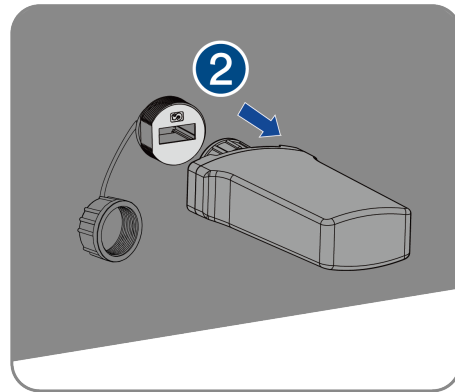
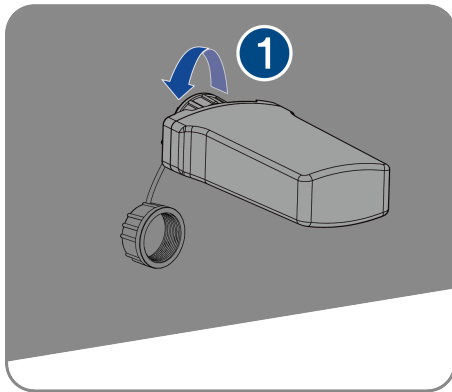

9.2 Dismantling the inverter

After disconnecting all electrical connections as described in Section 9.1, the inverter can be removed as follows

Procedure:

- Step 1:** Dismantle the inverter referring to “5.3 Mounting” in reverse steps.
- Step 2:** If necessary, remove the wall-mounting bracket from the wall.
- Step 3:** If the inverter will be reinstalled in the future, please refer to “3.2 Product Storage” for a proper conservation.

10 Technical data

10.1 ASW3000H/3680H/4000H/5000H/6000H-S2

Type	ASW3000H-S2	ASW3680H-S2	ASW4000H-S2	ASW5000H-S2	ASW6000H-S2
DC Input					
Maximum power of PV array	5500 Wp	6180 Wp	6500 Wp	7500 Wp	9000 Wp
Max. power per MPP tracker	3420 Wp	3820 Wp	4020 Wp	4600 Wp	4600 Wp
Maximum input voltage	550 V				
Rated input voltage	380 V				
Minimum input voltage	40 V				
Start voltage	50 V				
MPP voltage range	40-530 V				
MPP voltage range at Pnom	200~530 V				
Max. input current	16 A				
Isc PV (absolute maximum)	20 A				
Maximum reverse current into the PV modules	0 A				
Number of independent MPP inputs	2				
Strings per MPP input	PV1, PV2				
Overvoltage category in accordance with ICE 60664-1	II				
AC Input and Output					
Rated output power at 230 V	3000W	3680W	4000W	5000W	6000W
Rated apparent power at $\cos\varphi = 1$	3000VA	3680VA	4000VA	5000VA	6000VA
Maximum apparent power at $\cos\varphi = 1$	3000VA	3680VA	4000VA	5000VA	6000VA
Rated grid voltage	220V,230V				
Grid voltage range	160V-300V				
Rated grid frequency	50 Hz/60 Hz				
Grid frequency range	45-55 Hz/55-65 Hz				
Rated output current at 220 V	13.6 A	16.7 A	18.1 A	22.7 A	27.2 A
Rated output current at 230 V	13.1 A	16 A	17.4 A	21.7 A	26.1 A
Rated output current at 240 V	12.5 A	15.3 A	16.6 A	20.8 A	25 A
Maximum output current	13.6A	16 A	18.2 A	22.7 A	27.3A
Max. input power from grid	6000 VA	6000 VA	6000 VA	6000 VA	6000 VA
Max. input current from grid	27.3 A	27.3 A	27.3 A	27.3 A	27.3 A
Inrush current	10A/250us				
Contribution to peak short-circuit current ip	73 A				
Initial short-circuit alternating current (Ik" first single period effective value)	13.6A	16 A	18.2 A	22.7 A	27.3A
Short circuit current continuous [ms] (max output fault current)	13.6A	16 A	18.2 A	22.7 A	27.3A
Recommended rated current of AC circuit Breaker	50 A	50 A	50 A	50 A	50 A
Total harmonic distortion of the output current with total harmonic distortion of the AC voltage <2%, and AC power >50% of the rated power	<3% (of nominal power)				
Adjustable displacement power factor	0.8 leading to 0.8 lagging				

Overvoltage category in accordance with IEC 60664-1	III				
Efficiency					
Maximum efficiency	96.8%	96.8%	96.8%	96.8%	96.8%
European weighted efficiency	95.6%	95.6%	96.1%	96.3%	96.4%
Battery data					
Max charging power	5000 W				
Max discharging power	5000 W				
Battery voltage range	40~60 V				
Max charging current	100 A				
Max discharging current	100 A				
Rated charging current	100 A				
Rated discharging current	100 A				
Battery type	LiFePO4				
EPS load data					
Rated apparent power at 230V	5000 W	5000 W	5000 W	5000 W	5000 W
Max. apparent power at 230V, continuous on-grid	5500 VA	5500 VA	5500 VA	5500 VA	5500 VA
Max. apparent power at 230V continuous off-grid	5500 VA	5500 VA	5500 VA	5500 VA	5500 VA
Max. apparent power at at 230V, off-grid <10s	7500 VA	7500 VA	7500 VA	7500 VA	7500 VA
Max. power on each phase at 230V, continuous on-grid	/	/	/	/	/
Max. power on each phase at 230V, continuous off-grid	/	/	/	/	/
Nominal output voltage	230V				
AC grid frequency	50 Hz / 60 Hz				
Max. continuous output current	23.9 A	23.9 A	23.9 A	23.9 A	23.9 A
Max. output current <10s	32.6 A	32.6 A	32.6 A	32.6 A	32.6 A
Rated current at 230V	21.7 A	21.7 A	21.7 A	21.7 A	21.7 A
Max. current at 230V, continuous on-grid	23.9 A	23.9 A	23.9 A	23.9 A	23.9 A
Max. current at 230V, continuous off-grid	23.9 A	23.9 A	23.9 A	23.9 A	23.9 A
Total harmonic distortion (THDv, linear load)	3%				
Switching time to battery-backup operation	<10 ms				

(1) The voltage range meets the requirements of the corresponding national grid code.

(2) The frequency range meets the requirements of the corresponding national grid code.

10.2 General data

Type	ASW3000H-S2 / 3680H-S2 / 4000H-S2 / 5000H-S2 / 6000H-S2
Width × height × depth	483 x 455 x 193.5 mm
Weight	25.1kg
Topology	Non-isolated
Operating temperature range	-25°C ... +60°C
Allowable relative humidity range (non-condensing)	0% ... 100%
Degree of protection for electronics in accordance with IEC 60529	IP66

Climatic category in accordance with IEC 60721-3-4	4K4H
Protection class (according to IEC 62103)	I/II(DC), III(AC)
Pollution degree outside the enclosure	3
Pollution degree inside the enclosure	2
Max. operating altitude above mean sea level	4000 m (>3000 m derating)
Self-consumption (night)	<10W
Cooling method	Natural convection
Typical noise emission	< 25 dB(A)@1m
Display	LED indicator, App
Demand response mode in accordance with AS/NZS 4777.2	DRM0
Export active power output	Via connecting Smart meter
Earth Fault Alarm	cloud based, Visible
Interfaces	RS485, WiFi stick
Communication	ModBus RTU and CAN
Mounting information	Wall mounting bracket
Radio technology	WLAN 802.11 b/g/n
Radio spectrum	WLAN with 2412 – 2472MHz band
Maximum transmission power	100 mW

10.3 Protective device

Protective devices	ASW3000H-S2 / 3680H-S2 / 4000H-S2 / 5000H-S2 / 6000H-S2
DC reverse polarity protection	Integrated
DC isolator	Integrated
Ground fault monitoring	Integrated
AC short- circuit current capability	Integrated
Active anti-islanding protection	Integrated
PV string current monitoring	Integrated
DC current injection monitoring	Integrated
Low voltage ride through	Integrated
High voltage ride through	Integrated
Overvoltage protection	DC Type II / AC Type III

11 Troubleshooting

When the PV system does not operate normally, we recommend the following solutions for quick troubleshooting. If an error or warning occurs, there will have "Event Messages" display in the monitor tools. The corresponding corrective measures are as follows:

Error code	Message	Corrective measures
3	Relay check Fail	<ul style="list-style-type: none"> • Check the DC side condition (e.g. input voltage, poor contact, etc.) and remove any abnormality. • Disconnect EPS to check grid condition(e.g. voltage, frequency, poor condition,etc) and remove any abnormality, then restart it to check if the fault is disappear; • Make exchange of the inverter if complete the above guide with fault is still there.
4	DC Injection High	<ul style="list-style-type: none"> • Check DCI protection limit and adjust it to be 2A to observe is the fault disappear? • If the fault is still there, Check the grid condition(e.g., voltage, frequency, poor contact, etc.) • Test the surrounding environment for the presence of high-power equipment (e.g., generators, cranes, etc.), this fault may be related to the start and stop of this equipment. • Make exchange of the inverter if complete the above guide with fault is still there.
5	The result of Auto Test Function is fail	<ul style="list-style-type: none"> • Disconnect the inverter from the AC grid, PV module and battery and reconnect after 5 minutes. • Make exchange of the inverter if complete the above guide with fault is still there.
8	AC HCT Failure	<ul style="list-style-type: none"> • Disconnect the inverter from the AC grid, PV module and battery and reconnect after 5 minutes. • Make exchange of the inverter if complete the above guide with fault is still there.
9	GFCI Device Failure	<ul style="list-style-type: none"> • Disconnect the inverter from the AC grid, PV module and battery and reconnect after 5 minutes. • Make exchange of the inverter if complete the above guide with fault is still there.
10	Device fault	<ul style="list-style-type: none"> • Disconnect the inverter from the AC grid, PV module and battery and reconnect after 5 minutes. • If this fault is still being shown, contact the service. • The inverter temperature should be above -40°C
12	HW output over current	<ul style="list-style-type: none"> • Disconnect the inverter from the AC grid, PV module, battery and reconnect after 5 minutes, check is it solved? • If not, disconnect the load, and restart the inverter to check is it solved? • If the fault disappear, then connect the load one by one to check which load

		<p>result this fault?</p> <ul style="list-style-type: none"> • Make exchange of the inverter if complete the above guide with fault is still there.
33	Fac Failure:Fac Out of Range	<ul style="list-style-type: none"> • Check the grid and EPS frequency and observe how often major fluctuations occur. • Contact customer service if EPS frequency abnormal. If this fault is caused by frequent fluctuations, try to modify the operating parameters after informing the grid operator first.
34	AC Voltage Out of Range	<ul style="list-style-type: none"> • Check the grid voltage and grid connection on inverter. • Check the grid voltage at the point of connection of inverter. If the grid voltage is outside the permissible range due to local grid conditions, try to modify the values of the monitored operational limits after informing the electric utility company first. If the grid voltage lies within the permitted range and this fault still occurs, please call service.
36	GFCI Failure	<p>Make sure the inverter is reliably grounded.</p> <ul style="list-style-type: none"> • Only Disconnect PV module and restart it to check is the fault on? Remove any abnormality. • Only Disconnect battery to check is the fault on? Remove any abnormality. • Only Disconnect Grid side to check is fault on? Remove any abnormality. • Disconnect EPS to check is fault on? Remove any abnormality.
37	PV Over Voltage	<ul style="list-style-type: none"> • Check the open-circuit voltages of the strings and make sure it is below the maximum DC input voltage of the inverter. • Make exchange of the inverter if the input voltage lies within the permitted range and the fault still occurs.
38	Isolation Fault	<p>Make sure the inverter is reliably grounded.</p> <ul style="list-style-type: none"> • Only Disconnect PV module and restart it to check is the fault on? Remove any abnormality. • Only Disconnect battery to check is the fault on? remove any abnormality. • Only Disconnect Grid side to check is fault on? remove any abnormality. • Disconnect EPS to check is fault on? remove any abnormality.
40	Over temperature in inverter	<ul style="list-style-type: none"> • Check whether the airflow to the heat sink is obstructed. • Check whether the ambient temperature around the inverter is too high.
48	Average volt of ten minutes Fault	<ul style="list-style-type: none"> • Check the grid voltage at the point of connection of inverter. If the grid voltage is outside the permissible range due to local grid conditions, try to modify the values of the monitored operational limits after informing the electric utility company first. • If the grid voltage lies within the permitted range and this fault still occurs, please call service.
70	AFCI Self Test Fail	<ul style="list-style-type: none"> • Make exchange of the inverter.
71	AFCI Fault	<ul style="list-style-type: none"> • Disconnect each MPPT tracker, and eliminate any abnormalities. • Make exchange of the inverter if complete the above guide with fault is still

Warning Code	Message	Corrective measures
		there.
34	PV1 input over current-software	<ul style="list-style-type: none"> • Disconnect the inverter from the AC grid, PV module and battery, and reconnect after 5 minutes to check is the problem solved? • Make exchange of the inverter if complete the above guide with fault is still there.
35	PV1 input over current-hardware	<ul style="list-style-type: none"> • Disconnect the inverter from the AC grid, PV module and battery, and reconnect after 5 minutes to check is the problem solved? • Make exchange of the inverter if complete the above guide with fault is still there.
36	PV2 input over current-software	<ul style="list-style-type: none"> • Disconnect the inverter from the AC grid, PV module and battery, and reconnect after 5 minutes to check is the problem solved? • Make exchange of the inverter if complete the above guide with fault is still there.
37	PV2 input over current-hardware	<ul style="list-style-type: none"> • Disconnect the inverter from the AC grid, PV module and battery, and reconnect after 5 minutes to check is the problem solved? • Make exchange of the inverter if complete the above guide with fault is still there.
38	PV3 input over current-software	<ul style="list-style-type: none"> • Disconnect the inverter from the AC grid, PV module and battery, and reconnect after 5 minutes to check is the problem solved? • Make exchange of the inverter if complete the above guide with fault is still there.
39	PV3 input over current-hardware	<ul style="list-style-type: none"> • Disconnect the inverter from the AC grid, PV module and battery, and reconnect after 5 minutes to check is the problem solved? • Make exchange of the inverter if complete the above guide with fault is still there.
40	BUS over voltage-software	<ul style="list-style-type: none"> • Check actual PV input voltage & AC voltage to make sure the voltage within the voltage range when installing the inverter; • If the fault reports during the inverter first installation, and also doesn't work for more than 6 months after production, then the fault may be caused by energy lack of capacitance. Then close the DC switch to charge the capacitor for one day to check is the problem solved? Make exchange of the inverter if it is not solved. Go to next steps to check when it is not new installation • Check BUS voltage in cloud; • If BUS voltage is over 1050V when PV input voltage is most same with 1000V, please decrease input voltage to check is the fault disappear? • If BUS voltage is over 1050V when PV input voltage is most less than 1000V, Make exchange of the inverter.
42	BUS voltage unbalance(for	<ul style="list-style-type: none"> • Check actual PV input voltage & AC voltage to make sure the voltage within

	three phase inverter)	<p>the voltage range when installing the inverter;</p> <ul style="list-style-type: none"> • If the fault reports during the inverter first installation, and also doesn't work for more than 6 months after production, then the fault may be caused by energy lack of capacitance. Then close the DC switch to charge the capacitor for one day to check is the problem solved? Make exchange of the inverter if it is not solved. • Go to next steps to check when it is not new installation • Check BUS voltage in cloud; • If BUS voltage is over 1050V when PV input voltage is most same with 1000V, please decrease input voltage to check is the fault disappear? • If BUS voltage is over 1050V when PV input voltage is most less than 1000V, Make exchange of the inverter.
46	output over current-hardware	<ul style="list-style-type: none"> • Disconnect load to check is the warning still on? and remove any abnormality • Disconnect battery to check is the warning still on? and remove any abnormality • Disconnect PV module to check is the warning still on? and remove any abnormality • Make exchange of the inverter if complete the above guide with fault is still there.
47	Anti-islanding	<ul style="list-style-type: none"> • This warning may occurs when grid frequency or voltage instant un-stable or grid blackout occasionally. • If this warning occurs frequently, contact service.
150	SPD Damaged	<ul style="list-style-type: none"> • Not Applicable now, depends on IBC requirement
162	DC offset current abnormal	<ul style="list-style-type: none"> • Disconnect the inverter from the AC grid, PV module and battery and reconnect after 5 minutes. • Make exchange of the inverter if complete the above guide with fault is still there.
175	Battery Soc Low	<ul style="list-style-type: none"> • Timely charge the battery, observe SOC value, it is normal if SOC value increases steadily. • if SOC value increases uneven, first charge the battery to be full, then make discharge of battery, it can explain battery package is normal when SOC value changing is even, or please make at least one time cycle of full charge and full discharge everyday to observe whether SOC value display is improved. • If the failure cannot be solved, please contact the service.
176	Battery Fault Status	<ul style="list-style-type: none"> • Check battery status in App; • Follow battery status to find battery fault troubleshooting.
178	EPS Output Over	<ul style="list-style-type: none"> • Decrease the load connection to check is this fault disappear? • Stop the inverter and restart with no EPS to check is this fault disappear? • Make exchange of the inverter if complete the above guide with fault is still there.

180	PV string inverse	<ul style="list-style-type: none"> Check PV string/Battery positive and negative connection.
-----	-------------------	---

Warning Code	Battery error status details in App	Corrective measures
W176 Battery Error	Communication data	<ul style="list-style-type: none"> Make inspection of the communication wiring loosen or abnormal between battery package and inverter. To supply power to the inverter through connecting inverter with the grid or PV. If the failure cannot be solved, please contact the service.
	Cell or module overvoltage	<ul style="list-style-type: none"> Stop charging; Make discharging of battery; Observe after multiple cycles of charging&discharging; If the failure cannot be solved, please contact the service.
	Undervoltage of battery cells or modules	<ul style="list-style-type: none"> Stop discharging; Make charging of battery; Observe after multiple cycles of charging&discharging; If the failure cannot be solved, please contact the service.
	Cell temperature too high	<ul style="list-style-type: none"> Stop working; Observe site ambience, is ambience temperature high? Check recent running condition, whether put it in rather high temperature ambience when not put it to work. Wait to recover automatically.
	Cell temperature too low	<ul style="list-style-type: none"> Stop working; Observe site ambience, is ambience temperature too low? Check recent running condition, whether put it in rather low temperature ambience when not put it to work. Wait it to recover automatically.
	Discharge overcurrent	<ul style="list-style-type: none"> Wait it to recover automatically. Check external load connection status of battery package, check does the inverter work normally when only connects with inverter? If the failure cannot be solved, please contact the service.
	Charging overcurrent	<ul style="list-style-type: none"> Wait it to recover automatically. Check charging status of battery package, check does the inverter work normally when only connects with one inverter? If the failure cannot be solved, please contact the service.
	Internal communication error	<ul style="list-style-type: none"> Restart battery equipment, check whether connection plug loosen, whether the connection screw is tighten between the pile battery package and control box; If the failure cannot be solved, please contact the service.
	Cell imbalance	<ul style="list-style-type: none"> Make at least one time cycle of charge&discharge everyday to make battery package balance mechanism. If the failure cannot be solved or improved after one week, please contact the service.

Low system insulation	<ul style="list-style-type: none"> • Confirm if there is any leakage or short circuit between the positive and negative terminals of the battery; • When insulation failure occurs, it is generally necessary to replace the faulty battery pack inside the battery; • If multiple insulation faults occur, it may be necessary to replace the entire battery.
Voltage sensor failure	<ul style="list-style-type: none"> • Test is the connection screw tighten between battery pack and control box? restart battery pack. • If the failure cannot be solved, please contact the service.
Temperature sensor failure	<ul style="list-style-type: none"> • Test is the connection screw tighten between battery pack and control box? restart battery pack. • If the failure cannot be solved, please contact the service.
Contactors failure	<ul style="list-style-type: none"> • Hardware is defective, restart battery and check is the wiring cable loosen? • If the failure cannot be solved, please contact the service.
Power-on self-test failure	<ul style="list-style-type: none"> • Restart Battery; • If the failure cannot be solved, please contact the service.
IC self test failure	<ul style="list-style-type: none"> • Restart Battery; • If the failure cannot be solved, please contact the service.

Contact the service if you meet other problems not in the table.

12 Maintenance

12.1 Cleaning the contacts of the DC switch

DANGER

High voltage of PV string may cause life danger!

If the DC connector is disconnected while the PV inverter is working, electric arc may occur, causing electric shock and burns.

- Please disconnect the circuit breaker on the AC side first, and then disconnect the DC switch.

To ensure the normal operation of the DC input switch, it is necessary to clean the DC switch contacts every year.

Procedure:

Step 1: Disconnect the AC disconnecter and prevent accidental restart.

Step 2: Rotate the DC switch handle from the “ON” position to the “OFF” position for 5 times.

12.2 Cleaning air inlet and outlet

CAUTION

Hot enclosure or heat sink may cause personal injury!

When the inverter is working, the temperature of the enclosure or heat sink will be higher than 70°C, and the contact may cause burns.

- Before cleaning the air outlet, shut down the machine and wait for about 30 minutes until the temperature of the enclosure decreases to normal temperature.

A huge amount of heat is generated in the process of running the inverter. The inverter adopts a controlled forced-air cooling method. In order to maintain good ventilation, please check to make sure the air inlet and outlet are not blocked.

Procedure:

Step 1: Disconnect the AC side circuit breaker and ensure that it cannot be accidentally reconnected.

Step 2: Disconnect the DC switch, rotate the DC switch handle from the “ON” position to the “OFF” position.

Step 3: Clean the air inlet and outlet of the inverter with a soft brush.

13 Recycling and disposal

Dispose of the packaging and replaced parts according to the rules applicable in the country where the device is installed.



Do not dispose of the product together with the household waste but in accordance with the disposal regulations for electronic waste applicable at the installation site.

14 EU declaration of conformity

Within the scope of the EU directives

- Radio Equipment Directive 2014/53/EU (L 153/62-106. May 22. 2014) (RED)
- Restriction of the use of certain hazardous substances 2011/65/EU (L 174/88, June 8, 2011) and 2015/863/EU (L 137/10, March 31, 2015) (RoHS)



AISWEI Technology Co., Ltd. confirms herewith that the inverters described in this manual are in compliance with the fundamental requirements and other relevant provisions of the above mentioned directives.

The entire EU Declaration of Conformity can be found at www.solplanet.net.

15 Service and warranty

If you have any technical problems concerning our products, please contact Solplanet service. We require the following information in order to provide you with the necessary assistance:

- Inverter device type
- Inverter serial number
- Type and number of connected PV modules
- Error code
- Mounting location
- Installation date
- Warranty card

Warranty terms and conditions can be downloaded at www.solplanet.net.

When the customer needs warranty service during the warranty period, the customer must provide a copy of the invoice, factory warranty card, and ensure the electrical label of the inverter is legible. If these conditions are not met, Solplanet has the right to refuse to provide with the relevant warranty service.

16 Contact

EMEA

Service email: service.EMEA@solplanet.net

APAC

Service email: service.APAC@solplanet.net

LATAM

Service email: service.LATAM@solplanet.net

AISWEI Pty Ltd.

Hotline: +61 390 988 674

Add.: Level 40, 140 William Street, Melbourne VIC 3000, Australia

AISWEI B.V.

Hotline: +31 208 004 844 (Netherlands)

+48 134 926 109 (Poland)

Add.: Barbara Strozilaan 101,5e etage,kantoornummer 5.12,1083HN Amsterdam,the Netherlands

AISWEI Technology Co., Ltd

Hotline: +86 400 801 9996

Add.: Room 904 - 905, No. 757 Mengzi Road, Huangpu District, Shanghai 200023

<https://solplanet.net/contact-us/>

Scan QR code:



Android

Scan QR code:



iOS

